

Control System Toolbox™

Reference



MATLAB®

R2022b



How to Contact MathWorks



Latest news: www.mathworks.com
Sales and services: www.mathworks.com/sales_and_services
User community: www.mathworks.com/matlabcentral
Technical support: www.mathworks.com/support/contact_us



Phone: 508-647-7000



The MathWorks, Inc.
1 Apple Hill Drive
Natick, MA 01760-2098

Control System Toolbox™ Reference

© COPYRIGHT 2001–2022 by The MathWorks, Inc.

The software described in this document is furnished under a license agreement. The software may be used or copied only under the terms of the license agreement. No part of this manual may be photocopied or reproduced in any form without prior written consent from The MathWorks, Inc.

FEDERAL ACQUISITION: This provision applies to all acquisitions of the Program and Documentation by, for, or through the federal government of the United States. By accepting delivery of the Program or Documentation, the government hereby agrees that this software or documentation qualifies as commercial computer software or commercial computer software documentation as such terms are used or defined in FAR 12.212, DFARS Part 227.72, and DFARS 252.227-7014. Accordingly, the terms and conditions of this Agreement and only those rights specified in this Agreement, shall pertain to and govern the use, modification, reproduction, release, performance, display, and disclosure of the Program and Documentation by the federal government (or other entity acquiring for or through the federal government) and shall supersede any conflicting contractual terms or conditions. If this License fails to meet the government's needs or is inconsistent in any respect with federal procurement law, the government agrees to return the Program and Documentation, unused, to The MathWorks, Inc.

Trademarks

MATLAB and Simulink are registered trademarks of The MathWorks, Inc. See www.mathworks.com/trademarks for a list of additional trademarks. Other product or brand names may be trademarks or registered trademarks of their respective holders.

Patents

MathWorks products are protected by one or more U.S. patents. Please see www.mathworks.com/patents for more information.

Revision History

June 2001	Online only	New for Version 5.1 (Release 12.1)
July 2002	Online only	Revised for Version 5.2 (Release 13)
June 2004	Online only	Revised for Version 6.0 (Release 14)
March 2005	Online only	Revised for Version 6.2 (Release 14SP2)
September 2005	Online only	Revised for Version 6.2.1 (Release 14SP3)
March 2006	Online only	Revised for Version 7.0 (Release 2006a)
September 2006	Online only	Revised for Version 7.1 (Release 2006b)
March 2007	Online only	Revised for Version 8.0 (Release 2007a)
September 2007	Online only	Revised for Version 8.0.1 (Release 2007b)
March 2008	Online only	Revised for Version 8.1 (Release 2008a)
October 2008	Online only	Revised for Version 8.2 (Release 2008b)
March 2009	Online only	Revised for Version 8.3 (Release 2009a)
September 2009	Online only	Revised for Version 8.4 (Release 2009b)
March 2010	Online only	Revised for Version 8.5 (Release 2010a)
September 2010	Online only	Revised for Version 9.0 (Release 2010b)
April 2011	Online only	Revised for Version 9.1 (Release 2011a)
September 2011	Online only	Revised for Version 9.2 (Release 2011b)
March 2012	Online only	Revised for Version 9.3 (Release 2012a)
September 2012	Online only	Revised for Version 9.4 (Release 2012b)
March 2013	Online only	Revised for Version 9.5 (Release 2013a)
September 2013	Online only	Revised for Version 9.6 (Release 2013b)
March 2014	Online only	Revised for Version 9.7 (Release 2014a)
October 2014	Online only	Revised for Version 9.8 (Release 2014b)
March 2015	Online only	Revised for Version 9.9 (Release 2015a)
September 2015	Online only	Revised for Version 9.10 (Release 2015b)
March 2016	Online only	Revised for Version 10.0 (Release 2016a)
September 2016	Online only	Revised for Version 10.1 (Release 2016b)
March 2017	Online only	Revised for Version 10.2 (Release 2017a)
September 2017	Online only	Revised for Version 10.3 (Release 2017b)
March 2018	Online only	Revised for Version 10.4 (Release 2018a)
September 2018	Online only	Revised for Version 10.5 (Release 2018b)
March 2019	Online only	Revised for Version 10.6 (Release 2019a)
September 2019	Online only	Revised for Version 10.7 (Release 2019b)
March 2020	Online only	Revised for Version 10.8 (Release 2020a)
September 2020	Online only	Revised for Version 10.9 (Release 2020b)
March 2021	Online only	Revised for Version 10.10 (Release 2021a)
September 2021	Online only	Revised for Version 10.11 (Release 2021b)
March 2022	Online only	Revised for Version 10.11.1 (Release 2022a)
September 2022	Online only	Revised for Version 10.12 (Release 2022b)

1 | _____ **Classes**

2 | _____ **Functions**

3 | _____ **Blocks**

Classes

TuningGoal.ConicSector class

Package: TuningGoal

Sector bound for control system tuning

Description

A conic sector bound is a restriction on the output trajectories of a system. If for all nonzero input trajectories $u(t)$, the output trajectory $z(t) = (Hu)(t)$ of a linear system H satisfies:

$$\int_0^T z(t)^T Q z(t) dt < 0,$$

for all $T \geq 0$, then the output trajectories of H lie in the conic sector described by the symmetric indefinite matrix Q . Selecting different Q matrices imposes different conditions on the system response.

When tuning a control system with `systemtune`, use `TuningGoal.ConicSector` to restrict the output trajectories of the response between specified inputs and outputs to a specified sector. For more information about sector bounds, see “About Sector Bounds and Sector Indices”.

Construction

`Req = TuningGoal.ConicSector(inputname,outputname,Q)` creates a tuning goal for restricting the response $H(s)$ from inputs `inputname` to outputs `outputname` to the conic sector specified by the symmetric matrix Q . The tuning goal constrains H such that its trajectories $z(t) = (Hu)(t)$ satisfy:

$$\int_0^T z(t)^T Q z(t) dt < 0,$$

for all $T \geq 0$. (See “About Sector Bounds and Sector Indices”.) The matrix Q must have as many negative eigenvalues as there are inputs in H .

To specify frequency-dependent sector bounds, set Q to an LTI model that satisfies $Q(s)^T = Q(-s)$.

Input Arguments

inputname

Input signals for the tuning goal, specified as a character vector or, for multiple-input tuning goals, a cell array of character vectors.

- If you are using the tuning goal to tune a Simulink® model of a control system, then `inputname` can include:
 - Any model input.
 - Any linear analysis point marked in the model.
 - Any linear analysis point in an `sITuner` interface associated with the Simulink model. Use `addPoint` to add analysis points to the `sITuner` interface. Use `getPoints` to get the list of analysis points available in an `sITuner` interface to your model.

For example, suppose that the `sLTuner` interface contains analysis points `u1` and `u2`. Use `'u1'` to designate that point as an input signal when creating tuning goals. Use `{'u1', 'u2'}` to designate a two-channel input.

- If you are using the tuning goal to tune a generalized state-space (`genss`) model of a control system, then `inputname` can include:
 - Any input of the `genss` model
 - Any `AnalysisPoint` location in the control system model

For example, if you are tuning a control system model, `T`, then `inputname` can be any input name in `T.InputName`. Also, if `T` contains an `AnalysisPoint` block with a location named `AP_u`, then `inputname` can include `'AP_u'`. Use `getPoints` to get a list of analysis points available in a `genss` model.

If `inputname` is an `AnalysisPoint` location of a generalized model, the input signal for the tuning goal is the implied input associated with the `AnalysisPoint` block:



For more information about analysis points in control system models, see “Mark Signals of Interest for Control System Analysis and Design”.

outputname

Output signals for the tuning goal, specified as a character vector or, for multiple-output tuning goals, a cell array of character vectors.

- If you are using the tuning goal to tune a Simulink model of a control system, then `outputname` can include:
 - Any model output.
 - Any linear analysis point marked in the model.
 - Any linear analysis point in an `sLTuner` interface associated with the Simulink model. Use `addPoint` to add analysis points to the `sLTuner` interface. Use `getPoints` to get the list of analysis points available in an `sLTuner` interface to your model.

For example, suppose that the `sLTuner` interface contains analysis points `y1` and `y2`. Use `'y1'` to designate that point as an output signal when creating tuning goals. Use `{'y1', 'y2'}` to designate a two-channel output.

- If you are using the tuning goal to tune a generalized state-space (`genss`) model of a control system, then `outputname` can include:
 - Any output of the `genss` model
 - Any `AnalysisPoint` location in the control system model

For example, if you are tuning a control system model, `T`, then `outputname` can be any output name in `T.OutputName`. Also, if `T` contains an `AnalysisPoint` block with a location named

AP_u, then outputname can include 'AP_u'. Use `getPoints` to get a list of analysis points available in a genss model.

If outputname is an `AnalysisPoint` location of a generalized model, the output signal for the tuning goal is the implied output associated with the `AnalysisPoint` block:



For more information about analysis points in control system models, see “Mark Signals of Interest for Control System Analysis and Design”.

Q

Sector geometry, specified as:

- A matrix, for constant sector geometry. Q is a symmetric square matrix that is n_y on a side, where n_y is the number of signals in outputname. The matrix Q must be indefinite to describe a well-defined conic sector. An indefinite matrix has both positive and negative eigenvalues. In particular, Q must have as many negative eigenvalues as there are input channels specified in inputname (the size of the vector input signal $u(t)$).
- An LTI model, for frequency-dependent sector geometry. Q satisfies $Q(s)^T = Q(-s)$. In other words, $Q(s)$ evaluates to a Hermitian matrix at each frequency.

For more information, see “About Sector Bounds and Sector Indices”.

Properties

SectorMatrix

Sector geometry, specified as a matrix or an LTI model. The Q input argument sets initial value of `SectorMatrix` when you create the tuning goal, and the same restrictions and characteristics apply to `SectorMatrix` as apply to Q .

Regularization

Regularization parameter, specified as a real nonnegative scalar value.

Given the indefinite factorization of the sector matrix,

$$Q = W_1 W_1^T - W_2 W_2^T, \quad W_1^T W_2 = 0$$

the sector bound

$$H(-j\omega)^T Q H(j\omega) < 0$$

is equivalent to

$$H_1(j\omega)^H H_1(j\omega) < H_2(j\omega)^H H_2(j\omega),$$

where $H_1 = W_1^T H$, $H_2 = W_2^T H$, and $(\bullet)^H$ denotes the Hermitian transpose. Enforcing this condition might become numerically challenging when other tuning goals drive both $H_1(j\omega)$ and $H_2(j\omega)$ to zero at some frequencies. This condition is equivalent to controlling the sign of a 0/0 expression, which is intractable in the presence of rounding errors. To avoid this condition, you can regularize the sector bound to

$$H(-j\omega)^T Q H(j\omega) < -\varepsilon^2 I,$$

or equivalently,

$$H_1(j\omega)^H H_1(j\omega) + \varepsilon^2 I < H_2(j\omega)^H H_2(j\omega).$$

This regularization prevents $H_2(j\omega)$ from becoming singular, and helps keep evaluation of the tuning goal numerically tractable. Use the **Regularization** property to set the value of ε to a small (but not negligible) fraction of the typical norm of the feedthrough term in H . For example, if you anticipate the norm of the feedthrough term of H to be of order 1 during tuning, try:

```
Req.Regularization = 1e-3;
```

Default: 0

Focus

Frequency band in which tuning goal is enforced, specified as a row vector of the form `[min,max]`.

Set the **Focus** property to limit enforcement of the tuning goal to a particular frequency band. Express this value in the frequency units of the control system model you are tuning (rad/TimeUnit). For example, suppose **Req** is a tuning goal that you want to apply only between 1 and 100 rad/s. To restrict the tuning goal to this band, use the following command:

```
Req.Focus = [1,100];
```

Default: `[0,Inf]` for continuous time; `[0,pi/Ts]` for discrete time, where T_s is the model sample time.

Input

Input signal names, specified as a cell array of character vectors. The input signal names specify the inputs of the constrained response, initially populated by the `inputname` argument.

Output

Output signal names, specified as a cell array of character vectors. The output signal names specify the outputs of the constrained response, initially populated by the `outputname` argument.

Models

Models to which the tuning goal applies, specified as a vector of indices.

Use the **Models** property when tuning an array of control system models with `systemtune`, to enforce a tuning goal for a subset of models in the array. For example, suppose you want to apply the tuning goal, **Req**, to the second, third, and fourth models in a model array passed to `systemtune`. To restrict enforcement of the tuning goal, use the following command:

```
Req.Models = 2:4;
```

When `Models = NaN`, the tuning goal applies to all models.

Default: NaN

Openings

Feedback loops to open when evaluating the tuning goal, specified as a cell array of character vectors that identify loop-opening locations. The tuning goal is evaluated against the open-loop configuration created by opening feedback loops at the locations you identify.

If you are using the tuning goal to tune a Simulink model of a control system, then `Openings` can include any linear analysis point marked in the model, or any linear analysis point in an `sLTuner` interface associated with the Simulink model. Use `addPoint` to add analysis points and loop openings to the `sLTuner` interface. Use `getPoints` to get the list of analysis points available in an `sLTuner` interface to your model.

If you are using the tuning goal to tune a generalized state-space (`genss`) model of a control system, then `Openings` can include any `AnalysisPoint` location in the control system model. Use `getPoints` to get the list of analysis points available in the `genss` model.

For example, if `Openings = {'u1', 'u2'}`, then the tuning goal is evaluated with loops open at analysis points `u1` and `u2`.

Default: {}

Name

Name of the tuning goal, specified as a character vector.

For example, if `Req` is a tuning goal:

```
Req.Name = 'LoopReq';
```

Default: []

Examples

Conic Sector Goal

Create a tuning goal that restricts the response from an input or analysis point `'u'` to an output or analysis point `'y'` in a control system to the following sector:

$$S = \{(y, u): 0.1u^2 < uy < 10u^2\}.$$

The Q matrix for this sector is given by:

```
a = 0.1;  
b = 10;  
Q = [1 -(a+b)/2 ; -(a+b)/2 a*b];
```

Use this Q matrix to create the tuning goal.

```
TG = TuningGoal.ConicSector('u', 'y', Q)
```



```
TG =
ConicSector with properties:

    SectorMatrix: [2x2 double]
  Regularization: 0
        Focus: [0 Inf]
        Input: {'u'}
        Output: {'y'}
        Models: NaN
  Openings: {0x1 cell}
        Name: ''
```

Set properties to further configure the tuning goal. For example, suppose the control system model has an analysis point called 'OuterLoop', and you want to enforce the tuning goal with the loop open at that point.

```
TG.Openings = 'OuterLoop';
```

Before or after tuning, use `viewGoal` to visualize the tuning goal.

```
viewGoal(TG)
```

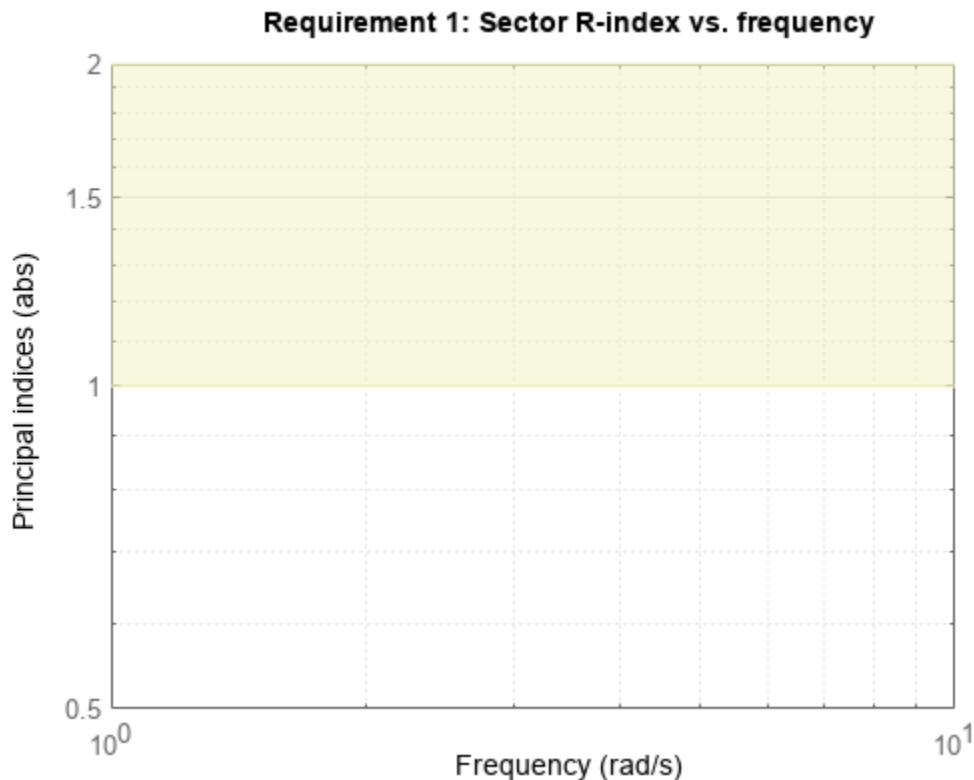

The goal is met when the relative sector index $R < 1$ at all frequencies. The shaded area represents the region where the goal is not met. When you use this requirement to tune a control system CL, `viewGoal(TG, CL)` shows R for the specified inputs and outputs on this plot, enabling you to identify frequency ranges in which the goal is not met, and by how much.

Constrain Input and Output Trajectories to Conic Sector

Consider the following control system.

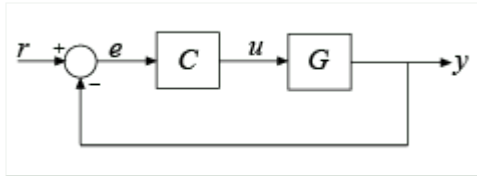

Suppose that the signal u is marked as an analysis point in a Simulink model or genss model of the control system. Suppose also that G is the closed-loop transfer function from u to y . Create a tuning goal that constrains all I/O trajectories $\{u(t), y(t)\}$ of G to satisfy:

$$\int_0^T \begin{pmatrix} y(t) \\ u(t) \end{pmatrix}^T Q \begin{pmatrix} y(t) \\ u(t) \end{pmatrix} dt < 0,$$

for all $T \geq 0$. For this example, use sector matrix that imposes input passivity with index 0.5.

```
nu = 0.5;
Q = [0 -1; -1 2*nu];
```

Constraining the I/O trajectories of G is equivalent to restricting the output trajectories $z(t)$ of $H = [G; I]$ to the sector defined by:

$$\int_0^T z(t)^T Q z(t) dt < 0.$$

(See “About Sector Bounds and Sector Indices” for more details about this equivalence.) To specify this constraint, create a tuning goal that constrains the transfer function $H = [G; I]$, which the transfer function from input u to outputs $\{y; u\}$.

```
TG = TuningGoal.ConicSector('u', {'y'; 'u'}, Q);
```

When you specify the same signal 'u' as both input and output, the conic sector tuning goal sets the corresponding transfer function to the identity. Therefore, the transfer function constrained by TG is $H = [G; I]$ as intended. This treatment is specific to the conic sector tuning goal. For other tuning goals, when the same signal appears in both inputs and outputs, the resulting transfer function is zero in the absence of feedback loops, or the complementary sensitivity at that location otherwise. This result occurs because when the software processes analysis points, it assumes the input is injected after the output. See “Mark Signals of Interest for Control System Analysis and Design” for more information about how analysis points work.

Tips

- The conic sector tuning goal requires that $W_2^T H(s)$ be square and minimum phase, where $H(s)$ is the transfer function between the specified inputs and outputs, and W_2 spans the negative invariant subspace of the sector matrix, Q :

$$Q = W_1 W_1^T - W_2 W_2^T, \quad W_1^T W_2 = 0$$

(See “Algorithms” on page 1-9.) This means that the stabilized dynamics for this goal are not the poles of H , but rather the transmission zeros of $W_2^T H(s)$. The `MinDecay` and `MaxRadius` options of `systemOptions` control the bounds on these implicitly constrained dynamics. If the optimization fails to meet the default bounds, or if the default bounds conflict with other requirements, use `systemOptions` to change these defaults.

Algorithms

Let

$$Q = W_1 W_1^T - W_2 W_2^T, \quad W_1^T W_2 = 0$$

be an indefinite factorization of Q . When $W_2^T H(s)$ is square and minimum phase, then the time-domain sector bound on trajectories $z(t) = Hu(t)$,

$$\int_0^T z(t)^T Q z(t) dt < 0,$$

is equivalent to the frequency-domain sector condition,

$$H(-j\omega)^T Q H(j\omega) < 0$$

for all frequencies. The `TuningGoal.ConicSector` goal uses this equivalence to convert the time-domain characterization into a frequency-domain condition that `system` can handle in the same way it handles gain constraints. To secure this equivalence, `TuningGoal.ConicSector` also makes $W_2^T H(s)$ minimum phase by making all its zeros stable.

For sector bounds, the R -index plays the same role as the peak gain does for gain constraints (see “About Sector Bounds and Sector Indices”). The condition

$$H(-j\omega)^T Q H(j\omega) < 0$$

is satisfied at all frequencies if and only if the R -index is less than one. The `viewGoal` plot for `TuningGoal.ConicSector` shows the R -index value as a function of frequency (see `sectorplot`).

When you tune a control system using a `TuningGoal` object to specify a tuning goal, the software converts the tuning goal into a normalized scalar value $f(x)$, where x is the vector of free (tunable) parameters in the control system. The software then adjusts the parameter values to minimize $f(x)$ or to drive $f(x)$ below 1 if the tuning goal is a hard constraint.

For the sector bound

$$H(-j\omega)^T Q H(j\omega) < 0$$

`TuningGoal.ConicSector` uses the objective function given by:

$$f(x) = \frac{R}{1 + R/R_{\max}}, \quad R_{\max} = 10^6.$$

R is the sector-bound R -index (see `getSectorIndex` for details).

The dynamics of H affected by the minimum-phase condition are the stabilized dynamics for this tuning goal. The `MinDecay` and `MaxRadius` options of `systemOptions` control the bounds on

these implicitly constrained dynamics. If the optimization fails to meet the default bounds, or if the default bounds conflict with other requirements, use `sysTuneOptions` to change these defaults.

Version History

Introduced in R2016b

See Also

`sysTune` | `sysTune (for sLTuner)` | `getSectorIndex` | `viewGoal` | `evalGoal` | `sLTuner`

Topics

“About Sector Bounds and Sector Indices”

“Tune Control Systems with SYSTUNE”

“Tune Control Systems in Simulink”

TuningGoal.ControllerPoles class

Package: TuningGoal

Constraint on controller dynamics for control system tuning

Description

Use `TuningGoal.ControllerPoles` to constrain the dynamics of a tunable component in a control system model. Use this tuning goal for constraining the dynamics of tuned blocks identified in a `sITuner` interface to a Simulink model. If you are tuning a `genss` model of a control system, use it to constrain tunable elements such as `tunableTF` or `tunableSS`. The `TuningGoal.ControllerPoles` requirement lets you control the minimum decay rate, minimum damping, and maximum natural frequency of the poles of the tunable element, ensuring that the controller is free of fast or resonant dynamics. The tuning goal can also ensure stability of the tuned value of the tunable element.

After you create a requirement object, you can further configure the tuning goal by setting "Properties" on page 1-12 of the object.

Construction

`Req = TuningGoal.ControllerPoles(blockID,mindecay,mindamping,maxfreq)` creates a tuning goal that constrains the dynamics of a tunable component of a control system. The minimum decay rate, minimum damping constant, and maximum natural frequency define a region of the complex plane in which poles of the component must lie. A nonnegative minimum decay ensures stability of the tuned poles. The tuning goal applies to all poles in the block except fixed integrators, such as the *I* term of a PID controller.

Input Arguments

blockID

Tunable component to constrain, specified as a character vector. `blockID` designates one of the tuned blocks in the control system you are tuning.

- For tuning a Simulink model of a control system, `blockID` is a tuned block in the `sITuner` interface to the model. For example, suppose the `sITuner` interface has a tuned block called `Controller`. To constrain this block, use `'Controller'` for the `blockID` input argument.
- For tuning a `genss` model of a control system, `blockid` is one of the control design blocks of that model. For example, suppose the `genss` interface has a tunable block with name `C1`. To constrain this block, use `'C1'` for the `blockID` input argument.

mindecay

Minimum decay rate of poles of tunable component, specified as a scalar value in the frequency units of the control system model you are tuning.

Specify `mindecay` ≥ 0 to ensure that the block is stable. If you specify a negative value, the tuned block can include unstable poles.

When you tune the control system using this tuning goal, all poles of the tunable component are constrained to satisfy:

- $\text{Re}(s) < -\text{mindecay}$, for continuous-time systems.
- $\log(|z|) < -\text{mindecay} \cdot T_s$, for discrete-time systems with sample time T_s .

Default: 0

mindamping

Desired minimum damping ratio of poles of the tunable block, specified as a value between 0 and 1.

Poles of the block that depend on the tunable parameters are constrained to satisfy $\text{Re}(s) < -\text{mindamping} \cdot |s|$. In discrete time, the damping ratio is computed using $s = \log(z) / T_s$.

Default: 0

maxfreq

Desired maximum natural frequency of poles of the tunable block, specified as a scalar value in the units of the control system model you are tuning.

Poles of the block are constrained to satisfy $|s| < \text{maxfreq}$ for continuous-time blocks, or $|\log(z)| < \text{maxfreq} \cdot T_s$ for discrete-time blocks with sample time T_s . This constraint prevents fast dynamics in the tunable block.

Default: Inf

Properties

Block

Name of tunable component to constrain, specified as a character vector. The `blockID` input argument sets the value of `Block`.

MinDecay

Minimum decay rate of poles of tunable component, specified as a scalar value in the frequency units of the control system you are tuning. The initial value of this property is set by the `mindecay` input argument.

$\text{MinDecay} \geq 0$ to ensure that the block is stable. If you specify a negative value, the tuned block can include unstable poles.

When you tune the control system using this tuning goal, all poles of the tunable component are constrained to satisfy $\text{Re}(s) < -\text{MinDecay}$ for continuous-time systems, or $\log(|z|) < -\text{MinDecay} \cdot T_s$ for discrete-time systems with sample time T_s .

You can use dot notation to change the value of this property after you create the tuning goal. For example, suppose `Req` is a `TuningGoal.ControllerPoles` tuning goal. Change the minimum decay rate to 0.001:

```
Req.MinDecay = 0.001;
```

Default: 0

MinDamping

Desired minimum damping ratio of poles of the tunable block, specified as a value between 0 and 1. The initial value of this property is set by the `mindamping` input argument.

Poles of the block that depend on the tunable parameters are constrained to satisfy $\text{Re}(s) < -\text{MinDamping} * |s|$. In discrete time, the damping ratio is computed using $s = \log(z)/T_s$.

Default: 0

MaxFrequency

Desired maximum natural frequency of poles of the tunable block, specified as a scalar value in the frequency units of the control system model you are tuning. The initial value of this property is set by the `maxfreq` input argument.

Poles of the block are constrained to satisfy $|s| < \text{maxfreq}$ for continuous-time blocks, or $|\log(z)| < \text{maxfreq} * T_s$ for discrete-time blocks with sample time T_s . This constraint prevents fast dynamics in the tunable block.

You can use dot notation to change the value of this property after you create the tuning goal. For example, suppose `Req` is a `TuningGoal.ControllerPoles` tuning goal. Change the maximum frequency to 1000:

```
Req.MaxFrequency = 1000;
```

Default: Inf

Name

Name of the tuning goal, specified as a character vector.

For example, if `Req` is a tuning goal:

```
Req.Name = 'LoopReq';
```

Default: []

Examples**Constrain Dynamics of Tunable Transfer Function**

Create a tuning goal that constrains the dynamics of a tunable transfer function block in a tuned control system.

For this example, suppose that you are tuning a control system that includes a compensator block parametrized as a second-order transfer function. Create a tuning goal that restricts the poles of that transfer function to the region $\text{Re}(s) < -0.1$, $|s| < 30$.

Create a tunable component that represents the compensator.

```
C = tunableTF('Compensator',2,2);
```

This command creates a Control Design Block named 'Compensator' with two poles and two zeroes. You can construct a tunable control system model, `T`, by interconnecting this Control Design

Block with other tunable and numeric LTI models. If you tune T using `systemtune`, the values of these poles and zeroes are unconstrained by default.

Create a tuning requirement to constrain the dynamics of the compensator block. Set the minimum decay rate to 0.1 rad/s, and set the maximum frequency to 30 rad/s.

```
Req = TuningGoal.ControllerPoles('Compensator',0.1,0,30);
```

The `mindamping` input argument is 0, which imposes no constraint on the damping constant of the poles of the block.

If you tune T using `systemtune` and the tuning requirement `Req`, the poles of the compensator block are constrained satisfy these values. After you tune T, you can use `viewGoal` to validate the tuned control system against the tuning goal.

Tips

- `TuningGoal.ControllerPoles` restricts the dynamics of a single tunable component of the control system. To ensure the stability or restrict the overall dynamics of the tuned control system, use `TuningGoal.Poles`.

Algorithms

When you use a `TuningGoal` object to specify a tuning goal, the software converts the tuning goal into a normalized scalar value $f(x)$. x is the vector of free (tunable) parameters in the control system. The software then adjusts the parameter values to minimize $f(x)$, or to drive $f(x)$ below 1 if the tuning goal is a hard constraint.

For `TuningGoal.ControllerPoles`, $f(x)$ reflects the relative satisfaction or violation of the goal. For example, if you attempt to constrain the pole of a tuned block to a minimum damping of $\zeta = 0.5$, then:

- $f(x) = 1$ means the damping of the pole is $\zeta = 0.5$ exactly.
- $f(x) = 1.1$ means the damping is $\zeta = 0.5/1.1 = 0.45$, roughly 10% less than the target.
- $f(x) = 0.9$ means the damping is $\zeta = 0.5/0.9 = 0.55$, roughly 10% better than the target.

Version History

Introduced in R2016a

Functionality moved from Robust Control Toolbox

Behavior changed in R2016a

Prior to R2016a, this functionality required a Robust Control Toolbox™ license.

See Also

`looptune` | `systemtune` | `systemtune` (for `sITuner`) | `looptune` (for `sITuner`) | `viewGoal` | `evalGoal` | `tunableTF` | `tunableSS` | `TuningGoal.Poles`

Topics

“System Dynamics Specifications”

“Models with Tunable Coefficients”

TuningGoal.Gain class

Package: TuningGoal

Gain constraint for control system tuning

Description

Use the `TuningGoal.Gain` object to specify a constraint that limits the gain from a specified input to a specified output. Use this tuning goal for control system tuning with tuning commands such as `systemtune` or `looptune`.

When you use `TuningGoal.Gain`, the software attempts to tune the system so that the gain from the specified input to the specified output does not exceed the specified value. By default, the constraint is applied with the loop closed. To apply the constraint to an open-loop response, use the `Openings` property of the `TuningGoal.Gain` object.

You can use a gain constraint to:

- Enforce a design requirement of disturbance rejection across a particular input/output pair, by constraining the gain to be less than 1
- Enforce a custom roll-off rate in a particular frequency band, by specifying a gain profile in that band

Construction

`Req = TuningGoal.Gain(inputname,outputname,gainvalue)` creates a tuning goal that constrains the gain from `inputname` to `outputname` to remain below the value `gainvalue`.

You can specify the `inputname` or `outputname` as cell arrays (vector-valued signals). If you do so, then the tuning goal constrains the largest singular value of the transfer matrix from `inputname` to `outputname`. See `sigma` for more information about singular values.

`Req = TuningGoal.Gain(inputname,outputname,gainprofile)` specifies the maximum gain as a function of frequency. You can specify the target gain profile (maximum gain across the I/O pair) as a smooth transfer function. Alternatively, you can sketch a piecewise error profile using an `frd` model.

Input Arguments

inputname

Input signals for the tuning goal, specified as a character vector or, for multiple-input tuning goals, a cell array of character vectors.

- If you are using the tuning goal to tune a Simulink model of a control system, then `inputname` can include:
 - Any model input.
 - Any linear analysis point marked in the model.

- Any linear analysis point in an `sLTuner` interface associated with the Simulink model. Use `addPoint` to add analysis points to the `sLTuner` interface. Use `getPoints` to get the list of analysis points available in an `sLTuner` interface to your model.

For example, suppose that the `sLTuner` interface contains analysis points `u1` and `u2`. Use `'u1'` to designate that point as an input signal when creating tuning goals. Use `{'u1', 'u2'}` to designate a two-channel input.

- If you are using the tuning goal to tune a generalized state-space (`genss`) model of a control system, then `inputname` can include:
 - Any input of the `genss` model
 - Any `AnalysisPoint` location in the control system model

For example, if you are tuning a control system model, `T`, then `inputname` can be any input name in `T.InputName`. Also, if `T` contains an `AnalysisPoint` block with a location named `AP_u`, then `inputname` can include `'AP_u'`. Use `getPoints` to get a list of analysis points available in a `genss` model.

If `inputname` is an `AnalysisPoint` location of a generalized model, the input signal for the tuning goal is the implied input associated with the `AnalysisPoint` block:



For more information about analysis points in control system models, see “Mark Signals of Interest for Control System Analysis and Design”.

outputname

Output signals for the tuning goal, specified as a character vector or, for multiple-output tuning goals, a cell array of character vectors.

- If you are using the tuning goal to tune a Simulink model of a control system, then `outputname` can include:
 - Any model output.
 - Any linear analysis point marked in the model.
 - Any linear analysis point in an `sLTuner` interface associated with the Simulink model. Use `addPoint` to add analysis points to the `sLTuner` interface. Use `getPoints` to get the list of analysis points available in an `sLTuner` interface to your model.

For example, suppose that the `sLTuner` interface contains analysis points `y1` and `y2`. Use `'y1'` to designate that point as an output signal when creating tuning goals. Use `{'y1', 'y2'}` to designate a two-channel output.

- If you are using the tuning goal to tune a generalized state-space (`genss`) model of a control system, then `outputname` can include:
 - Any output of the `genss` model

- Any `AnalysisPoint` location in the control system model

For example, if you are tuning a control system model, `T`, then `outputname` can be any output name in `T.OutputName`. Also, if `T` contains an `AnalysisPoint` block with a location named `AP_u`, then `outputname` can include `'AP_u'`. Use `getPoints` to get a list of analysis points available in a `genss` model.

If `outputname` is an `AnalysisPoint` location of a generalized model, the output signal for the tuning goal is the implied output associated with the `AnalysisPoint` block:



For more information about analysis points in control system models, see “Mark Signals of Interest for Control System Analysis and Design”.

gainvalue

Maximum gain (linear). The gain constraint `Req` specifies that the gain from `inputname` to `outputname` is less than `gainvalue`.

`gainvalue` is a scalar value. If the signals `inputname` or `outputname` are vector-valued signals, then `gainvalue` constrains the largest singular value of the transfer matrix from `inputname` to `outputname`. See `sigma` for more information about singular values.

gainprofile

Gain profile as a function of frequency. The gain constraint `Req` specifies that the gain from `inputname` to `outputname` at a particular frequency is less than `gainprofile`. You can specify `gainprofile` as a smooth transfer function (`tf`, `zpk`, or `ss` model). Alternatively, you can sketch a piecewise gain profile using a `frd` model or the `makeweight` function. When you do so, the software automatically maps the gain profile onto a `zpk` model. The magnitude of this `zpk` model approximates the desired gain profile. Use `viewGoal(Req)` to plot the magnitude of the `zpk` model.

`gainprofile` is a SISO transfer function. If `inputname` or `outputname` are cell arrays, `gainprofile` applies to all I/O pairs from `inputname` to `outputname`

If you are tuning in discrete time (that is, using a `genss` model or `sITuner` interface with nonzero `Ts`), you can specify `gainprofile` as a discrete-time model with the same `Ts`. If you specify `gainprofile` in continuous time, the tuning software discretizes it. Specifying the gain profile in discrete time gives you more control over the gain profile near the Nyquist frequency.

Properties

MaxGain

Maximum gain as a function of frequency, expressed as a SISO `zpk` model.

The software automatically maps the `gainvalue` or `gainprofile` input arguments to a `zpk` model. The magnitude of this `zpk` model approximates the desired gain profile. The tuning goal derives and is stored in the `MaxGain` property. Use `viewGoal(Req)` to plot the magnitude of `MaxGain`.

Focus

Frequency band in which tuning goal is enforced, specified as a row vector of the form `[min,max]`.

Set the `Focus` property to limit enforcement of the tuning goal to a particular frequency band. Express this value in the frequency units of the control system model you are tuning (`rad/TimeUnit`). For example, suppose `Req` is a tuning goal that you want to apply only between 1 and 100 rad/s. To restrict the tuning goal to this band, use the following command:

```
Req.Focus = [1,100];
```

Default: `[0,Inf]` for continuous time; `[0,pi/Ts]` for discrete time, where `Ts` is the model sample time.

Stabilize

Stability requirement on closed-loop dynamics, specified as 1 (`true`) or 0 (`false`).

By default, `TuningGoal.Gain` imposes a stability requirement on the closed-loop transfer function from the specified inputs to outputs, in addition to the gain requirement. If stability is not required or cannot be achieved, set `Stabilize` to `false` to remove the stability requirement. For example, if the gain constraint applies to an unstable open-loop transfer function, set `Stabilize` to `false`.

Default: 1(`true`)

InputScaling

Input signal scaling, specified as a vector of positive real values.

Use this property to specify the relative amplitude of each entry in vector-valued input signals when the choice of units results in a mix of small and large signals. This information is used to scale the closed-loop transfer function from `Input` to `Output` when the tuning goal is evaluated.

Suppose $T(s)$ is the closed-loop transfer function from `Input` to `Output`. The tuning goal is evaluated for the scaled transfer function $D_o^{-1}T(s)D_i$. The diagonal matrices D_o and D_i have the `OutputScaling` and `InputScaling` values on the diagonal, respectively.

The default value, `[]`, means no scaling.

Default: `[]`

OutputScaling

Output signal scaling, specified as a vector of positive real values.

Use this property to specify the relative amplitude of each entry in vector-valued output signals when the choice of units results in a mix of small and large signals. This information is used to scale the closed-loop transfer function from `Input` to `Output` when the tuning goal is evaluated.

Suppose $T(s)$ is the closed-loop transfer function from `Input` to `Output`. The tuning goal is evaluated for the scaled transfer function $D_o^{-1}T(s)D_i$. The diagonal matrices D_o and D_i have the `OutputScaling` and `InputScaling` values on the diagonal, respectively.

The default value, `[]`, means no scaling.

Default: `[]`

Input

Input signal names, specified as a cell array of character vectors that identify the inputs of the transfer function that the tuning goal constrains. The initial value of the `Input` property is set by the `inputname` input argument when you construct the tuning goal.

Output

Output signal names, specified as a cell array of character vectors that identify the outputs of the transfer function that the tuning goal constrains. The initial value of the `Output` property is set by the `outputname` input argument when you construct the tuning goal.

Models

Models to which the tuning goal applies, specified as a vector of indices.

Use the `Models` property when tuning an array of control system models with `systemtune`, to enforce a tuning goal for a subset of models in the array. For example, suppose you want to apply the tuning goal, `Req`, to the second, third, and fourth models in a model array passed to `systemtune`. To restrict enforcement of the tuning goal, use the following command:

```
Req.Models = 2:4;
```

When `Models = NaN`, the tuning goal applies to all models.

Default: `NaN`

Openings

Feedback loops to open when evaluating the tuning goal, specified as a cell array of character vectors that identify loop-opening locations. The tuning goal is evaluated against the open-loop configuration created by opening feedback loops at the locations you identify.

If you are using the tuning goal to tune a Simulink model of a control system, then `Openings` can include any linear analysis point marked in the model, or any linear analysis point in an `sLTuner` interface associated with the Simulink model. Use `addPoint` to add analysis points and loop openings to the `sLTuner` interface. Use `getPoints` to get the list of analysis points available in an `sLTuner` interface to your model.

If you are using the tuning goal to tune a generalized state-space (`genss`) model of a control system, then `Openings` can include any `AnalysisPoint` location in the control system model. Use `getPoints` to get the list of analysis points available in the `genss` model.

For example, if `Openings = {'u1', 'u2'}`, then the tuning goal is evaluated with loops open at analysis points `u1` and `u2`.

Default: `{}`

Name

Name of the tuning goal, specified as a character vector.

For example, if `Req` is a tuning goal:

```
Req.Name = 'LoopReq';
```

Default: []

Examples

Disturbance Rejection Goal

Create a gain constraint that enforces a disturbance rejection requirement from a signal 'du' to a signal 'u'.

```
Req = TuningGoal.Gain('du','u',1);
```

This requirement specifies that the maximum gain of the response from 'du' to 'u' not exceed 1 (0 dB).

Custom roll-off specification

Create a tuning goal that constrains the response from a signal 'du' to a signal 'u' to roll off at 20 dB/decade at frequencies greater than 1. The tuning goal also specifies disturbance rejection (maximum gain of 1) in the frequency range [0,1].

```
gmax = frd([1 1 0.01],[0 1 100]);  
Req = TuningGoal.Gain('du','u',gmax);
```

These commands use a `frd` model to specify the gain profile as a function of frequency. The maximum gain of 1 dB at the frequency 1 rad/s, together with the maximum gain of 0.01 dB at the frequency 100 rad/s, specifies the desired rolloff of 20 dB/decade.

The software converts `gmax` into a smooth function of frequency that approximates the piecewise specified requirement. Display the gain profile using `viewGoal`.

```
viewGoal(Req)
```

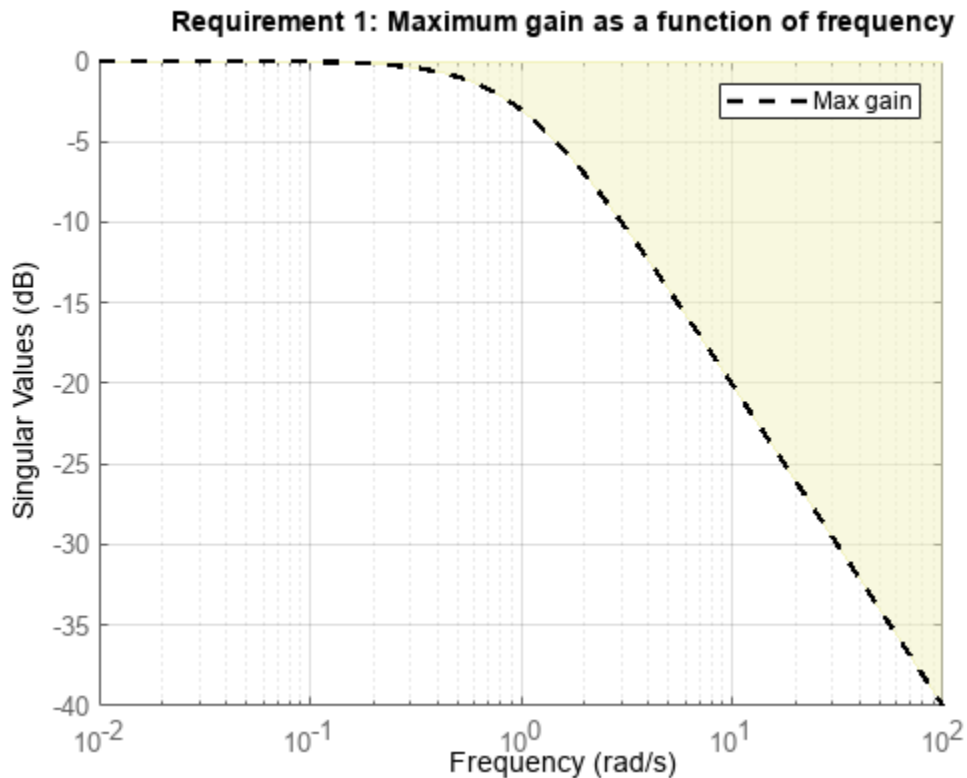

The dashed line shows the gain profile, and the region indicates where the requirement is violated.

Tips

- This tuning goal imposes an implicit stability constraint on the closed-loop transfer function from Input to Output, evaluated with loops opened at the points identified in Openings. The dynamics affected by this implicit constraint are the stabilized dynamics for this tuning goal. The MinDecay and MaxRadius options of `systemOptions` control the bounds on these implicitly constrained dynamics. If the optimization fails to meet the default bounds, or if the default bounds conflict with other requirements, use `systemOptions` to change these defaults.

Algorithms

When you tune a control system using a `TuningGoal` object, the software converts the tuning goal into a normalized scalar value $f(x)$, where x is the vector of free (tunable) parameters in the control system. The software then adjusts the parameter values to minimize $f(x)$ or to drive $f(x)$ below 1 if the tuning goal is a hard constraint.

For `TuningGoal.Gain`, $f(x)$ is given by:

$$f(x) = \|W_F(s)D_o^{-1}T(s,x)D_i\|_{\infty},$$

or its discrete-time equivalent, for discrete-time tuning. Here, $T(s,x)$ is the closed-loop transfer function from Input to Output. D_o and D_i are diagonal matrices with the `OutputScaling` and

InputScaling property values on the diagonal, respectively. $\| \cdot \|_{\infty}$ denotes the H_{∞} norm (see `getPeakGain`).

The frequency weighting function W_F is the regularized gain profile, derived from the maximum gain profile you specify. The gains of W_F and `1/MaxGain` roughly match inside the frequency band `Focus`. W_F is always stable and proper. Because poles of W_F close to $s = 0$ or $s = \text{Inf}$ might lead to poor numeric conditioning of the `system` optimization problem, it is not recommended to specify maximum gain profiles with very low-frequency or very high-frequency dynamics.

To obtain W_F , use:

```
WF = getWeight(Req,Ts)
```

where `Req` is the tuning goal, and `Ts` is the sample time at which you are tuning (`Ts = 0` for continuous time). For more information about regularization and its effects, see “Visualize Tuning Goals”.

Version History

Introduced in R2016a

Functionality moved from Robust Control Toolbox

Behavior changed in R2016a

Prior to R2016a, this functionality required a Robust Control Toolbox license.

See Also

`looptune` | `viewGoal` | `system` | `system` (for `sITuner`) | `looptune` (for `sITuner`) | `TuningGoal.Tracking` | `TuningGoal.LoopShape` | `sITuner` | `makeweight`

Topics

“Frequency-Domain Specifications”

“Visualize Tuning Goals”

“Control of a Linear Electric Actuator”

“MIMO Control of Diesel Engine”

TuningGoal.LoopShape class

Package: TuningGoal

Target loop shape for control system tuning

Description

Use `TuningGoal.LoopShape` to specify a target gain profile (gain as a function of frequency) of an open-loop response. `TuningGoal.LoopShape` constrains the open-loop, point-to-point response (L) at a specified location in your control system. Use this tuning goal for control system tuning with tuning commands, such as `systune` or `looptune`.

When you tune a control system, the target open-loop gain profile is converted into constraints on the inverse sensitivity function $\text{inv}(S) = (I + L)$ and the complementary sensitivity function $T = 1 - S$. These constraints are illustrated for a representative tuned system in the following figure.

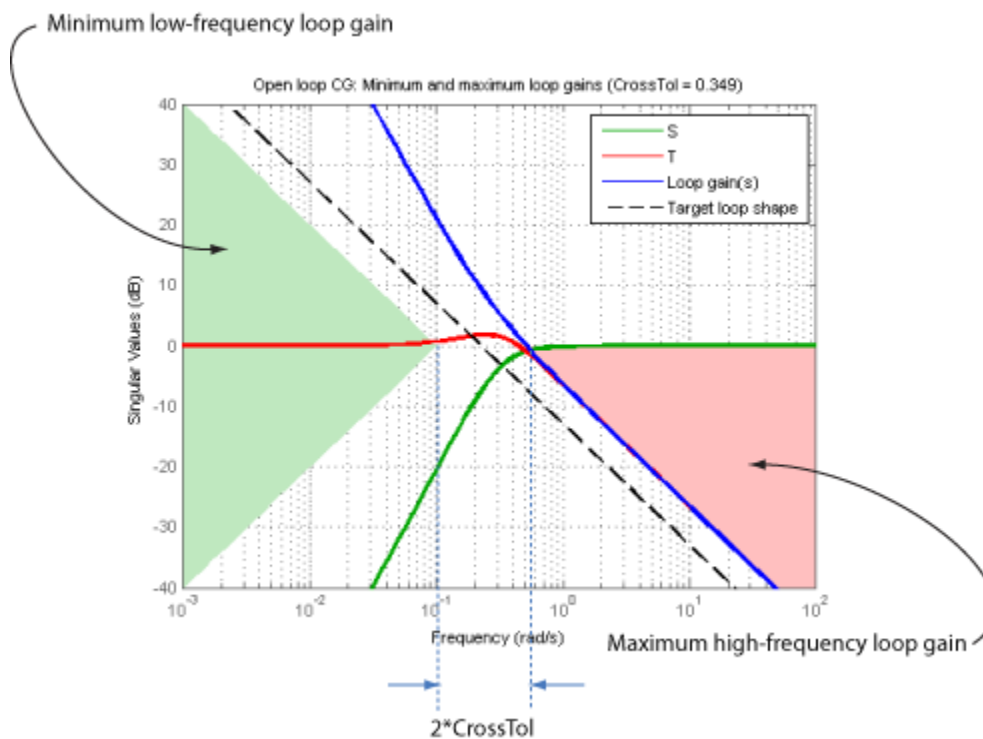

Where L is much greater than 1, a minimum gain constraint on $\text{inv}(S)$ (green shaded region) is equivalent to a minimum gain constraint on L . Similarly, where L is much smaller than 1, a maximum gain constraint on T (red shaded region) is equivalent to a maximum gain constraint on L . The gap between these two constraints is twice the `CrossTol` parameter, which specifies the frequency band where the loop gain can cross 0 dB.

For multi-input, multi-output (MIMO) control systems, values in the gain profile greater than 1 are interpreted as minimum performance requirements. Such values are lower bounds on the smallest singular value of the open-loop response. Gain profile values less than one are interpreted as

minimum roll-off requirements, which are upper bounds on the largest singular value of the open-loop response. For more information about singular values, see `sigma`.

Use `TuningGoal.LoopShape` when the loop shape near crossover is simple or well understood (such as integral action). To specify only high gain or low gain constraints in certain frequency bands, use `TuningGoal.MinLoopGain` and `TuningGoal.MaxLoopGain`. When you do so, the software determines the best loop shape near crossover.

Construction

`Req = TuningGoal.LoopShape(location, loopgain)` creates a tuning goal for shaping the open-loop response measured at the specified location. The magnitude of the single-input, single-output (SISO) transfer function `loopgain` specifies the target open-loop gain profile. You can specify the target gain profile (maximum gain across the I/O pair) as a smooth transfer function or sketch a piecewise error profile using an `frd` model.

`Req = TuningGoal.LoopShape(location, loopgain, crosstol)` specifies a tolerance on the location of the crossover frequency. `crosstol` expresses the tolerance in decades. For example, `crosstol = 0.5` allows gain crossovers within half a decade on either side of the target crossover frequency specified by `loopgain`. When you omit `crosstol`, the tuning goal uses a default value of 0.1 decades. You can increase `crosstol` when tuning MIMO control systems. Doing so allows more widely varying crossover frequencies for different loops in the system.

`Req = TuningGoal.LoopShape(location, wc)` specifies just the target gain crossover frequency. This syntax is equivalent to specifying a pure integrator loop shape, `loopgain = wc/s`.

`Req = TuningGoal.LoopShape(location, wcrange)` specifies a range for the target gain crossover frequency. The range is a vector of the form `wcrange = [wc1, wc2]`. This syntax is equivalent to using the geometric mean `sqrt(wc1*wc2)` as `wc` and setting `crosstol` to the half-width of `wcrange` in decades. Using a range instead of a single `wc` value increases the ability of the tuning algorithm to enforce the target loop shape for all loops in a MIMO control system.

Input Arguments

location

Location where the open-loop response shape to be constrained is measured, specified as a character vector or cell array of character vectors that identify one or more locations in the control system to tune. What locations are available depends on what kind of system you are tuning:

- If you are tuning a Simulink model of a control system, you can use any linear analysis point marked in the model, or any linear analysis point in an `sLTuner` interface associated with the Simulink model. Use `addPoint` to add analysis points to the `sLTuner` interface. For example, if the `sLTuner` interface contains an analysis point `u`, you can use `'u'` to refer to that point when creating tuning goals. Use `getPoints` to get the list of analysis points available in an `sLTuner` interface to your model.
- If you are tuning a generalized state-space (`genss`) model of a control system, you can use any `AnalysisPoint` location in the control system model. For example, the following code creates a PI loop with an analysis point at the plant input `'u'`.

```
AP = AnalysisPoint('u');
G = tf(1, [1 2]);
C = tunablePID('C', 'pi');
T = feedback(G*AP*C, 1);
```

When creating tuning goals, you can use 'u' to refer to the analysis point at the plant input. Use `getPoints` to get the list of analysis points available in a `genss` model.

The loop shape requirement applies to the point-to-point open-loop transfer function at the specified location. That transfer function is the open-loop response obtained by injecting signals at the location and measuring the return signals at the same point.

If `location` specifies multiple locations, then the loop-shape requirement applies to the MIMO open-loop transfer function.

loopgain

Target open-loop gain profile as a function of frequency.

You can specify `loopgain` as a smooth SISO transfer function (`tf`, `zpk`, or `ss` model). Alternatively, you can sketch a piecewise gain profile using a `frd` model or the `makeweight` function. When you do so, the software automatically maps your specified gain profile to a `zpk` model whose magnitude approximates the desired gain profile. Use `viewGoal(Req)` to plot the magnitude of that `zpk` model.

For multi-input, multi-output (MIMO) control systems, values in the gain profile greater than 1 are interpreted as minimum performance requirements. These values are lower bounds on the smallest singular value of L . Gain profile values less than one are interpreted as minimum roll-off requirements, which are upper bounds on the largest singular value of L . For more information about singular values, see `sigma`.

If you are tuning in discrete time (that is, using a `genss` model or `slTuner` interface with nonzero T_s), you can specify `loopgain` as a discrete-time model with the same T_s . If you specify `loopgain` in continuous time, the tuning software discretizes it. Specifying the loop shape in discrete time gives you more control over the loop shape near the Nyquist frequency.

crosstol

Tolerance in the location of crossover frequency, in decades. specified as a scalar value. For example, `crosstol = 0.5` allows gain crossovers within half a decade on either side of the target crossover frequency specified by `loopgain`. Increasing `crosstol` increases the ability of the tuning algorithm to enforce the target loop shape for all loops in a MIMO control system.

Default: 0.1

wc

Target crossover frequency, specified as a positive scalar value. Express `wc` in units of `rad/TimeUnit`, where `TimeUnit` is the `TimeUnit` property of the control system model you are tuning.

wcrange

Range for target crossover frequency, specified as a vector of the form `[wc1,wc2]`. Express `wc` in units of `rad/TimeUnit`, where `TimeUnit` is the `TimeUnit` property of the control system model you are tuning.

Properties

LoopGain

Target loop shape as a function of frequency, specified as a SISO `zpk` model.

The software automatically maps the input argument `loopgain` onto a zpk model. The magnitude of this zpk model approximates the desired gain profile. Use `viewGoal(Req)` to plot the magnitude of the zpk model `LoopGain`.

CrossTol

Tolerance on gain crossover frequency, in decades.

The initial value of `CrossTol` is set by the `crosstol` input when you create the tuning goal.

Default: 0.1

Focus

Frequency band in which tuning goal is enforced, specified as a row vector of the form `[min,max]`.

Set the `Focus` property to limit enforcement of the tuning goal to a particular frequency band. Express this value in the frequency units of the control system model you are tuning (`rad/TimeUnit`). For example, suppose `Req` is a tuning goal that you want to apply only between 1 and 100 rad/s. To restrict the tuning goal to this band, use the following command:

```
Req.Focus = [1,100];
```

Default: `[0,Inf]` for continuous time; `[0,pi/Ts]` for discrete time, where `Ts` is the model sample time.

Stabilize

Stability requirement on closed-loop dynamics, specified as 1 (`true`) or 0 (`false`).

When `Stabilize` is `true`, this requirement stabilizes the specified feedback loop, as well as imposing gain or loop-shape requirements. Set `Stabilize` to `false` if stability for the specified loop is not required or cannot be achieved.

Default: 1 (`true`)

LoopScaling

Toggle for automatically scaling loop signals, specified as `'on'` or `'off'`.

In multi-loop or MIMO control systems, the feedback channels are automatically rescaled to equalize the off-diagonal terms in the open-loop transfer function (loop interaction terms). Set `LoopScaling` to `'off'` to disable such scaling and shape the unscaled open-loop response.

Default: `'on'`

Location

Location at which the open-loop response shape to be constrained is measured, specified as a cell array of character vectors that identify one or more analysis points in the control system to tune. For example, if `Location = {'u'}`, the tuning goal evaluates the open-loop response measured at an analysis point `'u'`. If `Location = {'u1','u2'}`, the tuning goal evaluates the MIMO open-loop response measured at analysis points `'u1'` and `'u2'`.

The initial value of the `Location` property is set by the `location` input argument when you create the tuning goal.

Models

Models to which the tuning goal applies, specified as a vector of indices.

Use the `Models` property when tuning an array of control system models with `systune`, to enforce a tuning goal for a subset of models in the array. For example, suppose you want to apply the tuning goal, `Req`, to the second, third, and fourth models in a model array passed to `systune`. To restrict enforcement of the tuning goal, use the following command:

```
Req.Models = 2:4;
```

When `Models = NaN`, the tuning goal applies to all models.

Default: NaN

Openings

Feedback loops to open when evaluating the tuning goal, specified as a cell array of character vectors that identify loop-opening locations. The tuning goal is evaluated against the open-loop configuration created by opening feedback loops at the locations you identify.

If you are using the tuning goal to tune a Simulink model of a control system, then `Openings` can include any linear analysis point marked in the model, or any linear analysis point in an `sLTuner` interface associated with the Simulink model. Use `addPoint` to add analysis points and loop openings to the `sLTuner` interface. Use `getPoints` to get the list of analysis points available in an `sLTuner` interface to your model.

If you are using the tuning goal to tune a generalized state-space (`genss`) model of a control system, then `Openings` can include any `AnalysisPoint` location in the control system model. Use `getPoints` to get the list of analysis points available in the `genss` model.

For example, if `Openings = {'u1', 'u2'}`, then the tuning goal is evaluated with loops open at analysis points `u1` and `u2`.

Default: {}

Name

Name of the tuning goal, specified as a character vector.

For example, if `Req` is a tuning goal:

```
Req.Name = 'LoopReq';
```

Default: []

Examples

Loop Shape and Crossover Tolerance

Create a target gain profile requirement for the following control system. Specify integral action, gain crossover at 1, and a roll-off requirement of 40 dB/decade.

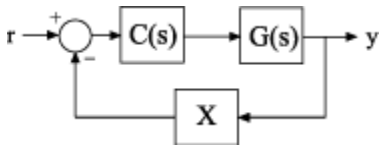

The requirement should apply to the open-loop response measured at the AnalysisPoint block X. Specify a crossover tolerance of 0.5 decades.

```
LS = frd([100 1 0.0001],[0.01 1 100]);
Req = TuningGoal.LoopShape('X',LS,0.5);
```

The software converts LS into a smooth function of frequency that approximates the piecewise-specified requirement. Display the requirement using viewGoal.

```
viewGoal(Req)
```

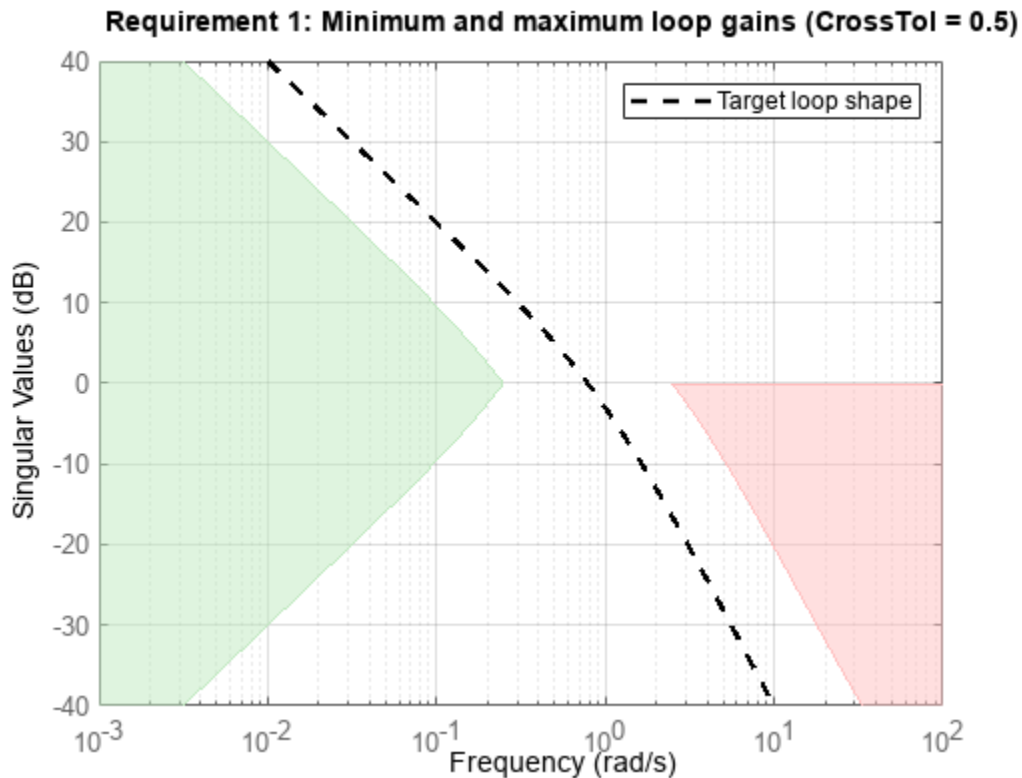

The green and red regions indicate the bounds for the inverse sensitivity, $\text{inv}(S) = 1 - G \cdot C$, and the complementary sensitivity, $T = 1 - S$, respectively. The gap between these regions at 0 dB gain reflects the specified crossover tolerance, which is half a decade to either side of the target loop crossover.

When you use `viewGoal(Req,CL)` to validate a tuned closed-loop model of this control system, CL, the tuned values of S and T are also plotted.

Specify Different Loop Shapes for Multiple Loops

Create separate loop shape requirements for the inner and outer loops of the following control system.

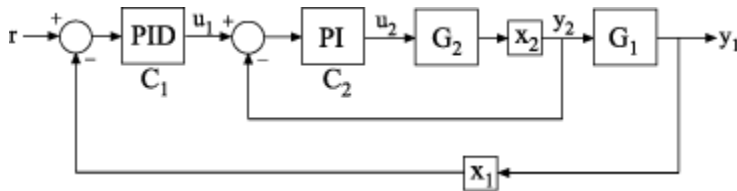

For the inner loop, specify a loop shape with integral action, gain crossover at 1, and a roll-off requirement of 40 dB/decade. Additionally, specify that this loop shape requirement should be enforced with the outer loop open.

```
LS2 = frd([100 1 0.0001],[0.01 1 100]);
Req2 = TuningGoal.LoopShape('X2',LS2);
Req2.Openings = 'X1';
```

Specifying 'X2' for the `location` indicates that Req2 applies to the point-to-point, open-loop transfer function at the location X2. Setting `Req2.Openings` indicates that the loop is opened at the analysis point X1 when Req2 is enforced.

By default, Req2 imposes a stability requirement on the inner loop as well as the loop shape requirement. In some control systems, however, inner-loop stability might not be required, or might be impossible to achieve. In that case, remove the stability requirement from Req2 as follows.

```
Req2.Stabilize = false;
```

For the outer loop, specify a loop shape with integral action, gain crossover at 0.1, and a roll-off requirement of 20 dB/decade.

```
LS1 = frd([10 1 0.01],[0.01 0.1 10]);
Req1 = TuningGoal.LoopShape('X1',LS1);
```

Specifying 'X1' for the `location` indicates that Req1 applies to the point-to-point, open-loop transfer function at the location X1. You do not have to set `Req1.Openings` because this loop shape is enforced with the inner loop closed.

You might want to tune the control system with both loop shaping requirements Req1 and Req2. To do so, use both requirements as inputs to the tuning command. For example, suppose `CL0` is a tunable `genss` model of the closed-loop control system. In that case, use `[CL, fSoft] = systune(CL0, [Req1, Req2])` to tune the control system to both requirements.

Loop Shape for Tuning Simulink Model

Create a loop-shape requirement for the feedback loop on 'q' in the Simulink model `rct_airframe2`. Specify that the loop-shape requirement is enforced with the 'az' loop open.

Open the model.

```
open_system('rct_airframe2')
```

Two-loop autopilot for controlling the vertical acceleration of an airframe

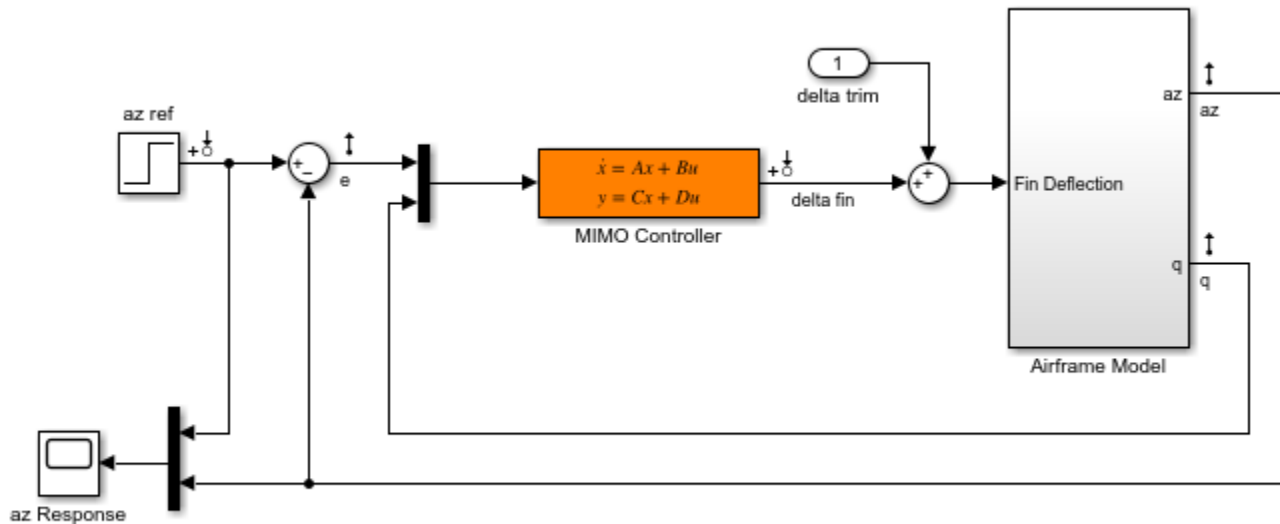

Copyright 2014 The MathWorks, Inc.

Create a loop shape requirement that enforces integral action with a crossover a 2 rad/s for the 'q' loop. This loop shape corresponds to a loop shape of $2/s$.

```
s = tf('s');
shape = 2/s;
Req = TuningGoal.LoopShape('q', shape);
```

Specify the location at which to open an additional loop when enforcing the requirement.

```
Req.Openings = 'az';
```

To use this requirement to tune the Simulink model, create an sITuner interface to the model. Identify the block to tune in the interface.

```
ST0 = sITuner('rct_airframe2', 'MIMO Controller');
```

Designate both az and q as analysis points in the sITuner interface.

```
addPoint(ST0, {'az', 'q'});
```

This command makes q available as an analysis location. It also allows the tuning requirement to be enforced with the loop open at az.

You can now tune the model using Req and any other tuning requirements. For example:

```
[ST, fSoft] = systune(ST0, Req);
```

```
Final: Soft = 0.845, Hard = -Inf, Iterations = 51
```

Loop Shape Requirement with Crossover Range

Create a tuning requirement specifying that the open-loop response of loop identified by 'X' cross unity gain between 50 and 100 rad/s.

```
Req = TuningGoal.LoopShape('X',[50,100]);
```

Examine the resulting requirement to see the target loop shape.

```
viewGoal(Req)
```



The plot shows that the requirement specifies an integral loop shape, with crossover around 70 rad/s, the geometrical mean of the range [50,100]. The gap at 0 dB between the minimum low-frequency gain (green region) and the maximum high-frequency gain (red region) reflects the allowed crossover range [50,100].

Tips

- This tuning goal imposes an implicit stability constraint on the closed-loop sensitivity function measured at `Location`, evaluated with loops opened at the points identified in `Openings`. The dynamics affected by this implicit constraint are the stabilized dynamics for this tuning goal. The `MinDecay` and `MaxRadius` options of `systemOptions` control the bounds on these implicitly constrained dynamics. If the optimization fails to meet the default bounds, or if the default bounds conflict with other requirements, use `systemOptions` to change these defaults.

Algorithms

When you tune a control system using a `TuningGoal`, the software converts the tuning goal into a normalized scalar value $f(x)$, where x is the vector of free (tunable) parameters in the control system. The software then adjusts the parameter values to minimize $f(x)$ or to drive $f(x)$ below 1 if the tuning goal is a hard constraint.

For `TuningGoal.LoopShape`, $f(x)$ is given by:

$$f(x) = \left\| \frac{W_S S}{W_T T} \right\|_{\infty}.$$

Here, $S = D^{-1}[I - L(s,x)]^{-1}D$ is the scaled sensitivity function at the specified location, where $L(s,x)$ is the open-loop response being shaped. D is an automatically-computed loop scaling factor. (If the `LoopScaling` property is set to 'off', then $D = I$.) $T = S - I$ is the complementary sensitivity function.

W_S and W_T are frequency weighting functions derived from the specified loop shape. The gains of these functions roughly match `LoopGain` and `1/LoopGain`, for values ranging from -20 dB to 60 dB. For numerical reasons, the weighting functions level off outside this range, unless the specified loop gain profile changes slope for gains above 60 dB or below -60 dB. Because poles of W_S or W_T close to $s = 0$ or $s = \text{Inf}$ might lead to poor numeric conditioning of the `system` optimization problem, it is not recommended to specify loop shapes with very low-frequency or very high-frequency dynamics.

To obtain W_S and W_T , use:

```
[WS,WT] = getWeights(Req,Ts)
```

where `Req` is the tuning goal, and `Ts` is the sample time at which you are tuning (`Ts = 0` for continuous time). For more information about the effects of the weighting functions on numeric stability, see “Visualize Tuning Goals”.

Version History

Introduced in R2016a

Functionality moved from Robust Control Toolbox

Behavior changed in R2016a

Prior to R2016a, this functionality required a Robust Control Toolbox license.

See Also

`looptune` | `system` | `looptune` (for `sITuner`) | `system` (for `sITuner`) | `TuningGoal.MinLoopGain` | `TuningGoal.MaxLoopGain` | `viewGoal` | `TuningGoal.Tracking` | `TuningGoal.Gain` | `sITuner` | `frd`

Topics

“Loop Shape and Stability Margin Specifications”

“Visualize Tuning Goals”

“Tuning Multiloop Control Systems”

“Tuning of a Digital Motion Control System”

TuningGoal.LQG class

Package: TuningGoal

Linear-Quadratic-Gaussian (LQG) goal for control system tuning

Description

Use `TuningGoal.LQG` to specify a tuning goal that quantifies control performance as an LQG cost. It is applicable to any control structure, not just the classical observer structure of optimal LQG control. You can use this tuning goal for control system tuning with tuning commands, such as `systemtune` or `looptune`.

The LQG cost is given by:

$$J = E(z(t)' QZ z(t)).$$

$z(t)$ is the system response to a white noise input vector $w(t)$. The covariance of $w(t)$ is given by:

$$E(w(t)w(t)') = QW.$$

The vector $w(t)$ typically consists of external inputs to the system such as noise, disturbances, or command. The vector $z(t)$ includes all the system variables that characterize performance, such as control signals, system states, and outputs. $E(x)$ denotes the expected value of the stochastic variable x .

The cost function J can also be written as an average over time:

$$J = \lim_{T \rightarrow \infty} E\left(\frac{1}{T} \int_0^T z(t)' QZ z(t) dt\right).$$

After you create a tuning goal, you can further configure it by setting “Properties” on page 1-37 of the object.

Construction

`Req = TuningGoal.LQG(wname, zname, QW, QZ)` creates an LQG requirement. `wname` and `zname` specify the signals making up $w(t)$ and $z(t)$. The matrices `QW` and `QZ` specify the noise covariance and performance weight. These matrices must be symmetric nonnegative definite. Use scalar values for `QW` and `QZ` to specify multiples of the identity matrix.

Input Arguments

wname

Noise inputs, $w(t)$, specified as a character vector or a cell array of character vectors, that designate the signals making up $w(t)$ by name, such as `'w'` or `{'w', 'v'}`. The signals available to designate as noise inputs for the tuning goal are as follows.

- If you are using the tuning goal to tune a Simulink model of a control system, then `wname` can include:

- Any model input
- Any linearization input point in the model
- Any signal identified as a Controls, Measurements, Switches, or IOs signal in an sLTuner interface associated with the Simulink model
- If you are using the tuning goal to tune a generalized state-space model (genss) of a control system using systune, then wname can include:
 - Any input of the control system model
 - Any channel of an AnalysisPoint block in the control system model

For example, if you are tuning a control system model, T, then wname can be an input name contained in T.InputName. Also, if T contains an AnalysisPoint block with a location named X, then wname can include X.

- If you are using the tuning goal to tune a controller model, C0 for a plant G0, using looptune, then wname can include:
 - Any input of C0 or G0
 - Any channel of an AnalysisPoint block in C0 or G0

If wname is a channel of an AnalysisPoint block of a generalized model, the noise input for the tuning goal is the implied input associated with the switch:



zname

Performance outputs, $z(t)$, specified as a character vector or a cell array of character vectors, that designate the signals making up $z(t)$ by name, such as 'y' or {'y', 'u'}. The signals available to designate as performance outputs for the tuning goal are as follows.

- If you are using the tuning goal to tune a Simulink model of a control system, then zname can include:
 - Any model output
 - Any linearization output point in the model
 - Any signal identified as a Controls, Measurements, Switches, or IOs signal in an sLTuner interface associated with the Simulink model
- If you are using the tuning goal to tune a generalized state-space model (genss) of a control system using systune, then zname can include:
 - Any output of the control system model
 - Any channel of an AnalysisPoint block in the control system model

For example, if you are tuning a control system model, T, then zname can be an output name contained in T.OutputName. Also, if T contains an AnalysisPoint block with a channel named X, then zname can include X.

- If you are using the tuning goal to tune a controller model, $C0$ for a plant $G0$, using `looptune`, then `zname` can include:
 - Any input of $C0$ or $G0$
 - Any channel of an `AnalysisPoint` block in $C0$ or $G0$

If `zname` is a channel of an `AnalysisPoint` block of a generalized model, the performance output for the tuning goal is the implied output associated with the switch:



QW

Covariance of the white noise input vector $w(t)$, specified as a scalar or a matrix. Use a scalar value to specify a multiple of the identity matrix. Otherwise specify a symmetric nonnegative definite matrix with as many rows as there are entries in the vector $w(t)$. A diagonal matrix means the entries of $w(t)$ are uncorrelated.

The covariance of $w(t)$ is given by:

$$E(w(t)w(t)') = QW.$$

When you are tuning a control system in discrete time, the LQG tuning goal assumes:

$$E(w[k]w[k]') = QW/T_s.$$

T_s is the model sample time. This assumption ensures consistent results with tuning in the continuous-time domain. In this assumption, $w[k]$ is discrete-time noise obtained by sampling continuous white noise $w(t)$ with covariance QW . If in your system $w[k]$ is a truly discrete process with known covariance QWd , use the value T_s*QWd for the QW value when creating the LQG goal.

Default: I

QZ

Performance weights, specified as a scalar or a matrix. Use a scalar value to specify a multiple of the identity matrix. Otherwise specify a symmetric nonnegative definite matrix. Use a diagonal matrix to independently scale or penalize the contribution of each variable in z .

The performance weights contribute to the cost function according to:

$$J = E(z(t)' QZ z(t)).$$

When you use the LQG tuning goal as a hard goal, the software tries to drive the cost function $J < 1$. When you use it as a soft goal, the cost function J is minimized subject to any hard goals and its value is contributed to the overall objective function. Therefore, select QZ values to properly scale the cost function so that driving it below 1 or minimizing it yields the performance you require.

Default: I

Properties

NoiseCovariance

Covariance matrix of the noise inputs $w(t)$, specified as a matrix. The value of the `NoiseCovariance` property is set by the `WZ` input argument when you create the LQG tuning goal.

PerformanceWeight

Weights for the performance signals $z(t)$, specified as a matrix. The value of the `PerformanceWeight` property is set by the `QZ` input argument when you create the LQG tuning goal.

Input

Noise input signal names, specified as a cell array of character vectors. The input signal names specify the inputs of the transfer function that the tuning goal constrains. The initial value of the `Input` property is set by the `wname` input argument when you construct the tuning goal.

Output

Performance output signal names, specified as a cell array of character vectors. The output signal names specify the outputs of the transfer function that the tuning goal constrains. The initial value of the `Output` property is set by the `zname` input argument when you construct the tuning goal.

Models

Models to which the tuning goal applies, specified as a vector of indices.

Use the `Models` property when tuning an array of control system models with `systune` , to enforce a tuning goal for a subset of models in the array. For example, suppose you want to apply the tuning goal, `Req`, to the second, third, and fourth models in a model array passed to `systune` . To restrict enforcement of the tuning goal, use the following command:

```
Req.Models = 2:4;
```

When `Models = NaN`, the tuning goal applies to all models.

Default: NaN

Openings

Feedback loops to open when evaluating the tuning goal, specified as a cell array of character vectors that identify loop-opening locations. The tuning goal is evaluated against the open-loop configuration created by opening feedback loops at the locations you identify.

If you are using the tuning goal to tune a Simulink model of a control system, then `Openings` can include any linear analysis point marked in the model, or any linear analysis point in an `sLTuner` interface associated with the Simulink model. Use `addPoint` to add analysis points and loop openings to the `sLTuner` interface. Use `getPoints` to get the list of analysis points available in an `sLTuner` interface to your model.

If you are using the tuning goal to tune a generalized state-space (`genss`) model of a control system, then `Openings` can include any `AnalysisPoint` location in the control system model. Use `getPoints` to get the list of analysis points available in the `genss` model.

For example, if `Openings = {'u1', 'u2'}`, then the tuning goal is evaluated with loops open at analysis points `u1` and `u2`.

Default: `{}`

Name

Name of the tuning goal, specified as a character vector.

For example, if `Req` is a tuning goal:

```
Req.Name = 'LoopReq';
```

Default: `[]`

Tips

- When you use this tuning goal to tune a continuous-time control system, `systemtune` attempts to enforce zero feedthrough ($D = 0$) on the transfer that the tuning goal constrains. Zero feedthrough is imposed because the H_2 norm, and therefore the value of the tuning goal, is infinite for continuous-time systems with nonzero feedthrough.

`systemtune` enforces zero feedthrough by fixing to zero all tunable parameters that contribute to the feedthrough term. `systemtune` returns an error when fixing these tunable parameters is insufficient to enforce zero feedthrough. In such cases, you must modify the tuning goal or the control structure, or manually fix some tunable parameters of your system to values that eliminate the feedthrough term.

When the constrained transfer function has several tunable blocks in series, the software's approach of zeroing all parameters that contribute to the overall feedthrough might be conservative. In that case, it is sufficient to zero the feedthrough term of one of the blocks. If you want to control which block has feedthrough fixed to zero, you can manually fix the feedthrough of the tuned block of your choice.

To fix parameters of tunable blocks to specified values, use the `Value` and `Free` properties of the block parametrization. For example, consider a tuned state-space block:

```
C = tunableSS('C',1,2,3);
```

To enforce zero feedthrough on this block, set its D matrix value to zero, and fix the parameter.

```
C.D.Value = 0;  
C.D.Free = false;
```

For more information on fixing parameter values, see the Control Design Block reference pages, such as `tunableSS`.

- This tuning goal imposes an implicit stability constraint on the closed-loop transfer function from `wname` to `zname`, evaluated with loops opened at the points identified in `Openings`. The dynamics affected by this implicit constraint are the stabilized dynamics for this tuning goal. The `MinDecay` and `MaxRadius` options of `systemtuneOptions` control the bounds on these implicitly constrained dynamics. If the optimization fails to meet the default bounds, or if the default bounds conflict with other requirements, use `systemtuneOptions` to change these defaults.

Algorithms

When you tune a control system using a `TuningGoal`, the software converts the tuning goal into a normalized scalar value $f(x)$. x is the vector of free (tunable) parameters in the control system. The software then adjusts the parameter values to minimize $f(x)$, or to drive $f(x)$ below 1 if the tuning goal is a hard constraint.

For `TuningGoal.LQG`, $f(x)$ is given by the cost function J :

$$J = E(z(t)' QZ z(t)).$$

When you use the LQG requirement as a hard goal, the software tries to drive the cost function $J < 1$. When you use it as a soft goal, the cost function J is minimized subject to any hard goals and its value is contributed to the overall objective function. Therefore, select `QZ` values to properly scale the cost function so that driving it below 1 or minimizing it yields the performance you require.

Version History

Introduced in R2016a

Functionality moved from Robust Control Toolbox

Behavior changed in R2016a

Prior to R2016a, this functionality required a Robust Control Toolbox license.

See Also

`systemtune` | `slTuner` | `systemtune (for slTuner)` | `viewGoal` | `evalGoal` | `TuningGoal.WeightedVariance` | `TuningGoal.Variance`

Topics

“Vibration Control in Flexible Beam”

“Time-Domain Specifications”

TuningGoal.Margins class

Package: TuningGoal

Stability margin requirement for control system tuning

Description

Use `TuningGoal.Margins` to specify a tuning goal for the gain and phase margins of a SISO or MIMO feedback loop. You can use this tuning goal for validating a tuned control system with `viewGoal`. You can also use the tuning goal for control system tuning with tuning commands such as `systemtune` or `looptune`.

After you create a tuning goal, you can configure it further by setting “Properties” on page 1-41 of the object.

After using the tuning goal to tune a control system, you can visualize the tuning goal and the tuned value using the `viewGoal` command. For information about interpreting the margins goal, see “Stability Margins in Control System Tuning”.

Construction

`Req = TuningGoal.Margins(location, gainmargin, phasemargin)` creates a tuning goal that specifies the minimum gain and phase margins at the specified location in the control system.

Input Arguments

location

Location in the control system at which the minimum gain and phase margins apply, specified as a character vector or cell array of character vectors that identify one or more locations in the control system to tune. What locations are available depends on what kind of system you are tuning:

- If you are tuning a Simulink model of a control system, you can use any linear analysis point marked in the model, or any linear analysis point in an `sLTuner` interface associated with the Simulink model. Use `addPoint` to add analysis points to the `sLTuner` interface. For example, if the `sLTuner` interface contains an analysis point `u`, you can use `'u'` to refer to that point when creating tuning goals. Use `getPoints` to get the list of analysis points available in an `sLTuner` interface to your model.
- If you are tuning a generalized state-space (`genss`) model of a control system, you can use any `AnalysisPoint` location in the control system model. For example, the following code creates a PI loop with an analysis point at the plant input `'u'`.

```
AP = AnalysisPoint('u');  
G = tf(1,[1 2]);  
C = tunablePID('C','pi');  
T = feedback(G*AP*C,1);
```

When creating tuning goals, you can use `'u'` to refer to the analysis point at the plant input. Use `getPoints` to get the list of analysis points available in a `genss` model.

The margin requirements apply to the point-to-point, open-loop transfer function at the specified loop-opening location. That transfer function is the open-loop response obtained by injecting signals at the specified location, and measuring the return signals at the same point.

If `location` is a cell array, then the margin requirement applies to the MIMO open-loop transfer function.

gainmargin

Required minimum gain margin for the feedback loop, specified as a scalar value in dB. `TuningGoal.Margins` uses disk-based gain and phase margins, which provide a stronger guarantee of stability than the classical gain and phase margins. (For details about disk margins, see “Stability Analysis Using Disk Margins” (Robust Control Toolbox).)

The gain margin indicates how much the gain of the open-loop response can increase or decrease without loss of stability. For instance,

- For a SISO system, setting `gainmargin = 3` specifies a requirement that the closed-loop system remain stable for changes in the open-loop gain of up to ± 3 dB.
- For a MIMO system, setting `gainmargin = 3` specifies a requirement that the closed-system remain stable for gain changes up to ± 3 dB in each feedback channel. The gain can change in all channels simultaneously, and by a different amount in each channel.

phasemargin

Required minimum phase margin for the feedback loop, specified as a scalar value in degrees. `TuningGoal.Margins` uses disk-based gain and phase margins, which provide a stronger guarantee of stability than the classical gain and phase margins. (For details about disk margins, see “Stability Analysis Using Disk Margins” (Robust Control Toolbox).)

The phase margin indicates how much the phase of the open-loop response can increase or decrease without loss of stability. For instance,

- For a SISO system, setting `phasemargin = 45` specifies a requirement that the closed-loop system remain stable for changes of up to $\pm 45^\circ$ in the phase of the open-loop response.
- For a MIMO system, setting `phasemargin = 45` specifies a requirement that the closed-system remain stable for phase changes up to $\pm 45^\circ$ in each feedback channel. The phase can change in all channels simultaneously, and by a different amount in each channel.

Properties

GainMargin

Required minimum gain margin for the feedback loop, specified as a scalar value in decibels (dB).

The value of the `GainMargin` property is set by the `gainmargin` input argument when you create the tuning goal.

PhaseMargin

Required minimum phase margin for the feedback loop, specified as a scalar value in degrees.

The value of the `PhaseMargin` property is set by the `phasemargin` input argument when you create the tuning goal.

ScalingOrder

Controls the order (number of states) of the scalings involved in computing MIMO stability margins. Static scalings (`ScalingOrder = 0`) are used by default. Increasing the order may improve results at the expense of increased computations. Use `viewGoal` to assess the gap between optimized and actual margins. If this gap is too large, consider increasing the scaling order. See “Stability Margins in Control System Tuning”.

Default: 0 (static scaling)

Focus

Frequency band in which tuning goal is enforced, specified as a row vector of the form `[min,max]`.

Set the `Focus` property to limit enforcement of the tuning goal to a particular frequency band. For best results with stability margin requirements, pick a frequency band extending about one decade on each side of the gain crossover frequencies. For example, suppose `Req` is a `TuningGoal.Margins` object that you are using to tune a system with approximately 10 rad/s bandwidth. To limit the enforcement of the tuning goal, use the following command:

```
Req.Focus = [1,100];
```

Default: `[0,Inf]` for continuous time; `[0,pi/Ts]` for discrete time, where `Ts` is the model sample time.

Location

Location at which the minimum gain and phase margins apply, specified as a cell array of character vectors that identify one or more analysis points in the control system to tune. For example, if `Location = {'u'}`, the tuning goal enforces the minimum gain and phase margins at an analysis point 'u'.

The value of the `Location` property is set by the `location` input argument when you create the tuning goal.

Models

Models to which the tuning goal applies, specified as a vector of indices.

Use the `Models` property when tuning an array of control system models with `systemtune`, to enforce a tuning goal for a subset of models in the array. For example, suppose you want to apply the tuning goal, `Req`, to the second, third, and fourth models in a model array passed to `systemtune`. To restrict enforcement of the tuning goal, use the following command:

```
Req.Models = 2:4;
```

When `Models = NaN`, the tuning goal applies to all models.

Default: NaN

Openings

Feedback loops to open when evaluating the tuning goal, specified as a cell array of character vectors that identify loop-opening locations. The tuning goal is evaluated against the open-loop configuration created by opening feedback loops at the locations you identify.

If you are using the tuning goal to tune a Simulink model of a control system, then `Openings` can include any linear analysis point marked in the model, or any linear analysis point in an `sLTuner` interface associated with the Simulink model. Use `addPoint` to add analysis points and loop openings to the `sLTuner` interface. Use `getPoints` to get the list of analysis points available in an `sLTuner` interface to your model.

If you are using the tuning goal to tune a generalized state-space (`genss`) model of a control system, then `Openings` can include any `AnalysisPoint` location in the control system model. Use `getPoints` to get the list of analysis points available in the `genss` model.

For example, if `Openings = {'u1', 'u2'}`, then the tuning goal is evaluated with loops open at analysis points `u1` and `u2`.

Default: `{}`

Name

Name of the tuning goal, specified as a character vector.

For example, if `Req` is a tuning goal:

```
Req.Name = 'LoopReq';
```

Default: `[]`

Examples

SISO Margin Requirement Evaluated with Additional Loop Opening

Create a margin requirement for the inner loop of the following control system. The requirement imposes a minimum gain margin of 5 dB and a minimum phase margin of 40 degrees.

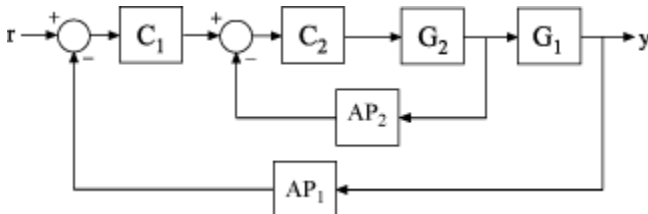

Create a model of the system. To do so, specify and connect the numeric plant models `G1` and `G2`, and the tunable controllers `C1` and `C2`. Also specify and connect the `AnalysisPoint` blocks `AP1` and `AP2` that mark points of interest for analysis and tuning.

```
G1 = tf(10,[1 10]);
G2 = tf([1 2],[1 0.2 10]);
C1 = tunablePID('C','pi');
C2 = tunableGain('G',1);
AP1 = AnalysisPoint('AP1');
AP2 = AnalysisPoint('AP2');
T = feedback(G1*feedback(G2*C2,AP2)*C1,AP1);
```

Create a tuning requirement object.

```
Req = TuningGoal.Margins('AP2',5,40);
```

This requirement imposes the specified stability margins on the feedback loop identified by the `AnalysisPoint` channel 'AP2', which is the inner loop.

Specify that these margins are evaluated with the outer loop of the control system open.

```
Req.Openings = {'AP1'};
```

Adding 'AP1' to the `Openings` property of the tuning requirements object ensures that `systune` evaluates the requirement with the loop open at that location.

Use `systune` to tune the free parameters of `T` to meet the tuning requirement specified by `Req`. You can then use `viewGoal` to validate the tuned control system against the requirement.

MIMO Margin Requirement in Frequency Band

Create a requirement that sets minimum gain and phase margins for the loop defined by three loop-opening locations in a control system to tune. Because this loop is defined by three loop-opening locations, it is a MIMO loop.

The requirement sets a minimum gain margin of 10 dB and a minimum phase margin of 40 degrees, within the band between 0.1 and 10 rad/s.

```
Req = TuningGoal.Margins({'r', 'theta', 'phi'}, 10, 40);
```

The names 'r', 'theta', and 'phi' must specify valid loop-opening locations in the control system that you are tuning.

Limit the requirement to the frequency band between 0.1 and 10 rad/s.

```
Req.Focus = [0.1 10];
```

Tips

- This tuning goal imposes an implicit stability constraint on the closed-loop sensitivity function measured at `Location`, evaluated with loops opened at the points identified in `Openings`. The dynamics affected by this implicit constraint are the stabilized dynamics for this tuning goal. The `MinDecay` and `MaxRadius` options of `systuneOptions` control the bounds on these implicitly constrained dynamics. If the optimization fails to meet the default bounds, or if the default bounds conflict with other requirements, use `systuneOptions` to change these defaults.

Algorithms

When you tune a control system using a `TuningGoal`, the software converts the tuning goal into a normalized scalar value $f(x)$, where x is the vector of free (tunable) parameters in the control system. The software then adjusts the parameter values to minimize $f(x)$ or to drive $f(x)$ below 1 if the tuning goal is a hard constraint.

For `TuningGoal.Margins`, $f(x)$ is given by:

$$f(x) = \|2\alpha S - \alpha I\|_{\infty}.$$

$S = D^{-1}[I - L(s,x)]^{-1}D$ is the scaled sensitivity function.

$L(s,x)$ is the open-loop response being shaped.

D is an automatically-computed loop scaling factor. For more information about D , see “Stability Margins in Control System Tuning”.

α is a scalar parameter computed from the specified gain and phase margin. For more information about α , see “Stability Analysis Using Disk Margins” (Robust Control Toolbox).

Version History

Introduced in R2016a

Functionality moved from Robust Control Toolbox

Behavior changed in R2016a

Prior to R2016a, this functionality required a Robust Control Toolbox license.

See Also

`looptune` | `system` | `system` (for `sITuner`) | `looptune` (for `sITuner`) | `viewGoal` | `evalGoal`

Topics

“Loop Shape and Stability Margin Specifications”
“Tune Control Systems with SYSTUNE”
“Digital Control of Power Stage Voltage”
“Tuning of a Two-Loop Autopilot”
“Fixed-Structure Autopilot for a Passenger Jet”
“Stability Margins in Control System Tuning”

TuningGoal.MinLoopGain class

Package: TuningGoal

Minimum loop gain constraint for control system tuning

Description

Use the `TuningGoal.MinLoopGain` object to enforce a minimum loop gain in a particular frequency band. Use this tuning goal with control system tuning commands such as `systemtune` or `looptune`.

This tuning goal imposes a minimum gain on the open-loop frequency response (L) at a specified location in your control system. You specify the minimum open-loop gain as a function of frequency (a minimum gain profile). For MIMO feedback loops, the specified gain profile is interpreted as a lower bound on the smallest singular value of L .

When you tune a control system, the minimum gain profile is converted to a minimum gain constraint on the inverse of the sensitivity function, $\text{inv}(S) = (I + L)$.

The following figure shows a typical specified minimum gain profile (dashed line) and a resulting tuned loop gain, L (blue line). The shaded region represents gain profile values that are forbidden by this tuning goal. The figure shows that when L is much larger than 1, imposing a minimum gain on $\text{inv}(S)$ is a good proxy for a minimum open-loop gain.

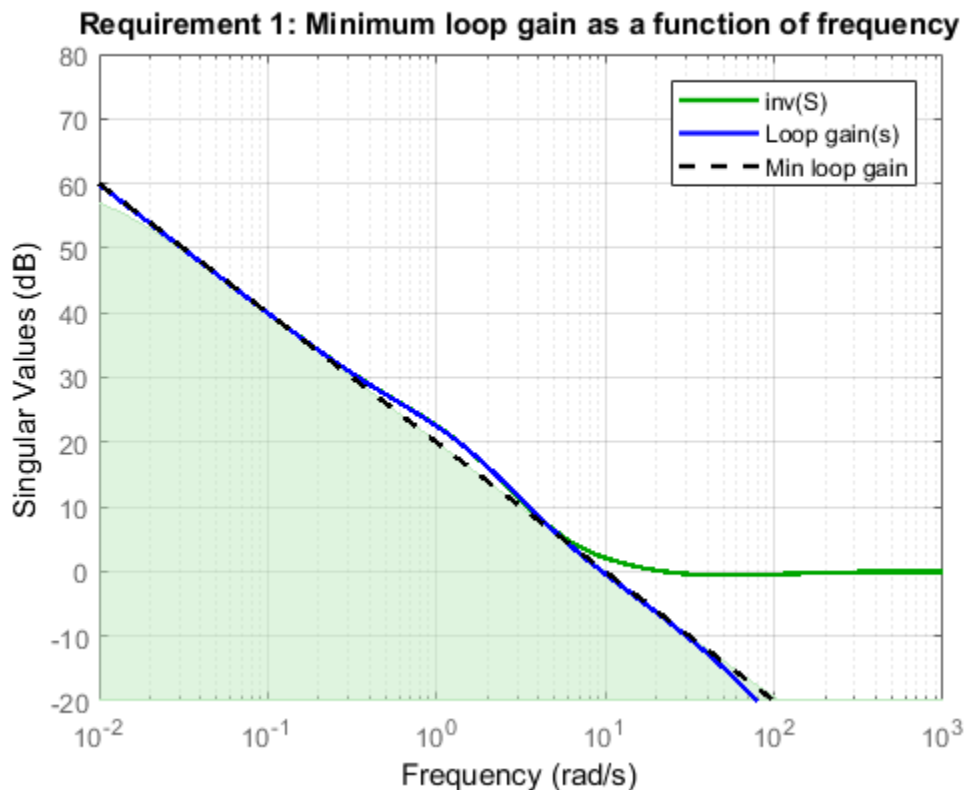

`TuningGoal.MinLoopGain` and `TuningGoal.MaxLoopGain` specify only low-gain or high-gain constraints in certain frequency bands. When you use these tuning goals, `systemtune` and `looptune` determine the best loop shape near crossover. When the loop shape near crossover is simple or well understood (such as integral action), you can use `TuningGoal.LoopShape` to specify that target loop shape.

Construction

`Req = TuningGoal.MinLoopGain(location, loopgain)` creates a tuning goal for boosting the gain of a SISO or MIMO feedback loop. The tuning goal specifies that the open-loop frequency response (L) measured at the specified locations exceeds the minimum gain profile specified by `loopgain`.

You can specify the minimum gain profile as a smooth transfer function or sketch a piecewise error profile using an `frd` model or the `makeweight` command. Only gain values greater than 1 are enforced.

For MIMO feedback loops, the specified gain profile is interpreted as a lower bound on the smallest singular value of L .

`Req = TuningGoal.MinLoopGain(location, fmin, gmin)` specifies a minimum gain profile of the form $\text{loopgain} = K/s$ (integral action). The software chooses K such that the gain value is `gmin` at the specified frequency, `fmin`.

Input Arguments

location

Location at which the maximum open-loop gain is constrained, specified as a character vector or cell array of character vectors that identify one or more locations in the control system to tune. What loop-opening locations are available depends on what kind of system you are tuning:

- If you are tuning a Simulink model of a control system, you can use any linear analysis point marked in the model, or any linear analysis point in an `sLTuner` interface associated with the Simulink model. Use `addPoint` to add analysis points to the `sLTuner` interface. For example, if the `sLTuner` interface contains an analysis point `u`, you can use `'u'` to refer to that point when creating tuning goals. Use `getPoints` to get the list of analysis points available in an `sLTuner` interface to your model.
- If you are tuning a generalized state-space (`genss`) model of a control system, you can use any `AnalysisPoint` location in the control system model. For example, the following code creates a PI loop with an analysis point at the plant input `'u'`.

```
AP = AnalysisPoint('u');
G = tf(1,[1 2]);
C = tunablePID('C','pi');
T = feedback(G*AP*C,1);
```

When creating tuning goals, you can use `'u'` to refer to the analysis point at the plant input. Use `getPoints` to get the list of analysis points available in a `genss` model.

If `location` is a cell array of loop-opening locations, then the minimum gain goal applies to the resulting MIMO loop.

loopgain

Minimum open-loop gain as a function of frequency.

You can specify `loopgain` as a smooth SISO transfer function (`tf`, `zpk`, or `ss` model). Alternatively, you can sketch a piecewise gain profile using a `frd` model or the `makeweight` command. For example, the following `frd` model specifies a minimum gain of 100 (40 dB) below 0.1 rad/s, rolling off at a rate of -20 dB/dec at higher frequencies.

```
loopgain = frd([100 100 10],[0 1e-1 1]);
```

When you use an `frd` model to specify `loopgain`, the software automatically maps your specified gain profile to a `zpk` model. The magnitude of this model approximates the desired gain profile. Use `viewGoal(Req)` to plot the magnitude of that `zpk` model.

Only gain values larger than 1 are enforced. For multi-input, multi-output (MIMO) feedback loops, the gain profile is interpreted as a lower bound on the smallest singular value of L . For more information about singular values, see `sigma`.

If you are tuning in discrete time (that is, using a `genss` model or `sLTuner` interface with nonzero T_s), you can specify `loopgain` as a discrete-time model with the same T_s . If you specify `loopgain` in continuous time, the tuning software discretizes it. Specifying the loop gain in discrete time gives you more control over the loop gain near the Nyquist frequency.

fmin

Frequency of minimum gain `gmin`, specified as a scalar value in rad/s.

Use this argument to specify a minimum gain profile of the form `loopgain = K/s` (integral action). The software chooses K such that the gain value is `gmin` at the specified frequency, `fmin`.

gmin

Value of minimum gain occurring at `fmin`, specified as a scalar absolute value.

Use this argument to specify a minimum gain profile of the form `loopgain = K/s` (integral action). The software chooses K such that the gain value is `gmin` at the specified frequency, `fmin`.

Properties

MinGain

Minimum open-loop gain as a function of frequency, specified as a SISO `zpk` model.

The software automatically maps the input argument `loopgain` onto a `zpk` model. The magnitude of this `zpk` model approximates the desired gain profile. Alternatively, if you use the `fmin` and `gmin` arguments to specify the gain profile, this property is set to `K/s`. The software chooses K such that the gain value is `gmin` at the specified frequency, `fmin`.

Use `viewGoal(Req)` to plot the magnitude of the open-loop minimum gain profile.

Focus

Frequency band in which tuning goal is enforced, specified as a row vector of the form `[min,max]`.

Set the `Focus` property to limit enforcement of the tuning goal to a particular frequency band. Express this value in the frequency units of the control system model you are tuning (rad/TimeUnit). For example, suppose `Req` is a tuning goal that you want to apply only between 1 and 100 rad/s. To restrict the tuning goal to this band, use the following command:

```
Req.Focus = [1,100];
```

Default: `[0,Inf]` for continuous time; `[0,pi/Ts]` for discrete time, where `Ts` is the model sample time.

Stabilize

Stability requirement on closed-loop dynamics, specified as 1 (`true`) or 0 (`false`).

When `Stabilize` is `true`, this requirement stabilizes the specified feedback loop, as well as imposing gain or loop-shape requirements. Set `Stabilize` to `false` if stability for the specified loop is not required or cannot be achieved.

Default: 1 (`true`)

LoopScaling

Toggle for automatically scaling loop signals, specified as 'on' or 'off'.

In multi-loop or MIMO control systems, the feedback channels are automatically rescaled to equalize the off-diagonal terms in the open-loop transfer function (loop interaction terms). Set `LoopScaling` to 'off' to disable such scaling and shape the unscaled open-loop response.

Default: 'on'

Location

Location at which minimum loop gain is constrained, specified as a cell array of character vectors that identify one or more analysis points in the control system to tune. For example, if `Location = {'u'}`, the tuning goal evaluates the open-loop response measured at an analysis point 'u'. If `Location = {'u1', 'u2'}`, the tuning goal evaluates the MIMO open-loop response measured at analysis points 'u1' and 'u2'.

The value of the `Location` property is set by the `location` input argument when you create the tuning goal.

Models

Models to which the tuning goal applies, specified as a vector of indices.

Use the `Models` property when tuning an array of control system models with `systemtune`, to enforce a tuning goal for a subset of models in the array. For example, suppose you want to apply the tuning goal, `Req`, to the second, third, and fourth models in a model array passed to `systemtune`. To restrict enforcement of the tuning goal, use the following command:

```
Req.Models = 2:4;
```

When `Models = NaN`, the tuning goal applies to all models.

Default: NaN

Openings

Feedback loops to open when evaluating the tuning goal, specified as a cell array of character vectors that identify loop-opening locations. The tuning goal is evaluated against the open-loop configuration created by opening feedback loops at the locations you identify.

If you are using the tuning goal to tune a Simulink model of a control system, then `Openings` can include any linear analysis point marked in the model, or any linear analysis point in an `sLTuner` interface associated with the Simulink model. Use `addPoint` to add analysis points and loop openings to the `sLTuner` interface. Use `getPoints` to get the list of analysis points available in an `sLTuner` interface to your model.

If you are using the tuning goal to tune a generalized state-space (`genss`) model of a control system, then `Openings` can include any `AnalysisPoint` location in the control system model. Use `getPoints` to get the list of analysis points available in the `genss` model.

For example, if `Openings = {'u1', 'u2'}`, then the tuning goal is evaluated with loops open at analysis points `u1` and `u2`.

Default: `{}`

Name

Name of the tuning goal, specified as a character vector.

For example, if `Req` is a tuning goal:

```
Req.Name = 'LoopReq';
```

Default: `[]`

Examples

Minimum Loop Gain Tuning Goal

Create a tuning goal that boosts the open-loop gain of a feedback loop to at least a specified profile.

Suppose that you are tuning a control system that has a loop-opening location identified by `PILoop`. Specify that the open-loop gain measured at that location exceeds a minimum gain of 10 (20 dB) below 0.1 rad/s, rolling off at a rate of -20 dB/dec at higher frequencies. Use an `frd` model to sketch this gain profile.

```
loopgain = frd([10 10 0.1],[0 1e-1 10]);  
Req = TuningGoal.MinLoopGain('PILoop',loopgain);
```

The software converts `loopgain` into a smooth function of frequency that approximates the piecewise-specified gain profile. Display the tuning goal using `viewGoal`.

```
viewGoal(Req)
```

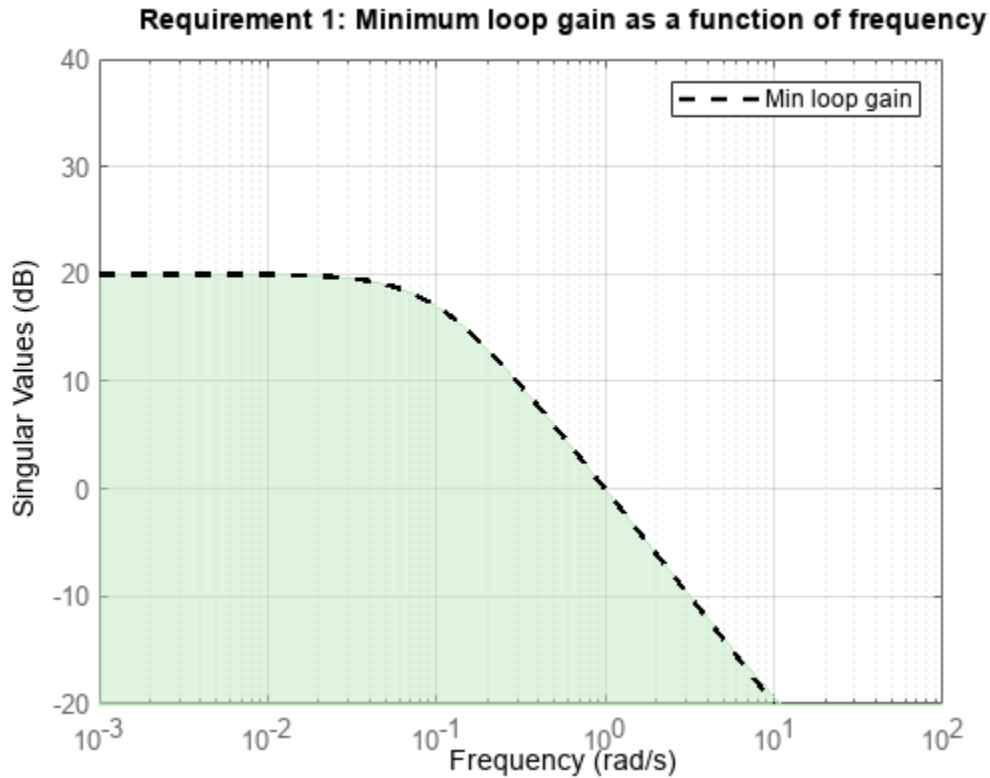

The dashed line shows the specified gain profile. The shaded region indicates where the tuning goal is violated, except that gain values less than 1 are not enforced. Therefore, this tuning goal only specifies a minimum gain at frequencies below 1 rad/s.

You can use Req as an input to `looptune` or `systemtune` when tuning the control system. Then use `viewGoal(Req, T)` to compare the tuned loop gain to the minimum gain specified in the tuning goal, where T represents the tuned control system.

Integral Minimum Gain Specified as Gain Value at Single Frequency

Create a tuning goal that specifies a minimum loop gain profile of the form $L = K / s$. The gain profile attains the value of -20 dB (0.01) at 100 rad/s.

```
Req = TuningGoal.MinLoopGain('X',100,0.01);
viewGoal(Req)
```

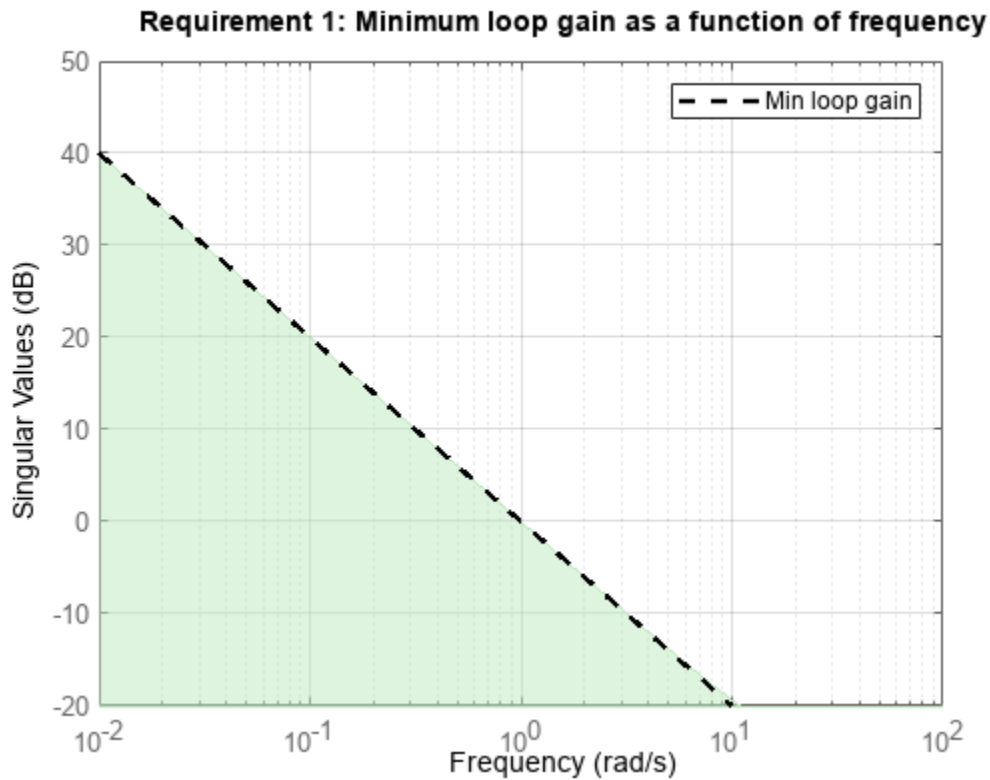

`viewGoal` confirms that the tuning goal is correctly specified. You can use this tuning goal to tune a control system that has a loop-opening location identified as 'X'. Since loop gain values less than 1 are ignored, this tuning goal specifies minimum gain only below 1 rad/s, with no restriction on loop gain at higher frequency.

Although the specified gain profile (dashed line) is a pure integrator, for numeric reasons, the gain profile enforced during tuning levels off at very low frequencies, as described in “Algorithms” on page 1-56. To see the regularized gain profile, expand the axes of the tuning-goal plot.

```
xlim([10^-4, 10^2])  
ylim([-20, 80])
```

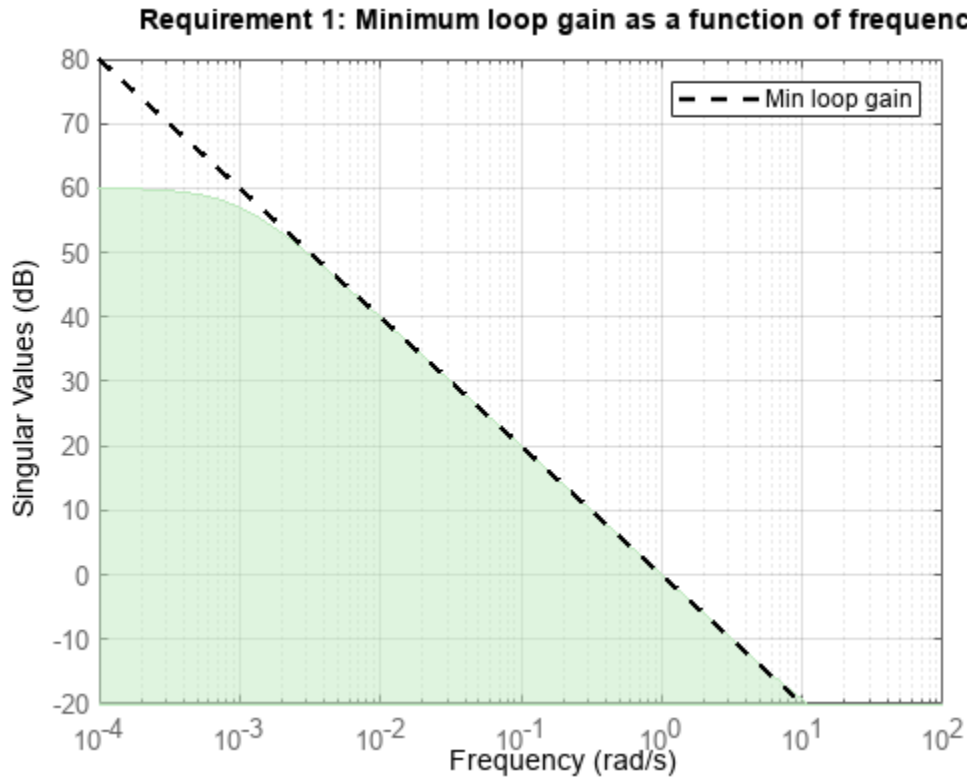

The shaded region reflects the modified gain profile.

Minimum Loop Gain as Constraint on Sensitivity Function

Examine a minimum loop gain tuning goal against the tuned loop gain. A minimum loop gain tuning goal is converted to a constraint on the gain of the sensitivity function at the location specified in the tuning goal.

To see this relationship between the minimum loop gain and the sensitivity function, tune the following closed-loop system with analysis points at X1 and X2. The control system has tunable PID controllers C1 and C2.

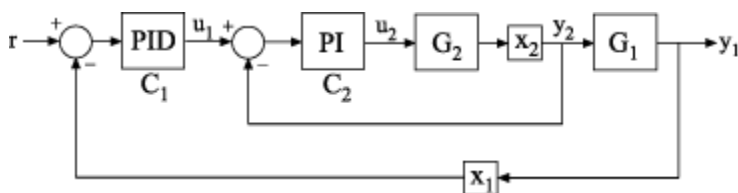

Create a model of the control system.

```
G2 = zpk([], -2, 3);
G1 = zpk([], [-1 -1 -1], 10);
C20 = tunablePID('C2', 'pi');
```

```

C10 = tunablePID('C1','pid');
X1 = AnalysisPoint('X1');
X2 = AnalysisPoint('X2');
InnerLoop = feedback(X2*G2*C20,1);
CL0 = feedback(G1*InnerLoop*C10,X1);
CL0.InputName = 'r';
CL0.OutputName = 'y';

```

Specify some tuning goals, including a minimum loop gain. Tune the control system to these requirements.

```

Rtrack = TuningGoal.Tracking('r','y',10,0.01);
Rreject = TuningGoal.Gain('X2','y',0.1);
Rgain = TuningGoal.MinLoopGain('X2',100,10000);
Rgain.Openings = 'X1';

```

```

opts = systuneOptions('RandomStart',2);
rng('default'); % for reproducibility
[CL,fSoft] = systune(CL0,[Rtrack,Rreject,Rgain]);

```

Final: Soft = 1.07, Hard = -Inf, Iterations = 101
 Some closed-loop poles are marginally stable (decay rate near 1e-07)

Examine the TuningGoal.MinLoopGain goal against the corresponding tuned response.

```
viewGoal(Rgain,CL)
```

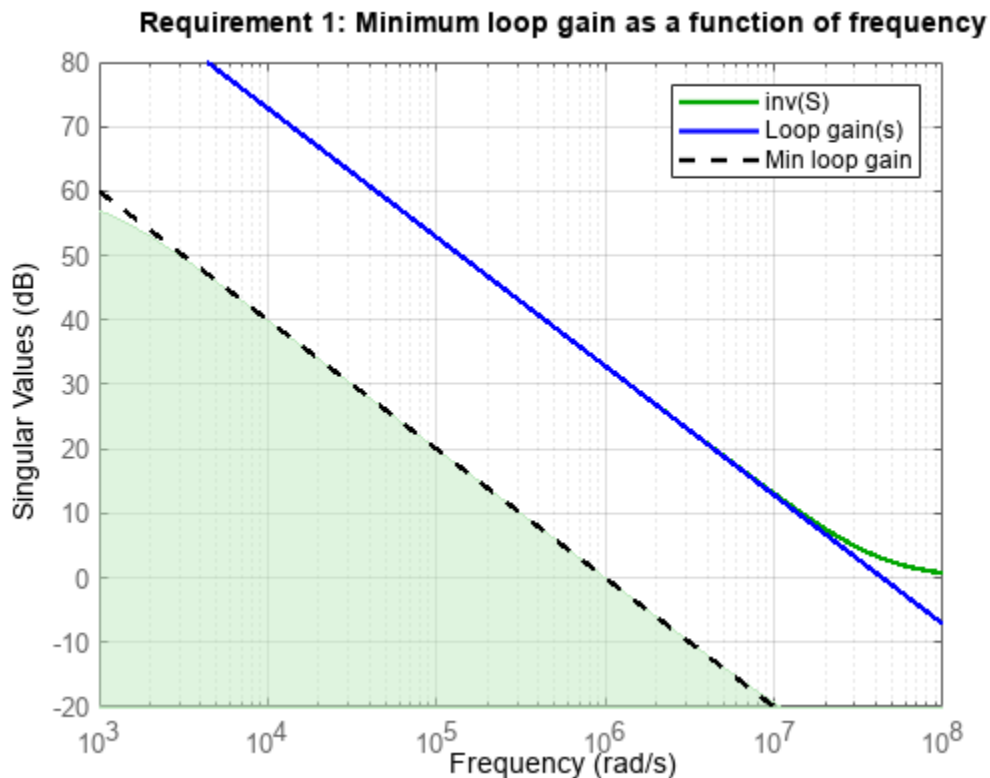

The plot shows the achieved loop gain for the loop at X2 (blue line). The plot also shows the inverse of the achieved sensitivity function, S , at the location X2 (green line). The inverse sensitivity function at this location is given by $\text{inv}(S) = I+L$. Here, L is the open-loop point-to-point loop transfer measured at X2.

The minimum loop gain goal R_{gain} is constraint on $\text{inv}(S)$, represented in the plot by the green shaded region. The constraint on $\text{inv}(S)$ can be thought of as a minimum gain constraint on L that applies where the gain of L (or the smallest singular value of L , for MIMO loops) is greater than 1.

Loop-Gain Requirement without Stability Constraint on Inner Loop

Create requirements that specify a minimum loop gain of 20 dB (100) at 50 rad/s and a maximum loop gain of -20 dB (0.01) at 1000 rad/s on the inner loop of the following control system.

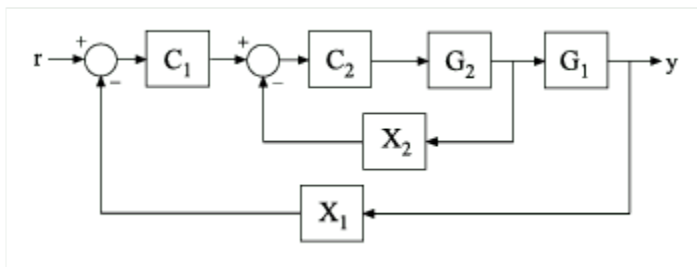

Create the maximum and minimum loop gain requirements.

```
RMinGain = TuningGoal.MinLoopGain('X2',50,100);
RMaxGain = TuningGoal.MaxLoopGain('X2',1000,0.01);
```

Configure the requirements to apply to the loop gain of the inner loop measured with the outer loop open.

```
RMinGain.Openings = 'X1';
RMaxGain.Openings = 'X1';
```

Setting `Req.Openings` tells the tuning algorithm to enforce the requirements with a loop open at the specified location. With the outer loop open, the requirements apply only to the inner loop.

By default, tuning using `TuningGoal.MinLoopGain` or `TuningGoal.MaxLoopGain` imposes a stability requirement as well as the minimum or maximum loop gain. Practically, in some control systems it is not possible to achieve a stable inner loop. In that case, remove the stability requirement for the inner loop by setting the `Stabilize` property to `false`.

```
RMinGain.Stabilize = false;
RMaxGain.Stabilize = false;
```

When you tune using either of these requirements, the tuning algorithm still imposes a stability requirement on the overall tuned control system, but not on the inner loop alone.

Tips

- This tuning goal imposes an implicit stability constraint on the closed-loop sensitivity function measured at `Location`, evaluated with loops opened at the points identified in `Openings`. The dynamics affected by this implicit constraint are the stabilized dynamics for this tuning goal. The `MinDecay` and `MaxRadius` options of `systuneOptions` control the bounds on these implicitly constrained dynamics. If the optimization fails to meet the default bounds, or if the default bounds conflict with other requirements, use `systuneOptions` to change these defaults.

Algorithms

When you tune a control system using a `TuningGoal`, the software converts the tuning goal into a normalized scalar value $f(x)$. Here, x is the vector of free (tunable) parameters in the control system. The software then adjusts the parameter values to minimize $f(x)$ or to drive $f(x)$ below 1 if the tuning goal is a hard constraint.

For `TuningGoal.MinLoopGain`, $f(x)$ is given by:

$$f(x) = \|W_S(D^{-1}SD)\|_{\infty}.$$

Here, D is a diagonal scaling (for MIMO loops). S is the sensitivity function at `Location`. W_S is a frequency-weighting function derived from the minimum loop gain profile, `MinGain`. The gain of this function roughly matches `MaxGain` for values ranging from -20 dB to 60 dB. For numerical reasons, the weighting function levels off outside this range, unless the specified gain profile changes slope outside this range. This adjustment is called regularization. Because poles of W_S close to $s = 0$ or $s = \text{Inf}$ might lead to poor numeric conditioning of the `systune` optimization problem, it is not recommended to specify gain profiles with very low-frequency or very high-frequency dynamics.

To obtain W_S , use:

```
WS = getWeight(Req,Ts)
```

where `Req` is the tuning goal, and `Ts` is the sample time at which you are tuning (`Ts = 0` for continuous time). For more information about regularization and its effects, see “Visualize Tuning Goals”.

Although S is a closed-loop transfer function, driving $f(x) < 1$ is equivalent to enforcing a lower bound on the open-loop transfer function, L , in a frequency band where the gain of L is greater than 1. To see why, note that $S = 1/(1 + L)$. For SISO loops, when $|L| \gg 1$, $|S| \approx 1/|L|$. Therefore, enforcing the open-loop minimum gain requirement, $|L| > |W_S|$, is roughly equivalent to enforcing $|W_S S| < 1$. For MIMO loops, similar reasoning applies, with $\|S\| \approx 1/\sigma_{\min}(L)$, where σ_{\min} is the smallest singular value.

For an example illustrating the constraint on S , see “Minimum Loop Gain as Constraint on Sensitivity Function” on page 1-53.

Version History

Introduced in R2016a

Functionality moved from Robust Control Toolbox

Behavior changed in R2016a

Prior to R2016a, this functionality required a Robust Control Toolbox license.

See Also

`looptune` | `sysstune` | `sysstune (for slTuner)` | `looptune (for slTuner)` | `viewGoal` | `evalGoal` | `TuningGoal.Gain` | `TuningGoal.LoopShape` | `TuningGoal.MaxLoopGain` | `TuningGoal.Margins` | `slTuner` | `sigma`

Topics

“Loop Shape and Stability Margin Specifications”

“Visualize Tuning Goals”

“PID Tuning for Setpoint Tracking vs. Disturbance Rejection”

TuningGoal.MaxLoopGain class

Package: TuningGoal

Maximum loop gain constraint for control system tuning

Description

Use `TuningGoal.MaxLoopGain` to enforce a maximum loop gain and desired roll-off in a particular frequency band. Use this tuning goal with control system tuning commands such as `systemtune` or `looptune`.

This tuning goal imposes a maximum gain on the open-loop frequency response (L) at a specified location in your control system. You specify the maximum open-loop gain as a function of frequency (a maximum gain profile). For MIMO feedback loops, the specified gain profile is interpreted as an upper bound on the largest singular value of L .

When you tune a control system, the maximum gain profile is converted to a maximum gain constraint on the complementary sensitivity function, $T) = L/(I + L)$.

The following figure shows a typical specified maximum gain profile (dashed line) and a resulting tuned loop gain, L (blue line). The shaded region represents gain profile values that are forbidden by this tuning goal. The figure shows that when L is much smaller than 1, imposing a maximum gain on T is a good proxy for a maximum open-loop gain.

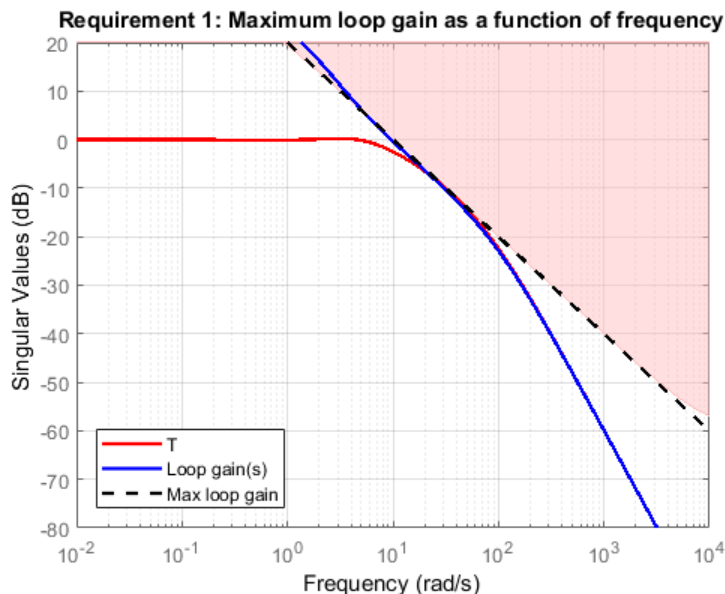

`TuningGoal.MaxLoopGain` and `TuningGoal.MinLoopGain` specify only high-gain or low-gain constraints in certain frequency bands. When you use these tuning goals, `systemtune` and `looptune` determine the best loop shape near crossover. When the loop shape near crossover is simple or well understood (such as integral action), you can use `TuningGoal.LoopShape` to specify that target loop shape.

Construction

`Req = TuningGoal.MaxLoopGain(location, loopgain)` creates a tuning goal for limiting the gain of a SISO or MIMO feedback loop. The tuning goal limits the open-loop frequency response measured at the specified locations to the maximum gain profile specified by `loopgain`. You can specify the maximum gain profile as a smooth transfer function or sketch a piecewise error profile using an `frd` model or the `makeweight` command. Only gain values smaller than 1 are enforced.

`Req = TuningGoal.MaxLoopGain(location, fmax, gmax)` specifies a maximum gain profile of the form $\text{loopgain} = K/s$ (integral action). The software chooses K such that the gain value is g_{max} at the specified frequency, f_{max} .

Input Arguments

location

Location at which the maximum open-loop gain is constrained, specified as a character vector or cell array of character vectors that identify one or more locations in the control system to tune. What loop-opening locations are available depends on what kind of system you are tuning:

- If you are tuning a Simulink model of a control system, you can use any linear analysis point marked in the model, or any linear analysis point in an `sLTuner` interface associated with the Simulink model. Use `addPoint` to add analysis points to the `sLTuner` interface. For example, if the `sLTuner` interface contains an analysis point `u`, you can use `'u'` to refer to that point when creating tuning goals. Use `getPoints` to get the list of analysis points available in an `sLTuner` interface to your model.
- If you are tuning a generalized state-space (`genss`) model of a control system, you can use any `AnalysisPoint` location in the control system model. For example, the following code creates a PI loop with an analysis point at the plant input `'u'`.

```
AP = AnalysisPoint('u');
G = tf(1,[1 2]);
C = tunablePID('C','pi');
T = feedback(G*AP*C,1);
```

When creating tuning goals, you can use `'u'` to refer to the analysis point at the plant input. Use `getPoints` to get the list of analysis points available in a `genss` model.

If `location` is a cell array of loop-opening locations, then the maximum gain requirement applies to the resulting MIMO loop.

loopgain

Maximum open-loop gain as a function of frequency.

You can specify `loopgain` as a smooth SISO transfer function (`tf`, `zpk`, or `ss` model). Alternatively, you can sketch a piecewise gain profile using a `frd` model or the `makeweight` command. For example, the following `frd` model specifies a maximum gain of 1 (0 dB) at 1 rad/s, rolling off at a rate of -20 dB/dec up to 10 rad/s, and a rate of -40 dB/dec at higher frequencies.

```
loopgain = frd([1 1e-1 1e-3],[1 10 100]);
bodemag(loopgain)
```

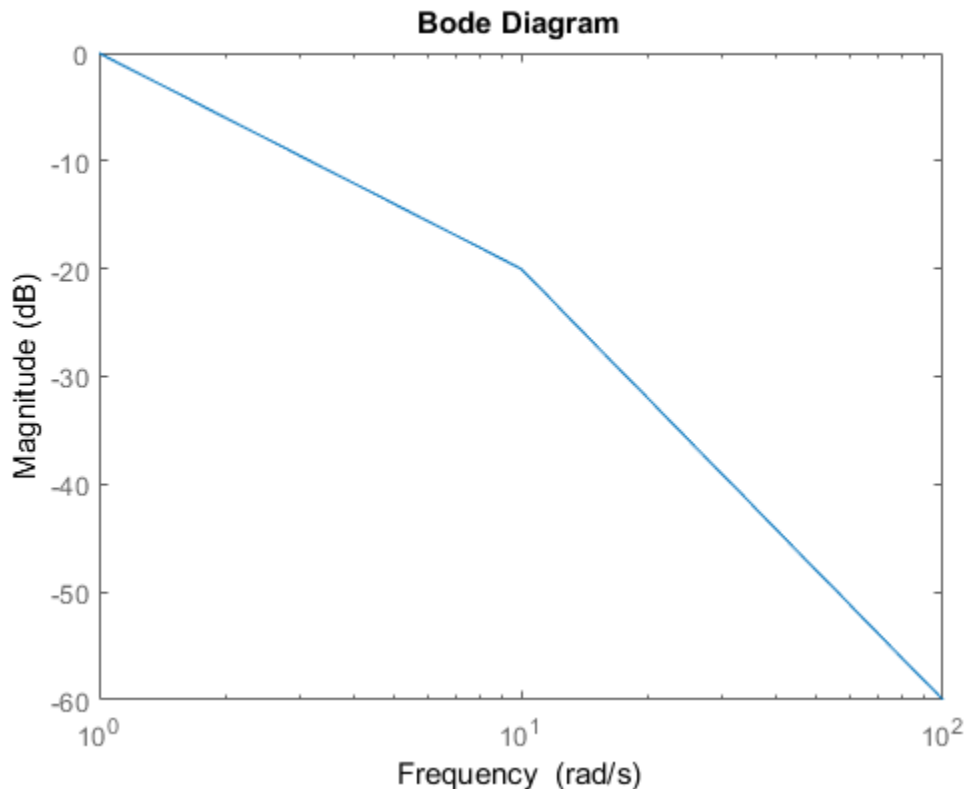

When you use an `frd` model to specify `loopgain`, the software automatically maps your specified gain profile to a `zpk` model. The magnitude of this model approximates the desired gain profile. Use `viewGoal(Req)` to plot the magnitude of that `zpk` model.

Only gain values smaller than 1 are enforced. For multi-input, multi-output (MIMO) feedback loops, the gain profile is interpreted as a minimum roll-off requirement, which is an upper bound on the largest singular value of L . For more information about singular values, see `sigma`.

If you are tuning in discrete time (that is, using a `genss` model or `sLTuner` interface with nonzero T_s), you can specify `loopgain` as a discrete-time model with the same T_s . If you specify `loopgain` in continuous time, the tuning software discretizes it. Specifying the loop gain in discrete time gives you more control over the loop gain near the Nyquist frequency.

fmax

Frequency of maximum gain `gmax`, specified as a scalar value in rad/s.

Use this argument to specify a maximum gain profile of the form `loopgain = K/s` (integral action). The software chooses K such that the gain value is `gmax` at the specified frequency, `fmax`.

gmax

Value of maximum gain occurring at `fmax`, specified as a scalar absolute value.

Use this argument to specify a maximum gain profile of the form `loopgain = K/s` (integral action). The software chooses K such that the gain value is `gmax` at the specified frequency, `fmax`.

Properties

MaxGain

Maximum open-loop gain as a function of frequency, specified as a SISO zpk model.

The software automatically maps the input argument `loopgain` onto a zpk model. The magnitude of this zpk model approximates the desired gain profile. Alternatively, if you use the `fmax` and `gmax` arguments to specify the gain profile, this property is set to `K/s`. The software chooses `K` such that the gain value is `gmax` at the specified frequency, `fmax`.

Use `viewGoal(Req)` to plot the magnitude of the open-loop maximum gain profile.

Focus

Frequency band in which tuning goal is enforced, specified as a row vector of the form `[min,max]`.

Set the `Focus` property to limit enforcement of the tuning goal to a particular frequency band. Express this value in the frequency units of the control system model you are tuning (`rad/TimeUnit`). For example, suppose `Req` is a tuning goal that you want to apply only between 1 and 100 rad/s. To restrict the tuning goal to this band, use the following command:

```
Req.Focus = [1,100];
```

Default: `[0,Inf]` for continuous time; `[0,pi/Ts]` for discrete time, where `Ts` is the model sample time.

Stabilize

Stability requirement on closed-loop dynamics, specified as 1 (`true`) or 0 (`false`).

When `Stabilize` is `true`, this requirement stabilizes the specified feedback loop, as well as imposing gain or loop-shape requirements. Set `Stabilize` to `false` if stability for the specified loop is not required or cannot be achieved.

Default: 1 (`true`)

LoopScaling

Toggle for automatically scaling loop signals, specified as `'on'` or `'off'`.

In multi-loop or MIMO control systems, the feedback channels are automatically rescaled to equalize the off-diagonal terms in the open-loop transfer function (loop interaction terms). Set `LoopScaling` to `'off'` to disable such scaling and shape the unscaled open-loop response.

Default: `'on'`

Location

Location at which minimum loop gain is constrained, specified as a cell array of character vectors that identify one or more analysis points in the control system to tune. For example, if `Location = {'u'}`, the tuning goal evaluates the open-loop response measured at an analysis point `'u'`. If `Location = {'u1','u2'}`, the tuning goal evaluates the MIMO open-loop response measured at analysis points `'u1'` and `'u2'`.

The value of the `Location` property is set by the `location` input argument when you create the tuning goal.

Models

Models to which the tuning goal applies, specified as a vector of indices.

Use the `Models` property when tuning an array of control system models with `systune`, to enforce a tuning goal for a subset of models in the array. For example, suppose you want to apply the tuning goal, `Req`, to the second, third, and fourth models in a model array passed to `systune`. To restrict enforcement of the tuning goal, use the following command:

```
Req.Models = 2:4;
```

When `Models = NaN`, the tuning goal applies to all models.

Default: NaN

Openings

Feedback loops to open when evaluating the tuning goal, specified as a cell array of character vectors that identify loop-opening locations. The tuning goal is evaluated against the open-loop configuration created by opening feedback loops at the locations you identify.

If you are using the tuning goal to tune a Simulink model of a control system, then `Openings` can include any linear analysis point marked in the model, or any linear analysis point in an `sITuner` interface associated with the Simulink model. Use `addPoint` to add analysis points and loop openings to the `sITuner` interface. Use `getPoints` to get the list of analysis points available in an `sITuner` interface to your model.

If you are using the tuning goal to tune a generalized state-space (`genss`) model of a control system, then `Openings` can include any `AnalysisPoint` location in the control system model. Use `getPoints` to get the list of analysis points available in the `genss` model.

For example, if `Openings = {'u1', 'u2'}`, then the tuning goal is evaluated with loops open at analysis points `u1` and `u2`.

Default: {}

Name

Name of the tuning goal, specified as a character vector.

For example, if `Req` is a tuning goal:

```
Req.Name = 'LoopReq';
```

Default: []

Examples

Maximum Loop Gain Tuning Goal

Create a tuning goal that limits the maximum open-loop gain of a feedback loop to a specified profile.

Suppose that you are tuning a control system that has a loop-opening location identified by `PILoop`. Limit the open-loop gain measured at that location to 1 (0 dB) at 1 rad/s, rolling off at a rate of -20 dB/dec up to 10 rad/s, and a rate of -40 dB/dec at higher frequencies. Use an `frd` model to sketch this gain profile.

```
loopgain = frd([1 1e-1 1e-3],[1 10 100]);
Req = TuningGoal.MaxLoopGain('PILoop',loopgain);
```

The software converts `loopgain` into a smooth function of frequency that approximates the piecewise-specified gain profile. Display the tuning goal using `viewGoal`.

```
viewGoal(Req)
```

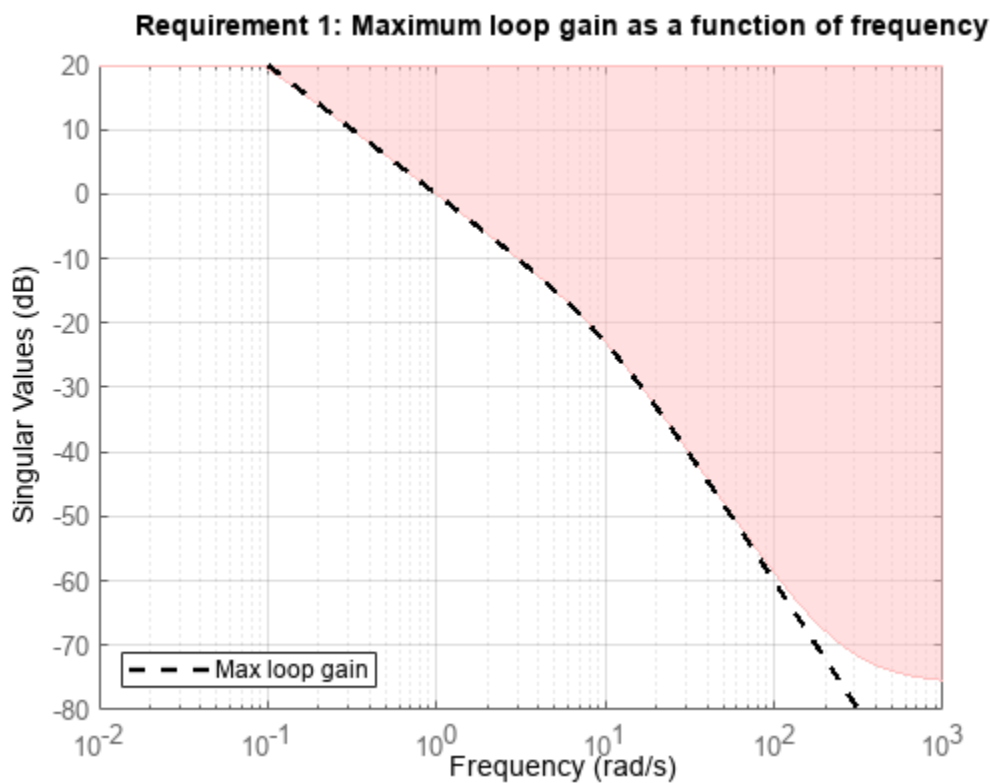

The dashed line shows the specified gain profile. The shaded region indicates where the tuning goal is violated, except that gain values greater than 1 are not enforced. Therefore, this tuning goal only specifies minimum roll-off rates at frequencies above 1 rad/s.

You can use `Req` as an input to `looptune` or `systune` when tuning the control system. Then use `viewGoal(Req,T)` to compare the tuned loop gain to the minimum gain specified in the tuning goal, where `T` represents the tuned control system.

Integral Maximum Gain Specified as Gain Value at Single Frequency

Create a tuning goal that specifies a maximum loop gain of the form $L = K / s$. The maximum gain attains the value of -20 dB (0.01) at 100 rad/s.

```
Req = TuningGoal.MaxLoopGain('X',100,0.01);
viewGoal(Req)
```

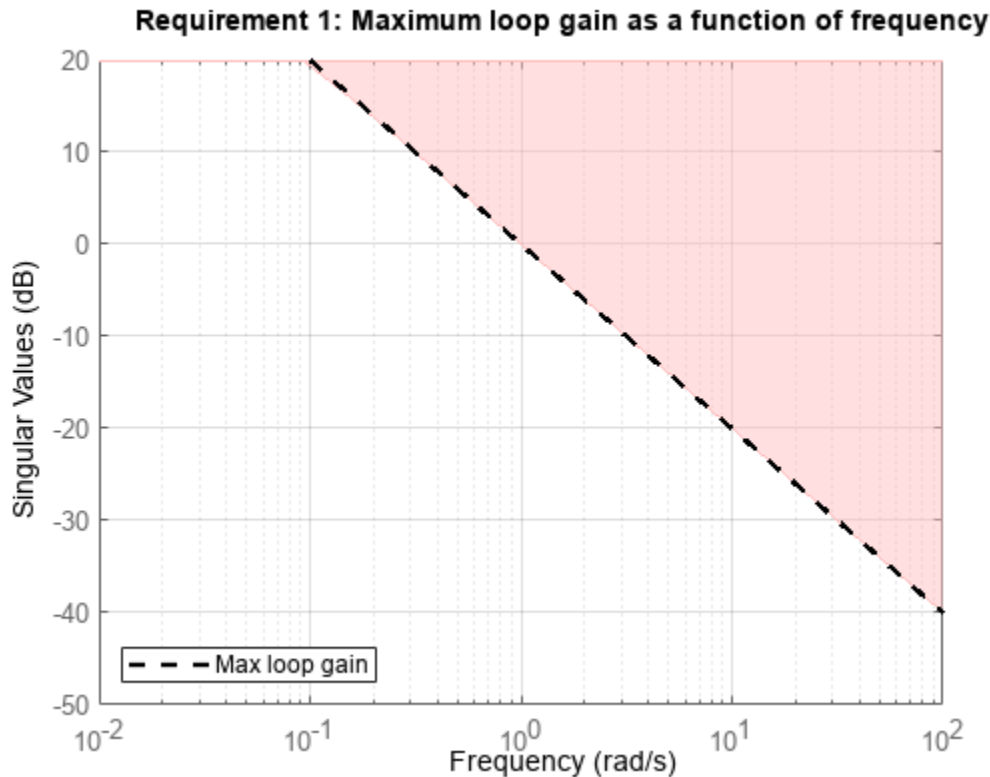

`viewGoal` confirms that the tuning goal is correctly specified. You can use this tuning goal to tune a control system that has a loop-opening location identified as 'X'. Since loop gain values greater than 1 are ignored, this requirement specifies a rolloff of 20 dB/decade above 1 rad/s, with no restriction on loop gain below that frequency.

Although the specified gain profile (dashed line) is a pure integrator, for numeric reasons, the gain profile enforced during tuning levels off at very high frequencies, as described in “Algorithms” on page 1-56. To see the regularized gain profile, expand the axes of the tuning-goal plot.

```
xlim([10^-2,10^4])
ylim([-80,20])
```

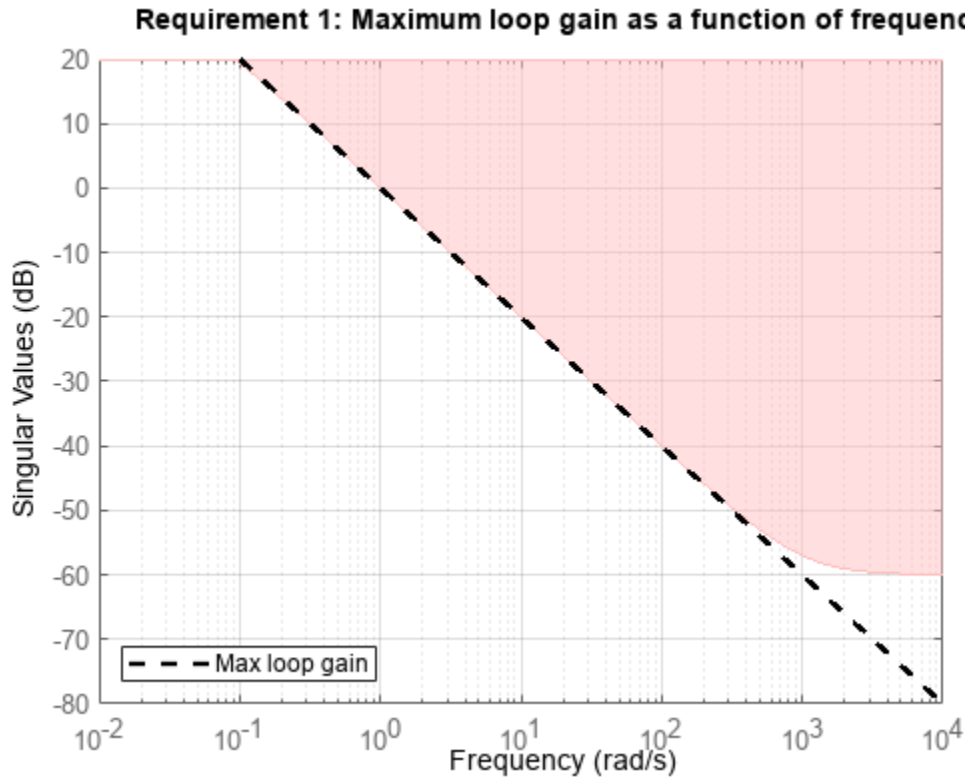

The shaded region reflects the modified gain profile.

Loop-Gain Requirement without Stability Constraint on Inner Loop

Create requirements that specify a minimum loop gain of 20 dB (100) at 50 rad/s and a maximum loop gain of -20 dB (0.01) at 1000 rad/s on the inner loop of the following control system.

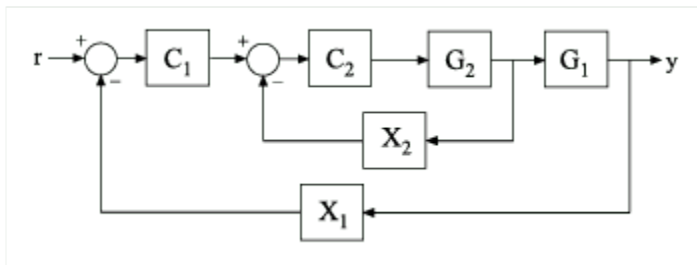

Create the maximum and minimum loop gain requirements.

```
RMinGain = TuningGoal.MinLoopGain('X2',50,100);
RMaxGain = TuningGoal.MaxLoopGain('X2',1000,0.01);
```

Configure the requirements to apply to the loop gain of the inner loop measured with the outer loop open.

```
RMinGain.Openings = 'X1';
RMaxGain.Openings = 'X1';
```

Setting `Req.Openings` tells the tuning algorithm to enforce the requirements with a loop open at the specified location. With the outer loop open, the requirements apply only to the inner loop.

By default, tuning using `TuningGoal.MinLoopGain` or `TuningGoal.MaxLoopGain` imposes a stability requirement as well as the minimum or maximum loop gain. Practically, in some control systems it is not possible to achieve a stable inner loop. In that case, remove the stability requirement for the inner loop by setting the `Stabilize` property to `false`.

```
RMinGain.Stabilize = false;
RMaxGain.Stabilize = false;
```

When you tune using either of these requirements, the tuning algorithm still imposes a stability requirement on the overall tuned control system, but not on the inner loop alone.

Tips

- This tuning goal imposes an implicit stability constraint on the closed-loop sensitivity function measured at `Location`, evaluated with loops opened at the points identified in `Openings`. The dynamics affected by this implicit constraint are the stabilized dynamics for this tuning goal. The `MinDecay` and `MaxRadius` options of `systuneOptions` control the bounds on these implicitly constrained dynamics. If the optimization fails to meet the default bounds, or if the default bounds conflict with other requirements, use `systuneOptions` to change these defaults.

Algorithms

When you tune a control system using a `TuningGoal`, the software converts the tuning goal into a normalized scalar value $f(x)$. Here, x is the vector of free (tunable) parameters in the control system. The software then adjusts the parameter values to minimize $f(x)$ or to drive $f(x)$ below 1 if the tuning goal is a hard constraint.

For `TuningGoal.MaxLoopGain`, $f(x)$ is given by:

$$f(x) = \left\| W_T (D^{-1} T D) \right\|_{\infty}.$$

Here, D is a diagonal scaling (for MIMO loops). T is the complementary sensitivity function at `Location`. W_T is a frequency-weighting function derived from the maximum loop gain profile, `MaxGain`. The gain of this function roughly matches $1/\text{MaxGain}$ for values ranging from -60 dB to 20 dB. For numerical reasons, the weighting function levels off outside this range, unless the specified gain profile changes slope outside this range. This adjustment is called regularization. Because poles of W_T close to $s = 0$ or $s = \text{Inf}$ might lead to poor numeric conditioning of the `systune` optimization problem, it is not recommended to specify gain profiles with very low-frequency or very high-frequency dynamics.

To obtain W_T , use:

```
WT = getWeight(Req, Ts)
```

where `Req` is the tuning goal, and `Ts` is the sample time at which you are tuning (`Ts = 0` for continuous time). For more information about regularization and its effects, see “Visualize Tuning Goals”.

Although T is a closed-loop transfer function, driving $f(x) < 1$ is equivalent to enforcing an upper bound on the open-loop transfer, L , in a frequency band where the gain of L is less than one. To see why, note that $T = L/(I + L)$. For SISO loops, when $|L| \ll 1$, $|T| \approx |L|$. Therefore, enforcing the open-loop maximum gain requirement, $|L| < 1/|W_T|$, is roughly equivalent to enforcing $|W_T T| < 1$. For MIMO loops, similar reasoning applies, with $\|T\| \approx \sigma_{\max}(L)$, where σ_{\max} is the largest singular value.

Version History

Introduced in R2016a

Functionality moved from Robust Control Toolbox

Behavior changed in R2016a

Prior to R2016a, this functionality required a Robust Control Toolbox license.

See Also

`looptune` | `system` | `looptune` (for `sITuner`) | `system` (for `sITuner`) | `viewGoal` | `evalGoal` | `TuningGoal.Gain` | `TuningGoal.LoopShape` | `TuningGoal.MinLoopGain` | `TuningGoal.Margins` | `sITuner` | `sigma`

Topics

“Loop Shape and Stability Margin Specifications”

“Visualize Tuning Goals”

“PID Tuning for Setpoint Tracking vs. Disturbance Rejection”

“MIMO Control of Diesel Engine”

“Tuning of a Two-Loop Autopilot”

TuningGoal.Overshoot class

Package: TuningGoal

Overshoot constraint for control system tuning

Description

Use `TuningGoal.Overshoot` to limit the overshoot in the step response from specified inputs to specified outputs of a control system. Use this tuning goal for control system tuning with tuning commands such as `systemtune` or `looptune`.

Construction

`Req = TuningGoal.Overshoot(inputname,outputname,maxpercent)` creates a tuning goal for limiting the overshoot in the step response between the specified signal locations. The scalar `maxpercent` specifies the maximum overshoot as a percentage.

When you use `TuningGoal.Overshoot` for tuning, the software maps overshoot constraints to peak gain constraints assuming second-order system characteristics. Therefore, the mapping is only approximate for higher-order systems. In addition, this tuning goal cannot reliably reduce the overshoot below 5%.

Input Arguments

inputname

Input signals for the tuning goal, specified as a character vector or, for multiple-input tuning goals, a cell array of character vectors.

- If you are using the tuning goal to tune a Simulink model of a control system, then `inputname` can include:
 - Any model input.
 - Any linear analysis point marked in the model.
 - Any linear analysis point in an `sITuner` interface associated with the Simulink model. Use `addPoint` to add analysis points to the `sITuner` interface. Use `getPoints` to get the list of analysis points available in an `sITuner` interface to your model.

For example, suppose that the `sITuner` interface contains analysis points `u1` and `u2`. Use `'u1'` to designate that point as an input signal when creating tuning goals. Use `{'u1','u2'}` to designate a two-channel input.

- If you are using the tuning goal to tune a generalized state-space (`genss`) model of a control system, then `inputname` can include:
 - Any input of the `genss` model
 - Any `AnalysisPoint` location in the control system model

For example, if you are tuning a control system model, `T`, then `inputname` can be any input name in `T.InputName`. Also, if `T` contains an `AnalysisPoint` block with a location named `AP_u`, then

`inputname` can include 'AP_u'. Use `getPoints` to get a list of analysis points available in a `genss` model.

If `inputname` is an `AnalysisPoint` location of a generalized model, the input signal for the tuning goal is the implied input associated with the `AnalysisPoint` block:



For more information about analysis points in control system models, see “Mark Signals of Interest for Control System Analysis and Design”.

outputname

Output signals for the tuning goal, specified as a character vector or, for multiple-output tuning goals, a cell array of character vectors.

- If you are using the tuning goal to tune a Simulink model of a control system, then `outputname` can include:
 - Any model output.
 - Any linear analysis point marked in the model.
 - Any linear analysis point in an `sITuner` interface associated with the Simulink model. Use `addPoint` to add analysis points to the `sITuner` interface. Use `getPoints` to get the list of analysis points available in an `sITuner` interface to your model.

For example, suppose that the `sITuner` interface contains analysis points `y1` and `y2`. Use 'y1' to designate that point as an output signal when creating tuning goals. Use {'y1', 'y2'} to designate a two-channel output.

- If you are using the tuning goal to tune a generalized state-space (`genss`) model of a control system, then `outputname` can include:
 - Any output of the `genss` model
 - Any `AnalysisPoint` location in the control system model

For example, if you are tuning a control system model, `T`, then `outputname` can be any output name in `T.OutputName`. Also, if `T` contains an `AnalysisPoint` block with a location named `AP_u`, then `outputname` can include 'AP_u'. Use `getPoints` to get a list of analysis points available in a `genss` model.

If `outputname` is an `AnalysisPoint` location of a generalized model, the output signal for the tuning goal is the implied output associated with the `AnalysisPoint` block:



For more information about analysis points in control system models, see “Mark Signals of Interest for Control System Analysis and Design”.

maxpercent

Maximum percent overshoot, specified as a scalar value. For example, the following code specifies a maximum 5% overshoot in the step response from 'r' to 'y'.

```
Req = TuningGoal.Overshoot('r','y',5);
```

`TuningGoal.OverShoot` cannot reliably reduce the overshoot below 5%.

Properties

MaxOvershoot

Maximum percent overshoot, specified as a scalar value. For example, the scalar value 5 means the overshoot should not exceed 5%. The initial value of the `MaxOvershoot` property is set by the `maxpercent` input argument when you construct the tuning goal.

InputScaling

Reference signal scaling, specified as a vector of positive real values.

For a MIMO tracking requirement, when the choice of units results in a mix of small and large signals in different channels of the response, use this property to specify the relative amplitude of each entry in the vector-valued step input. This information is used to scale the off-diagonal terms in the transfer function from reference to tracking error. This scaling ensures that cross-couplings are measured relative to the amplitude of each reference signal.

For example, suppose that `Req` is a tuning goal that signals { 'y1' , 'y2' } track reference signals { 'r1' , 'r2' }. Suppose further that you require the outputs to track the references with less than 10% cross-coupling. If `r1` and `r2` have comparable amplitudes, then it is sufficient to keep the gains from `r1` to `y2` and `r2` and `y1` below 0.1. However, if `r1` is 100 times larger than `r2`, the gain from `r1` to `y2` must be less than 0.001 to ensure that `r1` changes `y2` by less than 10% of the `r2` target. To ensure this result, set the `InputScaling` property as follows.

```
Req.InputScaling = [100,1];
```

This tells the software to take into account that the first reference signal is 100 times greater than the second reference signal.

The default value, `[]` , means no scaling.

Default: `[]`

Input

Input signal names, specified as a cell array of character vectors that identify the inputs of the transfer function that the tuning goal constrains. The initial value of the `Input` property is set by the `inputname` input argument when you construct the tuning goal.

Output

Output signal names, specified as a cell array of character vectors that identify the outputs of the transfer function that the tuning goal constrains. The initial value of the `Output` property is set by the `outputname` input argument when you construct the tuning goal.

Models

Models to which the tuning goal applies, specified as a vector of indices.

Use the `Models` property when tuning an array of control system models with `systemtune`, to enforce a tuning goal for a subset of models in the array. For example, suppose you want to apply the tuning goal, `Req`, to the second, third, and fourth models in a model array passed to `systemtune`. To restrict enforcement of the tuning goal, use the following command:

```
Req.Models = 2:4;
```

When `Models = NaN`, the tuning goal applies to all models.

Default: NaN**Openings**

Feedback loops to open when evaluating the tuning goal, specified as a cell array of character vectors that identify loop-opening locations. The tuning goal is evaluated against the open-loop configuration created by opening feedback loops at the locations you identify.

If you are using the tuning goal to tune a Simulink model of a control system, then `Openings` can include any linear analysis point marked in the model, or any linear analysis point in an `slTuner` interface associated with the Simulink model. Use `addPoint` to add analysis points and loop openings to the `slTuner` interface. Use `getPoints` to get the list of analysis points available in an `slTuner` interface to your model.

If you are using the tuning goal to tune a generalized state-space (`genss`) model of a control system, then `Openings` can include any `AnalysisPoint` location in the control system model. Use `getPoints` to get the list of analysis points available in the `genss` model.

For example, if `Openings = {'u1', 'u2'}`, then the tuning goal is evaluated with loops open at analysis points `u1` and `u2`.

Default: {}**Name**

Name of the tuning goal, specified as a character vector.

For example, if `Req` is a tuning goal:

```
Req.Name = 'LoopReq';
```

Default: []**Examples**

Overshoot Constraint

Create a tuning goal that limits the overshoot of the step response from signals named 'r' to 'y' in a control system to 10 percent.

```
Req = TuningGoal.Overshoot('r','y',10);
```

The overshoot tuning goal is evaluated as a constraint on the peak system gain, assuming second-order model characteristics (see “Algorithms” on page 1-73). Visualizing the tuning goal shows a shaded area where the target peak gain is exceeded.

```
viewGoal(Req)
```

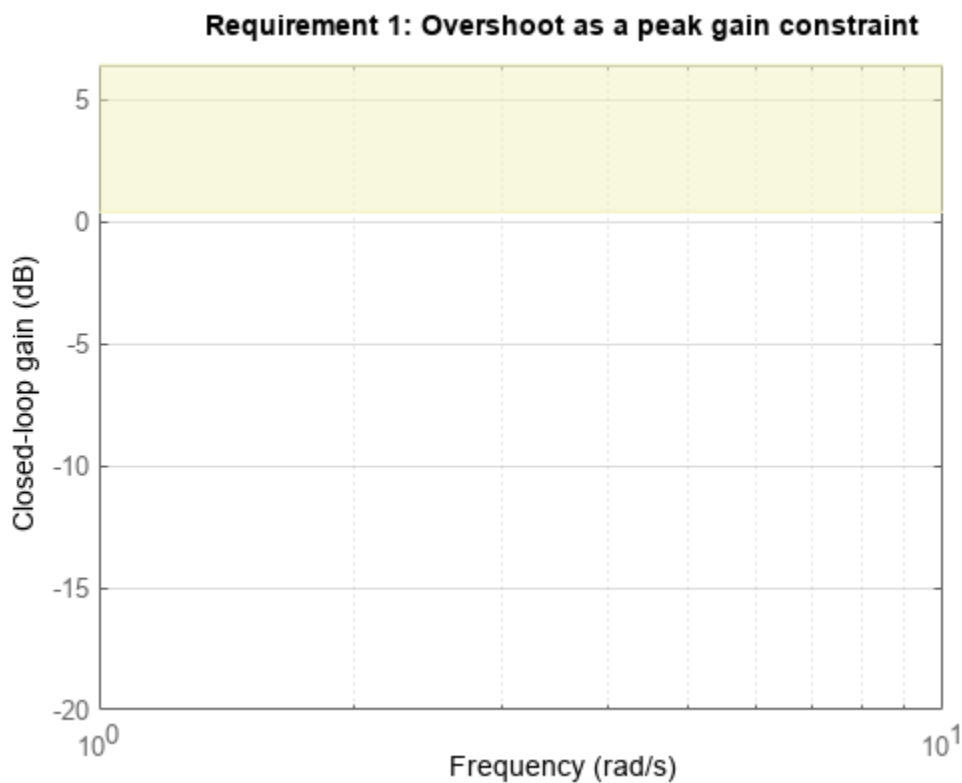

If you visualize the tuning goal with a tuned system, the plot includes the corresponding system response.

Configure other characteristics of the tuning goal by setting properties. For instance, configure the tuning goal to apply only to the second model in a model array to tune. Also, configure it to be evaluated with a loop open at an analysis point in the control system called OuterLoop.

```
Req.Models = 2;  
Req.Openings = 'OuterLoop';
```

Tips

- This tuning goal imposes an implicit stability constraint on the closed-loop transfer function from `Input` to `Output`, evaluated with loops opened at the points identified in `Openings`. The dynamics affected by this implicit constraint are the stabilized dynamics for this tuning goal. The `MinDecay` and `MaxRadius` options of `systuneOptions` control the bounds on these implicitly constrained dynamics. If the optimization fails to meet the default bounds, or if the default bounds conflict with other requirements, use `systuneOptions` to change these defaults.

Algorithms

When you tune a control system using a `TuningGoal`, the software converts the tuning goal into a normalized scalar value $f(x)$. x is the vector of free (tunable) parameters in the control system. The software then adjusts the parameter values to minimize $f(x)$, or to drive $f(x)$ below 1 if the tuning goal is a hard constraint.

For `TuningGoal.Overshoot`, $f(x)$ reflects the relative satisfaction or violation of the goal. The percent deviation from $f(x) = 1$ roughly corresponds to the percent deviation from the specified overshoot target. For example, $f(x) = 1.2$ means the actual overshoot exceeds the target by roughly 20%, and $f(x) = 0.8$ means the actual overshoot is about 20% less than the target.

`TuningGoal.Overshoot` uses $\|T\|_\infty$ as a proxy for the overshoot, based on second-order model characteristics. Here, T is the closed-loop transfer function that the tuning goal constrains. The overshoot is tuned in the range from 5% ($\|T\|_\infty = 1$) to 100% ($\|T\|_\infty$). `TuningGoal.Overshoot` is ineffective at forcing the overshoot below 5%.

Version History

Introduced in R2016a

Functionality moved from Robust Control Toolbox

Behavior changed in R2016a

Prior to R2016a, this functionality required a Robust Control Toolbox license.

See Also

`looptune` | `systune` | `systune` (for `sITuner`) | `looptune` (for `sITuner`) | `viewGoal` | `evalGoal` | `TuningGoal.Gain` | `TuningGoal.Sensitivity` | `sITuner`

Topics

“Time-Domain Specifications”

“Multi-Loop PI Control of a Robotic Arm”

TuningGoal.Passivity class

Package: TuningGoal

Passivity constraint for control system tuning

Description

A system is passive if all its I/O trajectories $(u(t),y(t))$ satisfy:

$$\int_0^T y(t)^T u(t) dt > 0,$$

for all $T > 0$. Equivalently, a system is passive if its frequency response is positive real, which means that for all $\omega > 0$,

$$G(j\omega) + G(j\omega)^H > 0$$

Use `TuningGoal.Passivity` to enforce passivity of the response between specified inputs and outputs, when using a control system tuning command such as `systemtune`. You can also use `TuningGoal.Passivity` to ensure a particular excess or shortage of passivity (see `getPassiveIndex`).

Construction

`Req = TuningGoal.Passivity(inputname, outputname)` creates a tuning goal for enforcing passivity of the response from the specified inputs to the specified outputs.

`Req = TuningGoal.Passivity(inputname, outputname, nu, rho)` creates a tuning goal for enforcing:

$$\int_0^T y(t)^T u(t) dt > \nu \int_0^T u(t)^T u(t) dt + \rho \int_0^T y(t)^T y(t) dt,$$

for all $T > 0$. This tuning goal enforces an excess of passivity at the inputs or outputs when $\nu > 0$ or $\rho > 0$, respectively. The tuning goal allows for a shortage of input passivity when $\nu < 0$. See `getPassiveIndex` for more information about these indices.

Input Arguments

inputname

Input signals for the tuning goal, specified as a character vector or, for multiple-input tuning goals, a cell array of character vectors.

- If you are using the tuning goal to tune a Simulink model of a control system, then `inputname` can include:
 - Any model input.
 - Any linear analysis point marked in the model.

- Any linear analysis point in an `sLTuner` interface associated with the Simulink model. Use `addPoint` to add analysis points to the `sLTuner` interface. Use `getPoints` to get the list of analysis points available in an `sLTuner` interface to your model.

For example, suppose that the `sLTuner` interface contains analysis points `u1` and `u2`. Use `'u1'` to designate that point as an input signal when creating tuning goals. Use `{'u1', 'u2'}` to designate a two-channel input.

- If you are using the tuning goal to tune a generalized state-space (`genss`) model of a control system, then `inputname` can include:
 - Any input of the `genss` model
 - Any `AnalysisPoint` location in the control system model

For example, if you are tuning a control system model, `T`, then `inputname` can be any input name in `T.InputName`. Also, if `T` contains an `AnalysisPoint` block with a location named `AP_u`, then `inputname` can include `'AP_u'`. Use `getPoints` to get a list of analysis points available in a `genss` model.

If `inputname` is an `AnalysisPoint` location of a generalized model, the input signal for the tuning goal is the implied input associated with the `AnalysisPoint` block:



For more information about analysis points in control system models, see “Mark Signals of Interest for Control System Analysis and Design”.

outputname

Output signals for the tuning goal, specified as a character vector or, for multiple-output tuning goals, a cell array of character vectors.

- If you are using the tuning goal to tune a Simulink model of a control system, then `outputname` can include:
 - Any model output.
 - Any linear analysis point marked in the model.
 - Any linear analysis point in an `sLTuner` interface associated with the Simulink model. Use `addPoint` to add analysis points to the `sLTuner` interface. Use `getPoints` to get the list of analysis points available in an `sLTuner` interface to your model.

For example, suppose that the `sLTuner` interface contains analysis points `y1` and `y2`. Use `'y1'` to designate that point as an output signal when creating tuning goals. Use `{'y1', 'y2'}` to designate a two-channel output.

- If you are using the tuning goal to tune a generalized state-space (`genss`) model of a control system, then `outputname` can include:
 - Any output of the `genss` model

- Any `AnalysisPoint` location in the control system model

For example, if you are tuning a control system model, `T`, then `outputname` can be any output name in `T.OutputName`. Also, if `T` contains an `AnalysisPoint` block with a location named `AP_u`, then `outputname` can include `'AP_u'`. Use `getPoints` to get a list of analysis points available in a `genss` model.

If `outputname` is an `AnalysisPoint` location of a generalized model, the output signal for the tuning goal is the implied output associated with the `AnalysisPoint` block:



For more information about analysis points in control system models, see “Mark Signals of Interest for Control System Analysis and Design”.

nu

Target passivity at the inputs listed in `inputname`, specified as a scalar value. The input passivity index is defined as the largest value of ν for which:

$$\int_0^T y(t)^T u(t) dt > \nu \int_0^T u(t)^T u(t) dt,$$

for all $T > 0$. Equivalently, `nu` is the largest ν for which:

$$G(j\omega) + G(j\omega)^H > 2\nu I$$

When you set a target `nu` in a `TuningGoal.Passivity` goal, the tuning software:

- Ensures that the specified response is input strictly passive when `nu > 0`. The magnitude of `nu` sets the required excess of passivity.
- Allows the response to be not input strictly passive when `nu < 0`. The magnitude of `nu` sets the permitted shortage of passivity.

Default: 0

rho

Target passivity at the outputs listed in `outputname`, specified as a scalar value. The output passivity index is defined as the largest value of ρ for which:

$$\int_0^T y(t)^T u(t) dt > \rho \int_0^T y(t)^T y(t) dt,$$

for all $T > 0$.

When you set a target `rho` in a `TuningGoal.Passivity` goal, the tuning software:

- Ensures that the specified response is output strictly passive when `rho > 0`. The magnitude of `rho` sets the required excess of passivity.

- Allows the response to be not output strictly passive when $\rho < 0$. The magnitude of ρ sets the permitted shortage of passivity.

Default: 0

Properties

IPX

Target passivity at the inputs, stored as a scalar value. This value specifies the required amount of passivity at the inputs listed in `inputname`. The initial value of this property is set by the input argument `nu` when you create the `TuningGoal.Passivity` goal.

Default: 0

OPX

Target passivity at the outputs, stored as a scalar value. This value specifies the required amount of passivity at the outputs listed in `outputname`. The initial value of this property is set by the input argument `rho` when you create the `TuningGoal.Passivity` goal.

Default: 0

Focus

Frequency band in which tuning goal is enforced, specified as a row vector of the form `[min,max]`.

Set the `Focus` property to limit enforcement of the tuning goal to a particular frequency band. Express this value in the frequency units of the control system model you are tuning (`rad/TimeUnit`). For example, suppose `Req` is a tuning goal that you want to apply only between 1 and 100 rad/s. To restrict the tuning goal to this band, use the following command:

```
Req.Focus = [1,100];
```

Default: `[0,Inf]` for continuous time; `[0,pi/Ts]` for discrete time, where `Ts` is the model sample time.

Input

Input signal names, specified as a cell array of character vectors. The input signal names specify the input locations for determining passivity, initially populated by the `inputname` argument.

Output

Output signal names, specified as a cell array of character vectors. The output signal names specify the output locations for determining passivity, initially populated by the `outputname` argument.

Models

Models to which the tuning goal applies, specified as a vector of indices.

Use the `Models` property when tuning an array of control system models with `systemtune`, to enforce a tuning goal for a subset of models in the array. For example, suppose you want to apply the tuning goal, `Req`, to the second, third, and fourth models in a model array passed to `systemtune`. To restrict enforcement of the tuning goal, use the following command:

```
Req.Models = 2:4;
```

When `Models = NaN`, the tuning goal applies to all models.

Default: NaN

Openings

Feedback loops to open when evaluating the tuning goal, specified as a cell array of character vectors that identify loop-opening locations. The tuning goal is evaluated against the open-loop configuration created by opening feedback loops at the locations you identify.

If you are using the tuning goal to tune a Simulink model of a control system, then `Openings` can include any linear analysis point marked in the model, or any linear analysis point in an `sLTuner` interface associated with the Simulink model. Use `addPoint` to add analysis points and loop openings to the `sLTuner` interface. Use `getPoints` to get the list of analysis points available in an `sLTuner` interface to your model.

If you are using the tuning goal to tune a generalized state-space (`genss`) model of a control system, then `Openings` can include any `AnalysisPoint` location in the control system model. Use `getPoints` to get the list of analysis points available in the `genss` model.

For example, if `Openings = {'u1', 'u2'}`, then the tuning goal is evaluated with loops open at analysis points `u1` and `u2`.

Default: {}

Name

Name of the tuning goal, specified as a character vector.

For example, if `Req` is a tuning goal:

```
Req.Name = 'LoopReq';
```

Default: []

Examples

Passivity Requirement

Create a requirement that ensures passivity in the response from an input or analysis point `'u'` to an output or analysis point `'y'` in a control system.

```
TG = TuningGoal.Passivity('u', 'y');
```

Use `viewGoal` to visualize the tuning goal.

```
viewGoal(TG)
```

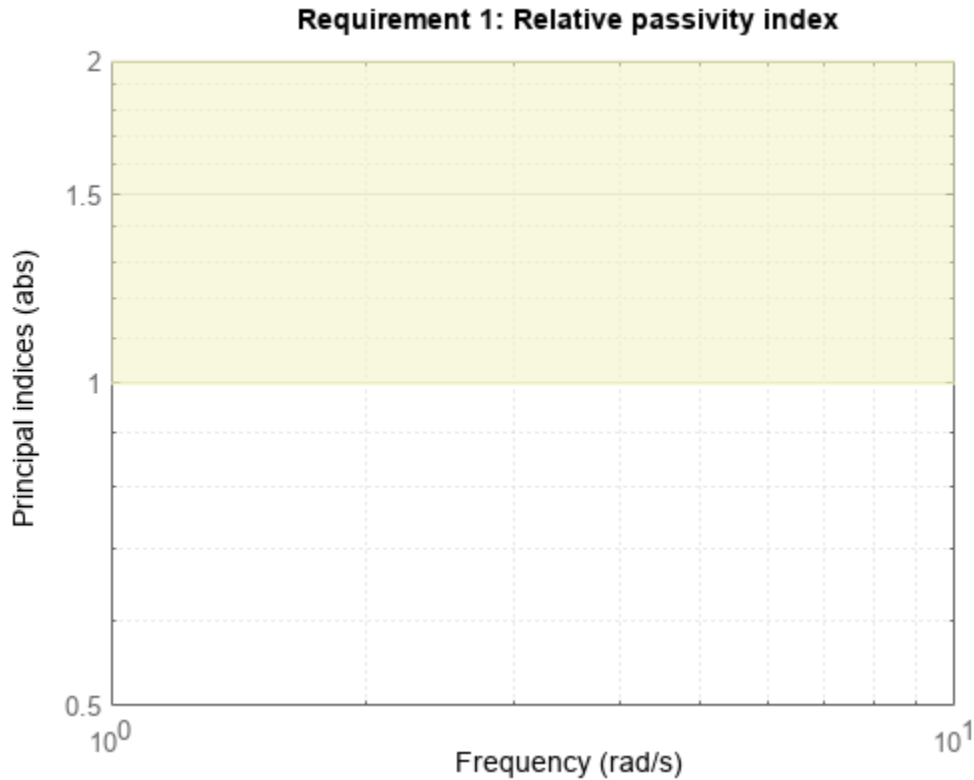
The requirement is satisfied when the relative passivity index $R < 1$ at all frequencies. The shaded area represents the region where the requirement is violated. When you use this requirement to tune a control system CL, `viewGoal(TG, CL)` shows R for the specified inputs and outputs on this plot, enabling you to identify frequency ranges in which the passivity requirement is violated.

Input Passivity in Specified Frequency Range

Create a requirement that ensures that the response from an input 'u' to an output 'y' is input strictly passive, with an excess of passivity of 2.

```
TGi = TuningGoal.Passivity('u', 'y', 2, 0);
```

Restrict the requirement to apply only within the frequency range between 0 and 10 rad/s.

```
TGi.Focus = [0 10];
```

Tips

- Use `viewGoal` to visualize this tuning goal. For enforcing passivity with $\nu_u = 0$ and $\rho = 0$, `viewGoal` plots the relative passivity indices as a function of frequency (see `passiveplot`). These are the singular values of $(I - G(j\omega))(I - G(j\omega))^{-1}$. The transfer function G from inputname to outputname (evaluated with loops open as specified in `Openings`) is passive when the largest singular value is less than 1 at all frequencies.

For nonzero ν or ρ , `viewGoal` plots the relative index as described in “Algorithms” on page 1-80.

- This tuning goal imposes an implicit minimum-phase constraint on the transfer function $G + I$. The transmission zeros of $G + I$ are the stabilized dynamics for this tuning goal. The `MinDecay` and `MaxRadius` options of `systuneOptions` control the bounds on these implicitly constrained dynamics. If the optimization fails to meet the default bounds, or if the default bounds conflict with other requirements, use `systuneOptions` to change these defaults.

Algorithms

When you tune a control system using a `TuningGoal`, the software converts the tuning goal into a normalized scalar value $f(x)$, where x is the vector of free (tunable) parameters in the control system. The software then adjusts the parameter values to minimize $f(x)$ or to drive $f(x)$ below 1 if the tuning goal is a hard constraint.

For the `TuningGoal.Passivity` goal, for a closed-loop transfer function $G(s, x)$ from `inputname` to `outputname`, $f(x)$ is given by:

$$f(x) = \frac{R}{1 + R/R_{\max}}, \quad R_{\max} = 10^6.$$

R is the relative sector index (see `getSectorIndex`) of $[G(s, x); I]$, for the sector represented by:

$$Q = \begin{pmatrix} 2\rho & -I \\ -I & 2\nu \end{pmatrix},$$

using the values of the `OPX` and `IPX` properties for ρ and ν , respectively.

Version History

Introduced in R2016a

See Also

`looptune` | `systune` | `systune` (for `slTuner`) | `looptune` (for `slTuner`) | `viewGoal` | `evalGoal` | `TuningGoal.WeightedPassivity` | `slTuner` | `getPassiveIndex` | `passiveplot`

Topics

“About Passivity and Passivity Indices”
 “Tune Control Systems with SYSTUNE”

TuningGoal.Poles class

Package: TuningGoal

Constraint on control system dynamics

Description

Use `TuningGoal.Poles` to constrain the closed-loop dynamics of a control system or of specific feedback loops within the control system. You can use this tuning goal for control system tuning with tuning commands, such as `systune` or `looptune`. A `TuningGoal.Poles` goal can ensure a minimum decay rate or minimum damping of the poles of the control system or loop. It can also eliminate fast dynamics in the tuned system.

Construction

`Req = TuningGoal.Poles(mindecay, mindamping, maxfreq)` creates a default template for constraining the closed-loop pole locations. The minimum decay rate, minimum damping constant, and maximum natural frequency define a region of the complex plane in which poles of the component must lie. Set `mindecay = 0`, `mindamping = 0`, or `maxfreq = Inf` to skip any of the three constraints.

`Req = TuningGoal.Poles(location, mindecay, mindamping, maxfreq)` constrains the poles of the sensitivity function measured at a specified location in the control system. (See `getSensitivity` for information about sensitivity functions.) Use this syntax to narrow the scope of the tuning goal to a particular feedback loop.

If you want to constrain the poles of the system with one or more feedback loops opened, set the `Openings` property. To limit the enforcement of this tuning goal to poles having natural frequency within a specified frequency range, set the `Focus` property. (See “Properties” on page 1-82.)

Input Arguments

mindecay

Minimum decay rate of poles of tunable component, specified as a nonnegative scalar value in the frequency units of the control system model you are tuning.

When you tune the control system using this tuning goal, the closed-loop poles of the control system are constrained to satisfy:

- $\text{Re}(s) < -\text{mindecay}$, for continuous-time systems.
- $\log(|z|) < -\text{mindecay} \cdot T_s$, for discrete-time systems with sample time T_s .

Set `mindecay = 0` to impose no constraint on the decay rate.

mindamping

Desired minimum damping ratio of the closed-loop poles, specified as a value between 0 and 1.

Poles that depend on the tunable parameters are constrained to satisfy $\text{Re}(s) < -\text{mindamping} * |s|$. In discrete time, the damping ratio is computed using $s = \log(z) / T_s$.

Set `mindamping = 0` to impose no constraint on the damping ratio.

maxfreq

Desired maximum natural frequency of closed-loop poles, specified as a scalar value in the frequency units of the control system model you are tuning.

Poles are constrained to satisfy $|s| < \text{maxfreq}$ for continuous time, or $|\log(z)| < \text{maxfreq} * T_s$ for discrete-time systems with sample time T_s . This constraint prevents fast dynamics in the closed-loop system.

Set `maxfreq = Inf` to impose no constraint on the natural frequency.

location

Location at which poles are assessed, specified as a character vector or cell array of character vectors that identify one or more locations in the control system to tune. When you use this input, the tuning goal constrains the poles of the sensitivity function measured at this location. (See `getSensitivity` for information about sensitivity functions.) What locations are available depends on what kind of system you are tuning:

- If you are tuning a Simulink model of a control system, you can use any linear analysis point marked in the model, or any linear analysis point in an `sLTuner` interface associated with the Simulink model. Use `addPoint` to add analysis points to the `sLTuner` interface. For example, if the `sLTuner` interface contains an analysis point `u`, you can use `'u'` to refer to that point when creating tuning goals. Use `getPoints` to get the list of analysis points available in an `sLTuner` interface to your model.
- If you are tuning a generalized state-space (`genss`) model of a control system, you can use any `AnalysisPoint` location in the control system model. For example, the following code creates a PI loop with an analysis point at the plant input `'u'`.

```
AP = AnalysisPoint('u');
G = tf(1,[1 2]);
C = tunablePID('C','pi');
T = feedback(G*AP*C,1);
```

When creating tuning goals, you can use `'u'` to refer to the analysis point at the plant input. Use `getPoints` to get the list of analysis points available in a `genss` model.

If `location` specifies multiple locations, then the poles constraint applies to the sensitivity of the MIMO loop.

Properties

MinDecay

Minimum decay rate of closed-loop poles of tunable component, specified as a positive scalar value in the frequency units of the control system you are tuning. The initial value of this property is set by the `mindecay` input argument.

When you tune the control system using this tuning goal, closed-loop poles are constrained to satisfy $\text{Re}(s) < -\text{MinDecay}$ for continuous-time systems, or $\log(|z|) < -\text{MinDecay} \cdot T_s$ for discrete-time systems with sample time T_s .

You can use dot notation to change the value of this property after you create the tuning goal. For example, suppose `Req` is a `TuningGoal.Poles` tuning goal. Change the minimum decay rate to 0.001:

```
Req.MinDecay = 0.001;
```

Default: 0

MinDamping

Desired minimum damping ratio of closed-loop poles, specified as a value between 0 and 1. The initial value of this property is set by the `mindamping` input argument.

Poles that depend on the tunable parameters are constrained to satisfy $\text{Re}(s) < -\text{MinDamping} \cdot |s|$. In discrete time, the damping ratio is computed using $s = \log(z)/T_s$.

Default: 0

MaxFrequency

Desired maximum natural frequency of closed-poles, specified as a scalar value in the frequency units of the control system model you are tuning. The initial value of this property is set by the `maxfreq` input argument.

Poles of the block are constrained to satisfy $|s| < \text{maxfreq}$ for continuous-time systems, or $|\log(z)| < \text{maxfreq} \cdot T_s$ for discrete-time systems with sample time T_s . This constraint prevents fast dynamics in the tuned control system.

You can use dot notation to change the value of this property after you create the tuning goal. For example, suppose `Req` is a `TuningGoal.ControllerPoles` tuning goal. Change the maximum frequency to 1000:

```
Req.MaxFrequency = 1000;
```

Default: Inf

Focus

Frequency band in which tuning goal is enforced, specified as a row vector of the form `[min, max]`.

Set the `Focus` property to limit enforcement of the tuning goal to a particular frequency band. Express this value in the frequency units of the control system model you are tuning (rad/TimeUnit). For example, suppose `Req` is a tuning goal that you want to apply only between 1 and 100 rad/s. To restrict the tuning goal to this band, use the following command:

```
Req.Focus = [1, 100];
```

Default: `[0, Inf]` for continuous time; `[0, pi/Ts]` for discrete time, where T_s is the model sample time.

Location

Location at which poles are assessed, specified as a cell array of character vectors that identify one or more analysis points in the control system to tune. For example, if `Location = {'u'}`, the tuning goal evaluates the open-loop response measured at an analysis point 'u'. If `Location = {'u1', 'u2'}`, the tuning goal evaluates the MIMO open-loop response measured at analysis points 'u1' and 'u2'.

The initial value of the `Location` property is set by the `location` input argument when you create the tuning goal.

Models

Models to which the tuning goal applies, specified as a vector of indices.

Use the `Models` property when tuning an array of control system models with `systemtune`, to enforce a tuning goal for a subset of models in the array. For example, suppose you want to apply the tuning goal, `Req`, to the second, third, and fourth models in a model array passed to `systemtune`. To restrict enforcement of the tuning goal, use the following command:

```
Req.Models = 2:4;
```

When `Models = NaN`, the tuning goal applies to all models.

Default: NaN

Openings

Feedback loops to open when evaluating the tuning goal, specified as a cell array of character vectors that identify loop-opening locations. The tuning goal is evaluated against the open-loop configuration created by opening feedback loops at the locations you identify.

If you are using the tuning goal to tune a Simulink model of a control system, then `Openings` can include any linear analysis point marked in the model, or any linear analysis point in an `sITuner` interface associated with the Simulink model. Use `addPoint` to add analysis points and loop openings to the `sITuner` interface. Use `getPoints` to get the list of analysis points available in an `sITuner` interface to your model.

If you are using the tuning goal to tune a generalized state-space (`genss`) model of a control system, then `Openings` can include any `AnalysisPoint` location in the control system model. Use `getPoints` to get the list of analysis points available in the `genss` model.

For example, if `Openings = {'u1', 'u2'}`, then the tuning goal is evaluated with loops open at analysis points `u1` and `u2`.

Default: {}

Name

Name of the tuning goal, specified as a character vector.

For example, if `Req` is a tuning goal:

```
Req.Name = 'LoopReq';
```

Default: []

Examples

Constrain Closed-Loop Dynamics of Specified Loop of System to Tune

Create a requirement that constrains the inner loop of the following control system to be stable and free of fast dynamics. Specify that the constraint is evaluated with the outer loop open.

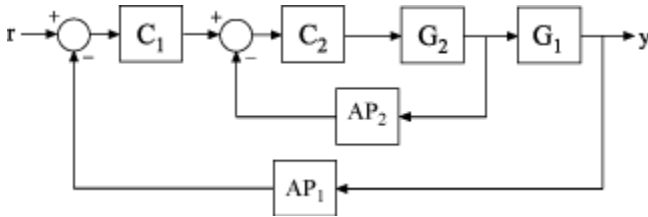

Create a model of the system. To do so, specify and connect the numeric plant models, G1 and G2, and the tunable controllers C1 and C2. Also, create and connect the AnalysisPoint blocks, AP1 and AP2, which mark points of interest for analysis and tuning.

```
G1 = tf(10,[1 10]);
G2 = tf([1 2],[1 0.2 10]);
C1 = tunablePID('C','pi');
C2 = tunableGain('G',1);
AP1 = AnalysisPoint('AP1');
AP2 = AnalysisPoint('AP2');
T = feedback(G1*feedback(G2*C2,AP2)*C1,AP1);
```

Create a tuning requirement that constrains the dynamics of the closed-loop poles. Restrict the poles of the inner loop to the region $\text{Re}(s) < -0.1$, $|s| < 30$.

```
Req = TuningGoal.Poles(0.1,0,30);
```

Setting the minimum damping to zero imposes no constraint on the damping constants for the poles.

Specify that the constraint on the tuned system poles is applied with the outer loop open.

```
Req.Openings = 'AP1';
```

When you tune T using this requirement, the constraint applies to the poles of the entire control system evaluated with the loop open at 'AP1'. In other words, the poles of the inner loop plus the poles of C1 and G1 are all considered.

After you tune T, you can use `viewGoal` to validate the tuned control system against the requirement.

Constrain Dynamics of Specified Feedback Loop

Create a requirement that constrains the inner loop of the system of the previous example to be stable and free of fast dynamics. Specify that the constraint is evaluated with the outer loop open.

Create a tuning requirement that constrains the dynamics of the inner feedback loop, the loop identified by AP2. Restrict the poles of the inner loop to the region $\text{Re}(s) < -0.1$, $|s| < 30$.

```
Req = TuningGoal.Poles('AP2',0.1,0,30);
```

Specify that the constraint on the tuned system poles is applied with the outer loop open.

```
Req.Openings = 'AP1';
```

When you tune T using this requirement, the constraint applies only to the poles of the inner loop, evaluated with the outer loop open. In this case, since G1 and C1 do not contribute to the sensitivity function at AP2 when the outer loop is open, the requirement constrains only the poles of G2 and C2.

After you tune T, you can use `viewGoal` to validate the tuned control system against the requirement.

Tips

- `TuningGoal.Poles` restricts the closed-loop dynamics of the tuned control system. To constrain the dynamics or ensure the stability of a single tunable component, use `TuningGoal.ControllerPoles`.

Algorithms

When you tune a control system using a `TuningGoal`, the software converts the tuning goal into a normalized scalar value $f(x)$. x is the vector of free (tunable) parameters in the control system. The software then adjusts the parameter values to minimize $f(x)$, or to drive $f(x)$ below 1 if the tuning goal is a hard constraint.

For `TuningGoal.Poles`, $f(x)$ reflects the relative satisfaction or violation of the goal. For example, if you attempt to constrain the closed-loop poles of a feedback loop to a minimum damping of $\zeta = 0.5$, then:

- $f(x) = 1$ means the smallest damping among the constrained poles is $\zeta = 0.5$ exactly.
- $f(x) = 1.1$ means the smallest damping $\zeta = 0.5/1.1 = 0.45$, roughly 10% less than the target.
- $f(x) = 0.9$ means the smallest damping $\zeta = 0.5/0.9 = 0.55$, roughly 10% better than the target.

Version History

Introduced in R2016a

Functionality moved from Robust Control Toolbox

Behavior changed in R2016a

Prior to R2016a, this functionality required a Robust Control Toolbox license.

See Also

`looptune` | `system` | `looptune` (for `sITuner`) | `system` (for `sITuner`) | `viewGoal` | `evalGoal` | `tunableTF` | `tunableSS` | `TuningGoal.ControllerPoles`

Topics

“System Dynamics Specifications”

“Digital Control of Power Stage Voltage”

“Multiloop Control of a Helicopter”

TuningGoal.Rejection class

Package: TuningGoal

Disturbance rejection requirement for control system tuning

Description

Use `TuningGoal.Rejection` to specify the minimum attenuation of a disturbance injected at a specified location in a control system. This tuning goal helps you tune control systems with tuning commands such as `systune` or `looptune`.

When you use `TuningGoal.Rejection`, the software attempts to tune the system so that the attenuation of a disturbance at the specified location exceeds the minimum attenuation factor you specify. This attenuation factor is the ratio between the open- and closed-loop sensitivities to the disturbance and is a function of frequency. You can achieve disturbance attenuation only inside the control bandwidth. The loop gain must be larger than one for the disturbance to be attenuated (attenuation factor > 1).

Construction

`Req = TuningGoal.Rejection(distloc,attfact)` creates a tuning goal for rejecting a disturbance entering at `distloc`. This tuning goal constrains the minimum disturbance attenuation factor to the frequency-dependent value, `attfact`.

Input Arguments

`distloc`

Disturbance location, specified as a character vector or, for multiple-input tuning goals, a cell array of character vectors.

- If you are using the tuning goal to tune a Simulink model of a control system, then `distloc` can include any signal identified as an analysis point in an `sITuner` interface associated with the Simulink model. Use `addPoint` to add analysis points to the `sITuner` interface. Use `getPoints` to get the list of analysis points available in an `sITuner` interface to your model.

For example, suppose that the `sITuner` interface contains analysis points `u1` and `u2`. Use `'u1'` to designate that point as the disturbance input when creating tuning goals. Use `{'u1','u2'}` to designate a two-channel disturbance input.

- If you are using the tuning goal to tune a generalized state-space model (`genss`) of a control system, then `inputname` can include any `AnalysisPoint` channel in the model. For example, if you are tuning a control system model, `T`, which contains an `AnalysisPoint` block with a location named `AP_u`, then `distloc` can include `'AP_u'`. (Use `getPoints` to get a list of analysis points available in a `genss` model.) The constrained disturbance location is injected at the implied input associated with the analysis point, and measured at the implied output:



attfact

Attenuation factor as a function of frequency, specified as a numeric LTI model.

`TuningGoal.Rejection` constrains the minimum disturbance attenuation to the frequency-dependent value `attfact`. You can specify `attfact` as a smooth transfer function (`tf`, `zpk`, or `ss` model). Alternatively, you can specify a piecewise gain profile using a `frd` model. For example, the following code specifies an attenuation factor of 100 (40 dB) below 1 rad/s, gradually dropping to 1 (0 dB) past 10 rad/s, for a disturbance injected at `u`.

```
attfact = frd([100 100 1 1],[0 1 10 100]);
Req = TuningGoal.Rejection('u',attfact);
bodemag(attfact)
ylim([-5,40])
```

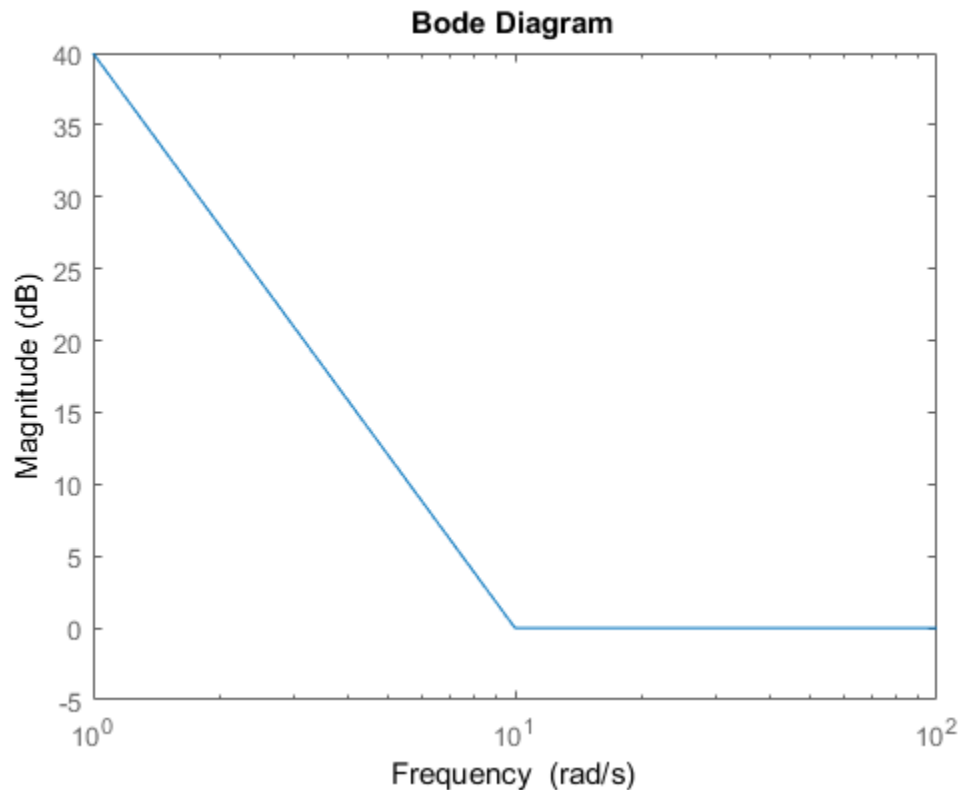

When you use an `frd` model to specify `attfact`, the gain profile is automatically mapped onto a `zpk` model. The magnitude of this `zpk` model approximates the desired gain profile. Use `viewGoal(Req)` to visualize the resulting attenuation profile.

If you are tuning in discrete time (that is, using a `genss` model or `sLTuner` interface with nonzero `Ts`), you can specify `attfact` as a discrete-time model with the same `Ts`. If you specify `attfact` in continuous time, the tuning software discretizes it. Specifying the attenuation profile in discrete time gives you more control over the profile near the Nyquist frequency.

Properties

MinAttenuation

Minimum disturbance attenuation as a function of frequency, expressed as a SISO zpk model.

The software automatically maps the `attfact` input argument to a zpk model. The magnitude of this zpk model approximates the desired attenuation factor and is stored in the `MinAttenuation` property. Use `viewGoal(Req)` to plot the magnitude of `MinAttenuation`.

Focus

Frequency band in which tuning goal is enforced, specified as a row vector of the form `[min,max]`.

Set the `Focus` property to limit enforcement of the tuning goal to a particular frequency band. Express this value in the frequency units of the control system model you are tuning (`rad/TimeUnit`). For example, suppose `Req` is a tuning goal that you want to apply only between 1 and 100 rad/s. To restrict the tuning goal to this band, use the following command:

```
Req.Focus = [1,100];
```

Default: `[0,Inf]` for continuous time; `[0,pi/Ts]` for discrete time, where `Ts` is the model sample time.

LoopScaling

Toggle for automatically scaling loop signals, specified as `'on'` or `'off'`.

For multiloop or MIMO disturbance rejection tuning goals, the feedback channels are automatically rescaled to equalize the off-diagonal (loop interaction) terms in the open-loop transfer function. Set `LoopScaling` to `'off'` to disable such scaling and shape the unscaled open-loop response.

Default: `'on'`

Location

Location of disturbance, specified as a cell array of character vectors that identify one or more analysis points in the control system to tune. For example, if `Location = {'u'}`, the tuning goal evaluates disturbance rejection at an analysis point `'u'`. If `Location = {'u1','u2'}`, the tuning goal evaluates the rejection at based on the MIMO open-loop response measured at analysis points `'u1'` and `'u2'`.

The initial value of the `Location` property is set by the `distloc` input argument when you create the tuning goal.

Models

Models to which the tuning goal applies, specified as a vector of indices.

Use the `Models` property when tuning an array of control system models with `systeme`, to enforce a tuning goal for a subset of models in the array. For example, suppose you want to apply the tuning goal, `Req`, to the second, third, and fourth models in a model array passed to `systeme`. To restrict enforcement of the tuning goal, use the following command:

```
Req.Models = 2:4;
```

When `Models = NaN`, the tuning goal applies to all models.

Default: NaN

Openings

Feedback loops to open when evaluating the tuning goal, specified as a cell array of character vectors that identify loop-opening locations. The tuning goal is evaluated against the open-loop configuration created by opening feedback loops at the locations you identify.

If you are using the tuning goal to tune a Simulink model of a control system, then `Openings` can include any linear analysis point marked in the model, or any linear analysis point in an `sLTuner` interface associated with the Simulink model. Use `addPoint` to add analysis points and loop openings to the `sLTuner` interface. Use `getPoints` to get the list of analysis points available in an `sLTuner` interface to your model.

If you are using the tuning goal to tune a generalized state-space (`genss`) model of a control system, then `Openings` can include any `AnalysisPoint` location in the control system model. Use `getPoints` to get the list of analysis points available in the `genss` model.

For example, if `Openings = {'u1', 'u2'}`, then the tuning goal is evaluated with loops open at analysis points `u1` and `u2`.

Default: {}

Name

Name of the tuning goal, specified as a character vector.

For example, if `Req` is a tuning goal:

```
Req.Name = 'LoopReq';
```

Default: []

Examples

Constant Minimum Attenuation in Frequency Band

Create a tuning goal that enforces a attenuation of at least a factor of 10 between 0 and 5 rad/s. The tuning goal applies to a disturbance entering a control system at a point identified as `'u'`.

```
Req = TuningGoal.Rejection('u',10);
Req.Name = 'Rejection spec';
Req.Focus = [0 5]
```

Frequency-Dependent Attenuation Profile

Create a tuning goal that enforces an attenuation factor of at least 100 (40 dB) below 1 rad/s, gradually dropping to 1 (0 dB) past 10 rad/s. The tuning goal applies to a disturbance entering a control system at a point identified as `'u'`.

```
attfact = frd([100 100 1 1],[0 1 10 100]);
Req = TuningGoal.Rejection('u',attfact);
```

These commands use a `frd` model to specify the minimum attenuation profile as a function of frequency. The minimum attenuation of 100 below 1 rad/s, together with the minimum attenuation of 1 at the frequencies of 10 and 100 rad/s, specifies the desired rolloff.

`attfact` is converted into a smooth function of frequency that approximates the piecewise specified profile. Display the gain profile using `viewGoal`.

```
viewGoal(Req)
```

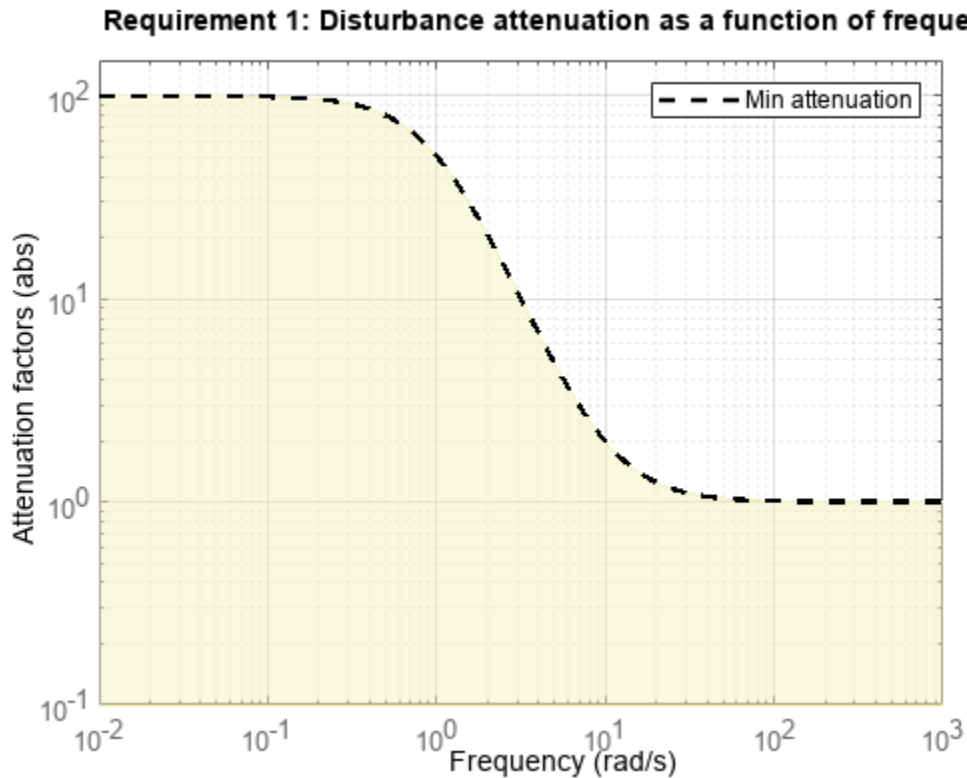

The shaded region indicates where the tuning goal is violated.

Tips

- This tuning goal imposes an implicit stability constraint on the closed-loop sensitivity function measured at `Location`, evaluated with loops opened at the points identified in `Openings`. The dynamics affected by this implicit constraint are the stabilized dynamics for this tuning goal. The `MinDecay` and `MaxRadius` options of `systuneOptions` control the bounds on these implicitly constrained dynamics. If the optimization fails to meet the default bounds, or if the default bounds conflict with other requirements, use `systuneOptions` to change these defaults.

Algorithms

When you tune a control system using a `TuningGoal`, the software converts the tuning goal into a normalized scalar value $f(x)$. In this case, x is the vector of free (tunable) parameters in the control

system. The parameter values are adjusted automatically to minimize $f(x)$ or drive $f(x)$ below 1 if the tuning goal is a hard constraint.

For `TuningGoal.Rejection`, $f(x)$ is given by:

$$f(x) = \max_{\omega \in \Omega} \|W_S(j\omega)S(j\omega, x)\|_{\infty},$$

or its discrete-time equivalent. Here, $S(j\omega, x)$ is the closed-loop sensitivity function measured at the disturbance location. Ω is the frequency interval over which the tuning goal is enforced, specified in the `Focus` property. W_S is a frequency weighting function derived from the specified attenuation profile. The gains of W_S and `MinAttenuation` roughly match for gain values ranging from -20 dB to 60 dB. For numerical reasons, the weighting function levels off outside this range, unless the specified attenuation profile changes slope outside this range. This adjustment is called regularization. Because poles of W_S close to $s = 0$ or $s = \text{Inf}$ might lead to poor numeric conditioning of the `system` optimization problem, it is not recommended to specify attenuation profiles with very low-frequency or very high-frequency dynamics.

To obtain W_S , use:

```
WS = getWeight(Req, Ts)
```

where `Req` is the tuning goal, and `Ts` is the sample time at which you are tuning (`Ts = 0` for continuous time). For more information about regularization and its effects, see “Visualize Tuning Goals”.

Version History

Introduced in R2016a

Functionality moved from Robust Control Toolbox

Behavior changed in R2016a

Prior to R2016a, this functionality required a Robust Control Toolbox license.

See Also

`looptune` | `viewGoal` | `system` | `system` (for `sITuner`) | `looptune` (for `sITuner`) | `TuningGoal.Tracking` | `TuningGoal.LoopShape` | `sITuner`

Topics

“Time-Domain Specifications”

“Visualize Tuning Goals”

“Decoupling Controller for a Distillation Column”

“Tuning of a Two-Loop Autopilot”

TuningGoal.Sensitivity class

Package: TuningGoal

Sensitivity requirement for control system tuning

Description

Use `TuningGoal.Sensitivity` to limit the sensitivity of a feedback loop to disturbances. Constrain the sensitivity to be smaller than one at frequencies where you need good disturbance rejection. Use this tuning goal for control system tuning with tuning commands such as `systemtune` or `looptune`.

Construction

`Req = TuningGoal.Sensitivity(location,maxsens)` creates a tuning goal for limiting the sensitivity to disturbances entering a feedback loop at the specified location. `maxsens` specifies the maximum sensitivity as a function of frequency. You can specify the maximum sensitivity profile as a smooth transfer function or sketch a piecewise error profile using an `frd` model or the `makeweight` command.

See `getSensitivity` for more information about sensitivity functions.)

Input Arguments

location

Location at which the sensitivity to disturbances is constrained, specified as a character vector or cell array of character vectors that identify one or more locations in the control system to tune. What locations are available depends on what kind of system you are tuning:

- If you are tuning a Simulink model of a control system, you can use any linear analysis point marked in the model, or any linear analysis point in an `sLTuner` interface associated with the Simulink model. Use `addPoint` to add analysis points to the `sLTuner` interface. For example, if the `sLTuner` interface contains an analysis point `u`, you can use `'u'` to refer to that point when creating tuning goals. Use `getPoints` to get the list of analysis points available in an `sLTuner` interface to your model.
- If you are tuning a generalized state-space (`genss`) model of a control system, you can use any `AnalysisPoint` location in the control system model. For example, the following code creates a PI loop with an analysis point at the plant input `'u'`.

```
AP = AnalysisPoint('u');
G = tf(1,[1 2]);
C = tunablePID('C','pi');
T = feedback(G*AP*C,1);
```

When creating tuning goals, you can use `'u'` to refer to the analysis point at the plant input. Use `getPoints` to get the list of analysis points available in a `genss` model.

If `location` is a cell array, then the sensitivity requirement applies to the MIMO loop.

maxsens

Maximum sensitivity to disturbances as a function of frequency.

You can specify `maxsens` as a smooth SISO transfer function (`tf`, `zpk`, or `ss` model). Alternatively, you can sketch a piecewise gain profile using a `frd` model or the `makeweight` command. For example, the following `frd` model specifies a maximum sensitivity of 0.01 (-40 dB) at 1 rad/s, increasing to 1 (0 dB) past 50 rad/s.

```
maxsens = frd([0.01 1 1],[1 50 100]);
bodemag(maxsens)
ylim([-45,5])
```

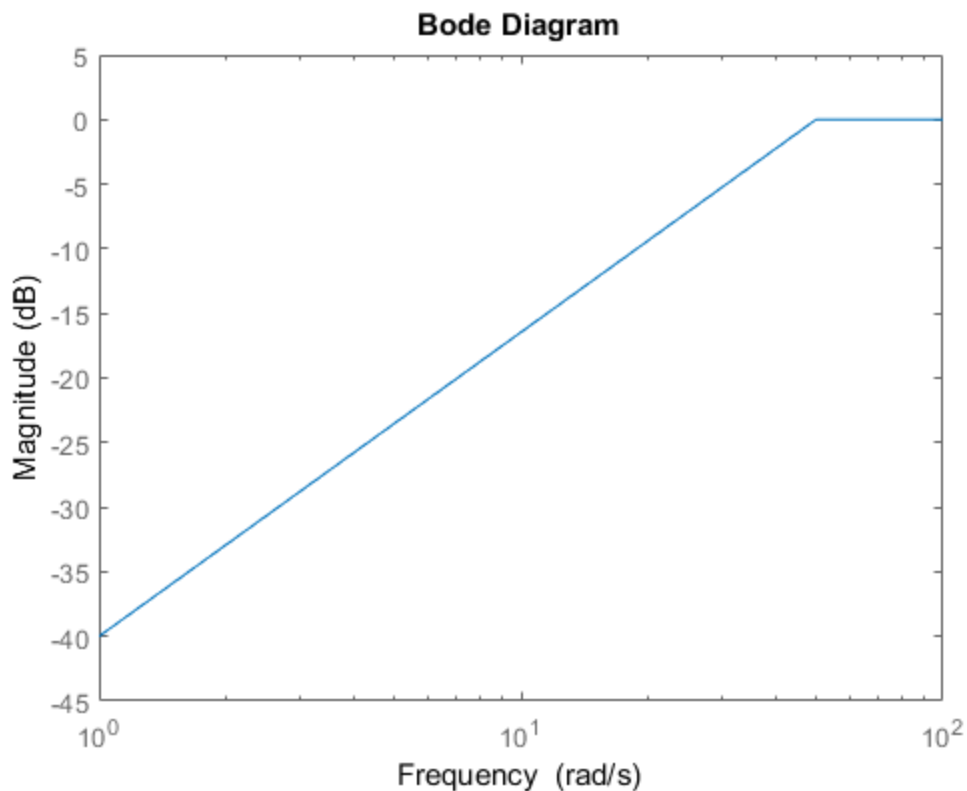

When you use an `frd` model to specify `maxsens`, the software automatically maps your specified gain profile to a `zpk` model whose magnitude approximates the desired gain profile. Use `viewGoal(Req)` to plot the magnitude of that `zpk` model.

If you are tuning in discrete time (that is, using a `genss` model or `sITuner` interface with nonzero T_s), you can specify `maxsens` as a discrete-time model with the same T_s . If you specify `maxsens` in continuous time, the tuning software discretizes it. Specifying the maximum sensitivity profile in discrete time gives you more control over the profile near the Nyquist frequency.

Properties

MaxSensitivity

Maximum sensitivity as a function of frequency, specified as a SISO zpk model.

The software automatically maps the input argument `maxsens` onto a zpk model. The magnitude of this zpk model approximates the desired gain profile. Use `viewGoal(Req)` to plot the magnitude of the zpk model `MaxSensitivity`.

Focus

Frequency band in which tuning goal is enforced, specified as a row vector of the form `[min,max]`.

Set the `Focus` property to limit enforcement of the tuning goal to a particular frequency band. Express this value in the frequency units of the control system model you are tuning (`rad/TimeUnit`). For example, suppose `Req` is a tuning goal that you want to apply only between 1 and 100 rad/s. To restrict the tuning goal to this band, use the following command:

```
Req.Focus = [1,100];
```

Default: `[0,Inf]` for continuous time; `[0,pi/Ts]` for discrete time, where `Ts` is the model sample time.

LoopScaling

Toggle for automatically scaling loop signals, specified as `'on'` or `'off'`.

In multi-loop or MIMO control systems, the feedback channels are automatically rescaled to equalize the off-diagonal terms in the open-loop transfer function (loop interaction terms). Set `LoopScaling` to `'off'` to disable such scaling and shape the unscaled sensitivity function.

Default: `'on'`

Location

Location of disturbance, specified as a cell array of character vectors that identify one or more analysis points in the control system to tune. For example, if `Location = {'u'}`, the tuning goal evaluates the open-loop response measured at an analysis point `'u'`. If `Location = {'u1','u2'}`, the tuning goal evaluates the MIMO open-loop response measured at analysis points `'u1'` and `'u2'`.

The initial value of the `Location` property is set by the `location` input argument when you create the tuning goal.

Models

Models to which the tuning goal applies, specified as a vector of indices.

Use the `Models` property when tuning an array of control system models with `systemtune`, to enforce a tuning goal for a subset of models in the array. For example, suppose you want to apply the tuning goal, `Req`, to the second, third, and fourth models in a model array passed to `systemtune`. To restrict enforcement of the tuning goal, use the following command:

```
Req.Models = 2:4;
```

When `Models = NaN`, the tuning goal applies to all models.

Default: NaN

Openings

Feedback loops to open when evaluating the tuning goal, specified as a cell array of character vectors that identify loop-opening locations. The tuning goal is evaluated against the open-loop configuration created by opening feedback loops at the locations you identify.

If you are using the tuning goal to tune a Simulink model of a control system, then `Openings` can include any linear analysis point marked in the model, or any linear analysis point in an `sITuner` interface associated with the Simulink model. Use `addPoint` to add analysis points and loop openings to the `sITuner` interface. Use `getPoints` to get the list of analysis points available in an `sITuner` interface to your model.

If you are using the tuning goal to tune a generalized state-space (`genss`) model of a control system, then `Openings` can include any `AnalysisPoint` location in the control system model. Use `getPoints` to get the list of analysis points available in the `genss` model.

For example, if `Openings = {'u1', 'u2'}`, then the tuning goal is evaluated with loops open at analysis points `u1` and `u2`.

Default: {}

Name

Name of the tuning goal, specified as a character vector.

For example, if `Req` is a tuning goal:

```
Req.Name = 'LoopReq';
```

Default: []

Examples

Disturbance Sensitivity at Plant Input

Create a tuning goal that limits the sensitivity to disturbance at the plant input of the following control system. The control system contains an analysis point named 'X' at the plant input.

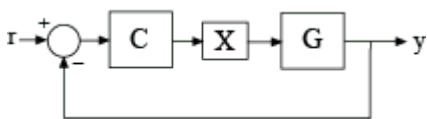

Specify a maximum sensitivity of 0.01 (-40 dB) at 1 rad/s, increasing to 1 (0 dB) past 10 rad/s. Use an `frd` model to sketch this target sensitivity.

```
maxsens = frd([0.01 1 1],[1 10 100]);
Req = TuningGoal.Sensitivity('X',maxsens);
```

The software converts `maxsens` into a smooth function of frequency that approximates the piecewise-specified gain profile. Visualize this function using `viewGoal`.

```
viewGoal(Req)
```

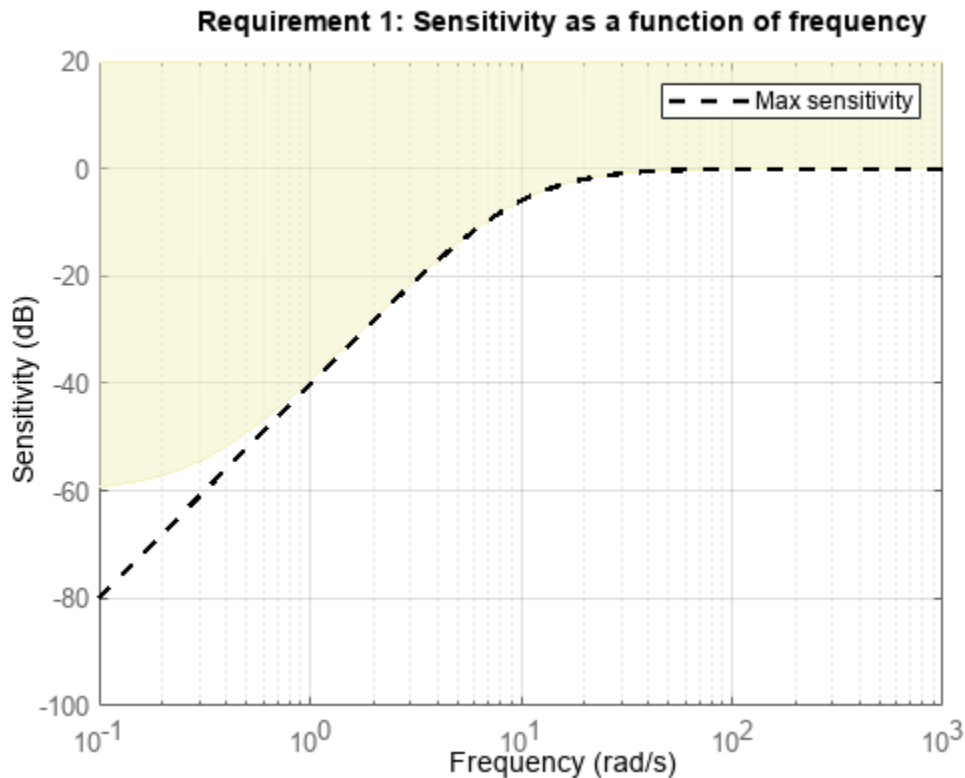

The shaded region indicates regions where the tuning goal is violated. The shaded region differs from the specified gain profile (dashed line) at very low frequencies because of modifications that the software introduces for numeric stability, as described in “Algorithms” on page 1-99.

Sensitivity Goal with Limited Frequency Range and Model Application

Create a tuning goal that specifies a maximum sensitivity of 0.1 (10%) at frequencies below 5 rad/s. Configure the tuning goal to apply only to the second and third plant models.

```
Req = TuningGoal.Sensitivity('u',0.1);
Req.Focus = [0 5];
Req.Models = [2 3];
```

You can use `Req` as an input to `looptune` or `systemtune` when tuning a control system that has an analysis point called 'u'. Setting the `Focus` property limits the application of the tuning goal to frequencies between 0 and 5 rad/s. Setting the `Models` property restricts application of the tuning goal to the second and third models in an array, when you use the tuning goal to tune an array of control system models.

Tips

- This tuning goal imposes an implicit stability constraint on the closed-loop sensitivity function measured at `Location`, evaluated with loops opened at the points identified in `Openings`. The dynamics affected by this implicit constraint are the stabilized dynamics for this tuning goal. The `MinDecay` and `MaxRadius` options of `systemtuneOptions` control the bounds on these implicitly

constrained dynamics. If the optimization fails to meet the default bounds, or if the default bounds conflict with other requirements, use `systemOptions` to change these defaults.

Algorithms

When you tune a control system using a `TuningGoal`, the software converts the tuning goal into a normalized scalar value $f(x)$, where x is the vector of free (tunable) parameters in the control system. The software then adjusts the parameter values to minimize $f(x)$ or to drive $f(x)$ below 1 if the tuning goal is a hard constraint.

For `TuningGoal.Sensitivity`, $f(x)$ is given by:

$$f(x) = \|W_S(s)S(s, x)\|_\infty,$$

or its discrete-time equivalent. Here, $S(s, x)$ is the closed-loop sensitivity function measured at the location specified in the tuning goal. W_S is a frequency weighting function derived from the specified sensitivity profile. The gains of W_S and `1/MaxSensitivity` roughly match for gain values ranging from -20 dB to 60 dB. For numerical reasons, the weighting function levels off outside this range, unless the specified sensitivity profile changes slope outside this range. This adjustment is called regularization. Because poles of W_S close to $s = 0$ or $s = \text{Inf}$ might lead to poor numeric conditioning of the `system` optimization problem, it is not recommended to specify sensitivity profiles with very low-frequency or very high-frequency dynamics.

To obtain W_S , use:

```
WS = getWeight(Req, Ts)
```

where `Req` is the tuning goal, and `Ts` is the sample time at which you are tuning (`Ts = 0` for continuous time). For more information about regularization and its effects, see “Visualize Tuning Goals”.

Version History

Introduced in R2016a

Functionality moved from Robust Control Toolbox

Behavior changed in R2016a

Prior to R2016a, this functionality required a Robust Control Toolbox license.

See Also

`looptune` | `system` | `looptune` (for `slTuner`) | `system` (for `slTuner`) | `viewGoal` | `evalGoal` | `TuningGoal.Gain` | `TuningGoal.LoopShape` | `TuningGoal.Rejection` | `TuningGoal.MinLoopGain` | `TuningGoal.MaxLoopGain` | `slTuner`

Topics

“Frequency-Domain Specifications”

“Visualize Tuning Goals”

TuningGoal.StepRejection class

Package: TuningGoal

Step disturbance rejection requirement for control system tuning

Description

Use `TuningGoal.StepRejection` to specify how a step disturbance injected at a specified location in your control system affects the signal at a specified output location. Use this tuning goal with control system tuning commands such as `systune` or `looptune`.

You can specify the desired response in time-domain terms of peak value, settling time, and damping ratio. Alternatively, you can specify the response as a stable reference model having DC-gain. In that case, the tuning goal is to reject the disturbance as well as or better than the reference model.

To specify disturbance rejection in terms of a frequency-domain attenuation profile, use `TuningGoal.Rejection`.

Construction

`Req = TuningGoal.StepRejection(inputname,outputname,refsys)` creates a tuning goal that constrains how a step disturbance injected at a location `inputname` affects the response at `outputname`. The tuning goal is that the disturbance be rejected as well as or better than the reference system. `inputname` and `outputname` can describe a SISO or MIMO response of your control system. For MIMO responses, the number of inputs must equal the number of outputs.

`Req = TuningGoal.StepRejection(inputname,outputname,peak,tSettle)` specifies an oscillation-free response in terms of a peak value and a settling time.

`Req = TuningGoal.StepRejection(inputname,outputname,peak,tSettle,zeta)` allows for damped oscillations with a damping ratio of at least `zeta`.

Input Arguments

`inputname`

Input signals for the tuning goal, specified as a character vector or, for multiple-input tuning goals, a cell array of character vectors.

- If you are using the tuning goal to tune a Simulink model of a control system, then `inputname` can include:
 - Any model input.
 - Any linear analysis point marked in the model.
 - Any linear analysis point in an `sLTuner` interface associated with the Simulink model. Use `addPoint` to add analysis points to the `sLTuner` interface. Use `getPoints` to get the list of analysis points available in an `sLTuner` interface to your model.

For example, suppose that the `sLTuner` interface contains analysis points `u1` and `u2`. Use `'u1'` to designate that point as an input signal when creating tuning goals. Use `{'u1','u2'}` to designate a two-channel input.

- If you are using the tuning goal to tune a generalized state-space (`genss`) model of a control system, then `inputname` can include:
 - Any input of the `genss` model
 - Any `AnalysisPoint` location in the control system model

For example, if you are tuning a control system model, `T`, then `inputname` can be any input name in `T.InputName`. Also, if `T` contains an `AnalysisPoint` block with a location named `AP_u`, then `inputname` can include `'AP_u'`. Use `getPoints` to get a list of analysis points available in a `genss` model.

If `inputname` is an `AnalysisPoint` location of a generalized model, the input signal for the tuning goal is the implied input associated with the `AnalysisPoint` block:



For more information about analysis points in control system models, see “Mark Signals of Interest for Control System Analysis and Design”.

outputname

Output signals for the tuning goal, specified as a character vector or, for multiple-output tuning goals, a cell array of character vectors.

- If you are using the tuning goal to tune a Simulink model of a control system, then `outputname` can include:
 - Any model output.
 - Any linear analysis point marked in the model.
 - Any linear analysis point in an `sLTuner` interface associated with the Simulink model. Use `addPoint` to add analysis points to the `sLTuner` interface. Use `getPoints` to get the list of analysis points available in an `sLTuner` interface to your model.

For example, suppose that the `sLTuner` interface contains analysis points `y1` and `y2`. Use `'y1'` to designate that point as an output signal when creating tuning goals. Use `{'y1', 'y2'}` to designate a two-channel output.

- If you are using the tuning goal to tune a generalized state-space (`genss`) model of a control system, then `outputname` can include:
 - Any output of the `genss` model
 - Any `AnalysisPoint` location in the control system model

For example, if you are tuning a control system model, `T`, then `outputname` can be any output name in `T.OutputName`. Also, if `T` contains an `AnalysisPoint` block with a location named `AP_u`, then `outputname` can include `'AP_u'`. Use `getPoints` to get a list of analysis points available in a `genss` model.

If `outputname` is an `AnalysisPoint` location of a generalized model, the output signal for the tuning goal is the implied output associated with the `AnalysisPoint` block:



For more information about analysis points in control system models, see “Mark Signals of Interest for Control System Analysis and Design”.

refsys

Reference system for target step rejection, specified as a SISO dynamic system model, such as a `tf`, `zpk`, or `ss` model. `refsys` must be stable and proper, and must have zero DC gain. This restriction ensures perfect rejection of the steady-state disturbance.

`refsys` can be continuous or discrete. If `refsys` is discrete, it can include time delays which are treated as poles at $z = 0$.

For best results, `refsys` and the open-loop response from the disturbance to the output should have similar gains at the frequency where the reference model gain peaks. You can check the peak gain and peak frequency using `getPeakGain`. For example:

```
[gmax, fmax] = getPeakGain(refsys);
```

Use `getIOTTransfer` to extract the corresponding open-loop response from the system you are tuning.

peak

Peak absolute value of target response to disturbance, specified as a scalar value.

tSettle

Target settling time of the response to disturbance, specified as a positive scalar value, in the time units of the control system you are tuning.

zeta

Minimum damping ratio of oscillations in the response to disturbance, specified as a value between 0 and 1.

Default: 1

Properties

ReferenceModel

Reference system for target response to step disturbance, specified as a SISO (`zpk`) model. The step response of this model specifies how the output signals specified by `outputname` should respond to the step disturbance at `inputname`.

If you use the `refsys` input argument to create the tuning goal, then the value of `ReferenceModel` is `zpk(refsys)`.

If you use the `peak`, `tSample`, and `zeta` input arguments, then `ReferenceModel` is a zpk representation of the first-order or second-order transfer function whose step response has the specified characteristics.

InputScaling

Input signal scaling, specified as a vector of positive real values.

Use this property to specify the relative amplitude of each entry in vector-valued input signals when the choice of units results in a mix of small and large signals. This information is used to scale the closed-loop transfer function from `Input` to `Output` when the tuning goal is evaluated.

Suppose $T(s)$ is the closed-loop transfer function from `Input` to `Output`. The tuning goal is evaluated for the scaled transfer function $D_o^{-1}T(s)D_i$. The diagonal matrices D_o and D_i have the `OutputScaling` and `InputScaling` values on the diagonal, respectively.

The default value, `[]`, means no scaling.

Default: `[]`

OutputScaling

Output signal scaling, specified as a vector of positive real values.

Use this property to specify the relative amplitude of each entry in vector-valued output signals when the choice of units results in a mix of small and large signals. This information is used to scale the closed-loop transfer function from `Input` to `Output` when the tuning goal is evaluated.

Suppose $T(s)$ is the closed-loop transfer function from `Input` to `Output`. The tuning goal is evaluated for the scaled transfer function $D_o^{-1}T(s)D_i$. The diagonal matrices D_o and D_i have the `OutputScaling` and `InputScaling` values on the diagonal, respectively.

The default value, `[]`, means no scaling.

Default: `[]`

Input

Names of disturbance input locations, specified as a cell array of character vectors. This property is initially populated by the `inputname` argument when you create the tuning goal.

Output

Names of locations at which response to step disturbance is measured, specified as a cell array of character vectors. This property is initially populated by the `outputname` argument when you create the tuning goal.

Models

Models to which the tuning goal applies, specified as a vector of indices.

Use the `Models` property when tuning an array of control system models with `systemtune`, to enforce a tuning goal for a subset of models in the array. For example, suppose you want to apply the tuning goal, `Req`, to the second, third, and fourth models in a model array passed to `systemtune`. To restrict enforcement of the tuning goal, use the following command:

```
Req.Models = 2:4;
```

When `Models = NaN`, the tuning goal applies to all models.

Default: NaN

Openings

Feedback loops to open when evaluating the tuning goal, specified as a cell array of character vectors that identify loop-opening locations. The tuning goal is evaluated against the open-loop configuration created by opening feedback loops at the locations you identify.

If you are using the tuning goal to tune a Simulink model of a control system, then `Openings` can include any linear analysis point marked in the model, or any linear analysis point in an `sLTuner` interface associated with the Simulink model. Use `addPoint` to add analysis points and loop openings to the `sLTuner` interface. Use `getPoints` to get the list of analysis points available in an `sLTuner` interface to your model.

If you are using the tuning goal to tune a generalized state-space (`genss`) model of a control system, then `Openings` can include any `AnalysisPoint` location in the control system model. Use `getPoints` to get the list of analysis points available in the `genss` model.

For example, if `Openings = {'u1', 'u2'}`, then the tuning goal is evaluated with loops open at analysis points `u1` and `u2`.

Default: {}

Name

Name of the tuning goal, specified as a character vector.

For example, if `Req` is a tuning goal:

```
Req.Name = 'LoopReq';
```

Default: []

Examples

Specify First-Order or Second-Order Step Disturbance Response Characteristics

Create a requirement that specifies the step disturbance response in terms of peak time-domain response, settling time, and damping of oscillations.

Suppose you want the response at `'y'` to a disturbance injected at `'d'` to never exceed an absolute value of 0.25, and to settle within 5 seconds. Create a `TuningGoal.StepRejection` requirement that captures these specifications and also specifies non-oscillatory response.

```
Req1 = TuningGoal.StepRejection('d', 'y', 0.25, 5);
```

Omitting an explicit value for the damping ratio, `zeta`, is equivalent to setting `zeta = 1`. Therefore, `Req` specifies a non-oscillatory response. The software converts the peak value and settling time into a reference transfer function whose step response has the desired time-domain profile. This transfer function is stored in the `ReferenceModel` property of `Req`.

```
Req1.ReferenceModel
```

```
ans =
```

```
0.92883 s
-----
(s+1.367)^2
```

Continuous-time zero/pole/gain model.

Confirm the target response by displaying Req.

```
figure()
viewGoal(Req1)
```

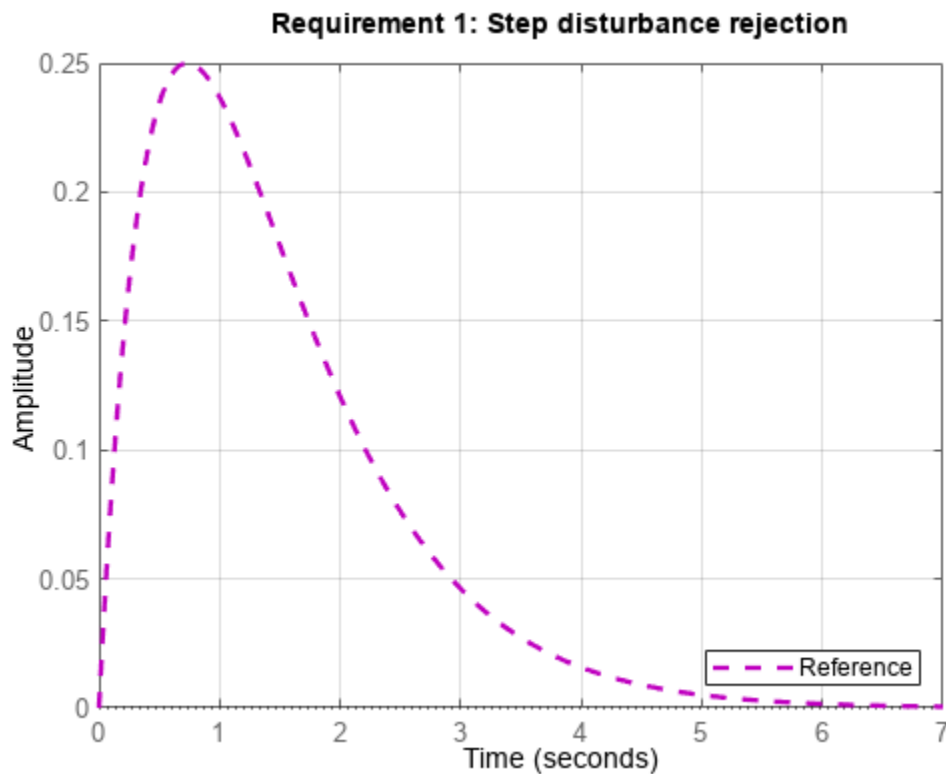

Suppose your application can tolerate oscillations provided the damping ratio is less than 0.4. Create a requirement that specifies this disturbance response.

```
Req2 = TuningGoal.StepRejection('d', 'y', 0.25, 5, 0.4);
figure()
viewGoal(Req2)
```

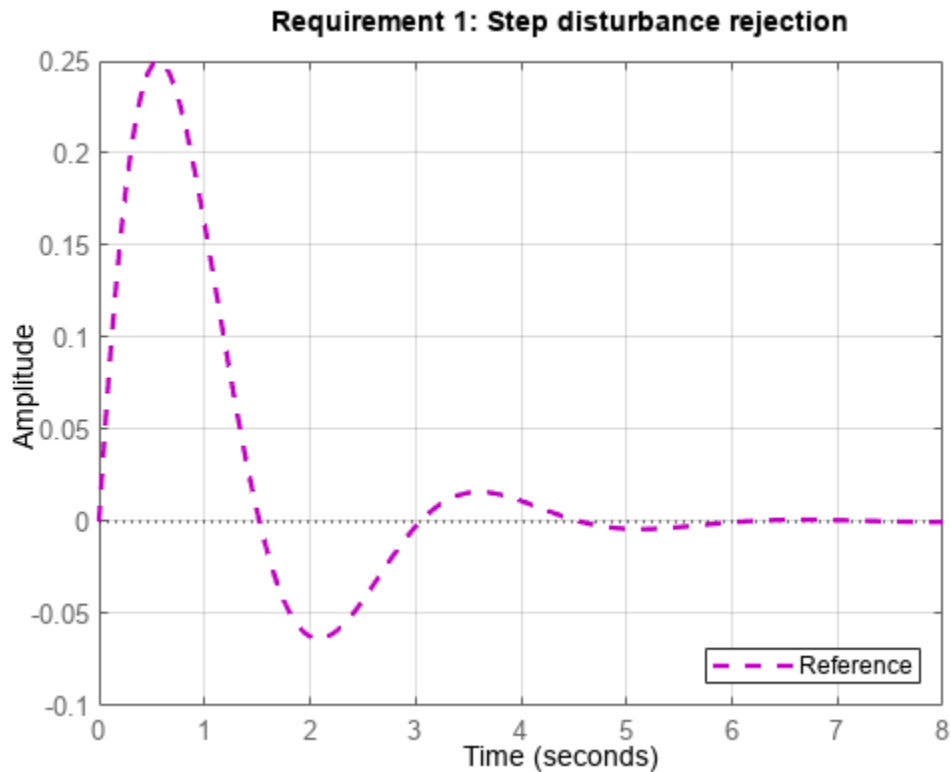

Step Disturbance Rejection with Custom Reference Model

Create a requirement that specifies the step disturbance response as a transfer function.

Suppose you want the response to a disturbance injected at an analysis point `d` in your control system and measured at a point `y` to be rejected at least as well as the transfer function

$$H(s) = \frac{s}{s^2 + 2s + 1}.$$

Create a `TuningGoal.StepRejection` requirement.

```
H = tf([1 0],[1 2 1]);
Req = TuningGoal.StepRejection('d','y',H);
```

Display the requirement.

```
viewGoal(Req)
```

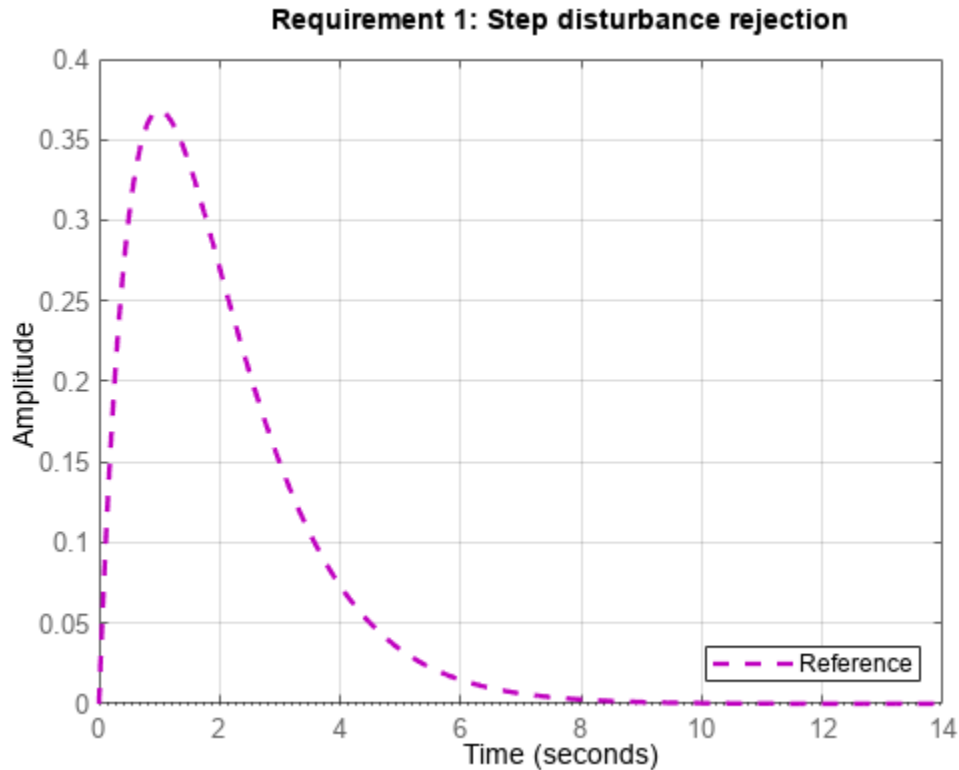

The plot displayed by `viewGoal` shows the step response of the specified transfer function. This response is the target time-domain response to disturbance.

Tips

- This tuning goal imposes an implicit stability constraint on the closed-loop transfer function from **Input** to **Output**, evaluated with loops opened at the points identified in **Openings**. The dynamics affected by this implicit constraint are the stabilized dynamics for this tuning goal. The `MinDecay` and `MaxRadius` options of `systuneOptions` control the bounds on these implicitly constrained dynamics. If the optimization fails to meet the default bounds, or if the default bounds conflict with other requirements, use `systuneOptions` to change these defaults.

Algorithms

When you tune a control system using a `TuningGoal`, the software converts the tuning goal into a normalized scalar value $f(x)$, where x is the vector of free (tunable) parameters in the control system. The software then adjusts the parameter values to minimize $f(x)$ or to drive $f(x)$ below 1 if the tuning goal is a hard constraint.

`TuningGoal.StepRejection` aims to keep the gain from disturbance to output below the gain of the reference model. The scalar value of the tuning goal $f(x)$ is given by:

$$f(x) = \|W_F(s)T_{dy}(s, x)\|_{\infty},$$

or its discrete-time equivalent. Here, $T_{dy}(s,x)$ is the closed-loop transfer function from **Input** to **Output**, and $\| \cdot \|_{\infty}$ denotes the H_{∞} norm (see `norm`). W_F is a frequency weighting function derived from the step-rejection profile you specify in the tuning goal. The gains of W_F and `1/ReferenceModel` roughly match for gain values within 60 dB of the peak gain. For numerical reasons, the weighting function levels off outside this range, unless you specify a reference model that changes slope outside this range. This adjustment is called regularization. Because poles of W_F close to $s = 0$ or $s = \text{Inf}$ might lead to poor numeric conditioning of the `systemtune` optimization problem, it is not recommended to specify reference models with very low-frequency or very high-frequency dynamics.

To obtain W_F , use:

```
WF = getWeight(Req,Ts)
```

where `Req` is the tuning goal, and `Ts` is the sample time at which you are tuning (`Ts = 0` for continuous time). For more information about regularization and its effects, see “Visualize Tuning Goals”.

Version History

Introduced in R2016a

Functionality moved from Robust Control Toolbox

Behavior changed in R2016a

Prior to R2016a, this functionality required a Robust Control Toolbox license.

See Also

`looptune` | `systemtune` | `systemtune` (for `sITuner`) | `looptune` (for `sITuner`) | `viewGoal` | `evalGoal` | `TuningGoal.Gain` | `TuningGoal.LoopShape` | `sITuner`

Topics

“Time-Domain Specifications”

“Visualize Tuning Goals”

“Tune Control Systems with SYSTUNE”

“Tune Control Systems in Simulink”

TuningGoal.StepTracking class

Package: TuningGoal

Step response requirement for control system tuning

Description

Use `TuningGoal.StepTracking` to specify a target step response from specified inputs to specified outputs of a control system. Use this tuning goal with control system tuning commands such as `systune` or `looptune`.

Construction

`Req = TuningGoal.StepTracking(inputname,outputname,refsys)` creates a tuning goal that constrains the step response between the specified signal locations to match the step response of a stable reference system, `refsys`. The constraint is satisfied when the relative difference between the tuned and target responses falls within a tolerance specified by the `RelGap` property of the tuning goal (see “Properties” on page 1-112). `inputname` and `outputname` can describe a SISO or MIMO response of your control system. For MIMO responses, the number of inputs must equal the number of outputs.

`Req = TuningGoal.StepTracking(inputname,outputname,tau)` specifies the desired step response as a first-order response with time constant `tau`:

$$\text{Req.ReferenceModel} = \frac{1/\tau}{s + 1/\tau}.$$

`Req = TuningGoal.StepTracking(inputname,outputname,tau,overshoot)` specifies the desired step response as a second-order response with natural period `tau`, natural frequency `1/tau`, and percent overshoot `overshoot`:

$$\text{Req.ReferenceModel} = \frac{(1/\tau)^2}{s^2 + 2(\zeta/\tau)s + (1/\tau)^2}.$$

The damping is given by $\zeta = \cos(\text{atan2}(\pi, -\log(\text{overshoot}/100)))$.

Input Arguments

`inputname`

Input signals for the tuning goal, specified as a character vector or, for multiple-input tuning goals, a cell array of character vectors.

- If you are using the tuning goal to tune a Simulink model of a control system, then `inputname` can include:
 - Any model input.
 - Any linear analysis point marked in the model.

- Any linear analysis point in an `sLTuner` interface associated with the Simulink model. Use `addPoint` to add analysis points to the `sLTuner` interface. Use `getPoints` to get the list of analysis points available in an `sLTuner` interface to your model.

For example, suppose that the `sLTuner` interface contains analysis points `u1` and `u2`. Use `'u1'` to designate that point as an input signal when creating tuning goals. Use `{'u1', 'u2'}` to designate a two-channel input.

- If you are using the tuning goal to tune a generalized state-space (`genss`) model of a control system, then `inputname` can include:
 - Any input of the `genss` model
 - Any `AnalysisPoint` location in the control system model

For example, if you are tuning a control system model, `T`, then `inputname` can be any input name in `T.InputName`. Also, if `T` contains an `AnalysisPoint` block with a location named `AP_u`, then `inputname` can include `'AP_u'`. Use `getPoints` to get a list of analysis points available in a `genss` model.

If `inputname` is an `AnalysisPoint` location of a generalized model, the input signal for the tuning goal is the implied input associated with the `AnalysisPoint` block:



For more information about analysis points in control system models, see “Mark Signals of Interest for Control System Analysis and Design”.

outputname

Output signals for the tuning goal, specified as a character vector or, for multiple-output tuning goals, a cell array of character vectors.

- If you are using the tuning goal to tune a Simulink model of a control system, then `outputname` can include:
 - Any model output.
 - Any linear analysis point marked in the model.
 - Any linear analysis point in an `sLTuner` interface associated with the Simulink model. Use `addPoint` to add analysis points to the `sLTuner` interface. Use `getPoints` to get the list of analysis points available in an `sLTuner` interface to your model.

For example, suppose that the `sLTuner` interface contains analysis points `y1` and `y2`. Use `'y1'` to designate that point as an output signal when creating tuning goals. Use `{'y1', 'y2'}` to designate a two-channel output.

- If you are using the tuning goal to tune a generalized state-space (`genss`) model of a control system, then `outputname` can include:
 - Any output of the `genss` model

- Any `AnalysisPoint` location in the control system model

For example, if you are tuning a control system model, `T`, then `outputname` can be any output name in `T.OutputName`. Also, if `T` contains an `AnalysisPoint` block with a location named `AP_u`, then `outputname` can include `'AP_u'`. Use `getPoints` to get a list of analysis points available in a `genss` model.

If `outputname` is an `AnalysisPoint` location of a generalized model, the output signal for the tuning goal is the implied output associated with the `AnalysisPoint` block:



For more information about analysis points in control system models, see “Mark Signals of Interest for Control System Analysis and Design”.

refsys

Reference system for target step response, specified as a dynamic system model, such as a `tf`, `zpk`, or `ss` model. `refsys` must be stable and must have DC gain of 1 (zero steady-state error).

`refsys` can be continuous or discrete. If `refsys` is discrete, it can include time delays which are treated as poles at $z = 0$.

`refsys` can be MIMO, provided that it is square and that its DC singular value (`sigma`) is 1. If `refsys` is a MIMO model, then its number of inputs and outputs must match the dimensions of `inputname` and `outputname`.

For best results, `refsys` should also include intrinsic system characteristics such as non-minimum-phase zeros (undershoot).

tau

Time constant or natural period of target step response, specified as a positive scalar.

If you use the syntax `Req = TuningGoal.StepTracking(inputname,outputname,tau)` to specify a first-order target response, then `tau` is the time constant of the response decay. In that case, the target is the step response of the system given by:

$$\text{Req.ReferenceModel} = \frac{1/\tau}{s + 1/\tau}$$

If you use the syntax `Req = TuningGoal.StepTracking(inputname,outputname,tau,overshoot)` to specify a second-order target response, then `tau` is the inverse of the natural frequency of the response. In that case, the target is the step response of the system given by:

$$\text{Req.ReferenceModel} = \frac{(1/\tau)^2}{s^2 + 2(\zeta/\tau)s + (1/\tau)^2}$$

The damping of the system is given by $\zeta = \cos(\text{atan2}(\pi, -\log(\text{overshoot}/100)))$.

overshoot

Percent overshoot of target step response, specified as a scalar value in the range (0,100).

Properties**ReferenceModel**

Reference system for target step response, specified as a SISO or MIMO state-space (ss) model. When you use the tuning goal to tune a control system, the step response from `inputname` to `outputname` is tuned to match this target response to within the tolerance specified by the `RelGap` property.

If you use the `refsys` input argument to create the tuning goal, then the value of `ReferenceModel` is `ss(refsys)`.

If you use the `tau` or `tau` and `overshoot` input arguments, then `ReferenceModel` is a state-space representation of the corresponding first-order or second-order transfer function.

`ReferenceModel` must be stable and have unit DC gain (zero steady-state error). For best results, `ReferenceModel` should also include intrinsic system characteristics such as non-minimum-phase zeros (undershoot).

RelGap

Maximum relative matching error, specified as a positive scalar value. This property specifies the matching tolerance as the maximum relative gap between the target and actual step responses. The relative gap is defined as:

$$\text{gap} = \frac{\|y(t) - y_{ref}(t)\|_2}{\|1 - y_{ref}(t)\|_2}.$$

$y(t) - y_{ref}(t)$ is the response mismatch, and $1 - y_{ref}(t)$ is the step-tracking error of the target model. $\|\cdot\|_2$ denotes the signal energy (2-norm).

Increase the value of `RelGap` to loosen the matching tolerance.

Default: 0.1

InputScaling

Reference signal scaling, specified as a vector of positive real values.

For a MIMO tracking requirement, when the choice of units results in a mix of small and large signals in different channels of the response, use this property to specify the relative amplitude of each entry in the vector-valued step input. This information is used to scale the off-diagonal terms in the transfer function from reference to tracking error. This scaling ensures that cross-couplings are measured relative to the amplitude of each reference signal.

For example, suppose that `Req` is a tuning goal that signals `{ 'y1', 'y2' }` track reference signals `{ 'r1', 'r2' }`. Suppose further that you require the outputs to track the references with less than 10% cross-coupling. If `r1` and `r2` have comparable amplitudes, then it is sufficient to keep the gains from `r1` to `y2` and `r2` and `y1` below 0.1. However, if `r1` is 100 times larger than `r2`, the gain from `r1`

to y_2 must be less than 0.001 to ensure that r_1 changes y_2 by less than 10% of the r_2 target. To ensure this result, set the `InputScaling` property as follows.

```
Req.InputScaling = [100,1];
```

This tells the software to take into account that the first reference signal is 100 times greater than the second reference signal.

The default value, `[]`, means no scaling.

Default: `[]`

Input

Input signal names, specified as a cell array of character vectors that identify the inputs of the transfer function that the tuning goal constrains. The initial value of the `Input` property is set by the `inputname` input argument when you construct the tuning goal.

Output

Output signal names, specified as a cell array of character vectors that identify the outputs of the transfer function that the tuning goal constrains. The initial value of the `Output` property is set by the `outputname` input argument when you construct the tuning goal.

Models

Models to which the tuning goal applies, specified as a vector of indices.

Use the `Models` property when tuning an array of control system models with `systemtune`, to enforce a tuning goal for a subset of models in the array. For example, suppose you want to apply the tuning goal, `Req`, to the second, third, and fourth models in a model array passed to `systemtune`. To restrict enforcement of the tuning goal, use the following command:

```
Req.Models = 2:4;
```

When `Models = NaN`, the tuning goal applies to all models.

Default: `NaN`

Openings

Feedback loops to open when evaluating the tuning goal, specified as a cell array of character vectors that identify loop-opening locations. The tuning goal is evaluated against the open-loop configuration created by opening feedback loops at the locations you identify.

If you are using the tuning goal to tune a Simulink model of a control system, then `Openings` can include any linear analysis point marked in the model, or any linear analysis point in an `sLTuner` interface associated with the Simulink model. Use `addPoint` to add analysis points and loop openings to the `sLTuner` interface. Use `getPoints` to get the list of analysis points available in an `sLTuner` interface to your model.

If you are using the tuning goal to tune a generalized state-space (`genss`) model of a control system, then `Openings` can include any `AnalysisPoint` location in the control system model. Use `getPoints` to get the list of analysis points available in the `genss` model.

For example, if `Openings = {'u1', 'u2'}`, then the tuning goal is evaluated with loops open at analysis points `u1` and `u2`.

Default: `{}`

Name

Name of the tuning goal, specified as a character vector.

For example, if `Req` is a tuning goal:

```
Req.Name = 'LoopReq';
```

Default: `[]`

Examples

Step Response Requirement with Specified Tolerance

Create a requirement for the step response from a signal named `'r'` to a signal named `'y'`. Constrain the step response to match the transfer function $H = 10/(s+10)$, but allow 20% relative variation between the target the tuned responses.

```
H = tf(10,[1 10]);  
Req = TuningGoal.StepResp('r','y',H);
```

By default, this requirement allows a relative gap of 0.1 between the target and tuned responses. To change the relative gap to 20%, set the `RelGap` property of the requirement.

```
Req.RelGap = 0.2;
```

Examine the requirement.

```
viewGoal(Req);
```

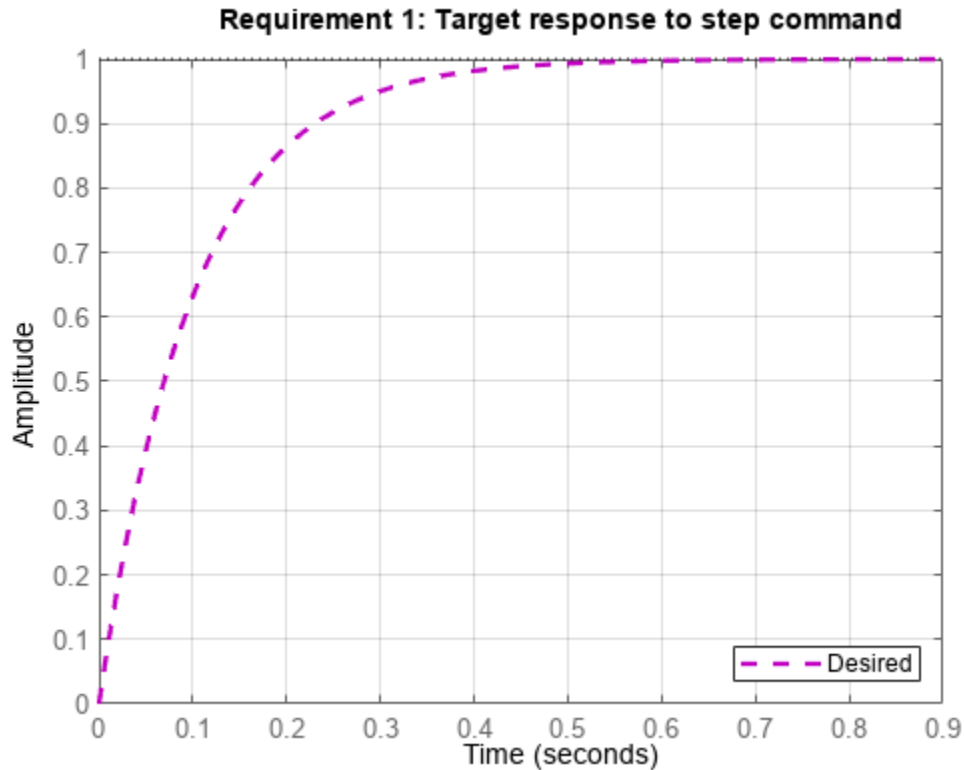

The dashed line shows the target step response specified by this requirement. You can use this requirement to tune a control system model, T , that contains valid input and output locations named 'r' and 'y'. If you do so, the command `viewGoal(Req,T)` plots the achieved step response from 'r' to 'y' for comparison to the target response.

First-Order Step Response With Known Time Constant

Create a requirement that specifies a first-order step response with time constant of 5 seconds. Create the requirement for the step response from a signal named 'r' to a signal named 'y'.

```
Req = TuningGoal.StepResp('r','y',5);
```

When you use this requirement to tune a control system model, T , the time constant 5 is taken to be expressed in the prevailing units of the control system. For example, if T is a `genss` model and the property `T.TimeUnit` is 'seconds', then this requirement specifies a target time constant of 5 seconds for the response from the input 'r' to the output 'y' of 'T'.

The specified time constant is converted into a reference state-space model stored in the `ReferenceModel` property of the requirement.

```
refsys = tf(Req.ReferenceModel)
```

```
refsys =
```

```
0.2
```

$$\frac{1}{s + 0.2}$$

Continuous-time transfer function.

As expected, `refsys` is a first-order model.

Examine the requirement. The `viewGoal` command displays the target response, which is the step response of the reference model.

```
viewGoal(Req);
```

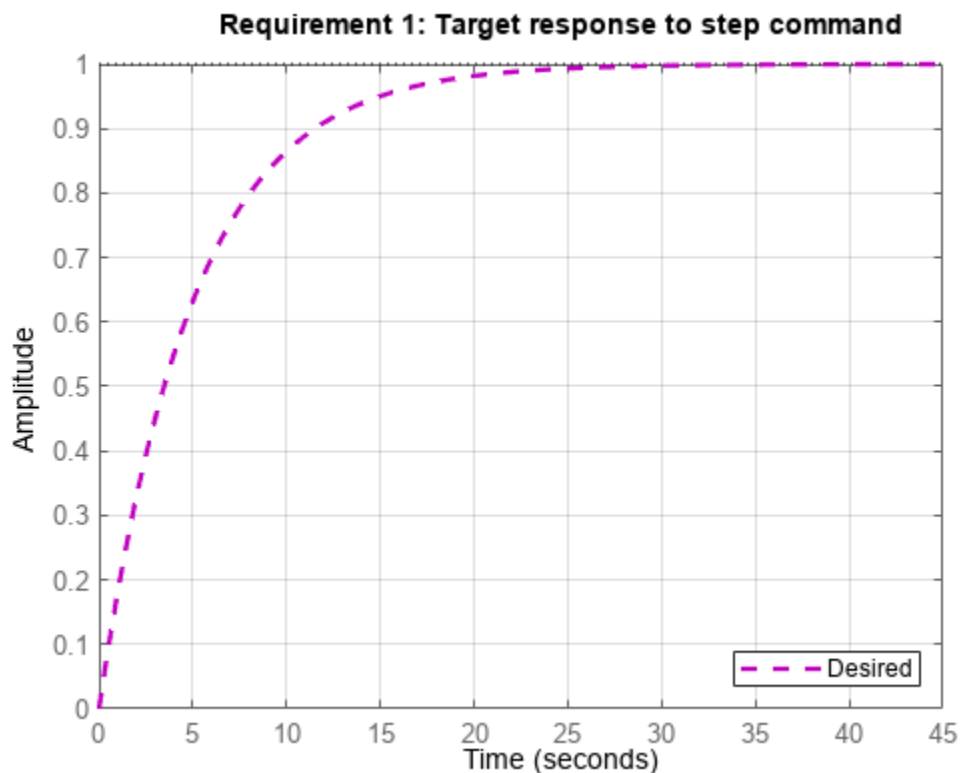

The dashed line shows the target step response specified by this requirement, a first-order response with a time constant of five seconds.

Second-Order Step Response With Known Natural Period and Overshoot

Create a requirement that specifies a second-order step response with a natural period of 5 seconds, and a 10% overshoot. Create the requirement for the step response from a signal named 'r' to a signal named 'y'.

```
Req = TuningGoal.StepResp('r','y',5,10);
```

When you use this requirement to tune a control system model, `T`, the natural period 5 is taken to be expressed in the prevailing units of the control system. For example, if `T` is a `genss` model and the

property `T.TimeUnit` is 'seconds', then this requirement specifies a target natural period of 5 seconds for the response from the input 'r' to the output 'y' of 'T'.

The specified parameters of the response is converted into a reference state-space model stored in the `ReferenceModel` property of the requirement.

```
refsys = tf(Req.ReferenceModel)
```

```
refsys =
```

```
      0.04
-----
s^2 + 0.2365 s + 0.04
```

Continuous-time transfer function.

As expected, `refsys` is a second-order model.

Examine the requirement. The `viewGoal` command displays the target response, which is the step response of the reference model.

```
viewGoal(Req);
```

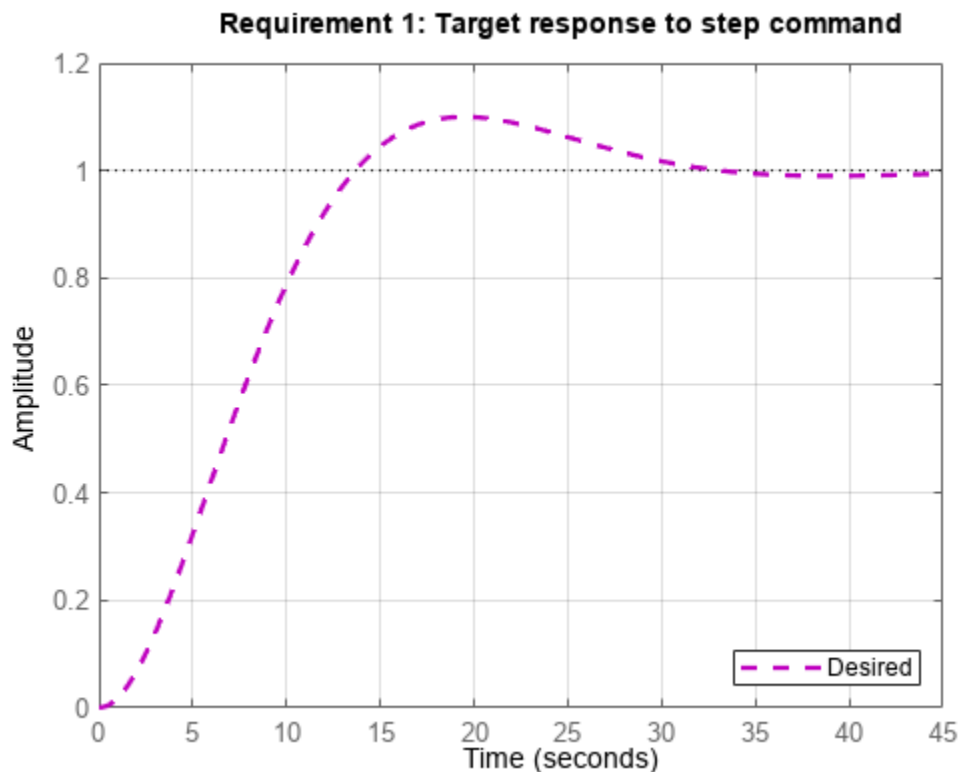

The dashed line shows the target step response specified by this requirement, a second-order response with 10% overshoot and a natural period of five seconds.

Tracking Goal with Limited Model Application and Additional Loop Openings

Create a tuning goal that specifies a first-order step response with time constant of 5 seconds. Set the `Models` and `Openings` properties to further configure the tuning goal's applicability.

```
Req = TuningGoal.StepTracking('r','y',5);
Req.Models = [2 3];
Req.Openings = 'OuterLoop'
```

When tuning a control system that has an input 'r', an output 'y', and an analysis-point location 'OuterLoop', you can use `Req` as an input to `looptune` or `systune`. Setting the `Openings` property specifies that the step response from 'r' to 'y' is measured with the loop opened at 'OuterLoop'. When tuning an array of control system models, setting the `Models` property restricts how the tuning goal is applied. In this example, the tuning goal applies only to the second and third models in an array.

Tips

- This tuning goal imposes an implicit stability constraint on the closed-loop transfer function from `Input` to `Output`, evaluated with loops opened at the points identified in `Openings`. The dynamics affected by this implicit constraint are the stabilized dynamics for this tuning goal. The `MinDecay` and `MaxRadius` options of `systuneOptions` control the bounds on these implicitly constrained dynamics. If the optimization fails to meet the default bounds, or if the default bounds conflict with other requirements, use `systuneOptions` to change these defaults.

Algorithms

When you tune a control system using a `TuningGoal`, the software converts the tuning goal into a normalized scalar value $f(x)$. Here, x is the vector of free (tunable) parameters in the control system. The software then adjusts the parameter values to minimize $f(x)$ or to drive $f(x)$ below 1 if the tuning goal is a hard constraint.

For `TuningGoal.StepTracking`, $f(x)$ is given by:

$$f(x) = \frac{\left\| \frac{1}{s}(T(s,x) - T_{ref}(s)) \right\|_2}{\text{RelGap} \left\| \frac{1}{s}(T_{ref}(s) - I) \right\|_2}.$$

$T(s,x)$ is the closed-loop transfer function from `Input` to `Output` with parameter values x , and $T_{ref}(s)$ is the reference model specified in the `ReferenceModel` property. $\| \cdot \|_2$ denotes the H_2 norm (see `norm`).

Version History

Introduced in R2016a

Functionality moved from Robust Control Toolbox

Behavior changed in R2016a

Prior to R2016a, this functionality required a Robust Control Toolbox license.

See Also

looptune | systune | looptune (for sITuner) | systune (for sITuner) | viewGoal | evalGoal | TuningGoal.Tracking | TuningGoal.Overshoot

Topics

“Time-Domain Specifications”

“PID Tuning for Setpoint Tracking vs. Disturbance Rejection”

TuningGoal.Tracking class

Package: TuningGoal

Tracking requirement for control system tuning

Description

Use `TuningGoal.Tracking` to specify a frequency-domain tracking requirement between specified inputs and outputs. This tuning goal specifies the maximum relative error (gain from reference input to tracking error) as a function of frequency. Use this tuning goal for control system tuning with tuning commands such as `sys tune` or `looptune`.

You can specify the maximum error profile directly by providing a transfer function. Alternatively, you can specify a target DC error, peak error, and response time. These parameters are converted to the following transfer function that describes the maximum frequency-domain tracking error:

$$\text{MaxError} = \frac{(\text{PeakError})s + \omega_c(\text{DCError})}{s + \omega_c}.$$

Here, ω_c is $2/(\text{response time})$. The following plot illustrates these relationships for an example set of values.

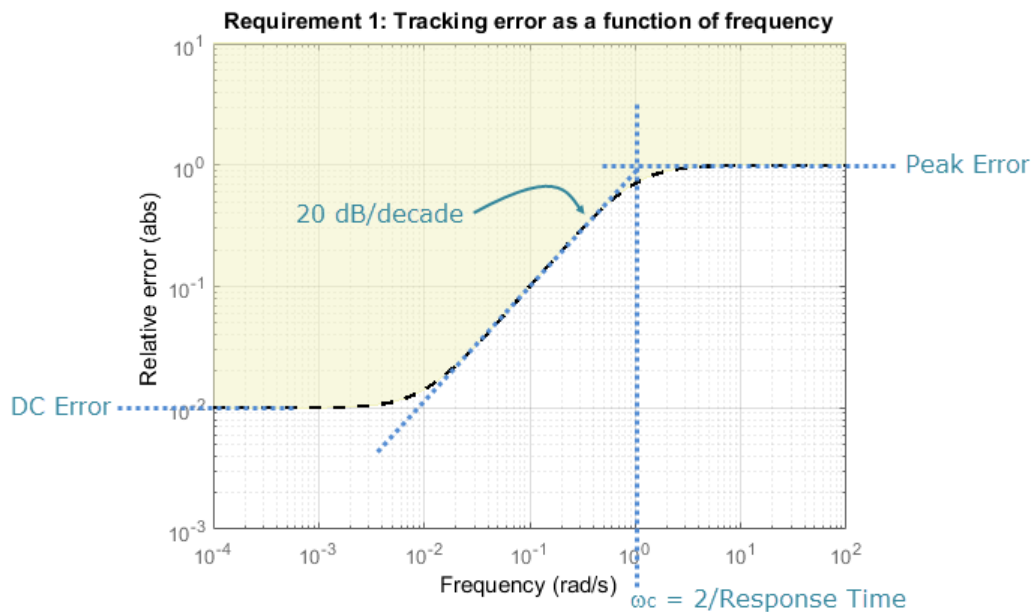

Construction

`Req = TuningGoal.Tracking(inputname, outputname, responsetime, dcerror, peakerror)` creates a tuning goal `Req` that constrains the tracking performance from `inputname` to `outputname` in the frequency domain. This tuning goal specifies a maximum error profile as a function of frequency given by:

$$\text{MaxError} = \frac{(\text{PeakError})s + \omega_c(\text{DCError})}{s + \omega_c}.$$

The tracking bandwidth $\omega_c = 2/\text{responsetime}$. The maximum relative steady-state error is given by `dcerror`, and `peakerror` gives the peak relative error across all frequencies.

You can specify a MIMO tracking requirement by specifying signal names or a cell array of multiple signal names for `inputname` or `outputname`. For MIMO tracking requirements, use the `InputScaling` property to help limit cross-coupling. See “Properties” on page 1-123.

`Req = TuningGoal.Tracking(inputname,outputname,maxerror)` specifies the maximum relative error as a function of frequency. You can specify the target error profile (maximum gain from reference signal to tracking error signal) as a smooth transfer function. Alternatively, you can sketch a piecewise error profile using an `frd` model.

Input Arguments

`inputname`

Input signals for the tuning goal, specified as a character vector or, for multiple-input tuning goals, a cell array of character vectors.

- If you are using the tuning goal to tune a Simulink model of a control system, then `inputname` can include:
 - Any model input.
 - Any linear analysis point marked in the model.
 - Any linear analysis point in an `sLTuner` interface associated with the Simulink model. Use `addPoint` to add analysis points to the `sLTuner` interface. Use `getPoints` to get the list of analysis points available in an `sLTuner` interface to your model.

For example, suppose that the `sLTuner` interface contains analysis points `u1` and `u2`. Use `'u1'` to designate that point as an input signal when creating tuning goals. Use `{'u1','u2'}` to designate a two-channel input.

- If you are using the tuning goal to tune a generalized state-space (`genss`) model of a control system, then `inputname` can include:
 - Any input of the `genss` model
 - Any `AnalysisPoint` location in the control system model

For example, if you are tuning a control system model, `T`, then `inputname` can be any input name in `T.InputName`. Also, if `T` contains an `AnalysisPoint` block with a location named `AP_u`, then `inputname` can include `'AP_u'`. Use `getPoints` to get a list of analysis points available in a `genss` model.

If `inputname` is an `AnalysisPoint` location of a generalized model, the input signal for the tuning goal is the implied input associated with the `AnalysisPoint` block:



For more information about analysis points in control system models, see “Mark Signals of Interest for Control System Analysis and Design”.

outputname

Output signals for the tuning goal, specified as a character vector or, for multiple-output tuning goals, a cell array of character vectors.

- If you are using the tuning goal to tune a Simulink model of a control system, then `outputname` can include:
 - Any model output.
 - Any linear analysis point marked in the model.
 - Any linear analysis point in an `sITuner` interface associated with the Simulink model. Use `addPoint` to add analysis points to the `sITuner` interface. Use `getPoints` to get the list of analysis points available in an `sITuner` interface to your model.

For example, suppose that the `sITuner` interface contains analysis points `y1` and `y2`. Use `'y1'` to designate that point as an output signal when creating tuning goals. Use `{'y1', 'y2'}` to designate a two-channel output.

- If you are using the tuning goal to tune a generalized state-space (`genss`) model of a control system, then `outputname` can include:
 - Any output of the `genss` model
 - Any `AnalysisPoint` location in the control system model

For example, if you are tuning a control system model, `T`, then `outputname` can be any output name in `T.OutputName`. Also, if `T` contains an `AnalysisPoint` block with a location named `AP_u`, then `outputname` can include `'AP_u'`. Use `getPoints` to get a list of analysis points available in a `genss` model.

If `outputname` is an `AnalysisPoint` location of a generalized model, the output signal for the tuning goal is the implied output associated with the `AnalysisPoint` block:



For more information about analysis points in control system models, see “Mark Signals of Interest for Control System Analysis and Design”.

responsetime

Target response time, specified as a positive scalar value. The tracking bandwidth is given by $\omega_c = 2/\text{responsetime}$. Express the target response time in the time units of the models to be tuned. For example, when tuning a model `T`, if `T.TimeUnit` is `'minutes'`, then express the target response time in minutes.

dcerror

Maximum steady-state fractional tracking error, specified as a positive scalar value. For example, `dcerror = 0.01` sets a maximum steady-state error of 1%.

If `inputname` or `outputname` are vector-valued, `dcerror` applies to all I/O pairs from `inputname` to `outputname`.

Default: 0.001

peakerror

Maximum fractional tracking error across all frequencies, specified as a positive scalar value greater than 1.

Default: 1

maxerror

Target tracking error profile as a function of frequency, specified as a SISO numeric LTI model.

`maxerror` is the maximum gain from reference signal to tracking error signal. You can specify `maxerror` as a smooth transfer function (`tf`, `zpk`, or `ss` model). Alternatively, you can sketch a piecewise error profile using an `frd` model. When you do so, the software automatically maps the error profile to a `zpk` model. The magnitude of the `zpk` model approximates the desired error profile. Use `show(Req)` to plot the magnitude of the `zpk` model.

`maxerror` must be a SISO LTI model. If `inputname` or `outputname` are cell arrays, `maxerror` applies to all I/O pairs from `inputname` to `outputname`.

If you are tuning in discrete time (that is, using a `genss` model or `sITuner` interface with nonzero `Ts`), you can specify `maxerror` as a discrete-time model with the same `Ts`. If you specify `maxerror` in continuous time, the tuning software discretizes it. Specifying the error profile in discrete time gives you more control over the error profile near the Nyquist frequency.

Properties**MaxError**

Maximum error as a function of frequency, expressed as a SISO `zpk` model. This property stores the maximum tracking error as a function of frequency (maximum gain from reference signal to tracking error signal).

If you use the syntax `Req = TuningGoal.Tracking(inputname,outputname,maxerror)`, then the `MaxError` property is the `zpk` equivalent or approximation of the LTI model you supplied as the `maxerror` input argument.

If you use the syntax `Req = TuningGoal.Tracking(inputname,outputname,resptime,dcerror,peakerror)`, then the `MaxError` is a `zpk` transfer function given by:

$$\text{MaxError} = \frac{(\text{PeakError})s + \omega_c(\text{DCError})}{s + \omega_c}.$$

MaxError is a SISO LTI model. If `inputname` or `outputname` are cell arrays, MaxError applies to all I/O pairs from `inputname` to `outputname`.

Use `show(Req)` to plot the magnitude of MaxError.

Focus

Frequency band in which tuning goal is enforced, specified as a row vector of the form `[min,max]`.

Set the `Focus` property to limit enforcement of the tuning goal to a particular frequency band. Express this value in the frequency units of the control system model you are tuning (`rad/TimeUnit`). For example, suppose `Req` is a tuning goal that you want to apply only between 1 and 100 rad/s. To restrict the tuning goal to this band, use the following command:

```
Req.Focus = [1,100];
```

Default: `[0,Inf]` for continuous time; `[0,pi/Ts]` for discrete time, where `Ts` is the model sample time.

InputScaling

Reference signal scaling, specified as a vector of positive real values.

For a MIMO tracking requirement, when the choice of units results in a mix of small and large signals in different channels of the response, use this property to specify the relative amplitude of each entry in the vector-valued step input. This information is used to scale the off-diagonal terms in the transfer function from reference to tracking error. This scaling ensures that cross-couplings are measured relative to the amplitude of each reference signal.

For example, suppose that `Req` is a tuning goal that signals `{'y1','y2'}` track reference signals `{'r1','r2'}`. Suppose further that you require the outputs to track the references with less than 10% cross-coupling. If `r1` and `r2` have comparable amplitudes, then it is sufficient to keep the gains from `r1` to `y2` and `r2` and `y1` below 0.1. However, if `r1` is 100 times larger than `r2`, the gain from `r1` to `y2` must be less than 0.001 to ensure that `r1` changes `y2` by less than 10% of the `r2` target. To ensure this result, set the `InputScaling` property as follows.

```
Req.InputScaling = [100,1];
```

This tells the software to take into account that the first reference signal is 100 times greater than the second reference signal.

The default value, `[]`, means no scaling.

Default: `[]`

Input

Reference signal names, specified as a character vector or cell array of character vectors specifying the names of the signals to be tracked, populated by the `inputname` argument.

Output

Output signal names, specified as a character vector or cell array of character vectors specifying the names of the signals that must track the reference signals, populated by the `outputname` argument.

Models

Models to which the tuning goal applies, specified as a vector of indices.

Use the `Models` property when tuning an array of control system models with `systune`, to enforce a tuning goal for a subset of models in the array. For example, suppose you want to apply the tuning goal, `Req`, to the second, third, and fourth models in a model array passed to `systune`. To restrict enforcement of the tuning goal, use the following command:

```
Req.Models = 2:4;
```

When `Models = NaN`, the tuning goal applies to all models.

Default: NaN

Openings

Feedback loops to open when evaluating the tuning goal, specified as a cell array of character vectors that identify loop-opening locations. The tuning goal is evaluated against the open-loop configuration created by opening feedback loops at the locations you identify.

If you are using the tuning goal to tune a Simulink model of a control system, then `Openings` can include any linear analysis point marked in the model, or any linear analysis point in an `sLTuner` interface associated with the Simulink model. Use `addPoint` to add analysis points and loop openings to the `sLTuner` interface. Use `getPoints` to get the list of analysis points available in an `sLTuner` interface to your model.

If you are using the tuning goal to tune a generalized state-space (`genss`) model of a control system, then `Openings` can include any `AnalysisPoint` location in the control system model. Use `getPoints` to get the list of analysis points available in the `genss` model.

For example, if `Openings = {'u1', 'u2'}`, then the tuning goal is evaluated with loops open at analysis points `u1` and `u2`.

Default: {}

Name

Name of the tuning goal, specified as a character vector.

For example, if `Req` is a tuning goal:

```
Req.Name = 'LoopReq';
```

Default: []

Examples**Tracking Goal With Response Time and Maximum Steady-State Tracking Error**

Create a tracking goal specifying that a signal `'theta'` track a signal `'theta_ref'`. The required response time is 2, in the time units of the control system you are tuning. The maximum steady-state error is 0.1%.

```
Req = TuningGoal.Tracking('theta_ref','theta',2,0.001);
```

Since `peakerror` is unspecified, this tuning goal uses the default value, 1.

Tracking Goal With Maximum Tracking Error as a Function of Frequency

Create a tracking goal specifying that a signal `'theta'` track a signal `'theta_ref'`. The maximum relative error is 0.01 (1%) in the frequency range `[0,1]`. The relative error increases to 1 (100%) at the frequency 100.

Use an `frd` model to specify the error profile as a function of frequency.

```
err = frd([0.01 0.01 1],[0 1 100]);
Req = TuningGoal.Tracking('theta_ref','theta',err);
```

The software converts `err` into a smooth function of frequency that approximates the piecewise specified profile. Display this function using `viewGoal`.

```
viewGoal(Req)
```

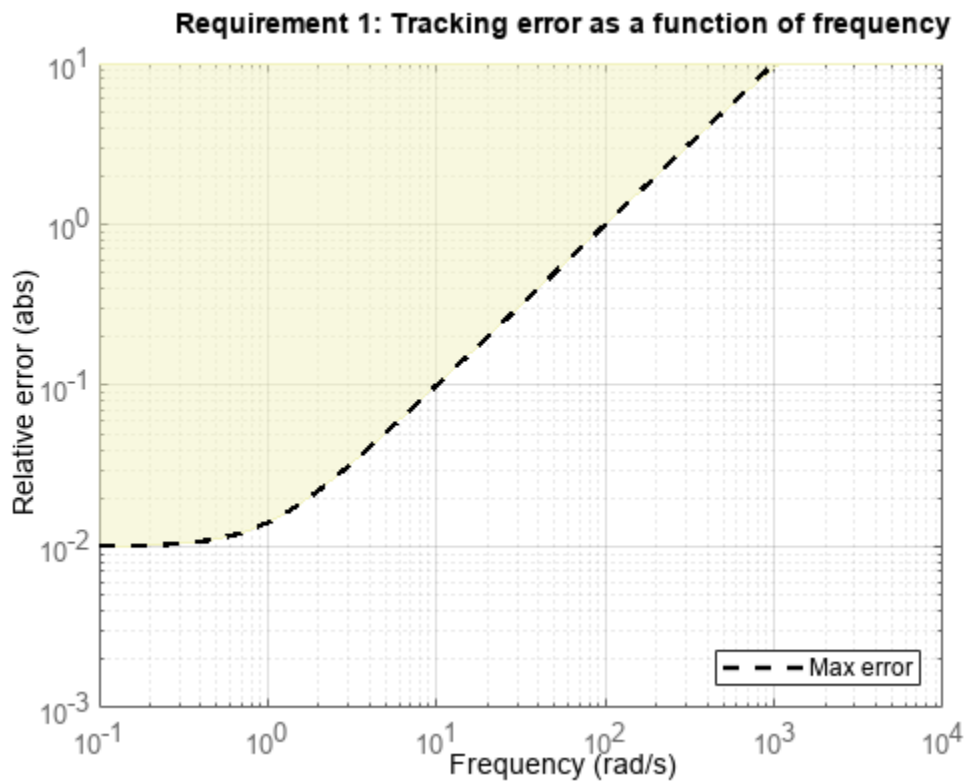

The dashed line is the target error profile stored in `MaxError`, and the shaded region indicates where the tuning goal is violated.

Tips

- This tuning goal imposes an implicit stability constraint on the closed-loop transfer function from Input to Output, evaluated with loops opened at the points identified in `Openings`. The

dynamics affected by this implicit constraint are the stabilized dynamics for this tuning goal. The `MinDecay` and `MaxRadius` options of `systemOptions` control the bounds on these implicitly constrained dynamics. If the optimization fails to meet the default bounds, or if the default bounds conflict with other requirements, use `systemOptions` to change these defaults.

Algorithms

When you tune a control system using a `TuningGoal`, the software converts the tuning goal into a normalized scalar value $f(x)$, where x is the vector of free (tunable) parameters in the control system. The software then adjusts the parameter values to minimize $f(x)$ or to drive $f(x)$ below 1 if the tuning goal is a hard constraint.

For `TuningGoal.Tracking`, $f(x)$ is given by:

$$f(x) = \|W_F(s)(T(s, x) - I)\|_{\infty},$$

or its discrete-time equivalent. Here, $T(s, x)$ is the closed-loop transfer function from `Input` to `Output`, and $\|\cdot\|_{\infty}$ denotes the H_{∞} norm (see `getPeakGain`). W_F is a frequency weighting function derived from the error profile you specify in the tuning goal. The gains of W_F and `1/MaxError` roughly match for gain values between -20 dB and 60 dB. For numerical reasons, the weighting function levels off outside this range, unless you specify a reference model that changes slope outside this range. This adjustment is called regularization. Because poles of W_F close to $s = 0$ or $s = \text{Inf}$ might lead to poor numeric conditioning of the `system` optimization problem, it is not recommended to specify error profiles with very low-frequency or very high-frequency dynamics.

To obtain W_F , use:

```
WF = getWeight(Req, Ts)
```

where `Req` is the tuning goal, and `Ts` is the sample time at which you are tuning (`Ts = 0` for continuous time). For more information about regularization and its effects, see “Visualize Tuning Goals”.

Version History

Introduced in R2016a

Functionality moved from Robust Control Toolbox

Behavior changed in R2016a

Prior to R2016a, this functionality required a Robust Control Toolbox license.

See Also

`looptune` | `system` | `system` (for `slTuner`) | `looptune` (for `slTuner`) | `viewGoal` | `evalGoal` | `TuningGoal.Gain` | `TuningGoal.LoopShape` | `slTuner`

Topics

“Time-Domain Specifications”

“Visualize Tuning Goals”

“Tune Control Systems with SYSTUNE”

“Tune Control Systems in Simulink”

“PID Tuning for Setpoint Tracking vs. Disturbance Rejection”

“Decoupling Controller for a Distillation Column”
“Digital Control of Power Stage Voltage”
“Tuning of a Two-Loop Autopilot”

TuningGoal.Transient class

Package: TuningGoal

Transient matching requirement for control system tuning

Description

Use the `TuningGoal.Transient` object to constrain the transient response from specified inputs to specified outputs. This tuning goal specifies that the transient response closely match the response of a reference model. Specify the closeness of the required match using the `RelGap` property of the tuning goal (see “Properties” on page 1-131). You can constrain the response to an impulse, step, or ramp input signal. You can also constrain the response to an input signal given by the impulse response of an input filter you specify.

Construction

`Req = TuningGoal.Transient(inputname,outputname,refsys)` requires that the impulse response from `inputname` to `outputname` closely matches the impulse response of the reference model `refsys`. Specify the closeness of the required match using the `RelGap` property of the tuning goal (see “Properties” on page 1-131). `inputname` and `outputname` can describe a SISO or MIMO response of your control system. For MIMO responses, the number of inputs must equal the number of outputs.

`Req = TuningGoal.Transient(inputname,outputname,refsys,inputtype)` specifies whether the input signal that generates the constrained transient response is an impulse, step, or ramp signal.

`Req = TuningGoal.Transient(inputname,outputname,refsys,inputfilter)` specifies the input signal for generating the transient response that the tuning goal constrains. Specify the input signal as a SISO transfer function, `inputfilter`, that is the Laplace transform of the desired time-domain input signal. The impulse response of `inputfilter` is the desired input signal.

Input Arguments

`inputname`

Input signals for the tuning goal, specified as a character vector or, for multiple-input tuning goals, a cell array of character vectors.

- If you are using the tuning goal to tune a Simulink model of a control system, then `inputname` can include:
 - Any model input.
 - Any linear analysis point marked in the model.
 - Any linear analysis point in an `sITuner` interface associated with the Simulink model. Use `addPoint` to add analysis points to the `sITuner` interface. Use `getPoints` to get the list of analysis points available in an `sITuner` interface to your model.

For example, suppose that the `sLTuner` interface contains analysis points `u1` and `u2`. Use `'u1'` to designate that point as an input signal when creating tuning goals. Use `{'u1', 'u2'}` to designate a two-channel input.

- If you are using the tuning goal to tune a generalized state-space (`genss`) model of a control system, then `inputname` can include:
 - Any input of the `genss` model
 - Any `AnalysisPoint` location in the control system model

For example, if you are tuning a control system model, `T`, then `inputname` can be any input name in `T.InputName`. Also, if `T` contains an `AnalysisPoint` block with a location named `AP_u`, then `inputname` can include `'AP_u'`. Use `getPoints` to get a list of analysis points available in a `genss` model.

If `inputname` is an `AnalysisPoint` location of a generalized model, the input signal for the tuning goal is the implied input associated with the `AnalysisPoint` block:



For more information about analysis points in control system models, see “Mark Signals of Interest for Control System Analysis and Design”.

outputname

Output signals for the tuning goal, specified as a character vector or, for multiple-output tuning goals, a cell array of character vectors.

- If you are using the tuning goal to tune a Simulink model of a control system, then `outputname` can include:
 - Any model output.
 - Any linear analysis point marked in the model.
 - Any linear analysis point in an `sLTuner` interface associated with the Simulink model. Use `addPoint` to add analysis points to the `sLTuner` interface. Use `getPoints` to get the list of analysis points available in an `sLTuner` interface to your model.

For example, suppose that the `sLTuner` interface contains analysis points `y1` and `y2`. Use `'y1'` to designate that point as an output signal when creating tuning goals. Use `{'y1', 'y2'}` to designate a two-channel output.

- If you are using the tuning goal to tune a generalized state-space (`genss`) model of a control system, then `outputname` can include:
 - Any output of the `genss` model
 - Any `AnalysisPoint` location in the control system model

For example, if you are tuning a control system model, `T`, then `outputname` can be any output name in `T.OutputName`. Also, if `T` contains an `AnalysisPoint` block with a location named

AP_u, then outputname can include 'AP_u'. Use `getPoints` to get a list of analysis points available in a `genss` model.

If outputname is an `AnalysisPoint` location of a generalized model, the output signal for the tuning goal is the implied output associated with the `AnalysisPoint` block:



For more information about analysis points in control system models, see “Mark Signals of Interest for Control System Analysis and Design”.

refsys

Reference system for target transient response, specified as a dynamic system model, such as a `tf`, `zpk`, or `ss` model. The desired transient response is the response of this model to the input signal specified by `inputtype` or `inputfilter`. The reference model must be stable, and the series connection of the reference model with the input shaping filter must have no feedthrough term.

inputtype

Type of input signal that generates the constrained transient response, specified as one of the following values:

- 'impulse' — Constrain the response at `outputname` to a unit impulse applied at `inputname`.
- 'step' — Constrain the response to a unit step. Using 'step' is equivalent to using the `TuningGoal.StepTracking` design goal.
- 'ramp' — Constrain the response to a unit ramp, $u = t$.

Default: 'impulse'

inputfilter

Custom input signal for generating the transient response, specified as a SISO transfer function (`tf` or `zpk`) model that represents the Laplace transform of the desired input signal. `inputfilter` must be continuous, and can have no poles in the open right-half plane.

The frequency response of `inputfilter` gives the signal spectrum of the desired input signal, and the impulse response of `inputfilter` is the time-domain input signal.

For example, to constrain the transient response to a unit-amplitude sine wave of frequency w , set `inputfilter` to `tf(w, [1, 0, w^2])`. This transfer function is the Laplace transform of $\sin(wt)$.

The series connection of `refsys` with `inputfilter` must have no feedthrough term.

Properties

ReferenceModel

Reference system for target transient response, specified as a SISO or MIMO state-space (`ss`) model. When you use the tuning goal to tune a control system, the transient response from `inputname` to

`outputname` is tuned to match this target response to within the tolerance specified by the `RelGap` property.

The `refsys` argument to `TuningGoal.Transient` sets the value of `ReferenceModel` to `ss(refsys)`.

InputShaping

Input signal for generating the transient response, specified as a SISO zpk model that represents the Laplace transform of the time-domain input signal. `InputShaping` must be continuous, and can have no poles in the open right-half plane. The value of this property is populated using the `inputtype` or `inputfilter` arguments used when creating the tuning goal.

For tuning goals created using the `inputtype` argument, `InputShaping` takes the following values:

<code>inputtype</code>	<code>InputShaping</code>
'impulse'	1
'step'	1/s
'ramp'	1/s ²

For tuning goals created using an `inputfilter` transfer function, `InputShaping` takes the value `zpk(inputfilter)`.

The series connection of `ReferenceModel` with `InputShaping` must have no feedthrough term.

Default: 1

RelGap

Maximum relative matching error, specified as a positive scalar value. This property specifies the matching tolerance as the maximum relative gap between the target and actual transient responses. The relative gap is defined as:

$$\text{gap} = \frac{\|y(t) - y_{ref}(t)\|_2}{\|y_{ref(tr)}(t)\|_2}.$$

$y(t) - y_{ref}(t)$ is the response mismatch, and $1 - y_{ref(tr)}(t)$ is the transient portion of y_{ref} (deviation from steady-state value or trajectory). $\|\cdot\|_2$ denotes the signal energy (2-norm). The gap can be understood as the ratio of the root-mean-square (RMS) of the mismatch to the RMS of the reference transient

Increase the value of `RelGap` to loosen the matching tolerance.

Default: 0.1

InputScaling

Input signal scaling, specified as a vector of positive real values.

Use this property to specify the relative amplitude of each entry in vector-valued input signals when the choice of units results in a mix of small and large signals. This information is used to scale the closed-loop transfer function from `Input` to `Output` when the tuning goal is evaluated.

Suppose $T(s)$ is the closed-loop transfer function from **Input** to **Output**. The tuning goal is evaluated for the scaled transfer function $D_o^{-1}T(s)D_i$. The diagonal matrices D_o and D_i have the **OutputScaling** and **InputScaling** values on the diagonal, respectively.

The default value, `[]`, means no scaling.

Default: `[]`

OutputScaling

Output signal scaling, specified as a vector of positive real values.

Use this property to specify the relative amplitude of each entry in vector-valued output signals when the choice of units results in a mix of small and large signals. This information is used to scale the closed-loop transfer function from **Input** to **Output** when the tuning goal is evaluated.

Suppose $T(s)$ is the closed-loop transfer function from **Input** to **Output**. The tuning goal is evaluated for the scaled transfer function $D_o^{-1}T(s)D_i$. The diagonal matrices D_o and D_i have the **OutputScaling** and **InputScaling** values on the diagonal, respectively.

The default value, `[]`, means no scaling.

Default: `[]`

Input

Input signal names, specified as a cell array of character vectors that indicate the inputs for the transient responses that the tuning goal constrains. The initial value of the **Input** property is populated by the `inputname` argument when you create the tuning goal.

Output

Output signal names, specified as a cell array of character vectors that indicate the outputs where transient responses that the tuning goal constrains are measured. The initial value of the **Output** property is populated by the `outputname` argument when you create the tuning goal.

Models

Models to which the tuning goal applies, specified as a vector of indices.

Use the **Models** property when tuning an array of control system models with `systeme`, to enforce a tuning goal for a subset of models in the array. For example, suppose you want to apply the tuning goal, `Req`, to the second, third, and fourth models in a model array passed to `systeme`. To restrict enforcement of the tuning goal, use the following command:

```
Req.Models = 2:4;
```

When `Models = NaN`, the tuning goal applies to all models.

Default: `NaN`

Openings

Feedback loops to open when evaluating the tuning goal, specified as a cell array of character vectors that identify loop-opening locations. The tuning goal is evaluated against the open-loop configuration created by opening feedback loops at the locations you identify.

If you are using the tuning goal to tune a Simulink model of a control system, then `Openings` can include any linear analysis point marked in the model, or any linear analysis point in an `sLTuner` interface associated with the Simulink model. Use `addPoint` to add analysis points and loop openings to the `sLTuner` interface. Use `getPoints` to get the list of analysis points available in an `sLTuner` interface to your model.

If you are using the tuning goal to tune a generalized state-space (`genss`) model of a control system, then `Openings` can include any `AnalysisPoint` location in the control system model. Use `getPoints` to get the list of analysis points available in the `genss` model.

For example, if `Openings = {'u1', 'u2'}`, then the tuning goal is evaluated with loops open at analysis points `u1` and `u2`.

Default: `{}`

Name

Name of the tuning goal, specified as a character vector.

For example, if `Req` is a tuning goal:

```
Req.Name = 'LoopReq';
```

Default: `[]`

Examples

Transient Response Requirement with Specified Input Type and Tolerance

Create a requirement for the transient response from a signal named `'r'` to a signal named `'u'`. Constrain the impulse response to match the response of transfer function $refsys = 1/(s + 1)$, but allow 20% relative variation between the target and tuned responses.

```
refsys = tf(1,[1 1]);  
Req1 = TuningGoal.Transient('r','u',refsys);
```

When you do not specify a response type, the requirement constrains the transient response. By default, the requirement allows a relative gap of 0.1 between the target and tuned responses. To change the relative gap to 20%, set the `RelGap` property of the requirement.

```
Req1.RelGap = 0.2;
```

Examine the requirement.

```
viewGoal(Req1)
```

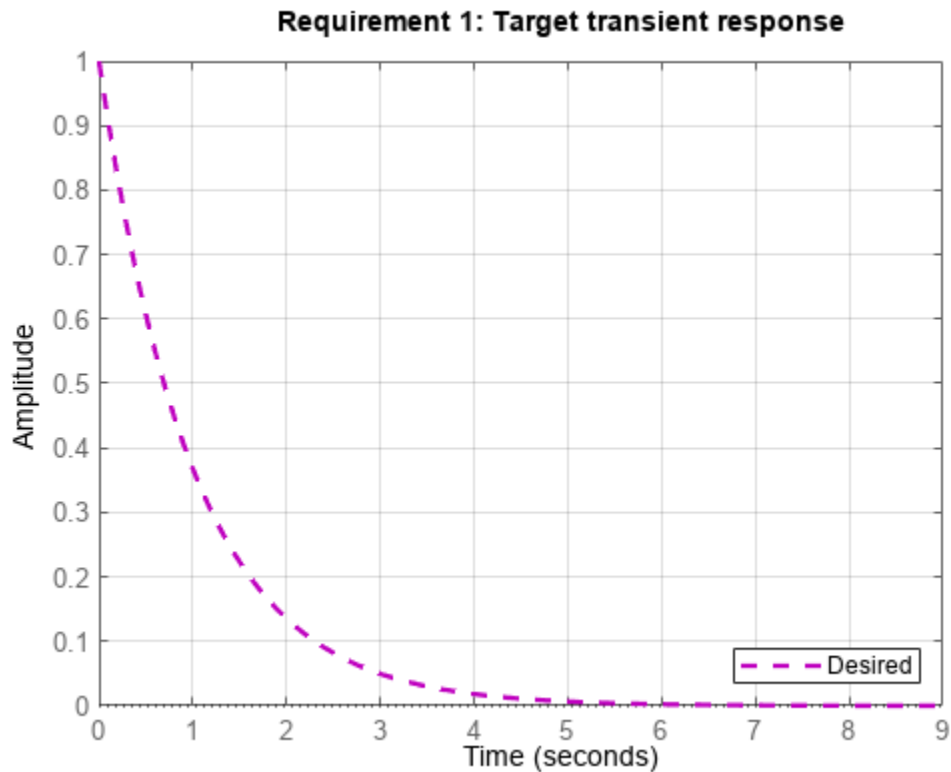
The dashed line shows the target impulse response specified by this requirement. You can use this requirement to tune a control system model, T , that contains valid input and output locations named 'r' and 'u'. If you do so, the command `viewGoal(Req1,T)` plots the achieved impulse response from 'r' to 'u' for comparison to the target response.

Create a requirement that constrains the response to a step input, instead of the impulse response.

```
Req2 = TuningGoal.Transient('r','u',refsys,'step');
```

Examine this requirement.

```
viewGoal(Req2)
```

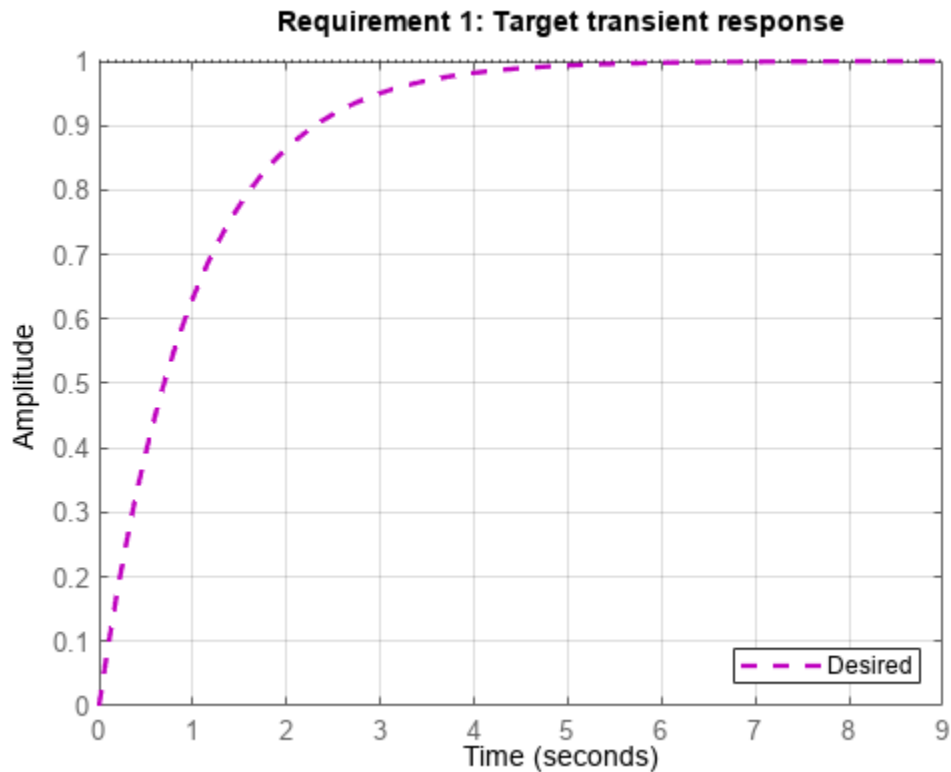

Req2 is equivalent to the following step tracking requirement:

```
Req3 = TuningGoal.StepTracking('r','u',refsys);
```

Constrain Transient Response to Custom Input Signal

Create a requirement for the transient response from 'r' to 'u'. Constrain the response to a sinusoidal input signal, rather than to an input, step, or ramp.

To specify a custom input signal, set the input filter to the Laplace transform of the desired signal. For example, suppose you want to constrain the response to a signal of $\sin\omega t$. The Laplace transform of this signal is given by:

$$\text{inputfilter} = \frac{\omega}{s^2 + \omega^2}.$$

Create a requirement that constrains the response at 'u' to a sinusoidal input of natural frequency 2 rad/s at 'r'. The response should match that of the reference system $\text{refsys} = 1/(s + 1)$.

```
refsys = tf(1,[1 1]);
w = 2;
inputfilter = tf(w,[1 0 w^2]);
Req = TuningGoal.Transient('u','r',refsys,inputfilter);
```

Examine the requirement to see the shape of the target response.

```
viewGoal(Req)
```

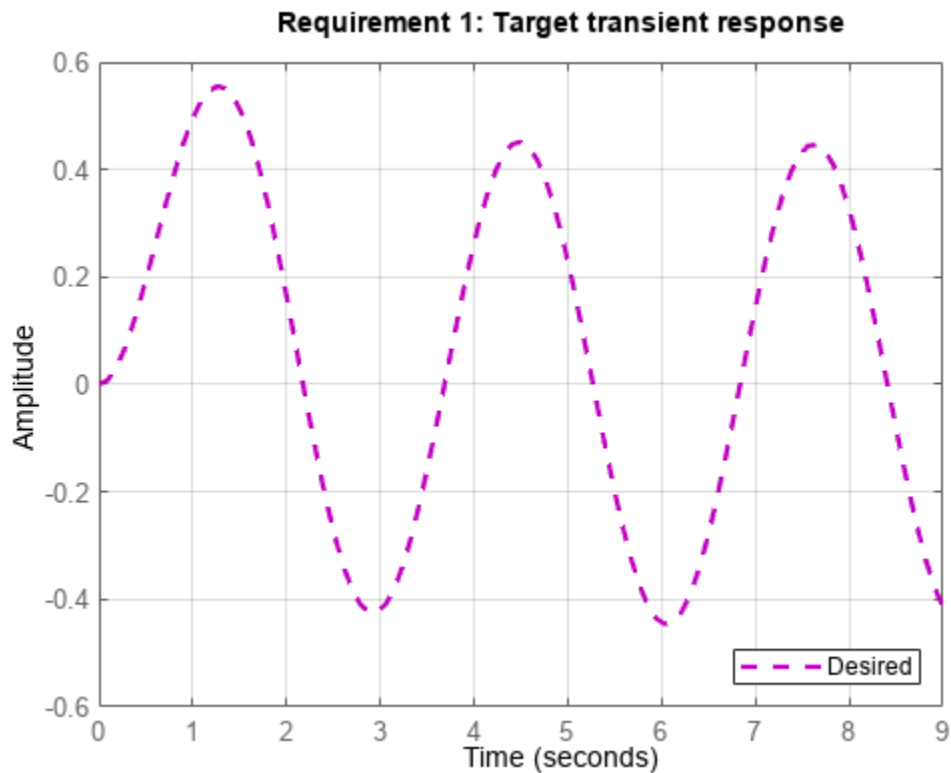

Transient Response Goal with Limited Model Application and Additional Loop Openings

Create a tuning goal that constrains the impulse response. Set the `Models` and `Openings` properties to further configure the tuning goal's applicability.

```
refsys = tf(1,[1 1]);
Req = TuningGoal.Transient('r','u',refsys);
Req.Models = [2 3];
Req.Openings = 'OuterLoop'
```

When tuning a control system that has an input (or analysis point) 'r', an output (or analysis point) 'u', and another analysis point at location 'OuterLoop', you can use `Req` as an input to `looptune` or `systemtune`. Setting the `Openings` property specifies that the impulse response from 'r' to 'y' is computed with the loop opened at 'OuterLoop'. When tuning an array of control system models, setting the `Models` property restricts how the tuning goal is applied. In this example, the tuning goal applies only to the second and third models in an array.

Tips

- When you use this tuning goal to tune a continuous-time control system, `systemtune` attempts to enforce zero feedthrough ($D = 0$) on the transfer that the tuning goal constrains. Zero feedthrough is imposed because the H_2 norm, and therefore the value of the tuning goal (see "Algorithms" on page 1-138), is infinite for continuous-time systems with nonzero feedthrough.

`system` enforces zero feedthrough by fixing to zero all tunable parameters that contribute to the feedthrough term. `system` returns an error when fixing these tunable parameters is insufficient to enforce zero feedthrough. In such cases, you must modify the tuning goal or the control structure, or manually fix some tunable parameters of your system to values that eliminate the feedthrough term.

When the constrained transfer function has several tunable blocks in series, the software's approach of zeroing all parameters that contribute to the overall feedthrough might be conservative. In that case, it is sufficient to zero the feedthrough term of one of the blocks. If you want to control which block has feedthrough fixed to zero, you can manually fix the feedthrough of the tuned block of your choice.

To fix parameters of tunable blocks to specified values, use the `Value` and `Free` properties of the block parametrization. For example, consider a tuned state-space block:

```
C = tunableSS('C',1,2,3);
```

To enforce zero feedthrough on this block, set its D matrix value to zero, and fix the parameter.

```
C.D.Value = 0;
C.D.Free = false;
```

For more information on fixing parameter values, see the Control Design Block reference pages, such as `tunableSS`.

- This tuning goal imposes an implicit stability constraint on the closed-loop transfer function from `Input` to `Output`, evaluated with loops opened at the points identified in `Openings`. The dynamics affected by this implicit constraint are the stabilized dynamics for this tuning goal. The `MinDecay` and `MaxRadius` options of `systemOptions` control the bounds on these implicitly constrained dynamics. If the optimization fails to meet the default bounds, or if the default bounds conflict with other requirements, use `systemOptions` to change these defaults.

Algorithms

When you tune a control system using a `TuningGoal`, the software converts the tuning goal into a normalized scalar value $f(x)$, where x is the vector of free (tunable) parameters in the control system. The software then adjusts the parameter values to minimize $f(x)$ or to drive $f(x)$ below 1 if the tuning goal is a hard constraint.

For `TuningGoal.Transient`, $f(x)$ is based upon the relative gap between the tuned response and the target response:

$$\text{gap} = \frac{\|y(t) - y_{ref}(t)\|_2}{\|y_{ref(tr)}(t)\|_2}.$$

$y(t) - y_{ref}(t)$ is the response mismatch, and $1 - y_{ref(tr)}(t)$ is the transient portion of y_{ref} (deviation from steady-state value or trajectory). $\|\cdot\|_2$ denotes the signal energy (2-norm). The gap can be understood as the ratio of the root-mean-square (RMS) of the mismatch to the RMS of the reference transient

Version History

Introduced in R2016a

Functionality moved from Robust Control Toolbox

Behavior changed in R2016a

Prior to R2016a, this functionality required a Robust Control Toolbox license.

See Also

[looptune](#) | [systune](#) | [systune \(for sLTuner\)](#) | [looptune \(for sLTuner\)](#) | [viewGoal](#) | [evalGoal](#) | [TuningGoal.StepTracking](#) | [TuningGoal.StepRejection](#) | [sLTuner](#)

Topics

“Time-Domain Specifications”

“Tune Control Systems with SYSTUNE”

“Tune Control Systems in Simulink”

TuningGoal.Variance class

Package: TuningGoal

Noise amplification constraint for control system tuning

Description

Use `TuningGoal.Variance` to specify a tuning goal that limits the noise amplification from specified inputs to outputs. The noise amplification is defined as either:

- The square root of the output variance, for a unit-variance white-noise input
- The root-mean-square of the output, for a unit-variance white-noise input
- The H_2 norm of the transfer function from the specified inputs to outputs, which equals the total energy of the impulse response

These definitions are different interpretations of the same quantity. `TuningGoal.Variance` imposes the same limit on these quantities.

You can use `TuningGoal.Variance` for control system tuning with tuning commands, such as `sys tune` or `looptune`. Specifying this tuning goal allows you to tune the system response to white-noise inputs. For stochastic inputs with a nonuniform spectrum (colored noise), use `TuningGoal.WeightedVariance` instead.

After you create a tuning goal, you can further configure the tuning goal by setting “Properties” on page 1-142 of the object.

Construction

`Req = TuningGoal.Variance(inputname,outputname,maxamp)` creates a tuning goal that limits the noise amplification of the transfer function from `inputname` to `outputname` to the scalar value `maxamp`.

When you tune a control system in discrete time, this tuning goal assumes that the physical plant and noise process are continuous. To ensure that continuous-time and discrete-time tuning give consistent results, `maxamp` is interpreted as a constraint on the continuous-time H_2 norm. If the plant and noise processes are truly discrete and you want to constrain the discrete-time H_2 norm to the value `maxamp`, set the third input argument to `maxamp/sqrt(Ts)`, where `Ts` is the sample time of the model you are tuning.

Input Arguments

`inputname`

Input signals for the tuning goal, specified as a character vector or, for multiple-input tuning goals, a cell array of character vectors.

- If you are using the tuning goal to tune a Simulink model of a control system, then `inputname` can include:
 - Any model input.

- Any linear analysis point marked in the model.
- Any linear analysis point in an `sLTuner` interface associated with the Simulink model. Use `addPoint` to add analysis points to the `sLTuner` interface. Use `getPoints` to get the list of analysis points available in an `sLTuner` interface to your model.

For example, suppose that the `sLTuner` interface contains analysis points `u1` and `u2`. Use `'u1'` to designate that point as an input signal when creating tuning goals. Use `{'u1', 'u2'}` to designate a two-channel input.

- If you are using the tuning goal to tune a generalized state-space (`genss`) model of a control system, then `inputname` can include:
 - Any input of the `genss` model
 - Any `AnalysisPoint` location in the control system model

For example, if you are tuning a control system model, `T`, then `inputname` can be any input name in `T.InputName`. Also, if `T` contains an `AnalysisPoint` block with a location named `AP_u`, then `inputname` can include `'AP_u'`. Use `getPoints` to get a list of analysis points available in a `genss` model.

If `inputname` is an `AnalysisPoint` location of a generalized model, the input signal for the tuning goal is the implied input associated with the `AnalysisPoint` block:



For more information about analysis points in control system models, see “Mark Signals of Interest for Control System Analysis and Design”.

outputname

Output signals for the tuning goal, specified as a character vector or, for multiple-output tuning goals, a cell array of character vectors.

- If you are using the tuning goal to tune a Simulink model of a control system, then `outputname` can include:
 - Any model output.
 - Any linear analysis point marked in the model.
 - Any linear analysis point in an `sLTuner` interface associated with the Simulink model. Use `addPoint` to add analysis points to the `sLTuner` interface. Use `getPoints` to get the list of analysis points available in an `sLTuner` interface to your model.

For example, suppose that the `sLTuner` interface contains analysis points `y1` and `y2`. Use `'y1'` to designate that point as an output signal when creating tuning goals. Use `{'y1', 'y2'}` to designate a two-channel output.

- If you are using the tuning goal to tune a generalized state-space (`genss`) model of a control system, then `outputname` can include:

- Any output of the `genss` model
- Any `AnalysisPoint` location in the control system model

For example, if you are tuning a control system model, `T`, then `outputname` can be any output name in `T.OutputName`. Also, if `T` contains an `AnalysisPoint` block with a location named `AP_u`, then `outputname` can include `'AP_u'`. Use `getPoints` to get a list of analysis points available in a `genss` model.

If `outputname` is an `AnalysisPoint` location of a generalized model, the output signal for the tuning goal is the implied output associated with the `AnalysisPoint` block:



For more information about analysis points in control system models, see “Mark Signals of Interest for Control System Analysis and Design”.

maxamp

Maximum noise amplification from `inputname` to `outputname`, specified as a positive scalar value. This value specifies the maximum value of the output variance at the signals specified in `outputname`, for unit-variance white noise signal at `inputname`. This value corresponds to the maximum H_2 norm from `inputname` to `outputname`.

When you tune a control system in discrete time, this tuning goal assumes that the physical plant and noise process are continuous, and interprets `maxamp` as a bound on the continuous-time H_2 norm. This ensures that continuous-time and discrete-time tuning give consistent results. If the plant and noise processes are truly discrete, and you want to bound the discrete-time H_2 norm instead, specify the value $\text{maxamp}/\sqrt{T_s}$. T_s is the sample time of the model you are tuning.

Properties

MaxAmplification

Maximum noise amplification, specified as a positive scalar value. This property specifies the maximum value of the output variance at the signals specified in `Output`, for unit-variance white noise signal at `Input`. This value corresponds to the maximum H_2 norm from `Input` to `Output`. The initial value of `MaxAmplification` is set by the `maxamp` input argument when you construct the tuning goal.

InputScaling

Input signal scaling, specified as a vector of positive real values.

Use this property to specify the relative amplitude of each entry in vector-valued input signals when the choice of units results in a mix of small and large signals. This information is used to scale the closed-loop transfer function from `Input` to `Output` when the tuning goal is evaluated.

Suppose $T(s)$ is the closed-loop transfer function from **Input** to **Output**. The tuning goal is evaluated for the scaled transfer function $D_o^{-1}T(s)D_i$. The diagonal matrices D_o and D_i have the **OutputScaling** and **InputScaling** values on the diagonal, respectively.

The default value, `[]`, means no scaling.

Default: `[]`

OutputScaling

Output signal scaling, specified as a vector of positive real values.

Use this property to specify the relative amplitude of each entry in vector-valued output signals when the choice of units results in a mix of small and large signals. This information is used to scale the closed-loop transfer function from **Input** to **Output** when the tuning goal is evaluated.

Suppose $T(s)$ is the closed-loop transfer function from **Input** to **Output**. The tuning goal is evaluated for the scaled transfer function $D_o^{-1}T(s)D_i$. The diagonal matrices D_o and D_i have the **OutputScaling** and **InputScaling** values on the diagonal, respectively.

The default value, `[]`, means no scaling.

Default: `[]`

Input

Input signal names, specified as a cell array of character vectors that identify the inputs of the transfer function that the tuning goal constrains. The initial value of the **Input** property is set by the `inputname` input argument when you construct the tuning goal.

Output

Output signal names, specified as a cell array of character vectors that identify the outputs of the transfer function that the tuning goal constrains. The initial value of the **Output** property is set by the `outputname` input argument when you construct the tuning goal.

Models

Models to which the tuning goal applies, specified as a vector of indices.

Use the **Models** property when tuning an array of control system models with `systeme`, to enforce a tuning goal for a subset of models in the array. For example, suppose you want to apply the tuning goal, `Req`, to the second, third, and fourth models in a model array passed to `systeme`. To restrict enforcement of the tuning goal, use the following command:

```
Req.Models = 2:4;
```

When `Models = NaN`, the tuning goal applies to all models.

Default: `NaN`

Openings

Feedback loops to open when evaluating the tuning goal, specified as a cell array of character vectors that identify loop-opening locations. The tuning goal is evaluated against the open-loop configuration created by opening feedback loops at the locations you identify.

If you are using the tuning goal to tune a Simulink model of a control system, then `Openings` can include any linear analysis point marked in the model, or any linear analysis point in an `sLTuner` interface associated with the Simulink model. Use `addPoint` to add analysis points and loop openings to the `sLTuner` interface. Use `getPoints` to get the list of analysis points available in an `sLTuner` interface to your model.

If you are using the tuning goal to tune a generalized state-space (`genss`) model of a control system, then `Openings` can include any `AnalysisPoint` location in the control system model. Use `getPoints` to get the list of analysis points available in the `genss` model.

For example, if `Openings = {'u1', 'u2'}`, then the tuning goal is evaluated with loops open at analysis points `u1` and `u2`.

Default: `{}`

Name

Name of the tuning goal, specified as a character vector.

For example, if `Req` is a tuning goal:

```
Req.Name = 'LoopReq';
```

Default: `[]`

Examples

Constrain Noise Amplification Evaluated with a Loop Opening

Create a requirement that constrains the amplification of the variance from the analysis point `AP2` to the output `y` of the following control system, measured with the outer loop open.

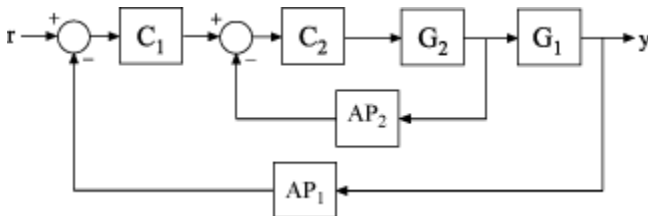

Create a model of the system. To do so, specify and connect the numeric plant models `G1` and `G2`, and the tunable controllers `C1` and `C2`. Also specify and connect the `AnalysisPoint` blocks `AP1` and `AP2` that mark points of interest for analysis and tuning.

```
G1 = tf(10,[1 10]);
G2 = tf([1 2],[1 0.2 10]);
C1 = tunablePID('C','pi');
C2 = tunableGain('G',1);
AP1 = AnalysisPoint('AP1');
AP2 = AnalysisPoint('AP2');
T = feedback(G1*feedback(G2*C2,AP2)*C1,AP1);
```

Create a tuning requirement that constrains the noise amplification from the implicit input associated with the analysis point, `AP2`, to the output `y`.

```
Req = TuningGoal.Variance('AP2', 'y', 0.1);
```

This constraint limits the amplification to a factor of 0.1.

Specify that the transfer function from AP2 to y is evaluated with the outer loop open when tuning to this constraint.

```
Req.Openings = {'AP1'};
```

Use `systemtune` to tune the free parameters of T to meet the tuning requirement specified by Req. You can then validate the tuned control system against the requirement using `viewGoal(Req, T)`.

Tips

- When you use this tuning goal to tune a continuous-time control system, `systemtune` attempts to enforce zero feedthrough ($D = 0$) on the transfer that the tuning goal constrains. Zero feedthrough is imposed because the H_2 norm, and therefore the value of the tuning goal (see “Algorithms” on page 1-145), is infinite for continuous-time systems with nonzero feedthrough.

`systemtune` enforces zero feedthrough by fixing to zero all tunable parameters that contribute to the feedthrough term. `systemtune` returns an error when fixing these tunable parameters is insufficient to enforce zero feedthrough. In such cases, you must modify the tuning goal or the control structure, or manually fix some tunable parameters of your system to values that eliminate the feedthrough term.

When the constrained transfer function has several tunable blocks in series, the software’s approach of zeroing all parameters that contribute to the overall feedthrough might be conservative. In that case, it is sufficient to zero the feedthrough term of one of the blocks. If you want to control which block has feedthrough fixed to zero, you can manually fix the feedthrough of the tuned block of your choice.

To fix parameters of tunable blocks to specified values, use the `Value` and `Free` properties of the block parametrization. For example, consider a tuned state-space block:

```
C = tunableSS('C', 1, 2, 3);
```

To enforce zero feedthrough on this block, set its D matrix value to zero, and fix the parameter.

```
C.D.Value = 0;
C.D.Free = false;
```

For more information on fixing parameter values, see the Control Design Block reference pages, such as `tunableSS`.

- This tuning goal imposes an implicit stability constraint on the closed-loop transfer function from `Input` to `Output`, evaluated with loops opened at the points identified in `Openings`. The dynamics affected by this implicit constraint are the stabilized dynamics for this tuning goal. The `MinDecay` and `MaxRadius` options of `systemtuneOptions` control the bounds on these implicitly constrained dynamics. If the optimization fails to meet the default bounds, or if the default bounds conflict with other requirements, use `systemtuneOptions` to change these defaults.

Algorithms

When you tune a control system using a `TuningGoal`, the software converts the tuning goal into a normalized scalar value $f(x)$. The vector x is the vector of free (tunable) parameters in the control

system. The software then adjusts the parameter values to minimize $f(x)$ or to drive $f(x)$ below 1 if the tuning goal is a hard constraint.

For `TuningGoal.Variance`, $f(x)$ is given by:

$$f(x) = \left\| \frac{1}{\text{MaxAmplification}} T(s, x) \right\|_2.$$

$T(s, x)$ is the closed-loop transfer function from `Input` to `Output`. $\| \cdot \|_2$ denotes the H_2 norm (see `norm`).

For tuning discrete-time control systems, $f(x)$ is given by:

$$f(x) = \left\| \frac{1}{\text{MaxAmplification} \sqrt{T_s}} T(z, x) \right\|_2.$$

T_s is the sample time of the discrete-time transfer function $T(z, x)$.

Version History

Introduced in R2016a

Functionality moved from Robust Control Toolbox

Behavior changed in R2016a

Prior to R2016a, this functionality required a Robust Control Toolbox license.

See Also

`looptune` | `sys tune` | `looptune` (for `slTuner`) | `sys tune` (for `slTuner`) | `slTuner` | `viewGoal` | `evalGoal` | `norm` | `TuningGoal.WeightedVariance`

Topics

“Frequency-Domain Specifications”

“Active Vibration Control in Three-Story Building”

“Fault-Tolerant Control of a Passenger Jet”

TuningGoal.WeightedPassivity class

Package: TuningGoal

Frequency-weighted passivity constraint

Description

A system is passive if all its I/O trajectories $(u(t),y(t))$ satisfy:

$$\int_0^T y(t)^T u(t) dt > 0,$$

for all $T > 0$. TuningGoal.WeightedPassivity enforces the passivity of the transfer function:

$$H(s) = W_L(s)T(s)W_R(s),$$

where T_s is a closed-loop response in the control system being tuned. W_L and W_R are weighting functions used to emphasize particular frequency bands. Use TuningGoal.WeightedPassivity with control system tuning commands such as systune.

Construction

`Req = TuningGoal.WeightedPassivity(inputname,outputname,WL,WR)` creates a tuning goal for enforcing passivity of the transfer function:

$$H(s) = W_L(s)T(s)W_R(s),$$

where T_s is the closed-loop transfer function from the specified inputs to the specified outputs. The weights WL and WR can be matrices or LTI models.

By default, the tuning goal enforces passivity of the weighted transfer function H . You can also enforce input and output passivity indices, with a specified excess or shortage of passivity. (See `getPassiveIndex` for more information about passivity indices.) To do so, set the IPX and OPX properties of the tuning goal. See “Weighted Passivity and Input Passivity” on page 1-152.

Input Arguments

inputname

Input signals for the tuning goal, specified as a character vector or, for multiple-input tuning goals, a cell array of character vectors.

- If you are using the tuning goal to tune a Simulink model of a control system, then `inputname` can include:
 - Any model input.
 - Any linear analysis point marked in the model.
 - Any linear analysis point in an `sITuner` interface associated with the Simulink model. Use `addPoint` to add analysis points to the `sITuner` interface. Use `getPoints` to get the list of analysis points available in an `sITuner` interface to your model.

For example, suppose that the `sLTuner` interface contains analysis points `u1` and `u2`. Use `'u1'` to designate that point as an input signal when creating tuning goals. Use `{'u1', 'u2'}` to designate a two-channel input.

- If you are using the tuning goal to tune a generalized state-space (`genss`) model of a control system, then `inputname` can include:
 - Any input of the `genss` model
 - Any `AnalysisPoint` location in the control system model

For example, if you are tuning a control system model, `T`, then `inputname` can be any input name in `T.InputName`. Also, if `T` contains an `AnalysisPoint` block with a location named `AP_u`, then `inputname` can include `'AP_u'`. Use `getPoints` to get a list of analysis points available in a `genss` model.

If `inputname` is an `AnalysisPoint` location of a generalized model, the input signal for the tuning goal is the implied input associated with the `AnalysisPoint` block:



For more information about analysis points in control system models, see “Mark Signals of Interest for Control System Analysis and Design”.

outputname

Output signals for the tuning goal, specified as a character vector or, for multiple-output tuning goals, a cell array of character vectors.

- If you are using the tuning goal to tune a Simulink model of a control system, then `outputname` can include:
 - Any model output.
 - Any linear analysis point marked in the model.
 - Any linear analysis point in an `sLTuner` interface associated with the Simulink model. Use `addPoint` to add analysis points to the `sLTuner` interface. Use `getPoints` to get the list of analysis points available in an `sLTuner` interface to your model.

For example, suppose that the `sLTuner` interface contains analysis points `y1` and `y2`. Use `'y1'` to designate that point as an output signal when creating tuning goals. Use `{'y1', 'y2'}` to designate a two-channel output.

- If you are using the tuning goal to tune a generalized state-space (`genss`) model of a control system, then `outputname` can include:
 - Any output of the `genss` model
 - Any `AnalysisPoint` location in the control system model

For example, if you are tuning a control system model, `T`, then `outputname` can be any output name in `T.OutputName`. Also, if `T` contains an `AnalysisPoint` block with a location named

AP_u, then outputname can include 'AP_u'. Use `getPoints` to get a list of analysis points available in a `genss` model.

If outputname is an `AnalysisPoint` location of a generalized model, the output signal for the tuning goal is the implied output associated with the `AnalysisPoint` block:



For more information about analysis points in control system models, see “Mark Signals of Interest for Control System Analysis and Design”.

WL, WR

Input and output weighting functions, specified as scalars, matrices, or SISO or MIMO numeric LTI models.

The functions `WL` and `WR` provide the weights for the tuning goal. The tuning goal ensures passivity of the weighted transfer function:

$$H(s) = W_L(s)T(s)W_R(s),$$

where $T(s)$ is the transfer function from `inputname` to `outputname`. The function `WL` provides the weighting for the output channels of $T(s)$, and `WR` provides the weighting for the input channels. You can specify:

- Scalar weighting — use a scalar or numeric matrix.
- Frequency-dependent weighting — use a SISO or MIMO numeric LTI model. For example:

```
WL = tf(1,[1 0.01]);
WR = 10;
```

If `WL` or `WR` is a matrix or a MIMO model, then `inputname` and `outputname` must be vector signals. The dimensions of the vector signals must be such that the dimensions of $T(s)$ are commensurate with the dimensions of `WL` and `WR`. For example, if you specify `WR = diag([1 10])`, then `inputname` must include two signals. Scalar values and SISO LTI models, however, automatically expand to any input or output dimension.

If you are tuning in discrete time (that is, using a `genss` model or `sLTuner` interface with nonzero T_s), you can specify the weighting functions as discrete-time models with the same T_s . If you specify the weighting functions in continuous time, the tuning software discretizes them. Specifying the weighting functions in discrete time gives you more control over the weighting functions near the Nyquist frequency.

A value of `WL = []` or `WR = []` is interpreted as the identity.

Default: []

Properties

WL

Frequency-weighting function for the output channels of the transfer function to constrain, specified as a scalar, a matrix, or a SISO or MIMO numeric LTI model. The initial value of this property is set by the WL input argument when you construct the tuning goal.

WR

Frequency-weighting function for the input channels of the transfer function to constrain, specified as a scalar, a matrix, or a SISO or MIMO numeric LTI model. The initial value of this property is set by the WR input argument when you construct the tuning goal.

IPX

Target passivity at the inputs listed in `inputname`, specified as a scalar value. The input passivity index is defined as the largest value of ν for which the trajectories $\{u(t), y(t)\}$ of the weighted transfer function H satisfy:

$$\int_0^T y(t)^T u(t) dt > \nu \int_0^T u(t)^T u(t) dt,$$

for all $T > 0$.

By default, the tuning goal enforces strict passivity of the weighted transfer function. To enforce an input passivity index with a specified excess or shortage of passivity, set the IPX property of the tuning goal. When you do so, the tuning software:

- Ensures that the weighted response is input strictly passive when $IPX > 0$. The magnitude of IPX sets the required excess of passivity.
- Allows the weighted response to be not input strictly passive when $IPX < 0$. The magnitude of IPX sets the permitted shortage of passivity.

See “Weighted Passivity and Input Passivity” on page 1-152 for an example. See `getPassiveIndex` for more information about passivity indices.

Default: 0

OPX

Target passivity at the outputs listed in `outputname`, specified as a scalar value. The output passivity index is defined as the largest value of ρ for which the trajectories $\{u(t), y(t)\}$ of the weighted transfer function H satisfy:

$$\int_0^T y(t)^T u(t) dt > \rho \int_0^T y(t)^T y(t) dt,$$

for all $T > 0$.

By default, the tuning goal enforces strict passivity of the weighted transfer function. To enforce an output passivity index with a specified excess or shortage of passivity, set the OPX property of the tuning goal. When you do so, the tuning software:

- Ensures that the weighted response is output strictly passive when $OPX > 0$. The magnitude of IPX sets the required excess of passivity.
- Allows the weighted response to be not output strictly passive when $OPX < 0$. The magnitude of IPX sets the permitted shortage of passivity.

See “Weighted Passivity and Input Passivity” on page 1-152 for an example. See `getPassiveIndex` for more information about passivity indices.

Default: 0

Focus

Frequency band in which tuning goal is enforced, specified as a row vector of the form `[min,max]`.

Set the `Focus` property to limit enforcement of the tuning goal to a particular frequency band. Express this value in the frequency units of the control system model you are tuning (`rad/TimeUnit`). For example, suppose `Req` is a tuning goal that you want to apply only between 1 and 100 rad/s. To restrict the tuning goal to this band, use the following command:

```
Req.Focus = [1,100];
```

Default: `[0,Inf]` for continuous time; `[0,pi/Ts]` for discrete time, where T_s is the model sample time.

Input

Input signal names, specified as a cell array of character vectors. The input signal names specify the input locations for determining passivity, initially populated by the `inputname` argument.

Output

Output signal names, specified as a cell array of character vectors. The output signal names specify the output locations for determining passivity, initially populated by the `outputname` argument.

Models

Models to which the tuning goal applies, specified as a vector of indices.

Use the `Models` property when tuning an array of control system models with `systeme`, to enforce a tuning goal for a subset of models in the array. For example, suppose you want to apply the tuning goal, `Req`, to the second, third, and fourth models in a model array passed to `systeme`. To restrict enforcement of the tuning goal, use the following command:

```
Req.Models = 2:4;
```

When `Models = NaN`, the tuning goal applies to all models.

Default: NaN

Openings

Feedback loops to open when evaluating the tuning goal, specified as a cell array of character vectors that identify loop-opening locations. The tuning goal is evaluated against the open-loop configuration created by opening feedback loops at the locations you identify.

If you are using the tuning goal to tune a Simulink model of a control system, then `Openings` can include any linear analysis point marked in the model, or any linear analysis point in an `sITuner`

interface associated with the Simulink model. Use `addPoint` to add analysis points and loop openings to the `slTuner` interface. Use `getPoints` to get the list of analysis points available in an `slTuner` interface to your model.

If you are using the tuning goal to tune a generalized state-space (`genss`) model of a control system, then `Openings` can include any `AnalysisPoint` location in the control system model. Use `getPoints` to get the list of analysis points available in the `genss` model.

For example, if `Openings = {'u1', 'u2'}`, then the tuning goal is evaluated with loops open at analysis points `u1` and `u2`.

Default: `{}`

Name

Name of the tuning goal, specified as a character vector.

For example, if `Req` is a tuning goal:

```
Req.Name = 'LoopReq';
```

Default: `[]`

Examples

Weighted Passivity and Input Passivity

Create a tuning goal that enforces the passivity of the transfer function:

$$H(s) = \begin{bmatrix} 1 & 0 \\ 0 & 10 \end{bmatrix} T(s) \left(\frac{1}{s} \right),$$

where $T(s)$ is the transfer function from an input `'d'` to outputs `['y'; 'z']` in a control system model.

```
WL = tf(1,[1 0]);
WR = diag([1 10]);
TG = TuningGoal.WeightedPassivity('d',{'y','z'},WL,WR);
```

Use `TG` with `systemtune` to enforce that weighted passivity requirement.

Suppose that instead of enforcing overall passivity of the weighted transfer function H , you want to ensure that H is input strictly passive with an input feedforward passivity index of at least 0.1. To do so, set the `IPX` property of `TG`.

```
TG.IPX = 0.1;
```

Tips

- Use `viewGoal` to visualize this tuning goal. For enforcing passivity with `IPX = 0` and `OPX = 0`, `viewGoal` plots the relative passivity indices as a function of frequency (see `passiveplot`). These are the singular values of $(I - H(j\omega))(I - H(j\omega))^{-1}$. The weighted transfer function H is passive when the largest singular value is less than 1 at all frequencies.

For nonzero IPX or OPX, `viewGoal` plots the relative index as described in “Algorithms” on page 1-153.

- This tuning goal imposes an implicit minimum-phase constraint on the transfer function $H + I$, where H is the weighted closed-loop transfer function from `Input` to `Output`, evaluated with loops opened at the points identified in `Openings`. The transmission zeros of $H + I$ are the stabilized dynamics for this tuning goal. The `MinDecay` and `MaxRadius` options of `systemOptions` control the bounds on these implicitly constrained dynamics. If the optimization fails to meet the default bounds, or if the default bounds conflict with other requirements, use `systemOptions` to change these defaults.

Algorithms

When you tune a control system using a `TuningGoal`, the software converts the tuning goal into a normalized scalar value $f(x)$, where x is the vector of free (tunable) parameters in the control system. The software then adjusts the parameter values to minimize $f(x)$ or to drive $f(x)$ below 1 if the tuning goal is a hard constraint.

For `TuningGoal.WeightedPassivity`, for a closed-loop transfer function $T(s, x)$ from `inputname` to `outputname`, and the weighted transfer function $H(s, x) = WL * T(s, x) * WR$, $f(x)$ is given by:

$$f(x) = \frac{R}{1 + R/R_{\max}}, \quad R_{\max} = 10^6.$$

R is the relative sector index (see `getSectorIndex`) of $[H(s, x); I]$, for the sector represented by:

$$Q = \begin{pmatrix} 2\rho & -I \\ -I & 2\nu \end{pmatrix},$$

using the values of the `OPX` and `IPX` properties for ρ and ν , respectively. R_{\max} is fixed at 10^6 , included to avoid numerical errors for very large R .

Version History

Introduced in R2016a

See Also

`looptune` | `systemOptions` | `systemOptions` (for `slTuner`) | `looptune` (for `slTuner`) | `viewGoal` | `evalGoal` | `TuningGoal.Passivity` | `slTuner` | `getPassiveIndex` | `passiveplot`

Topics

“About Passivity and Passivity Indices”
 “Vibration Control in Flexible Beam”
 “Tune Control Systems with SYSTUNE”
 “Tune Control Systems in Simulink”

TuningGoal.WeightedGain class

Package: TuningGoal

Frequency-weighted gain constraint for control system tuning

Description

Use `TuningGoal.WeightedGain` to limit the weighted gain from specified inputs to outputs. The weighted gain is the maximum across frequency of the gain from input to output, multiplied by weighting functions that you specify. You can use the `TuningGoal.WeightedGain` tuning goal for control system tuning with tuning commands such as `systemtune` or `looptune`.

After you create a tuning goal, you can configure it further by setting “Properties” on page 1-156 of the object.

Construction

`Req = TuningGoal.WeightedGain(inputname,outputname,WL,WR)` creates a tuning goal that specifies that the closed-loop transfer function, $H(s)$, from the specified input to output meets the requirement:

$$\|W_L(s)H(s)W_R(s)\|_\infty < 1.$$

The notation $\|\cdot\|_\infty$ denotes the maximum gain across frequency (the H_∞ norm).

Input Arguments

inputname

Input signals for the tuning goal, specified as a character vector or, for multiple-input tuning goals, a cell array of character vectors.

- If you are using the tuning goal to tune a Simulink model of a control system, then `inputname` can include:
 - Any model input.
 - Any linear analysis point marked in the model.
 - Any linear analysis point in an `sLTuner` interface associated with the Simulink model. Use `addPoint` to add analysis points to the `sLTuner` interface. Use `getPoints` to get the list of analysis points available in an `sLTuner` interface to your model.

For example, suppose that the `sLTuner` interface contains analysis points `u1` and `u2`. Use `'u1'` to designate that point as an input signal when creating tuning goals. Use `{'u1','u2'}` to designate a two-channel input.

- If you are using the tuning goal to tune a generalized state-space (`genss`) model of a control system, then `inputname` can include:
 - Any input of the `genss` model
 - Any `AnalysisPoint` location in the control system model

For example, if you are tuning a control system model, `T`, then `inputname` can be any input name in `T.InputName`. Also, if `T` contains an `AnalysisPoint` block with a location named `AP_u`, then `inputname` can include `'AP_u'`. Use `getPoints` to get a list of analysis points available in a `genss` model.

If `inputname` is an `AnalysisPoint` location of a generalized model, the input signal for the tuning goal is the implied input associated with the `AnalysisPoint` block:



For more information about analysis points in control system models, see “Mark Signals of Interest for Control System Analysis and Design”.

outputname

Output signals for the tuning goal, specified as a character vector or, for multiple-output tuning goals, a cell array of character vectors.

- If you are using the tuning goal to tune a Simulink model of a control system, then `outputname` can include:
 - Any model output.
 - Any linear analysis point marked in the model.
 - Any linear analysis point in an `sITuner` interface associated with the Simulink model. Use `addPoint` to add analysis points to the `sITuner` interface. Use `getPoints` to get the list of analysis points available in an `sITuner` interface to your model.

For example, suppose that the `sITuner` interface contains analysis points `y1` and `y2`. Use `'y1'` to designate that point as an output signal when creating tuning goals. Use `{'y1', 'y2'}` to designate a two-channel output.

- If you are using the tuning goal to tune a generalized state-space (`genss`) model of a control system, then `outputname` can include:
 - Any output of the `genss` model
 - Any `AnalysisPoint` location in the control system model

For example, if you are tuning a control system model, `T`, then `outputname` can be any output name in `T.OutputName`. Also, if `T` contains an `AnalysisPoint` block with a location named `AP_u`, then `outputname` can include `'AP_u'`. Use `getPoints` to get a list of analysis points available in a `genss` model.

If `outputname` is an `AnalysisPoint` location of a generalized model, the output signal for the tuning goal is the implied output associated with the `AnalysisPoint` block:



For more information about analysis points in control system models, see “Mark Signals of Interest for Control System Analysis and Design”.

WL, WR

Frequency-weighting functions, specified as scalars, matrices, or SISO or MIMO numeric LTI models.

The functions **WL** and **WR** provide the weights for the tuning goal. The tuning goal ensures that the gain $H(s)$ from the specified input to output satisfies the inequality:

$$\|WL(s)H(s)WR(s)\|_{\infty} < 1.$$

WL provides the weighting for the output channels of $H(s)$, and **WR** provides the weighting for the input channels. You can specify scalar weights or frequency-dependent weighting. To specify a frequency-dependent weighting, use a numeric LTI model. For example:

```
WL = tf(1,[1 0.01]);  
WR = 10;
```

If you specify MIMO weighting functions, then **inputname** and **outputname** must be vector signals. The dimensions of the vector signals must be such that the dimensions of $H(s)$ are commensurate with the dimensions of **WL** and **WR**. For example, if you specify $WR = \text{diag}([1 \ 10])$, then **inputname** must include two signals. Scalar values, however, automatically expand to any input or output dimension.

If you are tuning in discrete time (that is, using a **genss** model or **sLTuner** interface with nonzero T_s), you can specify the weighting functions as discrete-time models with the same T_s . If you specify the weighting functions in continuous time, the tuning software discretizes them. Specifying the weighting functions in discrete time gives you more control over the weighting functions near the Nyquist frequency.

A value of **WL** = [] or **WR** = [] is interpreted as the identity.

Properties

WL

Frequency-weighting function for the output channels of the transfer function to constrain, specified as a scalar, a matrix, or a SISO or MIMO numeric LTI model. The initial value of this property is set by the **WL** input argument when you construct the tuning goal.

WR

Frequency-weighting function for the input channels of the transfer function to constrain, specified as a scalar, a matrix, or a SISO or MIMO numeric LTI model. The initial value of this property is set by the **WR** input argument when you construct the tuning goal.

Focus

Frequency band in which tuning goal is enforced, specified as a row vector of the form $[\text{min}, \text{max}]$.

Set the **Focus** property to limit enforcement of the tuning goal to a particular frequency band. Express this value in the frequency units of the control system model you are tuning (rad/TimeUnit). For example, suppose **Req** is a tuning goal that you want to apply only between 1 and 100 rad/s. To restrict the tuning goal to this band, use the following command:

```
Req.Focus = [1,100];
```

Default: $[0, \text{Inf}]$ for continuous time; $[0, \pi/T_s]$ for discrete time, where T_s is the model sample time.

Stabilize

Stability requirement on closed-loop dynamics, specified as 1 (`true`) or 0 (`false`).

By default, `TuningGoal.Gain` imposes a stability requirement on the closed-loop transfer function from the specified inputs to outputs, in addition to the gain requirement. If stability is not required or cannot be achieved, set `Stabilize` to `false` to remove the stability requirement. For example, if the gain constraint applies to an unstable open-loop transfer function, set `Stabilize` to `false`.

Default: 1(`true`)

Input

Input signal names, specified as a cell array of character vectors that identify the inputs of the transfer function that the tuning goal constrains. The initial value of the `Input` property is set by the `inputname` input argument when you construct the tuning goal.

Output

Output signal names, specified as a cell array of character vectors that identify the outputs of the transfer function that the tuning goal constrains. The initial value of the `Output` property is set by the `outputname` input argument when you construct the tuning goal.

Models

Models to which the tuning goal applies, specified as a vector of indices.

Use the `Models` property when tuning an array of control system models with `systemtune`, to enforce a tuning goal for a subset of models in the array. For example, suppose you want to apply the tuning goal, `Req`, to the second, third, and fourth models in a model array passed to `systemtune`. To restrict enforcement of the tuning goal, use the following command:

```
Req.Models = 2:4;
```

When `Models = NaN`, the tuning goal applies to all models.

Default: NaN

Openings

Feedback loops to open when evaluating the tuning goal, specified as a cell array of character vectors that identify loop-opening locations. The tuning goal is evaluated against the open-loop configuration created by opening feedback loops at the locations you identify.

If you are using the tuning goal to tune a Simulink model of a control system, then `Openings` can include any linear analysis point marked in the model, or any linear analysis point in an `sLTuner` interface associated with the Simulink model. Use `addPoint` to add analysis points and loop openings to the `sLTuner` interface. Use `getPoints` to get the list of analysis points available in an `sLTuner` interface to your model.

If you are using the tuning goal to tune a generalized state-space (genss) model of a control system, then `Openings` can include any `AnalysisPoint` location in the control system model. Use `getPoints` to get the list of analysis points available in the genss model.

For example, if `Openings = {'u1', 'u2'}`, then the tuning goal is evaluated with loops open at analysis points `u1` and `u2`.

Default: `{}`

Name

Name of the tuning goal, specified as a character vector.

For example, if `Req` is a tuning goal:

```
Req.Name = 'LoopReq';
```

Default: `[]`

Examples

Constrain Weighted Gain of Closed-Loop System

Create a tuning goal requirement that constrains the gain of a closed-loop SISO system from its input, r , to its output, y . Weight the gain at its input by a factor of 10 and at its output by the frequency-dependent weight $1/(s + 0.01)$.

```
WL = tf(1,[1 0.01]);
WR = 10;
Req = TuningGoal.WeightedGain('r','y',WL,WR);
```

You can use the requirement `Req` with `systemtune` to tune the free parameters of any control system model that has an input signal named `'r'` and an output signal named `'y'`.

You can then use `viewGoal` to validate the tuned control system against the requirement.

Constrain Weighted Gain Evaluated with a Loop Opening

Create a requirement that constrains the gain of the outer loop of the following control system, evaluated with the inner loop open.

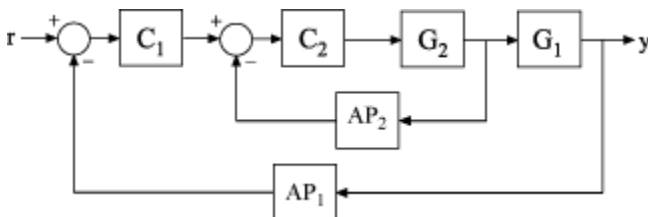

Create a model of the system. To do so, specify and connect the numeric plant models, `G1` and `G2`, the tunable controllers `C1` and `C2`. Also, create and connect the `AnalysisPoint` blocks that mark points of interest for analysis or tuning, `AP1` and `AP2`.

```

G1 = tf(10,[1 10]);
G2 = tf([1 2],[1 0.2 10]);
C1 = tunablePID('C','pi');
C2 = tunableGain('G',1);
AP1 = AnalysisPoint('AP1');
AP2 = AnalysisPoint('AP2');
T = feedback(G1*feedback(G2*C2,AP2)*C1,AP1);
T.InputName = 'r';
T.OutputName = 'y';

```

Create a tuning requirement that constrains the gain of this system from r to y . Weight the gain at the output by $s/(s + 0.5)$.

```

WL = tf([1 0],[1 0.5]);
Req = TuningGoal.WeightedGain('r','y',WL,[]);

```

This requirement is equivalent to `Req = TuningGoal.Gain('r','y',1/WL)`. However, for MIMO systems, you can use `TuningGoal.WeightedGain` to create channel-specific weightings that cannot be expressed as `TuningGoal.Gain` requirements.

Specify that the transfer function from r to y be evaluated with the outer loop open for the purpose of tuning to this constraint.

```
Req.Openings = 'AP1';
```

By default, tuning using `TuningGoal.WeightedGain` imposes a stability requirement as well as the gain requirement. Practically, in some control systems it is not possible to achieve a stable inner loop. When this occurs, remove the stability requirement for the inner loop by setting the `Stabilize` property to `false`.

```
Req.Stabilize = false;
```

The tuning algorithm still imposes a stability requirement on the overall tuned control system, but not on the inner loop alone.

Use `systune` to tune the free parameters of `T` to meet the tuning requirement specified by `Req`. You can then validate the tuned control system against the requirement using the command `viewGoal(Req,T)`.

Tips

- This tuning goal imposes an implicit stability constraint on the weighted closed-loop transfer function from `Input` to `Output`, evaluated with loops opened at the points identified in `Openings`. The dynamics affected by this implicit constraint are the stabilized dynamics for this tuning goal. The `MinDecay` and `MaxRadius` options of `systuneOptions` control the bounds on these implicitly constrained dynamics. If the optimization fails to meet the default bounds, or if the default bounds conflict with other requirements, use `systuneOptions` to change these defaults.

Algorithms

When you tune a control system using a `TuningGoal`, the software converts the tuning goal into a normalized scalar value $f(x)$. x is the vector of free (tunable) parameters in the control system. The software then adjusts the parameter values to minimize $f(x)$ or to drive $f(x)$ below 1 if the tuning goal is a hard constraint.

For `TuningGoal.WeightedGain`, $f(x)$ is given by:

$$f(x) = \|W_L T(s, x) W_R\|_\infty.$$

$T(s, x)$ is the closed-loop transfer function from Input to Output. $\|\cdot\|_\infty$ denotes the H_∞ norm (see `getPeakGain`).

Version History

Introduced in R2016a

Functionality moved from Robust Control Toolbox

Behavior changed in R2016a

Prior to R2016a, this functionality required a Robust Control Toolbox license.

See Also

`looptune` | `system` | `looptune` (for `sITuner`) | `system` (for `sITuner`) | `sITuner` | `viewGoal` | `evalGoal`

Topics

“Frequency-Domain Specifications”

TuningGoal.WeightedVariance class

Package: TuningGoal

Frequency-weighted H_2 norm constraint for control system tuning

Description

Use `TuningGoal.WeightedVariance` to limit the weighted H_2 norm of the transfer function from specified inputs to outputs. The H_2 norm measures:

- The total energy of the impulse response, for deterministic inputs to the transfer function.
- The square root of the output variance for a unit-variance white-noise input, for stochastic inputs to the transfer function. Equivalently, the H_2 norm measures the root-mean-square of the output for such input.

You can use `TuningGoal.WeightedVariance` for control system tuning with tuning commands, such as `systemtune` or `looptune`. By specifying this tuning goal, you can tune the system response to stochastic inputs with a nonuniform spectrum such as colored noise or wind gusts. You can also use `TuningGoal.WeightedVariance` to specify LQG-like performance objectives.

After you create a tuning goal object, you can configure it further by setting “Properties” on page 1-164 of the object.

Construction

`Req = TuningGoal.Variance(inputname,outputname,WL,WR)` creates a tuning goal `Req`. This tuning goal specifies that the closed-loop transfer function $H(s)$ from the specified input to output meets the requirement:

$$\|W_L(s)H(s)W_R(s)\|_2 < 1.$$

The notation $\|\bullet\|_2$ denotes the H_2 norm.

When you are tuning a discrete-time system, `Req` imposes the following constraint:

$$\frac{1}{\sqrt{T_s}} \|W_L(z)T(z,x)W_R(z)\|_2 < 1.$$

The H_2 norm is scaled by the square root of the sample time T_s to ensure consistent results with tuning in continuous time. To constrain the true discrete-time H_2 norm, multiply either W_L or W_R by $\sqrt{T_s}$.

Input Arguments

inputname

Input signals for the tuning goal, specified as a character vector or, for multiple-input tuning goals, a cell array of character vectors.

- If you are using the tuning goal to tune a Simulink model of a control system, then `inputname` can include:

- Any model input.
- Any linear analysis point marked in the model.
- Any linear analysis point in an `sLTuner` interface associated with the Simulink model. Use `addPoint` to add analysis points to the `sLTuner` interface. Use `getPoints` to get the list of analysis points available in an `sLTuner` interface to your model.

For example, suppose that the `sLTuner` interface contains analysis points `u1` and `u2`. Use `'u1'` to designate that point as an input signal when creating tuning goals. Use `{'u1', 'u2'}` to designate a two-channel input.

- If you are using the tuning goal to tune a generalized state-space (`genss`) model of a control system, then `inputname` can include:
 - Any input of the `genss` model
 - Any `AnalysisPoint` location in the control system model

For example, if you are tuning a control system model, `T`, then `inputname` can be any input name in `T`. `InputName`. Also, if `T` contains an `AnalysisPoint` block with a location named `AP_u`, then `inputname` can include `'AP_u'`. Use `getPoints` to get a list of analysis points available in a `genss` model.

If `inputname` is an `AnalysisPoint` location of a generalized model, the input signal for the tuning goal is the implied input associated with the `AnalysisPoint` block:



For more information about analysis points in control system models, see “Mark Signals of Interest for Control System Analysis and Design”.

outputname

Output signals for the tuning goal, specified as a character vector or, for multiple-output tuning goals, a cell array of character vectors.

- If you are using the tuning goal to tune a Simulink model of a control system, then `outputname` can include:
 - Any model output.
 - Any linear analysis point marked in the model.
 - Any linear analysis point in an `sLTuner` interface associated with the Simulink model. Use `addPoint` to add analysis points to the `sLTuner` interface. Use `getPoints` to get the list of analysis points available in an `sLTuner` interface to your model.

For example, suppose that the `sLTuner` interface contains analysis points `y1` and `y2`. Use `'y1'` to designate that point as an output signal when creating tuning goals. Use `{'y1', 'y2'}` to designate a two-channel output.

- If you are using the tuning goal to tune a generalized state-space (`genss`) model of a control system, then `outputname` can include:

- Any output of the `genss` model
- Any `AnalysisPoint` location in the control system model

For example, if you are tuning a control system model, `T`, then `outputname` can be any output name in `T.OutputName`. Also, if `T` contains an `AnalysisPoint` block with a location named `AP_u`, then `outputname` can include `'AP_u'`. Use `getPoints` to get a list of analysis points available in a `genss` model.

If `outputname` is an `AnalysisPoint` location of a generalized model, the output signal for the tuning goal is the implied output associated with the `AnalysisPoint` block:



For more information about analysis points in control system models, see “Mark Signals of Interest for Control System Analysis and Design”.

WL, WR

Frequency-weighting functions, specified as scalars, matrices, or SISO or MIMO numeric LTI models.

The functions `WL` and `WR` provide the weights for the tuning goal. The tuning goal ensures that the gain $H(s)$ from the specified input to output satisfies the inequality:

$$\|W_L(s)H(s)W_R(s)\|_2 < 1.$$

`WL` provides the weighting for the output channels of $H(s)$, and `WR` provides the weighting for the input channels. You can specify scalar weights or frequency-dependent weighting. To specify a frequency-dependent weighting, use a numeric LTI model. For example:

```
WL = tf(1,[1 0.01]);
WR = 10;
```

If you specify MIMO weighting functions, then `inputname` and `outputname` must be vector signals. The dimensions of the vector signals must be such that the dimensions of $H(s)$ are commensurate with the dimensions of `WL` and `WR`. For example, if you specify `WR = diag([1 10])`, then `inputname` must include two signals. Scalar values, however, automatically expand to any input or output dimension.

If you are tuning in discrete time (that is, using a `genss` model or `sITuner` interface with nonzero `Ts`), you can specify the weighting functions as discrete-time models with the same `Ts`. If you specify the weighting functions in continuous time, the tuning software discretizes them. Specifying the weighting functions in discrete time gives you more control over the weighting functions near the Nyquist frequency.

A value of `WL = []` or `WR = []` is interpreted as the identity.

Properties

WL

Frequency-weighting function for the output channels of the transfer function to constrain, specified as a scalar, a matrix, or a SISO or MIMO numeric LTI model. The initial value of this property is set by the `WL` input argument when you construct the tuning goal.

WR

Frequency-weighting function for the input channels of the transfer function to constrain, specified as a scalar, a matrix, or a SISO or MIMO numeric LTI model. The initial value of this property is set by the `WR` input argument when you construct the tuning goal.

Input

Input signal names, specified as a cell array of character vectors that identify the inputs of the transfer function that the tuning goal constrains. The initial value of the `Input` property is set by the `inputname` input argument when you construct the tuning goal.

Output

Output signal names, specified as a cell array of character vectors that identify the outputs of the transfer function that the tuning goal constrains. The initial value of the `Output` property is set by the `outputname` input argument when you construct the tuning goal.

Models

Models to which the tuning goal applies, specified as a vector of indices.

Use the `Models` property when tuning an array of control system models with `systemtune`, to enforce a tuning goal for a subset of models in the array. For example, suppose you want to apply the tuning goal, `Req`, to the second, third, and fourth models in a model array passed to `systemtune`. To restrict enforcement of the tuning goal, use the following command:

```
Req.Models = 2:4;
```

When `Models = NaN`, the tuning goal applies to all models.

Default: NaN

Openings

Feedback loops to open when evaluating the tuning goal, specified as a cell array of character vectors that identify loop-opening locations. The tuning goal is evaluated against the open-loop configuration created by opening feedback loops at the locations you identify.

If you are using the tuning goal to tune a Simulink model of a control system, then `Openings` can include any linear analysis point marked in the model, or any linear analysis point in an `sLTuner` interface associated with the Simulink model. Use `addPoint` to add analysis points and loop openings to the `sLTuner` interface. Use `getPoints` to get the list of analysis points available in an `sLTuner` interface to your model.

If you are using the tuning goal to tune a generalized state-space (`genss`) model of a control system, then `Openings` can include any `AnalysisPoint` location in the control system model. Use `getPoints` to get the list of analysis points available in the `genss` model.

For example, if `Openings = {'u1', 'u2'}`, then the tuning goal is evaluated with loops open at analysis points `u1` and `u2`.

Default: `{}`

Name

Name of the tuning goal, specified as a character vector.

For example, if `Req` is a tuning goal:

```
Req.Name = 'LoopReq';
```

Default: `[]`

Examples

Weighted Constraint on H2 Norm

Create a constraint for a transfer function with one input, `r`, and two outputs, `e` and `y`, that limits the H_2 norm as follows:

$$\left\| \begin{array}{c} \frac{1}{s+0.001} T_{re} \\ \frac{s}{0.001s+1} T_{ry} \end{array} \right\|_2 < 1.$$

T_{re} is the closed-loop transfer function from `r` to `e`, and T_{ry} is the closed-loop transfer function from `r` to `y`.

```
s = tf('s');
WL = blkdiag(1/(s+0.001), s/(0.001*s+1));
Req = TuningGoal.WeightedVariance('r', {'e', 'y'}, WL, []);
```

Tips

- When you use this tuning goal to tune a continuous-time control system, `system` attempts to enforce zero feedthrough ($D = 0$) on the transfer that the tuning goal constrains. Zero feedthrough is imposed because the H_2 norm, and therefore the value of the tuning goal (see “Algorithms” on page 1-166), is infinite for continuous-time systems with nonzero feedthrough.

`system` enforces zero feedthrough by fixing to zero all tunable parameters that contribute to the feedthrough term. `system` returns an error when fixing these tunable parameters is insufficient to enforce zero feedthrough. In such cases, you must modify the tuning goal or the control structure, or manually fix some tunable parameters of your system to values that eliminate the feedthrough term.

When the constrained transfer function has several tunable blocks in series, the software’s approach of zeroing all parameters that contribute to the overall feedthrough might be conservative. In that case, it is sufficient to zero the feedthrough term of one of the blocks. If you want to control which block has feedthrough fixed to zero, you can manually fix the feedthrough of the tuned block of your choice.

To fix parameters of tunable blocks to specified values, use the `Value` and `Free` properties of the block parametrization. For example, consider a tuned state-space block:

```
C = tunableSS('C',1,2,3);
```

To enforce zero feedthrough on this block, set its `D` matrix value to zero, and fix the parameter.

```
C.D.Value = 0;
C.D.Free = false;
```

For more information on fixing parameter values, see the Control Design Block reference pages, such as `tunableSS`.

- This tuning goal imposes an implicit stability constraint on the weighted closed-loop transfer function from `Input` to `Output`, evaluated with loops opened at the points identified in `Openings`. The dynamics affected by this implicit constraint are the stabilized dynamics for this tuning goal. The `MinDecay` and `MaxRadius` options of `systuneOptions` control the bounds on these implicitly constrained dynamics. If the optimization fails to meet the default bounds, or if the default bounds conflict with other requirements, use `systuneOptions` to change these defaults.

Algorithms

When you tune a control system using a `TuningGoal`, the software converts the tuning goal into a normalized scalar value $f(x)$. x is the vector of free (tunable) parameters in the control system. The software then adjusts the parameter values to minimize $f(x)$ or to drive $f(x)$ below 1 if the tuning goal is a hard constraint.

For `TuningGoal.WeightedVariance`, $f(x)$ is given by:

$$f(x) = \|W_L T(s, x) W_R\|_2.$$

$T(s, x)$ is the closed-loop transfer function from `Input` to `Output`. $\|\cdot\|_2$ denotes the H_2 norm (see `norm`).

For tuning discrete-time control systems, $f(x)$ is given by:

$$f(x) = \frac{1}{\sqrt{T_s}} \|W_L(z) T(z, x) W_R(z)\|_2.$$

T_s is the sample time of the discrete-time transfer function $T(z, x)$.

Version History

Introduced in R2016a

Functionality moved from Robust Control Toolbox

Behavior changed in R2016a

Prior to R2016a, this functionality required a Robust Control Toolbox license.

See Also

`systune` | `looptune` | `systune` (for `slTuner`) | `looptune` (for `slTuner`) | `TuningGoal.Gain` | `TuningGoal.LoopShape` | `slTuner` | `norm` | `TuningGoal.Variance`

Topics

“Frequency-Domain Specifications”

“Fault-Tolerant Control of a Passenger Jet”

Functions

abs

Entrywise magnitude of frequency response

Syntax

```
absfrd = abs(sys)
```

Description

`absfrd = abs(sys)` computes the magnitude of the frequency response contained in the FRD model `sys`. For MIMO models, the magnitude is computed for each entry. The output `absfrd` is an FRD object containing the magnitude data across frequencies.

Version History

Introduced in R2006a

See Also

`bodemag` | `sigma` | `fnorm`

absorbDelay

Replace time delays by poles at $z = 0$ or phase shift

Syntax

```
sysnd = absorbDelay(sysd)
[sysnd,G] = absorbDelay(sysd)
```

Description

`sysnd = absorbDelay(sysd)` absorbs all time delays of the dynamic system model `sysd` into the system dynamics or the frequency response data.

For discrete-time models (other than frequency response data models), a delay of k sampling periods is replaced by k poles at $z = 0$. For continuous-time models (other than frequency response data models), time delays have no exact representation with a finite number of poles and zeros. Therefore, use `pade` to compute a rational approximation of the time delay.

For frequency response data models in both continuous and discrete time, `absorbDelay` absorbs all time delays into the frequency response data as a phase shift.

`[sysnd,G] = absorbDelay(sysd)` returns the matrix `G` that maps the initial states of the `ss` model `sysd` to the initial states of the `sysnd`.

Examples

Absorb Time Delay into System Dynamics

Create a discrete-time transfer function that has a time delay.

```
z = tf('z',-1);
sysd = (-0.4*z - 0.1)/(z^2 + 1.05*z + 0.08);
sysd.InputDelay = 3
```

```
sysd =
```

$$z^{(-3)} * \frac{-0.4 z - 0.1}{z^2 + 1.05 z + 0.08}$$

```
Sample time: unspecified
Discrete-time transfer function.
```

The display of `sysd` represents the `InputDelay` as a factor of $z^{(-3)}$, separate from the system poles that appear in the transfer function denominator.

Absorb the time delay into the system dynamics as poles at $z = 0$.

```
sysnd = absorbDelay(sysd)
```

```

sysnd =

      -0.4 z - 0.1
-----
z^5 + 1.05 z^4 + 0.08 z^3

Sample time: unspecified
Discrete-time transfer function.

```

The display of `sysnd` shows that the factor of z^{-3} has been absorbed as additional poles in the denominator.

Verify that `sysnd` has no input delay.

```

sysnd.InputDelay

ans = 0

```

Convert Leading Structural Zeros of Polynomial Model to Regular Coefficients

Create a discrete-time polynomial model.

```
m = idpoly(1,[0 0 0 2 3]);
```

Convert `m` to a transfer function model.

```

sys = tf(m)

sys =

      z^(-2) * (2 z^-1 + 3 z^-2)

Sample time: unspecified
Discrete-time transfer function.

```

The numerator of the transfer function, `sys`, is `[0 2 3]` and the transport delay, `sys.IODelay`, is 2. This is because the value of the B polynomial, `m.B`, has 3 leading zeros. The first fixed zero shows lack of feedthrough in the model. The two zeros after that are treated as input-output delays.

Use `absorbDelay` to treat the leading zeros as regular B coefficients.

```

m2 = absorbDelay(m);
sys2 = tf(m2)

sys2 =

      2 z^-3 + 3 z^-4

Sample time: unspecified
Discrete-time transfer function.

```

The numerator of `sys2` is `[0 0 0 2 3]` and transport delay is 0. The model `m2` treats the leading zeros as regular coefficients by freeing their values. `m2.Structure.B.Free(2:3)` is TRUE while `m.Structure.B.Free(2:3)` is FALSE.

Version History

Introduced in R2011b

See Also

hasdelay | pade | totaldelay

allmargin

Gain margin, phase margin, delay margin, and crossover frequencies

Syntax

```
S = allmargin(L)
S = allmargin(mag,phase,w,ts)
```

Description

`S = allmargin(L)` computes the gain margin, phase margin, delay margin, and the corresponding crossover frequencies for the SISO or MIMO negative feedback loop with open-loop response `L`. The negative feedback loop is computed as `feedback(L, eye(M))`, where `M` is the number of inputs and outputs in `L`.

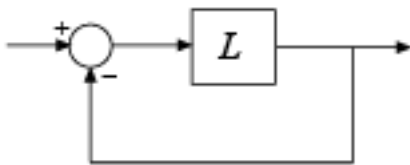

For a MIMO system, `allmargin` returns loop-at-a-time stability margins for the negative-feedback closed loop system. Use `allmargin` to find classical margins of any SISO or MIMO model, including models with delays.

`S = allmargin(mag,phase,w,ts)` computes the stability margins from the frequency response data `mag`, `phase`, `w`, and the sample time, `ts`.

Examples

Stability Margins of a Transfer Function

For this example, consider a SISO open-loop transfer function `L` given by,

$$L = \frac{25}{s^3 + 10s^2 + 10s + 10}$$

```
L = tf(25,[1 10 10 10]);
```

Find the stability margins of `L`.

```
S = allmargin(L)
```

```
S = struct with fields:
  GainMargin: 3.6000
  GMFrequency: 3.1623
  PhaseMargin: 29.1104
```



```
PMFrequency: 1.7844
DelayMargin: 0.2847
DMFrequency: 1.7844
Stable: 1
```

The output `S` is a structure with the classical margins and their respective crossover frequencies of the negative feedback loop of `L`.

Stability Margins of a MIMO System

For this example, consider a MIMO state-space model `L` with 2 inputs and 2 outputs.

Load the data.

```
load('mimoStateSpaceModel.mat','L')
```

Find the classical margins for the MIMO system.

```
S = allmargin(L)
```

```
S=2x1 struct array with fields:
  GainMargin
  GMFrequency
  PhaseMargin
  PMFrequency
  DelayMargin
  DMFrequency
  Stable
```

The output `S` is a 2-by-1 structure array of classical margins and their respective crossover frequencies. For instance, `S(1)` refers to the stability margins of the first I/O feedback channel with all other loops closed.

Stability Margins of Models in an Array

For this example, load `invertedPendulumArray.mat`, which contains a 3-by-3 array of inverted pendulum SISO models. The mass of the pendulum varies as you move from model to model along a single column of `sys`, and the length of the pendulum varies as you move along a single row. The mass values used are 100g, 200g and 300g, and the pendulum lengths used are 3m, 2m and 1m respectively.

	Column 1	Column 2	Column 3
Row 1	100g, 3m	100g, 2m	100g, 1m
Row 2	200g, 3m	200g, 2m	200g, 1m
Row 3	300g, 3m	300g, 2m	300g, 1m

```
load('invertedPendulumArray.mat','sys');
size(sys)
```

3x3 array of transfer functions.
Each model has 1 outputs and 1 inputs.

Find stability margins for all models in the array.

```
S = allmargin(sys)
```

```
S=3x3 struct array with fields:
```

```
GainMargin  
GMFrequency  
PhaseMargin  
PMFrequency  
DelayMargin  
DMFrequency  
Stable
```

`allmargin` returns a 3-by-3 structure array `S`, in which each entry is a structure containing the stability margins of the corresponding entry in `sys`. For instance, the stability margins of the model with 100g pendulum weight and 2m length is contained in `S(1,2)`.

Stability Margins from Frequency Response Data

For this example, load the frequency response data of an open loop system, consisting of magnitudes `m` and phase values `p` measured at the frequencies in `w`.

```
load('openLoopFRData.mat','m','p','w','ts');
```

Compute stability margins using the frequency response data.

```
S = allmargin(m,p,w,ts)
```

```
S = struct with fields:  
GainMargin: 0.6249  
GMFrequency: 1.2732  
PhaseMargin: [-90.0000 48.9853]  
PMFrequency: [1.0000 1.5197]  
DelayMargin: [4.7124 0.5626]  
DMFrequency: [1.0000 1.5197]  
Stable: NaN
```

The output `S` is a structure with the classical margins and their respective crossover frequencies. Since `allmargin` cannot assess the stability for frequency response data models, `S.Stable = NaN`.

Input Arguments

L — Open-loop response

dynamic system model | model array

Open-loop response, specified as a dynamic system model. `L` can be SISO or MIMO, as long as it has the same number of inputs and outputs. `allmargin` computes the classical stability margins for the negative-feedback closed-loop system `feedback(L,eye(M))`:

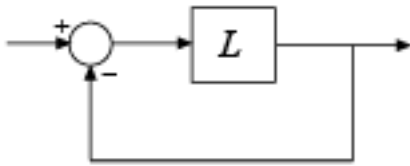

To compute the stability margins of the positive feedback system $\text{feedback}(L, \text{eye}(M), +1)$, use `allmargin(-L)`.

When you have a controller P and a plant C , you can compute the stability margins for gain and phase variations at the plant inputs or outputs. From the following diagram:

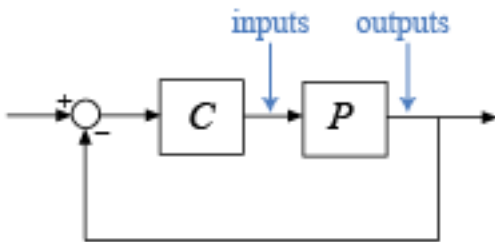

- To compute margins at the plant outputs, set $L = P*C$.
- To compute margins at the plant inputs, set $L = C*P$.

L can be continuous time or discrete time. If L is a generalized state-space model (`genss` or `uss`), then `allmargin` uses the current or nominal value of all control design blocks in L .

If L is a frequency-response data model (such as `frd`), then `allmargin` computes the margins at each frequency represented in the model. The function returns the margins at the frequency with the smallest stability margin.

If L is a model array, then `allmargin` computes margins for each model in the array.

mag — Magnitude of system response

3-D array

Magnitude of the system response in absolute units, specified as a 3-D array. `mag` is an M -by- M -by- N array, where M is the number of inputs or outputs, and N is the number of frequency points. For more information on obtaining `mag`, see “Obtain Magnitude and Phase Data” on page 2-66 and “Magnitude and Phase of MIMO System” on page 2-67.

phase — Phase of system response

3-D array

Phase of the system response in degrees, specified as a 3-D array. `phase` is an M -by- M -by- N array, where M is the number of inputs or outputs, and N is the number of frequency points. For more information on obtaining `phase`, see “Obtain Magnitude and Phase Data” on page 2-66 and “Magnitude and Phase of MIMO System” on page 2-67.

w — Frequencies at which the magnitude and phase values of system response are obtained

column vector

Frequencies at which the magnitude and phase values of system response are obtained, specified as a column vector. You can provide the frequency vector `w` in any units; `allmargin` returns frequencies in the same units. `allmargin` interpolates between frequency points to approximate the true stability margins.

ts — Sample time

integer

Sample time, specified as an integer. `allmargin` uses `ts` to find the stability margins from frequency response data.

- For continuous-time models, set `ts = 0`.
- For discrete-time models, `ts` is a positive integer representing the sampling period. To denote a discrete-time model with unspecified sample time, set `ts = -1`.

Output Arguments**S — Gain, phase, and delay margins**

structure | structure array

Gain, phase, and delay margins, returned as a structure array.

The output `S` is a structure with the following fields:

- **GMFrequency**: All -180° (modulo 360°) crossover frequencies in `rad/TimeUnit`, where `TimeUnit` is the time units, specified in the `TimeUnit` property of `L`.
- **GainMargin**: Corresponding gain margins, defined as $1/G$, where G is the gain at the -180° crossover frequency. Gain margins are in absolute units.
- **PMFrequency**: All 0-dB crossover frequencies in `rad/TimeUnit`, where `TimeUnit` is the time units, specified in the `TimeUnit` property of `L`.
- **PhaseMargin**: Corresponding phase margins in degrees.
- **DMFrequency** and **DelayMargin**: **DelayMargin** is the maximum amount of delay that the system can tolerate before it loses stability. **DMFrequency** contains critical frequencies corresponding to the delay margins. Delay margins are specified in the time units of the system for continuous-time systems and multiples of the sample time for discrete-time systems.
- **Stable**: `1` if the nominal closed-loop system is stable, `0` if unstable, and `NaN` if stability cannot be assessed. In general, `allmargin` cannot assess the stability of an `frd` system.

When `L` is an `M`-by-`M` MIMO system, `S` is an `M`-by-1 structure array. For instance, `S(j)` gives the stability margins for the `j`-th feedback channel with all other loops closed (one-loop-at-a-time margins).

Tips

- `allmargin` assumes that the system with open-loop response `L` is a negative-feedback system. To compute the classical stability margins of the positive feedback system `feedback(L, eye(M), +1)`, use `allmargin(-L)`.

- To compute classical margins for a system modeled in Simulink, first linearize the model to obtain the open-loop response at a particular operating point. Then, use `allmargin` to compute classical stability margins for the linearized system. For more information, see “Stability Margins of a Simulink Model” (Robust Control Toolbox).

Version History

Introduced before R2006a

See Also

Linear System Analyzer | `margin` | `diskmargin`

Topics

“Stability Margins of a Simulink Model” (Robust Control Toolbox)

AnalysisPoint

Points of interest for linear analysis

Syntax

```
AP = AnalysisPoint(name)
AP = AnalysisPoint(name,N)
```

Description

`AnalysisPoint` is a Control Design Block for marking a location in a control system model as a point of interest for linear analysis and controller tuning. You can combine an `AnalysisPoint` block with numeric LTI models, tunable LTI models, and other Control Design Blocks to build tunable models of control systems. `AnalysisPoint` locations are available for analysis with commands such as `getIOTransfer` or `getLoopTransfer`. Such locations are also available for specifying design goals for control system tuning.

For example, consider the following control system.

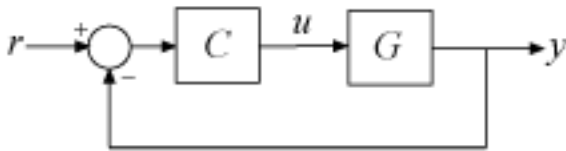

Suppose that you are interested in the effects of disturbance injected at u in this control system. Inserting an `AnalysisPoint` block at the location u associates an implied input, implied output, and the option to open the loop at that location, as in the following diagram.

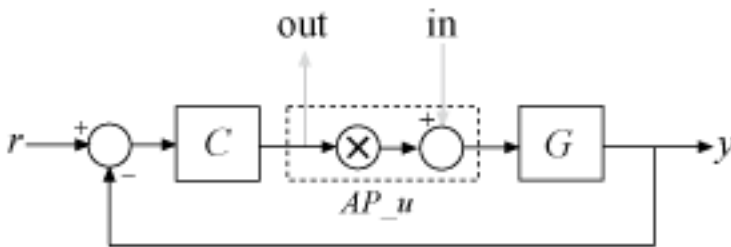

Suppose that T is a model of the control system including the `AnalysisPoint` block, `AP_u`. In this case, the command `getIOTransfer(T, 'AP_u', 'y')` returns a model of the closed-loop transfer

function from u to y . Likewise, the command `getLoopTransfer(T, 'AP_u', -1)` returns a model of the negative-feedback open-loop response, CG , measured at the location u .

`AnalysisPoint` blocks are also useful when tuning a control system using tuning commands such as `systemtune`. You can use an `AnalysisPoint` block to mark a loop-opening location for open-loop tuning requirements such as `TuningGoal.LoopShape` or `TuningGoal.Margins`. You can also use an `AnalysisPoint` block to mark the specified input or output for tuning requirements such as `TuningGoal.Gain`. For example, `Req = TuningGoal.Margins('AP_u', 5, 40)` constrains the gain and phase margins at the location u .

You can create `AnalysisPoint` blocks explicitly using the `AnalysisPoint` command and connect them with other block diagram components using model interconnection commands. For example, the following code creates a model of the system illustrated above. (See “Construction” on page 2-13 and “Examples” on page 2-0 below for more information.)

```
G = tf(1,[1 2]);
C = tunablePID('C','pi');
AP_u = AnalysisPoint('u');
T = feedback(G*AP_u*C,1);      % closed loop r->y
```

You can also create analysis points implicitly, using the `connect` command. The following syntax creates a dynamic system model with analysis points, by interconnecting multiple models `sys1, sys2, . . . , sysN`:

```
sys = connect(sys1,sys2,...,sysN,inputs,outputs,APs);
```

`APs` lists the signal locations at which to insert analysis points. The software automatically creates and inserts an `AnalysisPoint` block with channels corresponding to these locations. See `connect` for more information.

Construction

`AP = AnalysisPoint(name)` creates a single-channel analysis point. Insert `AP` anywhere in the generalized model of your control system to mark a point of interest for linear analysis or controller tuning. `name` specifies the block name.

`AP = AnalysisPoint(name,N)` creates a multi-channel analysis point with N channels. Use this block to mark a vector-valued signal as a point of interest or to bundle together several points of interest.

Input Arguments

name

Analysis point name, specified as a character vector such as `'AP'`. This input argument sets the value of the `Name` property of the `AnalysisPoint` block. (See “Properties” on page 2-14.) When you build a control system model using the block, the `Name` property is what appears in the `Blocks` list of the resulting `genss` model.

N

Number of channels for a multichannel analysis point, specified as a scalar integer.

Properties

Location

Names of channels in the `AnalysisPoint` blocks, specified as a character vector or a cell array of character vectors.

By default, the analysis-point channels are named after the `name` argument. For example, if you have a single-channel analysis point, `AP`, that has name `'AP'`, then `AP.Location = 'AP'` by default. If you have a multi-channel analysis point, then `AP.Location = {'AP(1)', 'AP(2)', ...}` by default. Set `AP.Location` to a different value if you want to customize the channel names.

Open

Loop-opening state, specified as a logical value or vector of logical values. This property tracks whether the loop is open or closed at the analysis point.

For example, consider the feedback loop of the following illustration.

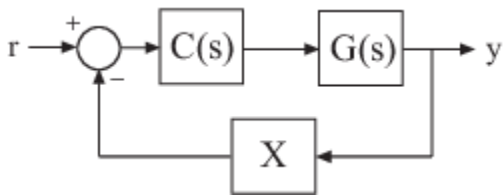

You can model this feedback loop as follows.

```
G = tf(1,[1 2]);
C = tunablePID('C','pi');
X = AnalysisPoint('X');
T = feedback(G*C,X);
T.InputName = 'r';
T.OutputName = 'y';
```

By default, the analysis point at `X` is closed. You can get the transfer function from `r` to `y` with the feedback loop open at `X` as follows.

```
Try = getIOTransfer(T,'r','y','X');
```

In the resulting generalized state-space (`genss`) model, the `AnalysisPoint` block `'X'` is marked open. In other words, `Try.Blocks.X.Open = 1`.

For a multi-channel analysis point, then `Open` is a logical vector with as many entries as the analysis point has channels.

Default: 0 for all channels

Ts

Sample time. For `AnalysisPoint` blocks, the value of this property is automatically set to the sample time of other blocks and models you connect it with.

Default: 0 (continuous time)

TimeUnit

Units for the time variable, the sample time T_s , and any time delays in the model, specified as one of the following values:

- 'nanoseconds'
- 'microseconds'
- 'milliseconds'
- 'seconds'
- 'minutes'
- 'hours'
- 'days'
- 'weeks'
- 'months'
- 'years'

Changing this property has no effect on other properties, and therefore changes the overall system behavior. Use `chgTimeUnit` to convert between time units without modifying system behavior.

Default: 'seconds'

InputName

Input channel names, specified as one of the following:

- Character vector — For single-input models, for example, 'controls'.
- Cell array of character vectors — For multi-input models.

Alternatively, use automatic vector expansion to assign input names for multi-input models. For example, if `sys` is a two-input model, enter:

```
sys.InputName = 'controls';
```

The input names automatically expand to {'controls(1)'; 'controls(2)'}

You can use the shorthand notation `u` to refer to the `InputName` property. For example, `sys.u` is equivalent to `sys.InputName`.

Input channel names have several uses, including:

- Identifying channels on model display and plots
- Extracting subsystems of MIMO systems
- Specifying connection points when interconnecting models

Default: '' for all input channels

InputUnit

Input channel units, specified as one of the following:

- Character vector — For single-input models, for example, 'seconds'.

- Cell array of character vectors — For multi-input models.

Use `InputUnit` to keep track of input signal units. `InputUnit` has no effect on system behavior.

Default: '' for all input channels

InputGroup

Input channel groups. The `InputGroup` property lets you assign the input channels of MIMO systems into groups and refer to each group by name. Specify input groups as a structure. In this structure, field names are the group names, and field values are the input channels belonging to each group. For example:

```
sys.InputGroup.controls = [1 2];  
sys.InputGroup.noise = [3 5];
```

creates input groups named `controls` and `noise` that include input channels 1, 2 and 3, 5, respectively. You can then extract the subsystem from the `controls` inputs to all outputs using:

```
sys(:, 'controls')
```

Default: Struct with no fields

OutputName

Output channel names, specified as one of the following:

- Character vector — For single-output models. For example, 'measurements'.
- Cell array of character vectors — For multi-output models.

Alternatively, use automatic vector expansion to assign output names for multi-output models. For example, if `sys` is a two-output model, enter:

```
sys.OutputName = 'measurements';
```

The output names automatically expand to {'measurements(1)'; 'measurements(2)'}

You can use the shorthand notation `y` to refer to the `OutputName` property. For example, `sys.y` is equivalent to `sys.OutputName`.

Output channel names have several uses, including:

- Identifying channels on model display and plots
- Extracting subsystems of MIMO systems
- Specifying connection points when interconnecting models

Default: '' for all output channels

OutputUnit

Output channel units, specified as one of the following:

- Character vector — For single-output models. For example, 'seconds'.
- Cell array of character vectors — For multi-output models.

Use `OutputUnit` to keep track of output signal units. `OutputUnit` has no effect on system behavior.

Default: '' for all output channels

OutputGroup

Output channel groups. The `OutputGroup` property lets you assign the output channels of MIMO systems into groups and refer to each group by name. Specify output groups as a structure. In this structure, field names are the group names, and field values are the output channels belonging to each group. For example:

```
sys.OutputGroup.temperature = [1];
sys.InputGroup.measurement = [3 5];
```

creates output groups named `temperature` and `measurement` that include output channels 1, and 3, 5, respectively. You can then extract the subsystem from all inputs to the measurement outputs using:

```
sys('measurement', :)
```

Default: Struct with no fields

Name

System name, specified as a character vector. For example, `'system_1'`.

Default: ''

Notes

Any text that you want to associate with the system, stored as a string or a cell array of character vectors. The property stores whichever data type you provide. For instance, if `sys1` and `sys2` are dynamic system models, you can set their `Notes` properties as follows:

```
sys1.Notes = "sys1 has a string.";
sys2.Notes = 'sys2 has a character vector.';
sys1.Notes
sys2.Notes
```

```
ans =
```

```
    "sys1 has a string."
```

```
ans =
```

```
    'sys2 has a character vector.'
```

Default: [0×1 string]

UserData

Any type of data you want to associate with system, specified as any MATLAB® data type.

Default: []

Examples

Feedback Loop with Analysis Point

Create a model of the following feedback loop with an analysis point in the feedback path.

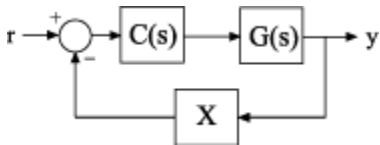

For this example, the plant model is $G = 1/(s + 2)$. C is a tunable PI controller, and X is the analysis point.

```
G = tf(1,[1 2]);
C = tunablePID('C','pi');
X = AnalysisPoint('X');
T = feedback(G*C,X);
T.InputName = 'r';
T.OutputName = 'y';
```

T is a tunable genss model. $T.Blocks$ contains the Control Design Blocks of the model, which are the controller, C , and the analysis point, X .

$T.Blocks$

```
ans = struct with fields:
    C: [1x1 tunablePID]
    X: [1x1 AnalysisPoint]
```

Examine the step response of T .

```
stepplot(T)
```

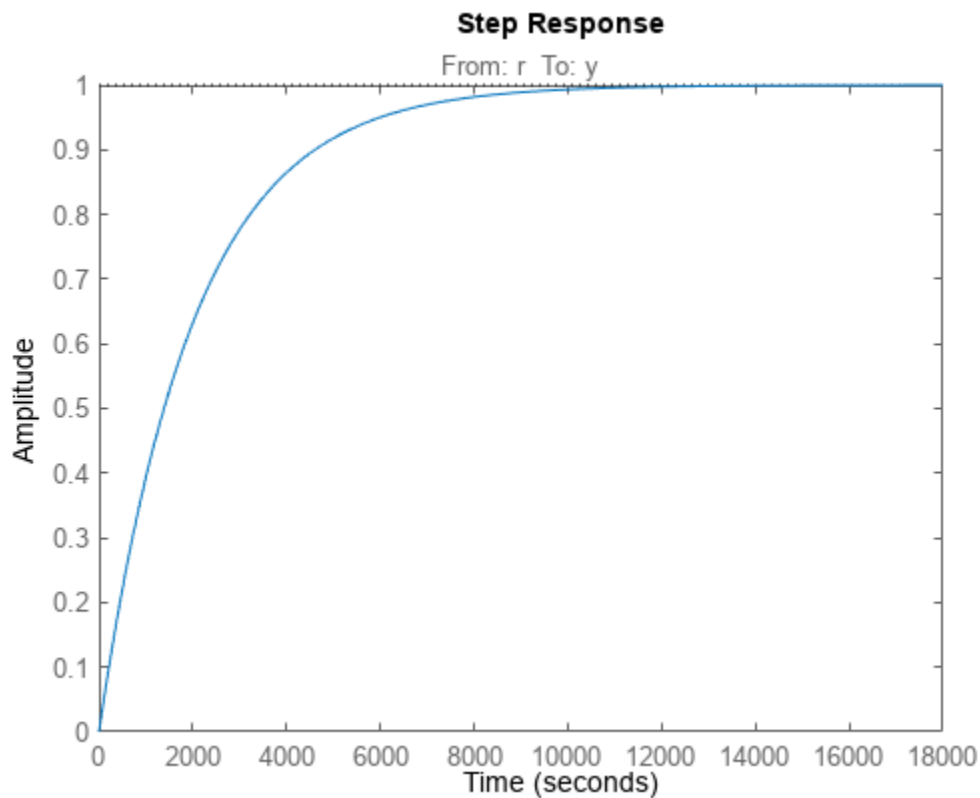

The presence of the `AnalysisPoint` block does not change the dynamics of the model.

You can use the analysis point for linear analysis of the system. For instance, extract the system response at 'y' to a disturbance injected at the analysis point.

```
Txy = getIOTransfer(T, 'X', 'y');
```

The `AnalysisPoint` block also allows you to temporarily open the feedback loop at that point. For example, compute the open-loop response from 'r' to 'y'.

```
Try_open = getIOTransfer(T, 'r', 'y', 'X');
```

Specifying the analysis point name as the last argument to `getIOTransfer` extracts the response with the loop open at that point. Examine the step response of `Try_open` to verify that it is the open-loop response.

```
stepplot(Try_open);
```

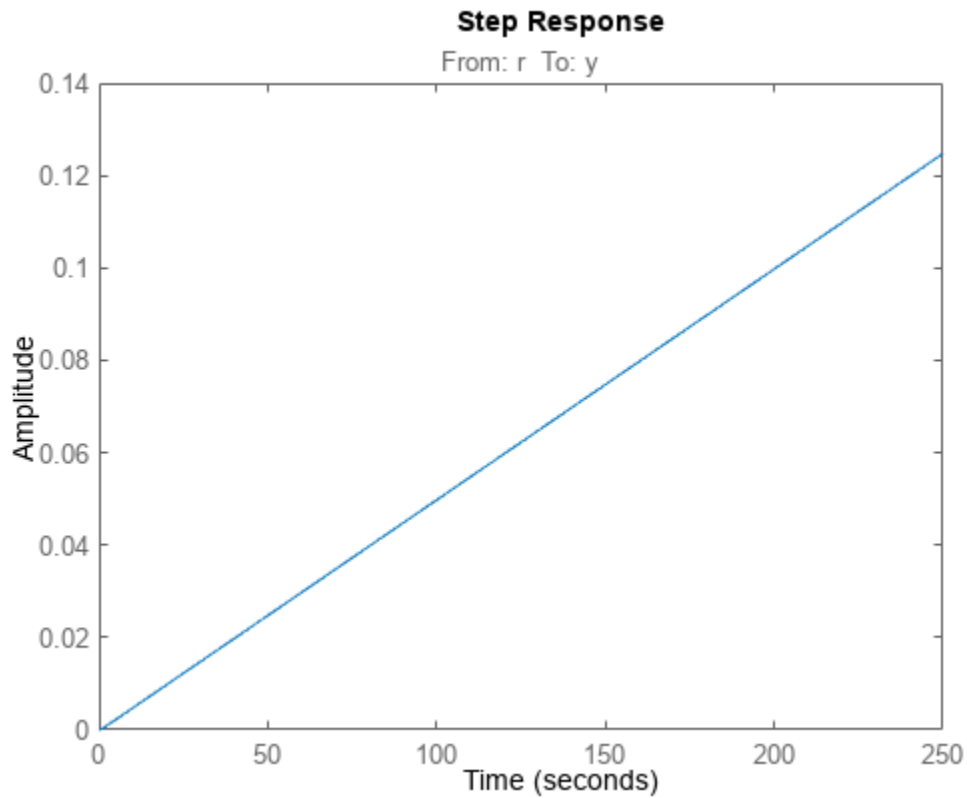

Feedback Loop With Analysis Point Inserted by connect

Create a model of the following block diagram from r to y . Insert an analysis point at an internal location, u .

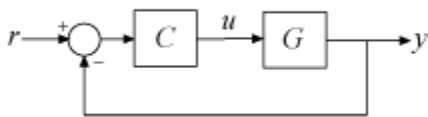

Create C and G, and name the inputs and outputs.

```
C = pid(2,1);
C.InputName = 'e';
C.OutputName = 'u';
G = zp([], [-1, -1], 1);
G.InputName = 'u';
G.OutputName = 'y';
```

Create the summing junction.

```
Sum = sumblk('e = r - y');
```

Combine C , G , and the summing junction to create the aggregate model, with an analysis point at u .

```
T = connect(G,C,Sum,'r','y','u')
```

```
T =
```

```
Generalized continuous-time state-space model with 1 outputs, 1 inputs, 3 states, and the following
AnalysisPoints_: Analysis point, 1 channels, 1 occurrences.
```

Type "ss(T)" to see the current value, "get(T)" to see all properties, and "T.Blocks" to interact

The resulting T is a `genss` model. The `connect` command creates the `AnalysisPoint` block, `AnalysisPoints_`, and inserts it into T . To see the name of the analysis point channel in `AnalysisPoints_`, use `getPoints`.

```
getPoints(T)
```

```
ans = 1x1 cell array
      {'u'}
```

The analysis point channel is named 'u'. You can use this analysis point to extract system responses. For example, the following commands extract the open-loop transfer at u and the closed-loop response at y to a disturbance injected at u .

```
L = getLoopTransfer(T,'u',-1);
Tuy = getIOTransfer(T,'u','y');
```

T is equivalent to the following block diagram, where AP_u designates the `AnalysisPoint` block `AnalysisPoints_` with channel name u .

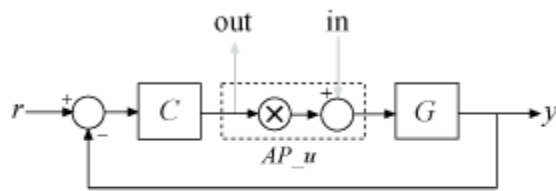

Multi-Channel Analysis Points

Create a block for marking two analysis points in a MIMO model.

In the control system of the following illustration, consider each signal a vector-valued signal of size 2. In other words, the signal r represents $\{r(1), r(2)\}$, y represents $\{y(1), y(2)\}$, and so on.

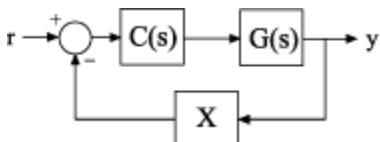

The feedback signal is therefore also a vector-valued signal of size 2. Create a block for marking the two analysis points in the feedback path.

```
AP = AnalysisPoint('X',2)
```

```
AP =
```

```
Multi-channel analysis point at locations:
```

```
  X(1)  
  X(2)
```

Type "ss(AP)" to see the current value and "get(AP)" to see all properties.

The `AnalysisPoint` block is stored as a variable in the MATLAB® workspace called `AP`. In addition, the `Name` property of the block is set to `X`. When you interconnect the block with numeric LTI models or other Control Design Blocks, this analysis-point block is identified in the `Blocks` property of the resulting `genss` model as `X`. The block name `X` is automatically expanded to generate the channel names `X(1)` and `X(2)`.

It is sometimes convenient to change the channel names to match the names of the signals they correspond to in a block diagram of your model. For example, suppose the points of interest you want to mark in your model are signals named `L` and `V`. Change the `Location` property of `AP` to make the names match those signals.

```
AP.Location = {'L';'V'}
```

```
AP =
```

```
Multi-channel analysis point at locations:
```

```
  L  
  V
```

Type "ss(AP)" to see the current value and "get(AP)" to see all properties.

Although the channel names have changed, the block name remains `X`.

```
AP.Name
```

```
ans =  
'X'
```

Therefore, the `Blocks` property of a `genss` model you build with this block still identifies the block as `X`. Use `getPoints` to find the channel names of available analysis points in a `genss` model.

Version History

Introduced in R2014b

See Also

`genss` | `getPoints` | `connect`

Topics

“Control System with Multichannel Analysis Points”

“Control Design Blocks”

“Models with Tunable Coefficients”

“Mark Signals of Interest for Control System Analysis and Design”

append

Group models by appending their inputs and outputs

Syntax

```
sys = append(sys1, sys2, ..., sysN)
```

Description

`sys = append(sys1, sys2, ..., sysN)` appends the inputs and outputs of the models `sys1, ..., sysN` to form the augmented model `sys` depicted below.

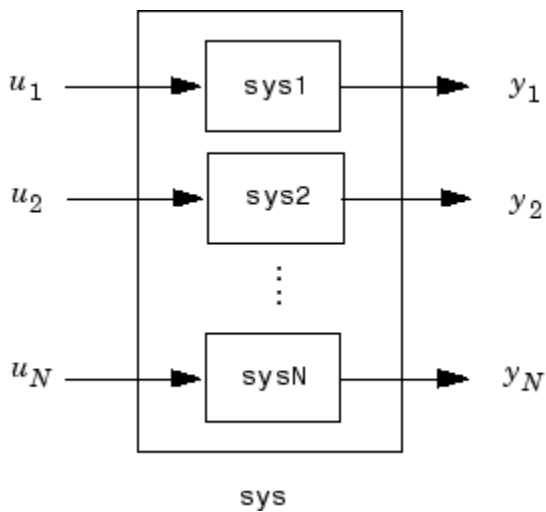

For systems with transfer functions $H_1(s), \dots, H_N(s)$, the resulting system `sys` has the block-diagonal transfer function

$$\begin{bmatrix} H_1(s) & 0 & \dots & 0 \\ 0 & H_2(s) & \dots & \vdots \\ \vdots & \vdots & \ddots & 0 \\ 0 & \dots & 0 & H_N(s) \end{bmatrix}$$

For state-space models `sys1` and `sys2` with data (A_1, B_1, C_1, D_1) and (A_2, B_2, C_2, D_2) , `append(sys1, sys2)` produces the following state-space model:

$$\begin{aligned} \begin{bmatrix} \dot{x}_1 \\ \dot{x}_2 \end{bmatrix} &= \begin{bmatrix} A_1 & 0 \\ 0 & A_2 \end{bmatrix} \begin{bmatrix} x_1 \\ x_2 \end{bmatrix} + \begin{bmatrix} B_1 & 0 \\ 0 & B_2 \end{bmatrix} \begin{bmatrix} u_1 \\ u_2 \end{bmatrix} \\ \begin{bmatrix} y_1 \\ y_2 \end{bmatrix} &= \begin{bmatrix} C_1 & 0 \\ 0 & C_2 \end{bmatrix} \begin{bmatrix} x_1 \\ x_2 \end{bmatrix} + \begin{bmatrix} D_1 & 0 \\ 0 & D_2 \end{bmatrix} \begin{bmatrix} u_1 \\ u_2 \end{bmatrix} \end{aligned}$$

Arguments

The input arguments `sys1,...`, `sysN` can be model objects of any type. Regular matrices are also accepted as a representation of static gains, but there should be at least one model in the input list. The models should be either all continuous, or all discrete with the same sample time. When appending models of different types, the resulting type is determined by the precedence rules (see “Rules That Determine Model Type” for details).

There is no limitation on the number of inputs.

Examples

Append Inputs and Outputs of Models

Create a SISO transfer function.

```
sys1 = tf(1,[1 0]);
size(sys1)
```

Transfer function with 1 outputs and 1 inputs.

Create a SISO continuous-time state-space model.

```
sys2 = ss(1,2,3,4);
size(sys2)
```

State-space model with 1 outputs, 1 inputs, and 1 states.

Append the inputs and outputs of `sys1`, a SISO static gain system, and `sys2`. The resulting model should be a 3-input, 3-output state-space model.

```
sys = append(sys1,10,sys2)
```

```
sys =
```

```
A =
      x1  x2
x1    0   0
x2    0   1
```

```
B =
      u1  u2  u3
x1    1   0   0
x2    0   0   2
```

```
C =
      x1  x2
y1    1   0
y2    0   0
y3    0   3
```

```
D =
      u1  u2  u3
y1    0   0   0
y2    0  10   0
y3    0   0   4
```

Continuous-time state-space model.

```
size(sys)
```

State-space model with 3 outputs, 3 inputs, and 2 states.

Version History

Introduced before R2006a

See Also

[connect](#) | [feedback](#) | [parallel](#) | [series](#)

augstate

Append state vector to output vector

Syntax

```
asys = augstate(sys)
```

Description

`asys = augstate(sys)` appends the state vector to the outputs of a state-space model.

Given a state-space model `sys` with equations

$$\begin{aligned}\dot{x} &= Ax + Bu \\ y &= Cx + Du\end{aligned}$$

(or their discrete-time counterpart), `augstate` appends the states `x` to the outputs `y` to form the model

$$\begin{aligned}\dot{x} &= Ax + Bu \\ \begin{bmatrix} y \\ x \end{bmatrix} &= \begin{bmatrix} C \\ I \end{bmatrix} x + \begin{bmatrix} D \\ 0 \end{bmatrix} u\end{aligned}$$

This command prepares the plant so that you can use the `feedback` command to close the loop on a full-state feedback $u = -Kx$.

Limitation

Because `augstate` is only meaningful for state-space models, it cannot be used with TF, ZPK or FRD models.

Version History

Introduced before R2006a

See Also

`feedback` | `parallel` | `series`

balreal

Gramian-based input/output balancing of state-space realizations

Syntax

```
[sysb,g] = balreal(sys)
[sysb,g,T,Ti] = balreal(sys)
[___] = balreal(sys,opts)
```

Description

`[sysb,g] = balreal(sys)` computes a balanced realization `sysb` for the stable portion of the LTI model `sys`. `balreal` handles both continuous and discrete systems. If `sys` is not a state-space model, it is first and automatically converted to state space using `ss`.

For stable systems, `sysb` is an equivalent realization for which the controllability and observability Gramians are equal and diagonal, their diagonal entries forming the vector `g` of Hankel singular values. Small entries in `g` indicate states that can be removed to simplify the model (use `modred` to reduce the model order).

If `sys` has unstable poles, its stable part is isolated, balanced, and added back to its unstable part to form `sysb`. The entries of `g` corresponding to unstable modes are set to `Inf`.

`[sysb,g,T,Ti] = balreal(sys)` also returns the vector `g` containing the diagonal of the balanced Gramian, the state similarity transformation $x_b = Tx$ used to convert `sys` to `sysb`, and the inverse transformation $Ti = T^{-1}$.

If the system is normalized properly, the diagonal `g` of the joint Gramian can be used to reduce the model order. Because `g` reflects the combined controllability and observability of individual states of the balanced model, you can delete those states with a small `g(i)` while retaining the most important input-output characteristics of the original system. Use `modred` to perform the state elimination.

`[___] = balreal(sys,opts)` computes the balanced realization using options that you specify using `balredOptions`. Options include offset and tolerance options for computing the stable-unstable decompositions. The options also allow you to limit the Gramian computation to particular time and frequency intervals. See `balredOptions` for details.

Examples

Balanced Realization of Stable System

Consider the following zero-pole-gain model, with near-canceling pole-zero pairs:

```
sys = zpk([-10 -20.01],[-5 -9.9 -20.1],1)
```

```
sys =
```

```
      (s+10) (s+20.01)
```

```
-----
```

```
(s+5) (s+9.9) (s+20.1)
```

Continuous-time zero/pole/gain model.

A state-space realization with balanced gramians is obtained by

```
[sysb,g] = balreal(sys);
```

The diagonal entries of the joint gramian are

```
g'
```

```
ans = 1×3
```

```
0.1006    0.0001    0.0000
```

This indicates that the last two states of `sysb` are weakly coupled to the input and output. You can then delete these states by

```
sysr = modred(sysb,[2 3], 'del');
```

This yields the following first-order approximation of the original system.

```
zpk(sysr)
```

```
ans =
```

```
1.0001
-----
(s+4.97)
```

Continuous-time zero/pole/gain model.

Compare the Bode responses of the original and reduced-order models.

```
bodeplot(sys,sysr,'r--')
```

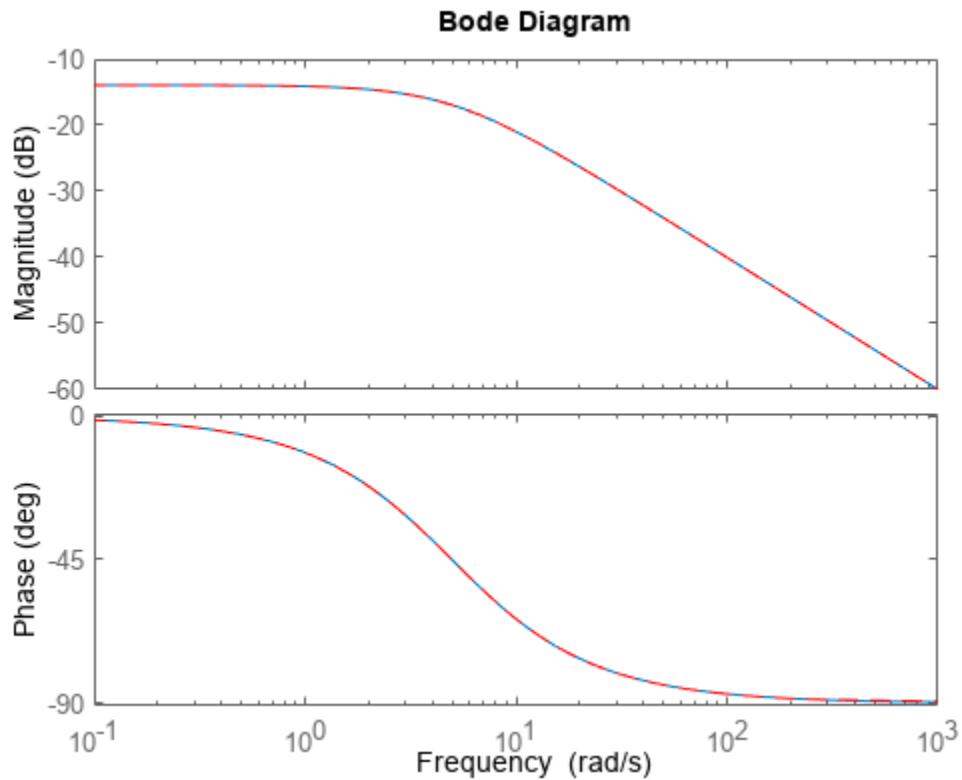

The plots show that removing the second and third states does not have much effect on system dynamics.

Balanced Realization of Unstable System

Create an unstable system.

```
sys = tf(1,[1 0 -1])
```

```
sys =
```

$$\frac{1}{s^2 - 1}$$

Continuous-time transfer function.

Apply `balreal` to create a balanced-gramian realization.

```
[sysbal,g] = balreal(sys)
```

```
sysbal =
```

$$A = \begin{matrix} & x1 & x2 \\ x1 & & \\ x2 & & \end{matrix}$$

```

x1  1  0
x2  0 -1

B =
      u1
x1 -0.7071
x2 -0.7071

C =
      x1  x2
y1 -0.7071  0.7071

D =
      u1
y1  0

```

Continuous-time state-space model.

$g = 2 \times 1$

```

      Inf
0.2500

```

The unstable pole shows up as Inf in the vector g.

Algorithms

Consider the model

$$\begin{aligned}\dot{x} &= Ax + Bu \\ y &= Cx + Du\end{aligned}$$

with controllability and observability Gramians W_c and W_o . The state coordinate transformation $\bar{x} = Tx$ produces the equivalent model

$$\begin{aligned}\dot{\bar{x}} &= TAT^{-1}\bar{x} + TBu \\ y &= CT^{-1}\bar{x} + Du\end{aligned}$$

and transforms the Gramians to

$$\bar{W}_c = TW_cT^T, \quad \bar{W}_o = T^{-T}W_oT^{-1}$$

The function `balreal` computes a particular similarity transformation T such that

$$\bar{W}_c = \bar{W}_o = \text{diag}(g)$$

See [1], [2] for details on the algorithm.

If you use the `TimeIntervals` or `FreqIntervals` options of `balredOptions`, then `balreal` bases the balanced realization on time-limited or frequency-limited controllability and observability Gramians. For information about calculating time-limited and frequency-limited Gramians, see `gram` and [4].

Version History

Introduced before R2006a

References

- [1] Laub, A.J., M.T. Heath, C.C. Paige, and R.C. Ward, "Computation of System Balancing Transformations and Other Applications of Simultaneous Diagonalization Algorithms," *IEEE® Trans. Automatic Control*, AC-32 (1987), pp. 115-122.
- [2] Moore, B., "Principal Component Analysis in Linear Systems: Controllability, Observability, and Model Reduction," *IEEE Transactions on Automatic Control*, AC-26 (1981), pp. 17-31.
- [3] Laub, A.J., "Computation of Balancing Transformations," *Proc. ACC*, San Francisco, Vol.1, paper FA8-E, 1980.
- [4] Gawronski, W. and J.N. Juang. "Model Reduction in Limited Time and Frequency Intervals." *International Journal of Systems Science*. Vol. 21, Number 2, 1990, pp. 349-376.

See Also

`balred` | `balredOptions` | `gram` | `modred`

balred

Model order reduction

Syntax

```
[rsys,info] = balred(sys,order)
[~,info] = balred(sys)
[___] = balred(___,opts)
```

```
balred(sys)
```

Description

`[rsys,info] = balred(sys,order)` computes a reduced-order approximation `rsys` of the LTI model `sys`. The desired order (number of states) is specified by `order`. You can try multiple orders at once by setting `order` to a vector of integers, in which case `rsys` is an array of reduced models. `balred` also returns a structure `info` with additional information like the Hankel singular values (HSV), error bound, regularization level and the Cholesky factors of the gramians.

`[~,info] = balred(sys)` returns the structure `info` without computing the reduced-order model. You can use this information to select the reduced order `order` based on your desired fidelity.

Note When performance is a concern, avoid computing the Hankel singular values twice by using the information obtained from the above syntax to select the desired model order and then use `rsys = balred(sys,order,info)` to compute the reduced-order model.

`[___] = balred(___,opts)` computes the reduced model using the options set `opts` that you specify using `balredOptions`. You can specify additional options for eliminating states, using absolute vs. relative error control, emphasizing certain time or frequency bands, and separating the stable and unstable modes. See `balredOptions` to create and configure the option set `opts`.

`balred(sys)` displays the Hankel singular values and approximation error on a plot. Use `hsvplot` to customize this plot.

Examples

Reduced-Order Model using Hankel Singular Values

For this example, use the Hankel singular value plot to select suitable order and compute the reduced-order model.

For this instance, generate a random discrete-time state-space model with 40 states.

```
rng(0)
sys = drss(40);
```

Plot the Hankel singular values using `balred`.

```
balred(sys)
```

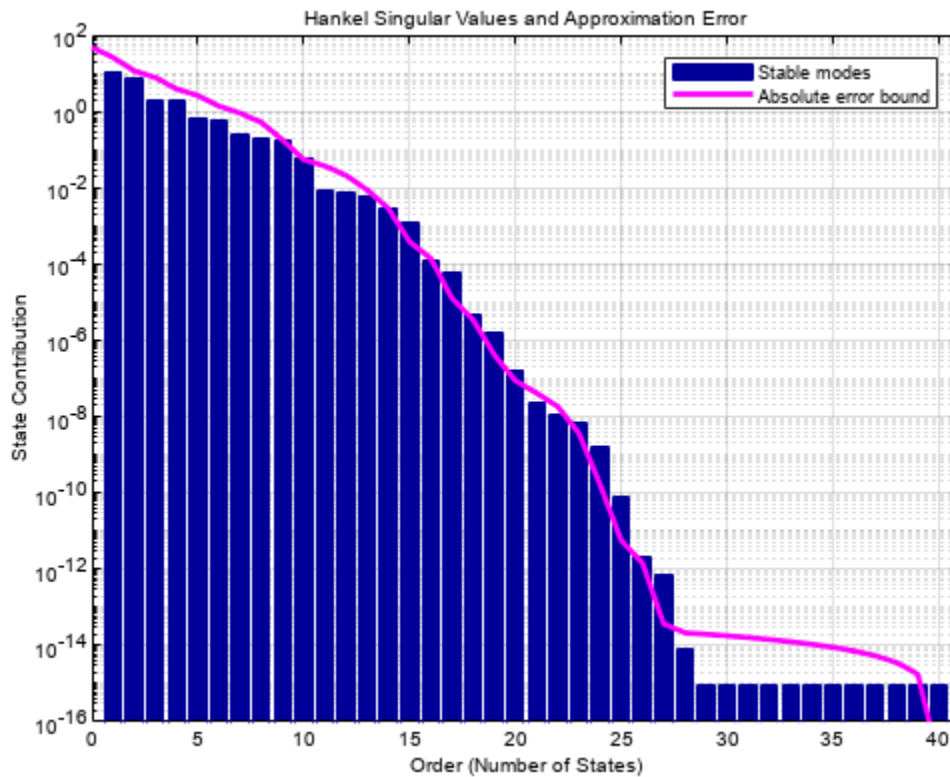

For this example, select order of 16 since it is the first order with an absolute error less than $1e-4$. In general, you select the order based on the desired absolute or relative fidelity. Then, compute the reduced-order model.

```
rsys = balred(sys,16);
```

Verify the absolute error by plotting the singular value response using `sigma`.

```
sigma(sys,sys-rsys)
```

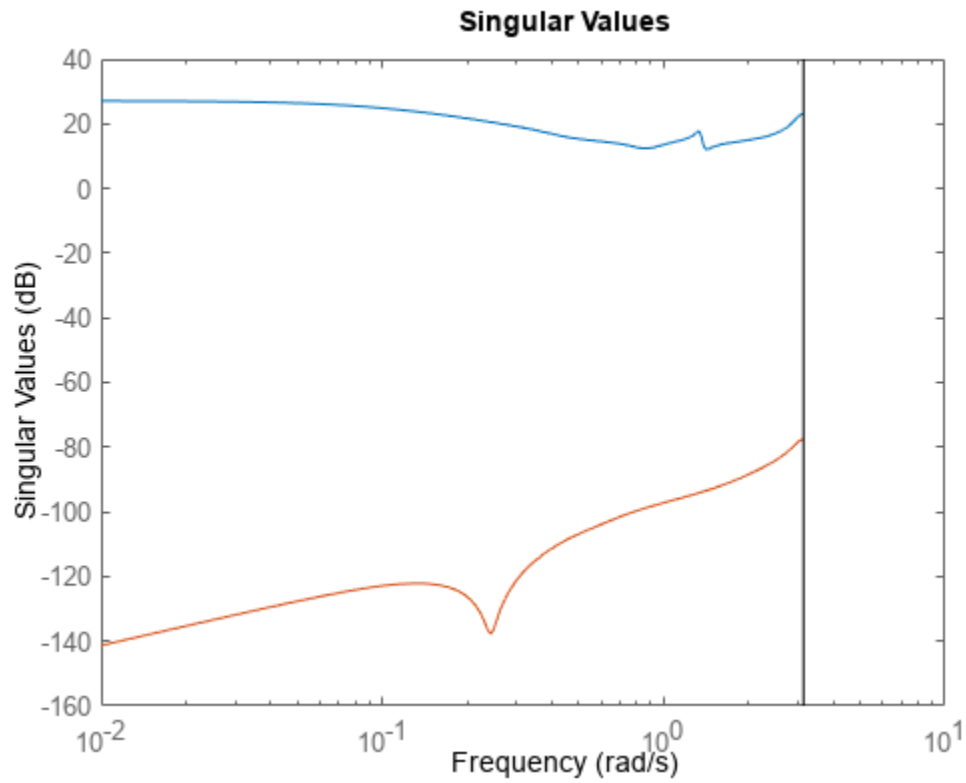

Observe from the plot that the error, represented by the red curve, is below -80 dB ($1e-4$).

Array of Reduced-Order Models

For this example, consider a random continuous-time state-space model with 65 states.

```
rng(0)
sys = rss(65);
size(sys)
```

State-space model with 1 outputs, 1 inputs, and 65 states.

Visualize the Hankel singular values on a plot.

```
balred(sys)
```

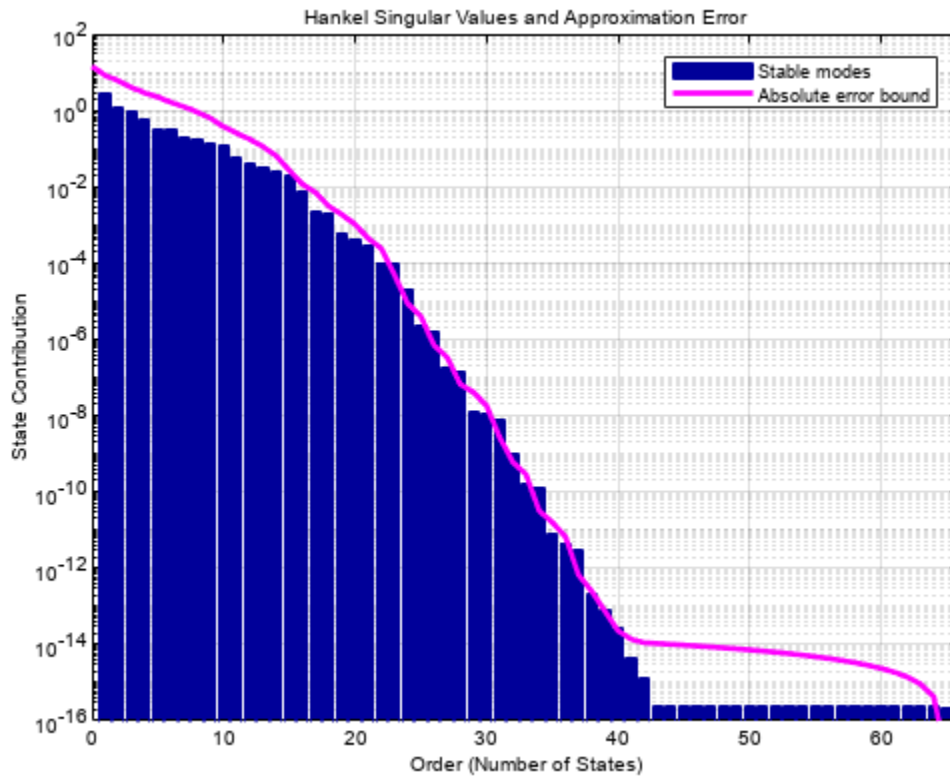

For this instance, compute reduced-order models with 25, 30 and 35 states.

```
order = [25,30,35];
rsys = balred(sys,order);
size(rsys)
```

3x1 array of state-space models.
Each model has 1 outputs, 1 inputs, and between 25 and 35 states.

Reduced-Order Approximation with Offset Option

Compute a reduced-order approximation of the system given by:

$$G(s) = \frac{(s + 0.5)(s + 1.1)(s + 2.9)}{(s + 10^{-6})(s + 1)(s + 2)(s + 3)}.$$

Create the model.

```
sys = zpk([-0.5 -1.1 -2.9],[-1e-6 -2 -1 -3],1);
```

Exclude the pole at $s = 10^{-6}$ from the stable term of the stable/unstable decomposition. To do so, set the `Offset` option of `balredOptions` to a value larger than the pole you want to exclude.

```
opts = balredOptions('Offset',0.001,'StateProjection','Truncate');
```

Visualize the Hankel singular values (HSV) and the approximation error.

```
balred(sys,opts)
```

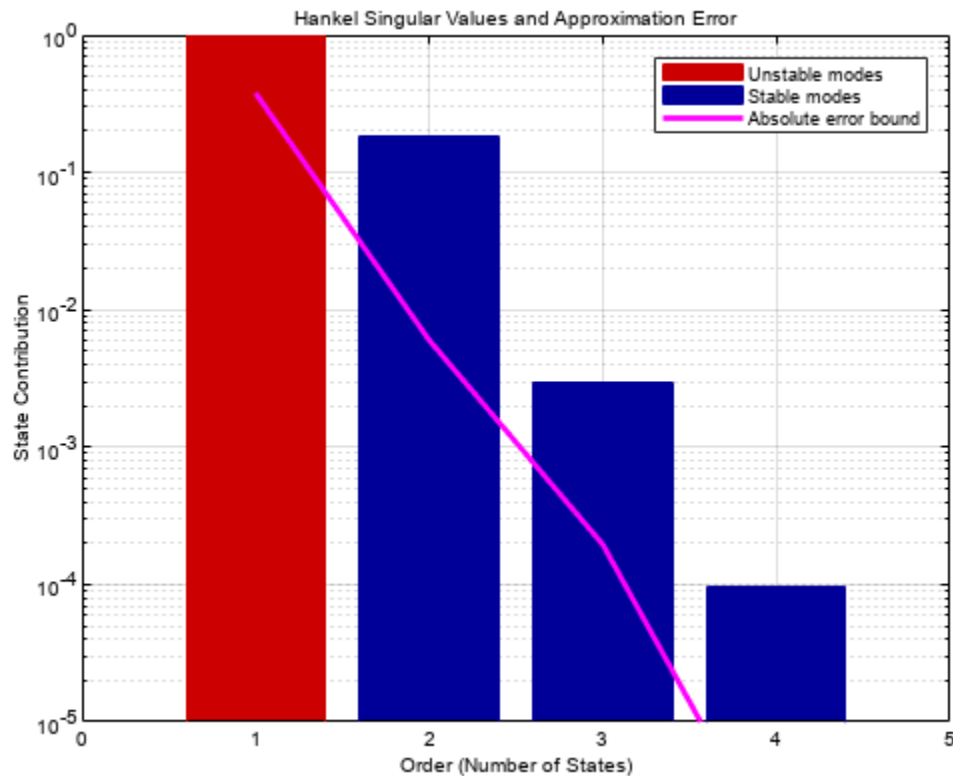

Observe that the first HSV is red which indicates that it is associated with an unstable mode.

Now, compute a second-order approximation with the specified options.

```
[rsys,info] = balred(sys,2,opts);
rsys
```

```
rsys =
```

```
  0.99113 (s+0.5235)
-----
 (s+1e-06) (s+1.952)
```

Continuous-time zero/pole/gain model.

Notice that the pole at $-1e-6$ appears unchanged in the reduced model `rsys`.

Compare the responses of the original and reduced-order models.

```
bodeplot(sys,rsys,'r--')
```

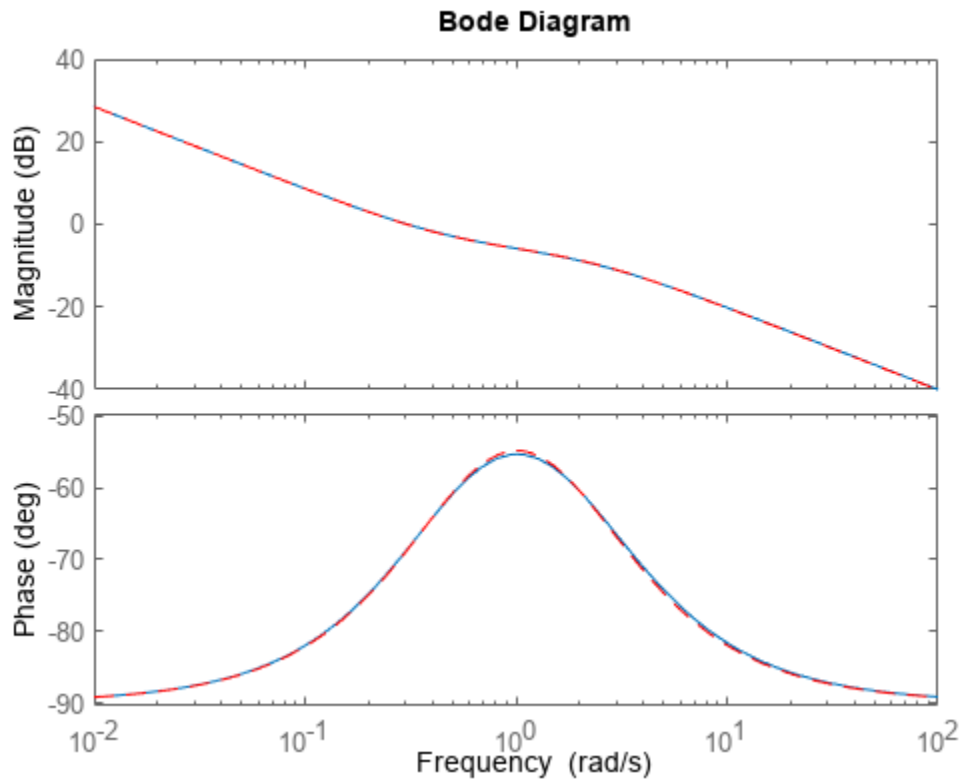

Observe that the bode response of the original model and the reduced-order model nearly match.

Model Reduction in a Particular Frequency Band

Reduce a high-order model with a focus on the dynamics in a particular frequency range.

Load a model and examine its frequency response.

```
load('highOrderModel.mat', 'G')  
bodeplot(G)
```

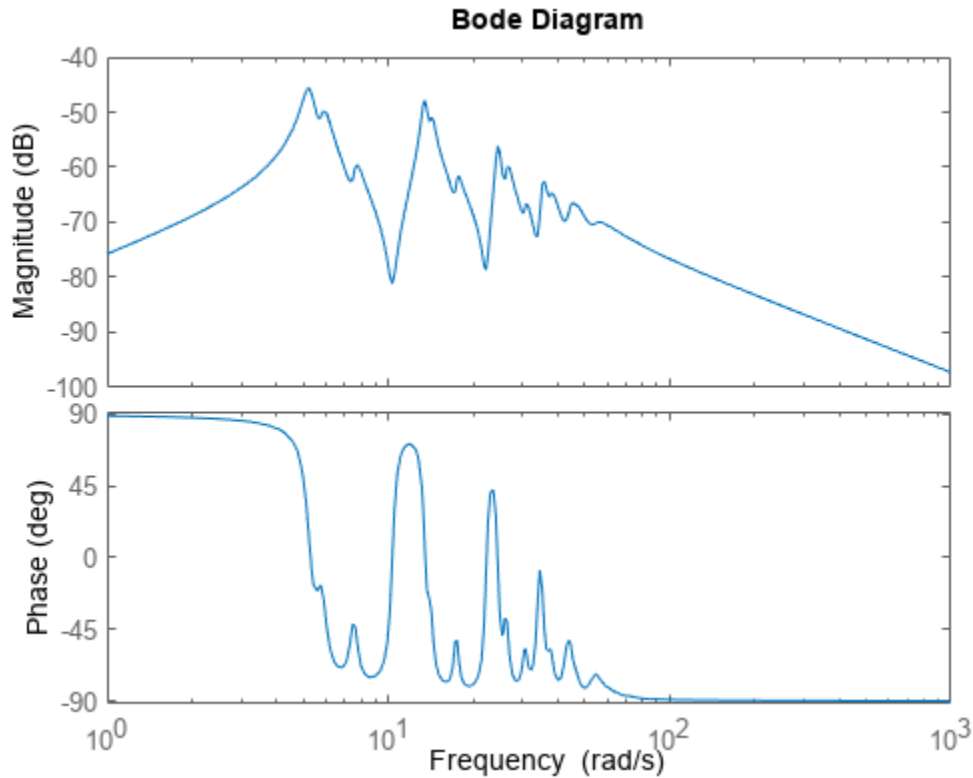



G is a 48th-order model with several large peak regions around 5.2 rad/s, 13.5 rad/s, and 24.5 rad/s, and smaller peaks scattered across many frequencies. Suppose that for your application you are only interested in the dynamics near the second large peak, between 10 rad/s and 22 rad/s. Focus the model reduction on the region of interest to obtain a good match with a low-order approximation. Use `balredOptions` to specify the frequency interval for `balred`.

```
bopt = balredOptions('StateProjection','Truncate','FreqIntervals',[10,22]);
GLim10 = balred(G,10,bopt);
GLim18 = balred(G,18,bopt);
```

Examine the frequency responses of the reduced-order models. Also, examine the difference between those responses and the original response (the absolute error).

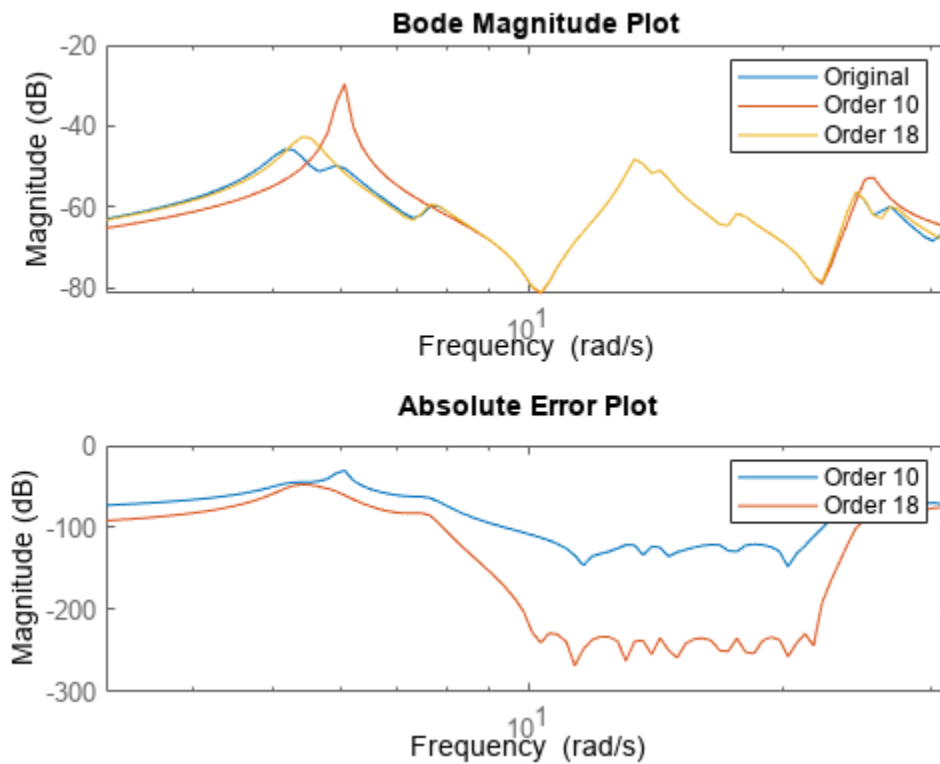
```
subplot(2,1,1);
bodemag(G,GLim10,GLim18,logspace(0.5,1.5,100));
title('Bode Magnitude Plot');
legend('Original','Order 10','Order 18');
subplot(2,1,2);
bodemag(G-GLim10,G-GLim18,logspace(0.5,1.5,100));
title('Absolute Error Plot');
legend('Order 10','Order 18');
```



With the frequency-limited energy computation, even the 10th-order approximation is quite good in the region of interest.

Model-Order Reduction with Relative Error Approximation

For this example, consider the SISO state-space model `cdrom` with 120 states. You can use absolute or relative error control when approximating models with `balred`. This example compares the two approaches when applied to a 120-state model of a portable CD player device `cdrom` [1,2] on page 2-41.

Load the CD player model `cdrom`.

```
load cdromData.mat cdrom
size(cdrom)
```

State-space model with 1 outputs, 1 inputs, and 120 states.

To compare results with absolute vs. relative error control, create one option set for each approach.

```
opt_abs = balredOptions('ErrorBound','absolute','StateProjection','truncate');
opt_rel = balredOptions('ErrorBound','relative','StateProjection','truncate');
```

Compute reduced-order models of order 15 with both approaches.

```
rsys_abs = balred(cdrom,15,opt_abs);
rsys_rel = balred(cdrom,15,opt_rel);
size(rsys_abs)
```

State-space model with 1 outputs, 1 inputs, and 15 states.

```
size(rsys_rel)
```

State-space model with 1 outputs, 1 inputs, and 15 states.

Plot the Bode response of the original model along with the absolute-error and relative-error reduced models.

```
bo = bodeoptions;
bo.PhaseMatching = 'on';
bodeplot(cdrom,'b.',rsys_abs,'r',rsys_rel,'g',bo)
legend('Original (120 states)', 'Absolute Error (15 states)', 'Relative Error (15 states)')
```

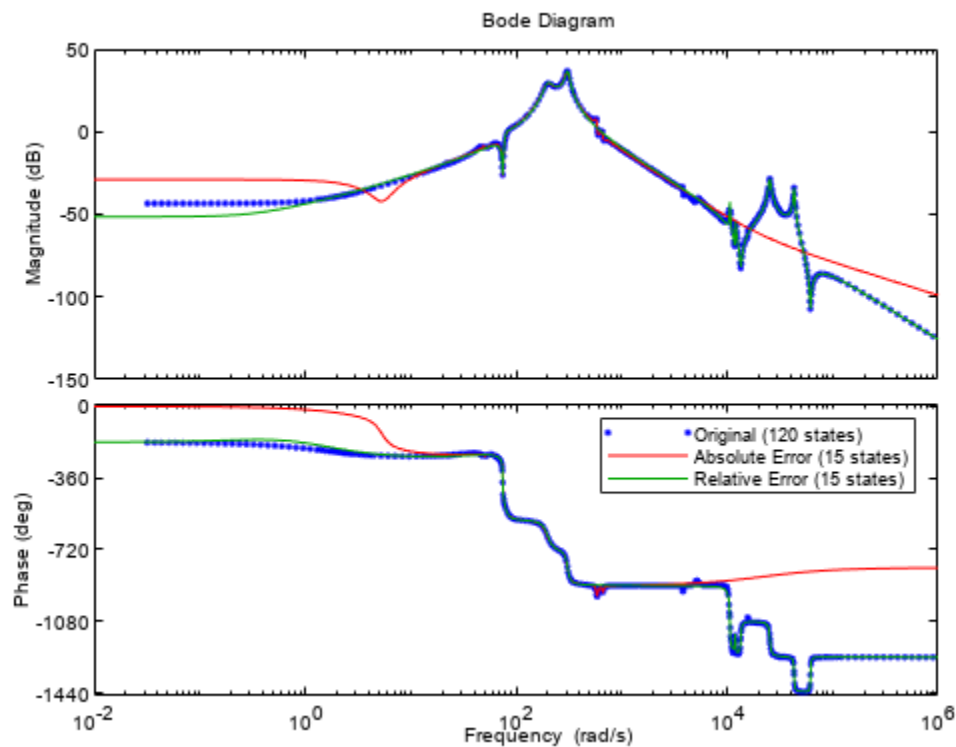

Observe that the Bode response of:

- The relative-error reduced model `rsys_rel` nearly matches the response of the original model `sys` across the complete frequency range.
- The absolute-error reduced model `rsys_abs` matches the response of the original model `sys` only in areas with the most gain.

References

- 1 [Benchmark Examples for Model Reduction](#), Subroutine Library in Systems and Control Theory (SLICOT). The CDROM data set is reproduced with permission, see BSD3-license for details.
- 2 A.Varga, "On stochastic balancing related model reduction", *Proceedings of the 39th IEEE Conference on Decision and Control (Cat. No.00CH37187)*, Sydney, NSW, 2000, pp. 2385-2390 vol.3, doi: 10.1109/CDC.2000.914156.

Input Arguments

sys — Dynamic system

dynamic system model

Dynamic system, specified as a SISO or MIMO dynamic system model. Dynamic systems that you can use can be continuous-time or discrete-time numeric LTI models, such as `tf`, `zpk`, or `ss` models.

When `sys` has unstable poles, `balred` decomposes `sys` to its stable and unstable parts and only the stable part is approximated. Use `balredOptions` to specify additional options for the stable/unstable decomposition.

`balred` does not support frequency response data models, uncertain and generalized state-space models, PID models or sparse model objects.

order — Desired number of states

integer | vector of integers

Desired number of states, specified as an integer or a vector of integers. You can try multiple orders at once by setting `order` to a vector of integers, in which case `rys` is returned as an array of reduced models.

You can also use the Hankel singular values and error bound information to select the reduced-model order based on the desired model fidelity.

opts — Additional options for model reduction

options set

Additional options for model reduction, specified as an options set. You can specify additional options for eliminating states, using absolute vs. relative error control, emphasizing certain time or frequency bands, and separating the stable and unstable modes.

See `balredOptions` to create and configure the option set `opts`.

Output Arguments

rsys — Reduced-order model

dynamic system model | array of dynamic system models

Reduced-order model, returned as a dynamic system model or an array of dynamic system models.

info — Additional information about the LTI model

structure

Additional information about the LTI model, returned as a structure with the following fields:

- `HSV` — Hankel singular values (state contributions to the input/output behavior). In state coordinates that equalize the input-to-state and state-to-output energy transfers, the Hankel

singular values measure the contribution of each state to the input/output behavior. Hankel singular values are to model order what singular values are to matrix rank. In particular, small Hankel singular values signal states that can be discarded to simplify the model.

- **ErrorBound** — Bound on absolute or relative approximation error. `info.ErrorBound(J+1)` bounds the error for order J .
- **Regularization** — Regularization level ϵ (for relative error only). Here, `sys` is replaced by `[sys, ρ *I]` or `[sys; ρ *I]` that ensures a well-defined relative error at all frequencies.
- **Rr, Ro** — Cholesky factors of gramians.

Algorithms

- 1 `balred` first decomposes G into its stable and unstable parts:

$$G = G_s + G_u$$

- 2 When you specify **ErrorBound** as **absolute**, `balred` uses the balanced truncation method of [1] to reduce G_s . This computes the Hankel singular values (HSV) σ_j based on the controllability and observability gramians. For order r , the absolute error $\|G_s - G_r\|_\infty$ is bounded by $2 \sum_{j=r+1}^n \sigma_j$. Here, n is the number of states in G_s .

- 3 When you specify **ErrorBound** as **relative**, `balred` uses the balanced stochastic truncation method of [2] to reduce G_s . For square G_s , this computes the HSV σ_j of the phase matrix $F = (W')^{-1}G$ where $W(s)$ is a stable, minimum-phase spectral factor of GG' :

$$W'(s)W(s) = G(s)G'(s)$$

For order r , the relative error $\|G_s^{-1}(G_s - G_r)\|_\infty$ is bounded by:

$$\prod_{j=r+1}^n \left(\frac{1 + \sigma_j}{1 - \sigma_j} \right) - 1 \approx 2 \sum_{j=r+1}^n \sigma_j$$

$$\text{when, } 2 \sum_{j=r+1}^n \sigma_j \ll 1.$$

Alternative Functionality

App

Model Reducer

Live Editor Task

Reduce Model Order

Version History

Introduced before R2006a

MatchDC option honored when specified frequency or time intervals exclude DC

Behavior changed in R2017b

When you use `balred` for model reduction, you can use `balredOptions` to restrict the computation to specified frequency or time intervals. If the `StateProjection` option of `balredOptions` is set to `'MatchDC'` (the default value), then `balred` attempts to match the DC gain of the original and reduced models, even if the specified intervals exclude DC (frequency = 0 or time = Inf).

Prior to R2017b, if you specified time or frequency intervals that excluded DC, `balred` did not attempt to match the DC gain of the original and reduced models, even if `StateProjection = 'MatchDC'`.

References

- [1] Varga, A., "Balancing-Free Square-Root Algorithm for Computing Singular Perturbation Approximations," *Proc. of 30th IEEE CDC*, Brighton, UK (1991), pp. 1062-1065.
- [2] Green, M., "A Relative Error Bound for Balanced Stochastic Truncation", *IEEE Transactions on Automatic Control*, Vol. 33, No. 10, 1988

See Also

Functions

`balredOptions`

Apps

Model Reducer

Live Editor Tasks

Reduce Model Order

Topics

"Model Reduction Basics"

"Balanced Truncation Model Reduction"

balredOptions

Create option set for model order reduction

Syntax

```
opts = balredOptions
opts = balredOptions('OptionName', OptionValue)
```

Description

`opts = balredOptions` returns the default option set for the `balred` command.

`opts = balredOptions('OptionName', OptionValue)` accepts one or more comma-separated name/value pairs. Specify *OptionName* inside single quotes.

Input Arguments

Name-Value Pair Arguments

StateProjection

State elimination method. Specifies how to eliminate the weakly coupled states (states with smallest Hankel singular values). Specified as one of the following values:

'MatchDC'	Discards the specified states and alters the remaining states to preserve the DC gain.
'Truncate'	Discards the specified states without altering the remaining states. This method tends to product a better approximation in the frequency domain, but the DC gains are not guaranteed to match.

Default: 'MatchDC'

ErrorBound

Error bound type, specified as either 'absolute' or 'relative'. Set 'Errorbound' to

- 'absolute' to control the absolute error $\|G - G_r\|_\infty$.
- 'relative' to control the relative error $\|G^{-1}(G - G_r)\|_\infty$.

Relative error gives a better match across frequency while absolute error emphasizes areas with most gain. For more information, see `getPeakGain`.

Default: 'absolute'

Regularization

Regularization level value that ensures a well-defined relative error at all frequencies. When you set ErrorBound to 'relative', `balred` reduces the model `[sys, rho*I]` instead of `sys`. Set this option to

'auto' to let `balred` pick a suitable regularization level ρ value. Specify a value $\rho \geq 0$ to override this default.

Default: 'auto'

FreqIntervals

Frequency intervals for computing frequency-limited Hankel singular values, specified as a matrix with two columns. Each row specifies a frequency interval `[fmin fmax]`, where `fmin` and `fmax` are nonnegative frequencies, expressed in the frequency unit of the model. When identifying low-energy states to truncate, the software computes state contributions to system behavior in these frequency ranges only. For example:

- To restrict the computation to the range between 3 rad/s and 15 rad/s, assuming the frequency unit of the model is rad/s, set `FreqIntervals` to `[3 15]`.
- To restrict the computation to two frequency intervals, 3-15 rad/s and 40-60 rad/s, use `[3 15; 40 60]`.
- To specify all frequencies below a cutoff frequency `fcut`, use `[0 fcut]`.
- To specify all frequencies above the cutoff, use `[fcut Inf]` in continuous time, or `[fcut pi/Ts]` in discrete time, where `Ts` is the sample time of the model.

The default value, `[]`, imposes no frequency limitation and is equivalent to `[0 Inf]` in continuous time or `[0 pi/Ts]` in discrete time. However, if you specify a `TimeIntervals` value other than `[]`, then this limit overrides `FreqIntervals = []`. If you specify both a `TimeIntervals` value and a `FreqIntervals` value, then the computation uses the union of these intervals.

If `StateProjection = 'MatchDC'` (the default value), then `balred` attempts to match the DC gain of the original and reduced models, even if the specified frequency intervals exclude 0. This behavior might reduce the quality of the match in the specified intervals. To improve the match within frequency intervals that exclude 0, set `StateProjection = 'Truncate'`.

If both the frequency and time intervals do include DC, you can still set `StateElimMethod = 'Truncate'` to improve the match at other frequencies and times.

Default: `[]`

TimeIntervals

Time intervals for computing time-limited Hankel singular values, specified as a matrix with two columns. Each row specifies a time interval `[tmin tmax]`, where `tmin` and `tmax` are nonnegative times, expressed in the time unit of the model. When identifying low-energy states to truncate, the software computes state contributions to the system's impulse response in these time intervals only. For example:

- To restrict the computation to the range between 3 s and 15 s, assuming the time unit of the model is seconds, set `TimeIntervals` to `[3 15]`.
- To restrict the computation to two time intervals, 3-15 s and 40-60 s, use `[3 15; 40 60]`.
- To specify all times from zero up to a cutoff time `tcut`, use `[0 tcut]`. To specify all times after the cutoff, use `[tcut Inf]`.

The default value, `[]`, imposes no time limitation and is equivalent to `[0 Inf]`. However, if you specify a `FreqIntervals` value other than `[]`, then this limit overrides `Timeintervals = []`. If

you specify both a `TimeIntervals` value and a `FreqIntervals` value, then the computation uses the union of these intervals.

If `StateProjection = 'MatchDC'` (the default value), then `balred` attempts to match the DC gain of the original and reduced models, even if the specified time intervals exclude `Inf`. This behavior might reduce the quality of the match in the specified intervals. To improve the match within time intervals that exclude `Inf`, set `StateProjection = 'Truncate'`.

If both the frequency and time intervals do include DC, you can still set `StateProjection = 'Truncate'` to improve the match at other frequencies and times.

Default: []

SepTol

Maximum loss of accuracy value in stable and unstable decomposition. For models with unstable poles, `balred` first extracts the stable dynamics using `stabsep`. Use `'SepTol'` to control the decomposition accuracy. Increasing `'SepTol'` helps separate nearby stable and unstable modes at the expense of accuracy. For more information, see `stabsepOptions`.

Default: 10

Offset

Offset for the stable/unstable boundary. Positive scalar value. In the stable/unstable decomposition, the stable term includes only poles satisfying

- $\text{Re}(s) < -\text{Offset} * \max(1, |\text{Im}(s)|)$ (Continuous time)
- $|z| < 1 - \text{Offset}$ (Discrete time)

Increase the value of `Offset` to treat poles close to the stability boundary as unstable.

Default: 1e-8

For additional information on the options and how to use them, see the `balred` reference page.

Examples

Reduced-Order Approximation with Offset Option

Compute a reduced-order approximation of the system given by:

$$G(s) = \frac{(s + 0.5)(s + 1.1)(s + 2.9)}{(s + 10^{-6})(s + 1)(s + 2)(s + 3)}$$

Create the model.

```
sys = zpk([-0.5 -1.1 -2.9], [-1e-6 -2 -1 -3], 1);
```

Exclude the pole at $s = 10^{-6}$ from the stable term of the stable/unstable decomposition. To do so, set the `Offset` option of `balredOptions` to a value larger than the pole you want to exclude.

```
opts = balredOptions('Offset', 0.001, 'StateProjection', 'Truncate');
```

Visualize the Hankel singular values (HSV) and the approximation error.

```
balred(sys,opts)
```

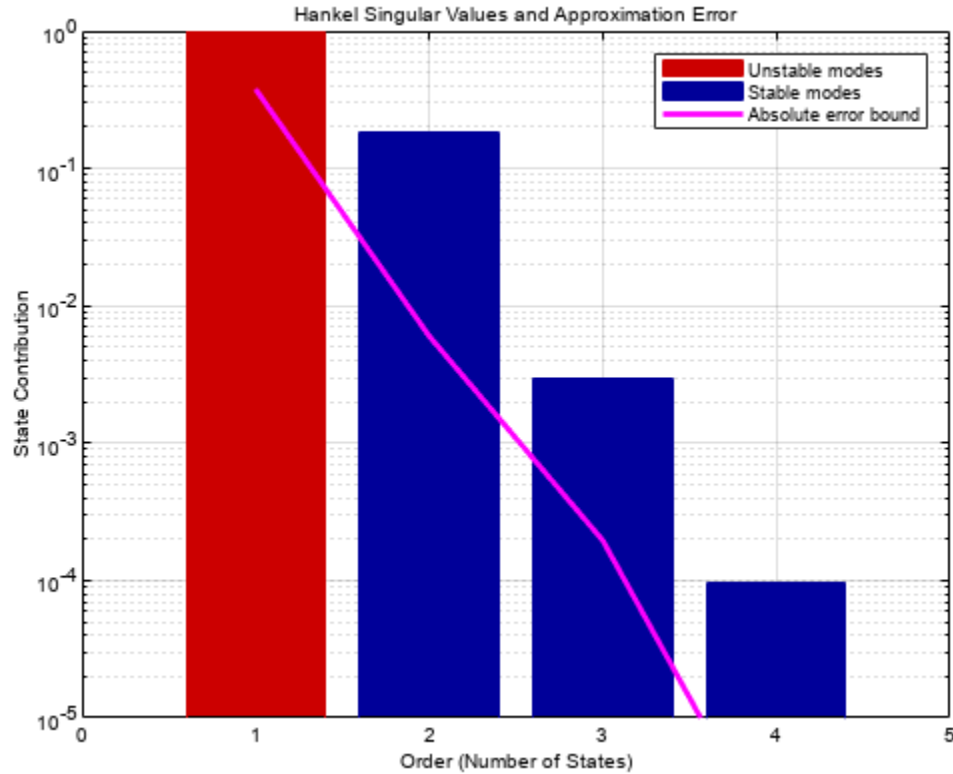

Observe that the first HSV is red which indicates that it is associated with an unstable mode.

Now, compute a second-order approximation with the specified options.

```
[rsys,info] = balred(sys,2,opts);
rsys
```

```
rsys =
```

```
0.99113 (s+0.5235)
-----
(s+1e-06) (s+1.952)
```

```
Continuous-time zero/pole/gain model.
```

Notice that the pole at $-1e-6$ appears unchanged in the reduced model `rsys`.

Compare the responses of the original and reduced-order models.

```
bodeplot(sys,rsys,'r--')
```

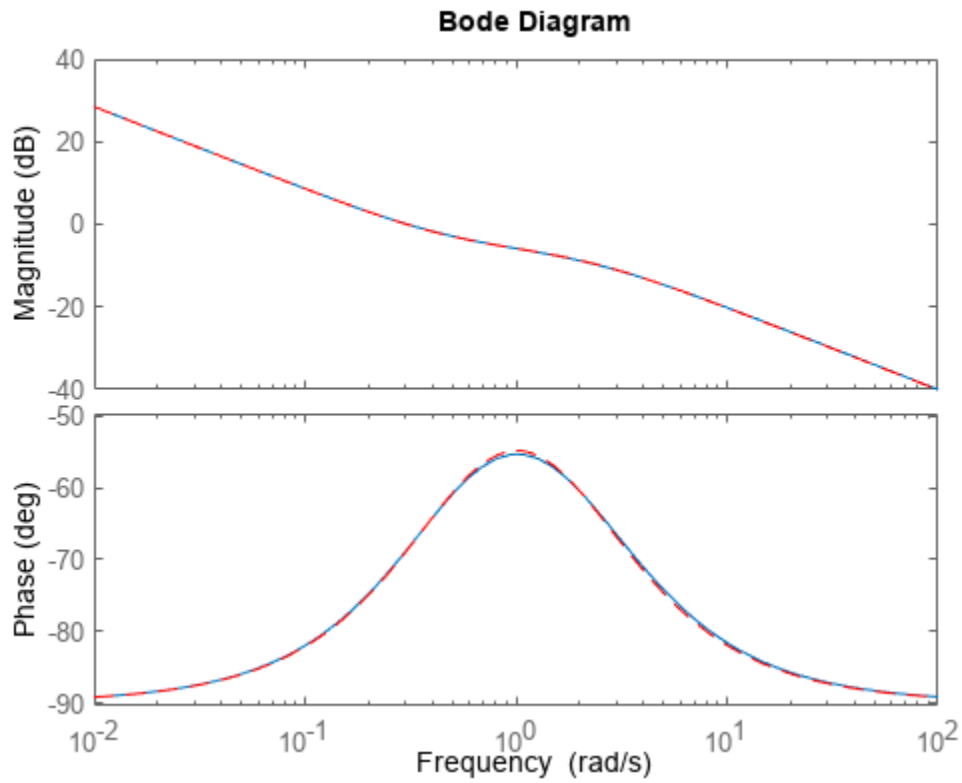

Observe that the bode response of the original model and the reduced-order model nearly match.

Model Reduction in a Particular Frequency Band

Reduce a high-order model with a focus on the dynamics in a particular frequency range.

Load a model and examine its frequency response.

```
load('highOrderModel.mat', 'G')  
bodeplot(G)
```

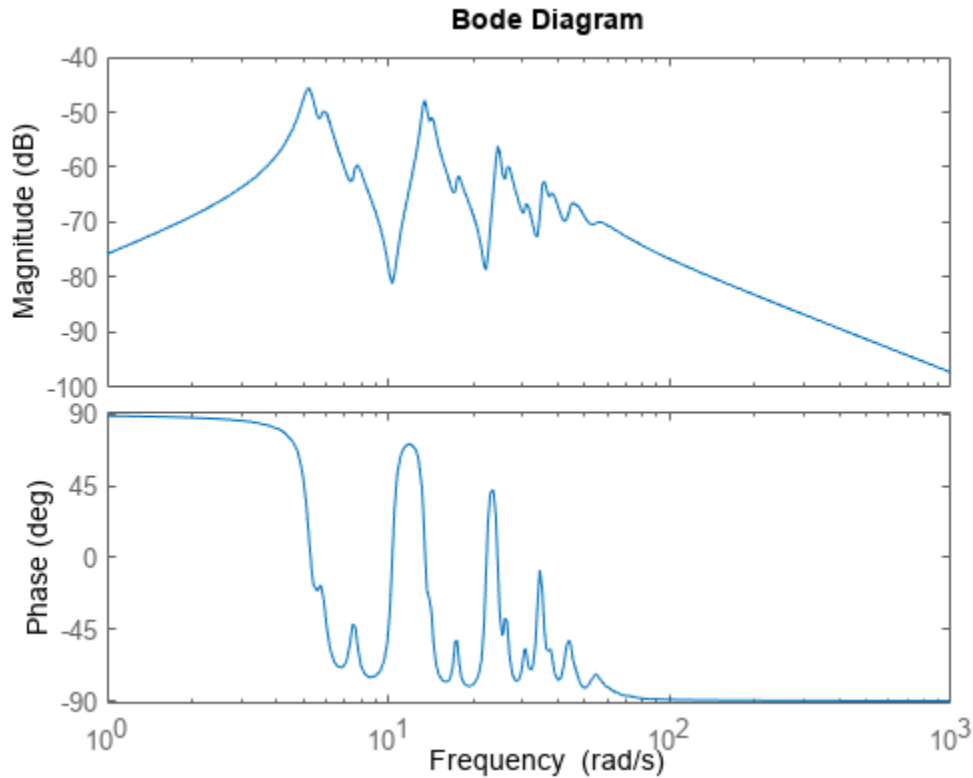

G is a 48th-order model with several large peak regions around 5.2 rad/s, 13.5 rad/s, and 24.5 rad/s, and smaller peaks scattered across many frequencies. Suppose that for your application you are only interested in the dynamics near the second large peak, between 10 rad/s and 22 rad/s. Focus the model reduction on the region of interest to obtain a good match with a low-order approximation. Use `balredOptions` to specify the frequency interval for `balred`.

```
bopt = balredOptions('StateProjection','Truncate','FreqIntervals',[10,22]);
GLim10 = balred(G,10,bopt);
GLim18 = balred(G,18,bopt);
```

Examine the frequency responses of the reduced-order models. Also, examine the difference between those responses and the original response (the absolute error).

```
subplot(2,1,1);
bodemag(G,GLim10,GLim18,logspace(0.5,1.5,100));
title('Bode Magnitude Plot');
legend('Original','Order 10','Order 18');
subplot(2,1,2);
bodemag(G-GLim10,G-GLim18,logspace(0.5,1.5,100));
title('Absolute Error Plot');
legend('Order 10','Order 18');
```

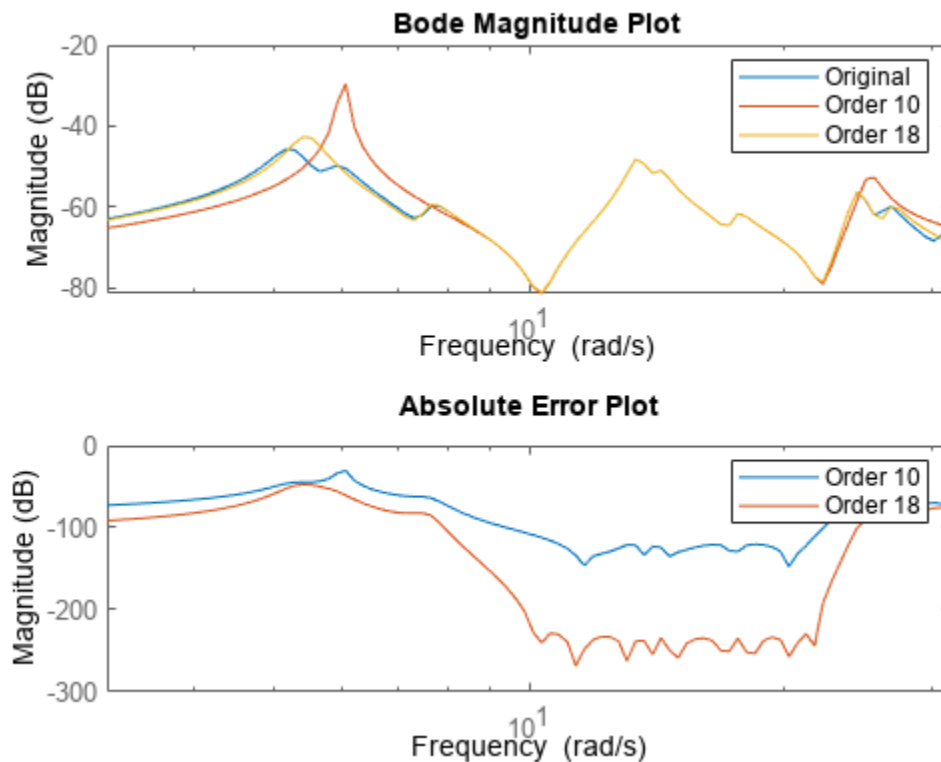

With the frequency-limited energy computation, even the 10th-order approximation is quite good in the region of interest.

Model-Order Reduction with Relative Error Approximation

For this example, consider the SISO state-space model `cdrom` with 120 states. You can use absolute or relative error control when approximating models with `balred`. This example compares the two approaches when applied to a 120-state model of a portable CD player device `cdrom` [1,2] on page 2-52.

Load the CD player model `cdrom`.

```
load cdromData.mat cdrom
size(cdrom)
```

State-space model with 1 outputs, 1 inputs, and 120 states.

To compare results with absolute vs. relative error control, create one option set for each approach.

```
opt_abs = balredOptions('ErrorBound','absolute','StateProjection','truncate');
opt_rel = balredOptions('ErrorBound','relative','StateProjection','truncate');
```

Compute reduced-order models of order 15 with both approaches.

```
rsys_abs = balred(cdrom,15,opt_abs);
rsys_rel = balred(cdrom,15,opt_rel);
size(rsys_abs)
```

State-space model with 1 outputs, 1 inputs, and 15 states.

```
size(rsys_rel)
```

State-space model with 1 outputs, 1 inputs, and 15 states.

Plot the Bode response of the original model along with the absolute-error and relative-error reduced models.

```
bo = bodeoptions;
bo.PhaseMatching = 'on';
bodeplot(cdrom,'b.',rsys_abs,'r',rsys_rel,'g',bo)
legend('Original (120 states)', 'Absolute Error (15 states)', 'Relative Error (15 states)')
```

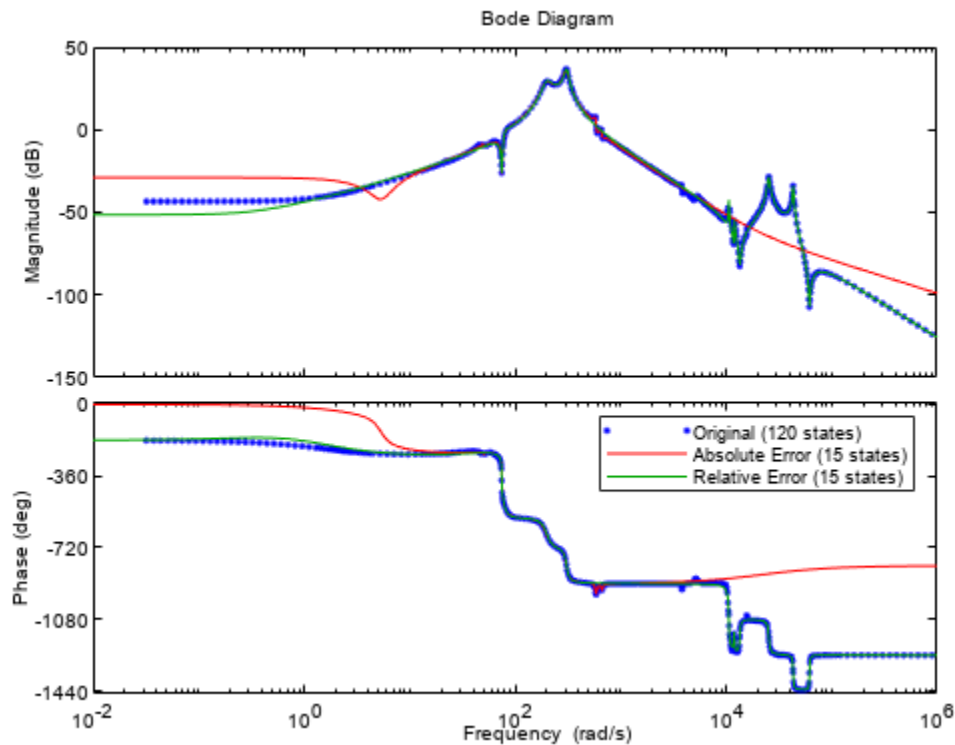

Observe that the Bode response of:

- The relative-error reduced model `rsys_rel` nearly matches the response of the original model `sys` across the complete frequency range.
- The absolute-error reduced model `rsys_abs` matches the response of the original model `sys` only in areas with the most gain.

References

- 1 [Benchmark Examples for Model Reduction](#), Subroutine Library in Systems and Control Theory (SLICOT). The CDROM data set is reproduced with permission, see BSD3-license for details.
- 2 A.Varga, "On stochastic balancing related model reduction", *Proceedings of the 39th IEEE Conference on Decision and Control (Cat. No.00CH37187)*, Sydney, NSW, 2000, pp. 2385-2390 vol.3, doi: 10.1109/CDC.2000.914156.

Algorithms

The `SepTol` and `Offset` options are only used for models with unstable or marginally stable dynamics. Because Hankel singular values (HSV) are only meaningful for stable dynamics, `balred` must first split such models into the sum of their stable and unstable parts:

$$G = G_s + G_u$$

This decomposition can be tricky when the model has modes close to the stability boundary (e.g., a pole at $s = -1e-10$), or clusters of modes on the stability boundary (e.g., double or triple integrators). While `balred` is able to overcome these difficulties in most cases, it sometimes produces unexpected results such as

- 1 Large HSV for the stable part. This happens when the stable part G_s contains some poles very close to the stability boundary. To force such modes into the unstable group, increase the `'Offset'` option to slightly grow the unstable region.
- 2 Too many modes are labeled "unstable." For example, you see 5 red bars in the HSV plot when your model had only 2 unstable poles. The stable/unstable decomposition algorithm has built-in accuracy checks that reject decompositions causing a significant loss of accuracy in the frequency response. For instance, such loss of accuracy arises when trying to split a cluster of stable and unstable modes near $s = 0$. Because such clusters are numerically equivalent to multiple poles at $s = 0$, it is actually desirable to treat the whole cluster as unstable. In some cases, however, large relative errors in low-gain frequency bands can trip the accuracy checks and lead to a rejection of valid decompositions. Additional modes are then absorbed into the unstable part G_u , unduly increasing its order. Such issues can be easily corrected by adjusting the `SepTol` tolerance.

If you use the `TimeIntervals` or `FreqIntervals` options, then `balred` bases the computation of state energy contributions on time-limited or frequency-limited controllability and observability Gramians. For information about calculating time-limited and frequency-limited Gramians, see `gram` and [1].

Version History

Introduced in R2010a

MatchDC option honored when specified frequency or time intervals exclude DC

Behavior changed in R2017b

When you use `balred` for model reduction, you can use `balredOptions` to restrict the computation to specified frequency or time intervals. If the `StateProjection` option of `balredOptions` is set to `'MatchDC'` (the default value), then `balred` attempts to match the DC gain of the original and reduced models, even if the specified intervals exclude DC (frequency = 0 or time = Inf).

Prior to R2017b, if you specified time or frequency intervals that excluded DC, `balred` did not attempt to match the DC gain of the original and reduced models, even if `StateProjection = 'MatchDC'`.

References

- [1] Gawronski, W. and J.N. Juang. "Model Reduction in Limited Time and Frequency Intervals." *International Journal of Systems Science*. Vol. 21, Number 2, 1990, pp. 349-376.

See Also

`gramOptions` | `balred` | `stabsep`

Topics

"Balanced Truncation Model Reduction"

bandwidth

Frequency response bandwidth

Syntax

```
fb = bandwidth(sys)
fb = bandwidth(sys,dbdrop)
```

Description

`fb = bandwidth(sys)` returns the bandwidth of the SISO dynamic system model `sys`. The bandwidth is the first frequency where the gain drops below 70.79% (-3 dB) of its DC value. The bandwidth is expressed in rad/TimeUnit, where TimeUnit is the TimeUnit property of `sys`.

`fb = bandwidth(sys,dbdrop)` returns the bandwidth for a specified gain drop.

Examples

Compute System Bandwidth

Compute the bandwidth of the transfer function $sys = 1/(s+1)$.

```
sys = tf(1,[1 1]);
fb = bandwidth(sys)
```

```
fb = 0.9976
```

This result shows that the gain of `sys` drops to 3 dB below its DC value at around 1 rad/s.

Find Bandwidth of System with Custom Gain Drop

Compute the frequency at which the gain of a system drops to 3.5 dB below its DC value. Create a state-space model.

```
A = [-2, -1; 1, 0];
B = [1; 0];
C = [1, 2];
D = 1;
sys = ss(A,B,C,D);
```

Find the 3.5 dB bandwidth of `sys`.

```
dbdrop = -3.5;
fb = bandwidth(sys,dbdrop)
```

```
fb = 0.8348
```

Find Bandwidth of Model Array

Find the bandwidth of each entry in a 5-by-1 array of transfer function models. Use a `for` loop to create the array, and confirm its dimensions.

```
sys = tf(zeros(1,1,5));  
s = tf('s');  
for m = 1:5  
    sys(:,:,m) = m/(s^2+s+m);  
end  
size(sys)
```

```
5x1 array of transfer functions.  
Each model has 1 outputs and 1 inputs.
```

Find the bandwidths.

```
fb = bandwidth(sys)
```

```
fb = 5×1  
  
    1.2712  
    1.9991  
    2.5298  
    2.9678  
    3.3493
```

`bandwidth` returns an array in which each entry is the bandwidth of the corresponding entry in `sys`. For instance, the bandwidth of `sys(:,:,2)` is `fb(2)`.

Input Arguments

sys — Dynamic system

dynamic system model | model array

Dynamic system, specified as a SISO dynamic system model or an array of SISO dynamic system models. Dynamic systems that you can use include:

- Continuous-time or discrete-time numeric LTI models such as `tf`, `zpk`, or `ss` models.
- Frequency-response data models such as `frd` models. For such models, `bandwidth` uses the first frequency point to approximate the DC gain.

If `sys` is an array of models, `bandwidth` returns an array of the same size, where each entry is the bandwidth of the corresponding model in `sys`. For more information on model arrays, see “Model Arrays”.

dbdrop — Gain drop

-3 (default) | negative scalar

Gain drop in dB, specified as a real negative scalar.

Output Arguments

fb — Frequency response bandwidth

scalar | array

Frequency response bandwidth, returned as a scalar or an array. If `sys` is:

- A single model, then `fb` is the bandwidth of `sys`.
- A model array, then `fb` is an array of the same size as the model array `sys`. Each entry is the bandwidth of the corresponding entry in `sys`.

`fb` is expressed in `rad/TimeUnit`, where `TimeUnit` is the `TimeUnit` property of `sys`.

Version History

Introduced before R2006a

See Also

`dcgain` | `issiso` | `bodeplot`

bdschur

Block-diagonal Schur factorization

Syntax

```
[T,B,BLKS] = bdschur(A,CONDMAX)
[T,B] = bdschur(A,[],BLKS)
```

Description

`[T,B,BLKS] = bdschur(A,CONDMAX)` computes a transformation matrix T such that $B = T \setminus A * T$ is block diagonal and each diagonal block is a quasi upper-triangular Schur matrix.

`[T,B] = bdschur(A,[],BLKS)` pre-specifies the desired block sizes. The input matrix A should already be in Schur form when you use this syntax.

Input Arguments

- A : Matrix for block-diagonal Schur factorization.
- $CONDMAX$: Specifies an upper bound on the condition number of T . By default, $CONDMAX = 1e4$. Use $CONDMAX$ to control the tradeoff between block size and conditioning of T with respect to inversion. When $CONDMAX$ is a larger value, the blocks are smaller and T becomes more ill-conditioned.

Output Arguments

- T : Transformation matrix.
- B : Matrix $B = T \setminus A * T$.
- $BLKS$: Vector of block sizes.

Version History

Introduced in R2008a

Default value of $CONDMAX$ input argument changed

Behavior changed in R2022a

The default value of $CONDMAX$ input argument is now $1e4$. Previously, the default value was $1/\text{sqrt}(\text{eps})$. Increasing $CONDMAX$ reduces the size of the eigenvalue clusters in the transformed model but also decreases the accuracy of the transformation. The new default value balances the conditioning and transformation accuracy. If you have code that relies on the default value of $CONDMAX$ being $1/\text{sqrt}(\text{eps})$, update your code to explicitly set this input argument.

See Also

`ordschur` | `schur`

blkdiag

Block-diagonal concatenation of models

Syntax

```
sys = blkdiag(sys1,sys2,...,sysN)
```

Description

`sys = blkdiag(sys1,sys2,...,sysN)` produces the aggregate system

$$\begin{bmatrix} \text{sys1} & 0 & \dots & 0 \\ 0 & \text{sys2} & & : \\ : & . & . & 0 \\ 0 & \dots & 0 & \text{sysN} \end{bmatrix}$$

`blkdiag` is equivalent to `append`.

Examples

Perform Block-Diagonal Concatenation

Perform block-diagonal concatenation of a transfer function model and a state-space model.

Create the SISO continuous-time transfer function model, $1/s$.

```
sys1 = tf(1,[1 0]);
```

Create a SISO continuous-time state-space model with state-space matrices 1,2,3, and 4.

```
sys2 = ss(1,2,3,4);
```

Concatenate `sys1`, a SISO static gain system, and `sys2`. The resulting model is a 3-input, 3-output state-space model.

```
sys = blkdiag(sys1,10,sys2)
```

```
sys =
```

```
A =
      x1  x2
x1    0   0
x2    0   1
```

```
B =
      u1  u2  u3
x1    1   0   0
x2    0   0   2
```

```
C =
```

```
      x1  x2
y1    1   0
y2    0   0
y3    0   3
```

```
D =
      u1  u2  u3
y1    0   0   0
y2    0  10   0
y3    0   0   4
```

Continuous-time state-space model.

Alternatively, use the `append` command.

```
sys = append(sys1,10,sys2);
```

Version History

Introduced in R2009a

See Also

`append` | `series` | `parallel` | `feedback`

bode

Bode plot of frequency response, or magnitude and phase data

Syntax

```
bode(sys)
bode(sys1,sys2,...,sysN)
bode(sys1,LineStyle1,...,sysN,LineStyleN)
bode( __ ,w)

[mag,phase,wout] = bode(sys)
[mag,phase,wout] = bode(sys,w)
[mag,phase,wout,sdmag,sdphase] = bode(sys,w)
```

Description

`bode(sys)` creates a Bode plot of the frequency response of a dynamic system model `sys`. The plot displays the magnitude (in dB) and phase (in degrees) of the system response as a function of frequency. `bode` automatically determines frequencies to plot based on system dynamics.

If `sys` is a multi-input, multi-output (MIMO) model, then `bode` produces an array of Bode plots, each plot showing the frequency response of one I/O pair.

If `sys` is a model with complex coefficients, then in:

- Log frequency scale, the plot shows two branches, one for positive frequencies and one for negative frequencies. The plot also shows arrows to indicate the direction of increasing frequency values for each branch. See “Bode Plot of Model with Complex Coefficients” on page 2-70.
- Linear frequency scale, the plot shows a single branch with a symmetric frequency range centered at a frequency value of zero.

`bode(sys1,sys2,...,sysN)` plots the frequency response of multiple dynamic systems on the same plot. All systems must have the same number of inputs and outputs.

`bode(sys1,LineStyle1,...,sysN,LineStyleN)` specifies a color, line style, and marker for each system in the plot.

`bode(__ ,w)` plots system responses for frequencies specified by `w`.

- If `w` is a cell array of the form `{wmin,wmax}`, then `bode` plots the response at frequencies ranging between `wmin` and `wmax`.
- If `w` is a vector of frequencies, then `bode` plots the response at each specified frequency. The vector `w` can contain both negative and positive frequencies.

You can use `w` with any of the input-argument combinations in previous syntaxes.

`[mag,phase,wout] = bode(sys)` returns the magnitude and phase of the response at each frequency in the vector `wout`. The function automatically determines frequencies in `wout` based on system dynamics. This syntax does not draw a plot.

`[mag,phase,wout] = bode(sys,w)` returns the response data at the frequencies specified by `w`.

- If `w` is a cell array of the form `{wmin,wmax}`, then `wout` contains frequencies ranging between `wmin` and `wmax`.
- If `w` is a vector of frequencies, then `wout = w`.

`[mag,phase,wout,sdmag,sdphase] = bode(sys,w)` also returns the estimated standard deviation of the magnitude and phase values for the identified model `sys`. If you omit `w`, then the function automatically determines frequencies in `wout` based on system dynamics.

Examples

Bode Plot of Dynamic System

Create a Bode plot of the following continuous-time SISO dynamic system.

$$H(s) = \frac{s^2 + 0.1s + 7.5}{s^4 + 0.12s^3 + 9s^2}$$

```
H = tf([1 0.1 7.5],[1 0.12 9 0 0]);
bode(H)
```

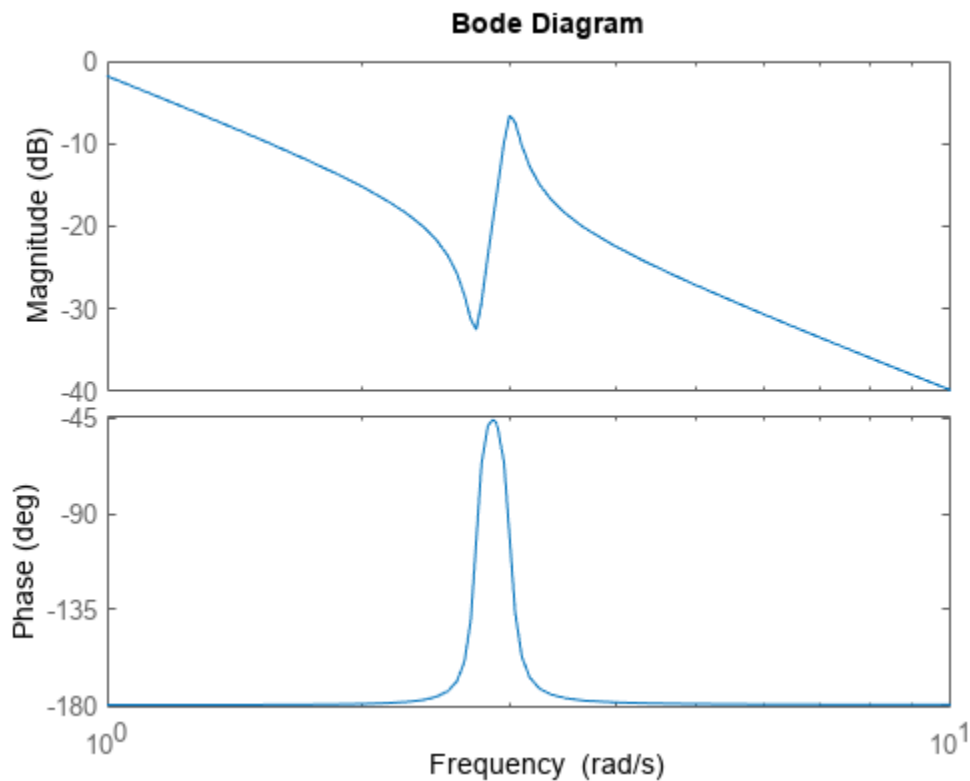

`bode` automatically selects the plot range based on the system dynamics.

Bode Plot at Specified Frequencies

Create a Bode plot over a specified frequency range. Use this approach when you want to focus on the dynamics in a particular range of frequencies.

```
H = tf([-0.1, -2.4, -181, -1950], [1, 3.3, 990, 2600]);
bode(H, {1, 100})
grid on
```

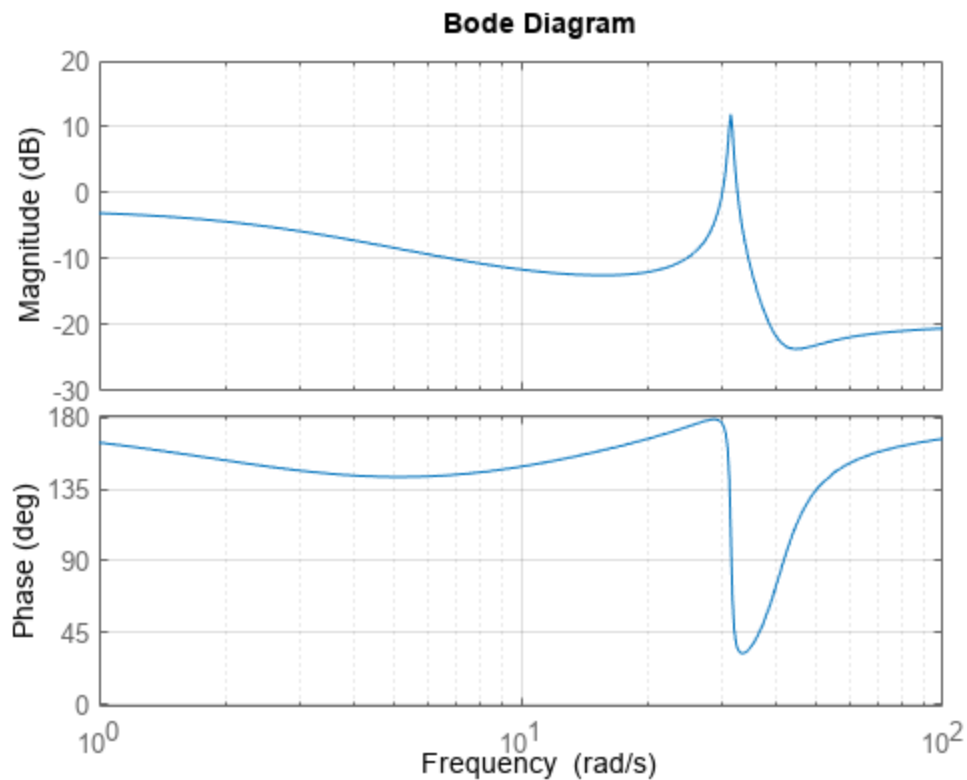

The cell array `{1, 100}` specifies the minimum and maximum frequency values in the Bode plot. When you provide frequency bounds in this way, the function selects intermediate points for frequency response data.

Alternatively, specify a vector of frequency points to use for evaluating and plotting the frequency response.

```
w = [1 5 10 15 20 23 31 40 44 50 85 100];
bode(H,w, '-.-')
grid on
```

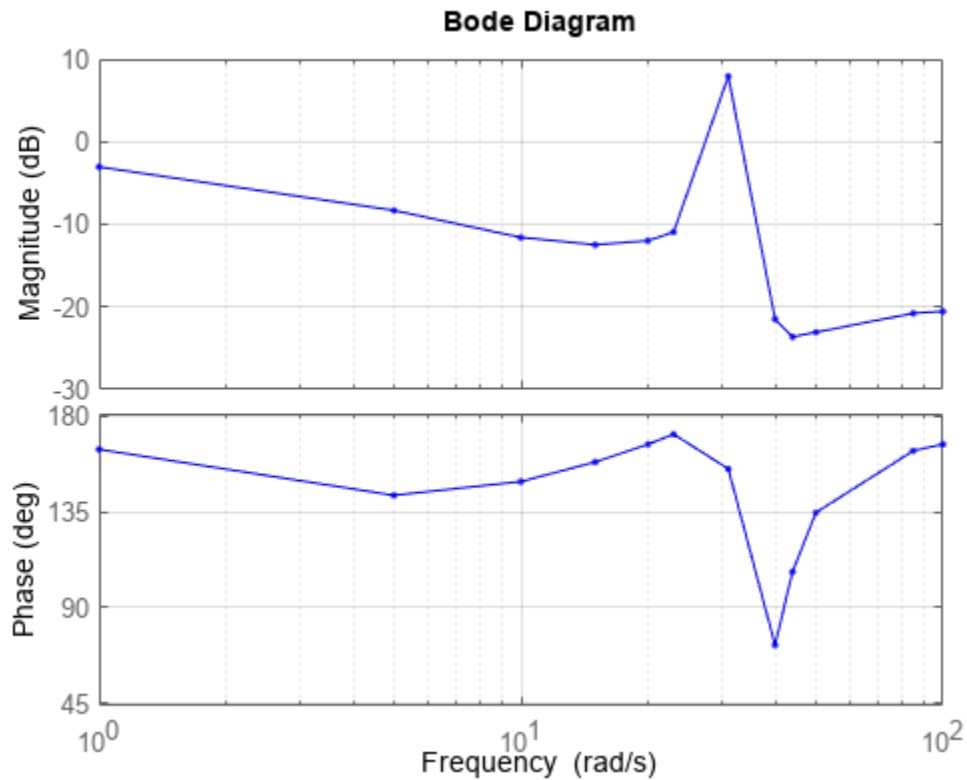

bode plots the frequency response at the specified frequencies only.

Compare Bode Plots of Several Dynamic Systems

Compare the frequency response of a continuous-time system to an equivalent discretized system on the same Bode plot.

Create continuous-time and discrete-time dynamic systems.

```
H = tf([1 0.1 7.5],[1 0.12 9 0 0]);
Hd = c2d(H,0.5,'zoh');
```

Create a Bode plot that displays both systems.

```
bode(H,Hd)
```

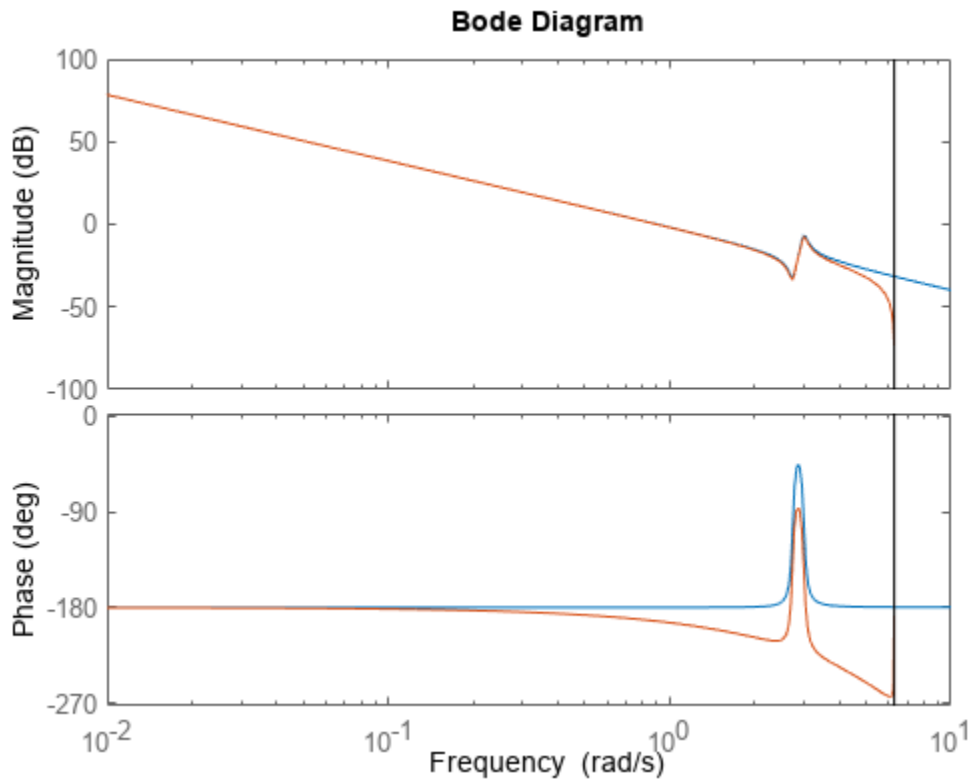

The Bode plot of a discrete-time system includes a vertical line marking the Nyquist frequency of the system.

Bode Plot with Specified Line Attributes

Specify the line style, color, or marker for each system in a Bode plot using the `LineStyle` input argument.

```
H = tf([1 0.1 7.5],[1 0.12 9 0 0]);
Hd = c2d(H,0.5,'zoh');
bode(H,'r',Hd,'b--')
```

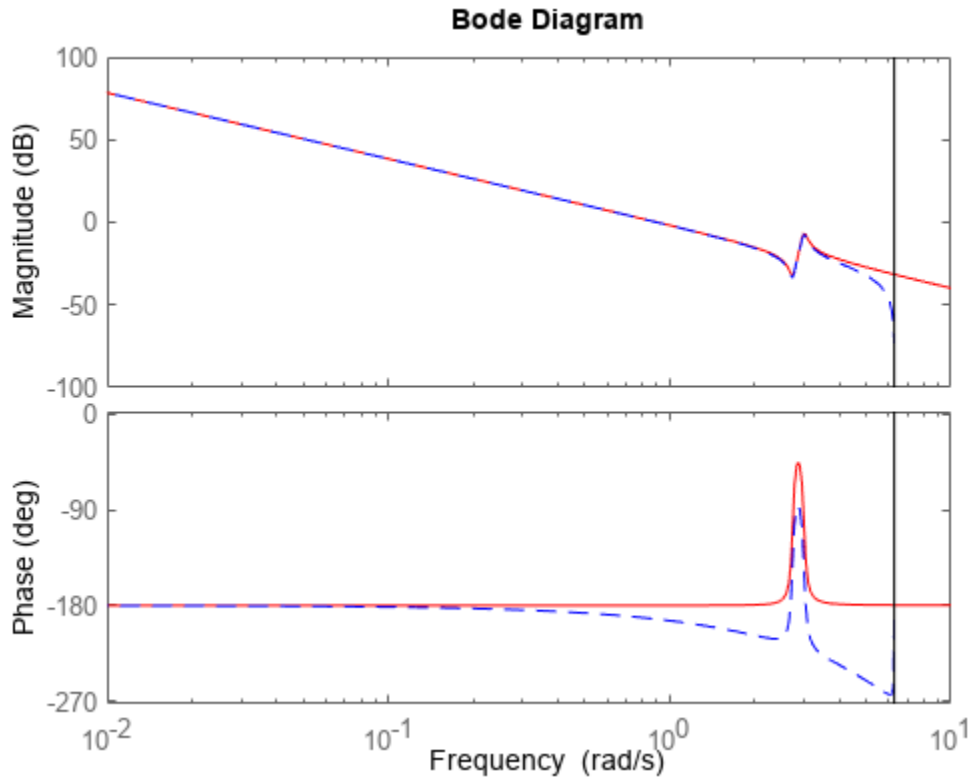

The first `LineStyle`, 'r', specifies a solid red line for the response of H . The second `LineStyle`, 'b--', specifies a dashed blue line for the response of H_d .

Obtain Magnitude and Phase Data

Compute the magnitude and phase of the frequency response of a SISO system.

If you do not specify frequencies, `bode` chooses frequencies based on the system dynamics and returns them in the third output argument.

```
H = tf([1 0.1 7.5],[1 0.12 9 0 0]);
[mag,phase,wout] = bode(H);
```

Because H is a SISO model, the first two dimensions of `mag` and `phase` are both 1. The third dimension is the number of frequencies in `wout`.

```
size(mag)
```

```
ans = 1×3
```

```
1 1 41
```

```
length(wout)
```

```
ans = 41
```

Thus, each entry along the third dimension of `mag` gives the magnitude of the response at the corresponding frequency in `wout`.

Magnitude and Phase of MIMO System

For this example, create a 2-output, 3-input system.

```
rng(0, 'twister'); % For reproducibility
H = rss(4,2,3);
```

For this system, `bode` plots the frequency responses of each I/O channel in a separate plot in a single figure.

```
bode(H)
```

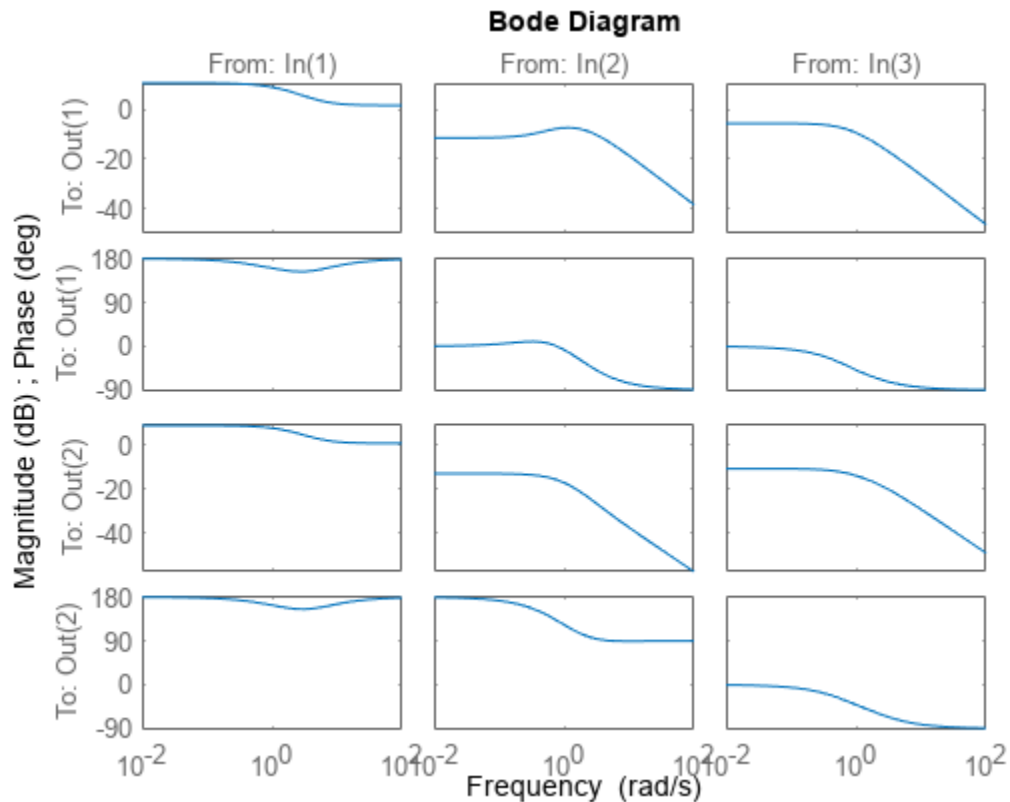

Compute the magnitude and phase of these responses at 20 frequencies between 1 and 10 radians.

```
w = logspace(0,1,20);
[mag,phase] = bode(H,w);
```

`mag` and `phase` are three-dimensional arrays, in which the first two dimensions correspond to the output and input dimensions of `H`, and the third dimension is the number of frequencies. For instance, examine the dimensions of `mag`.

```
size(mag)
ans = 1×3
      2      3     20
```

Thus, for example, `mag(1,3,10)` is the magnitude of the response from the third input to the first output, computed at the 10th frequency in `w`. Similarly, `phase(1,3,10)` contains the phase of the same response.

Bode Plot of Identified Model

Compare the frequency response of a parametric model, identified from input/output data, to a nonparametric model identified using the same data.

Identify parametric and nonparametric models based on data.

```
load iddata2 z2;
w = linspace(0,10*pi,128);
sys_np = spa(z2,[],w);
sys_p = tfest(z2,2);
```

Using the `spa` and `tfest` commands requires System Identification Toolbox™ software.

`sys_np` is a nonparametric identified model. `sys_p` is a parametric identified model.

Create a Bode plot that includes both systems.

```
bode(sys_np,sys_p,w);
legend('sys-np','sys-p')
```

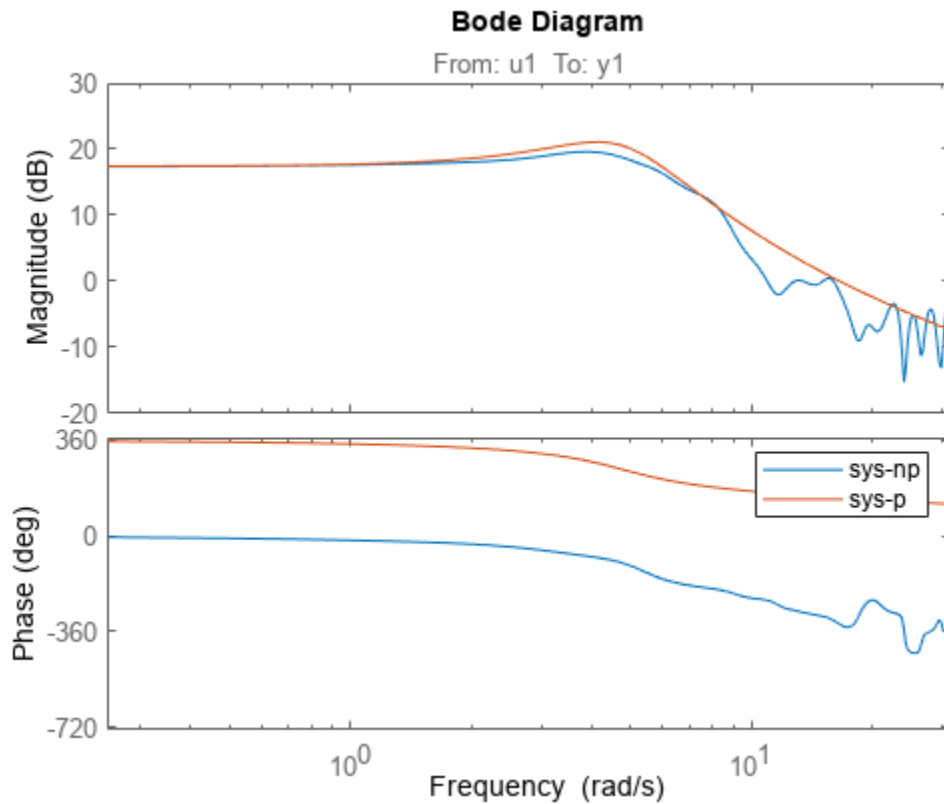

You can display the confidence region on the Bode plot by right-clicking the plot and selecting **Characteristics > Confidence Region**.

Obtain Magnitude and Phase Standard Deviation Data of Identified Model

Compute the standard deviation of the magnitude and phase of an identified model. Use this data to create a 3σ plot of the response uncertainty.

Identify a transfer function model based on data. Obtain the standard deviation data for the magnitude and phase of the frequency response.

```
load iddata2 z2;
sys_p = tfest(z2,2);
w = linspace(0,10*pi,128);
[mag,ph,w,sdmag,sdphase] = bode(sys_p,w);
```

Using the `tfest` command requires System Identification Toolbox™ software.

`sys_p` is an identified transfer function model. `sdmag` and `sdphase` contain the standard deviation data for the magnitude and phase of the frequency response, respectively.

Use the standard deviation data to create a 3σ plot corresponding to the confidence region.

```

mag = squeeze(mag);
sdmag = squeeze(sdmag);
semilogx(w,mag,'b',w,mag+3*sdmag,'k:',w,mag-3*sdmag,'k:');

```

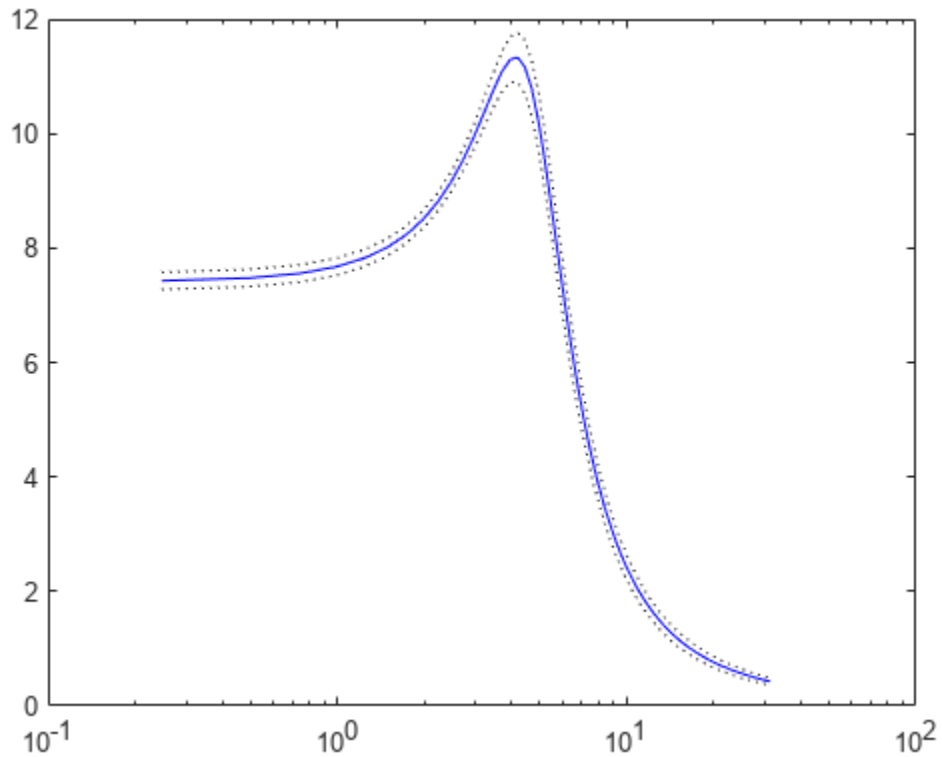

Bode Plot of Model with Complex Coefficients

Create a Bode plot of a model with complex coefficients and a model with real coefficients on the same plot.

```

rng(0)
A = [-3.50, -1.25-0.25i; 2, 0];
B = [1; 0];
C = [-0.75-0.5i, 0.625-0.125i];
D = 0.5;
Gc = ss(A,B,C,D);
Gr = rss(5);
bode(Gc,Gr)
legend('Complex-coefficient model','Real-coefficient model','Location','southwest')

```

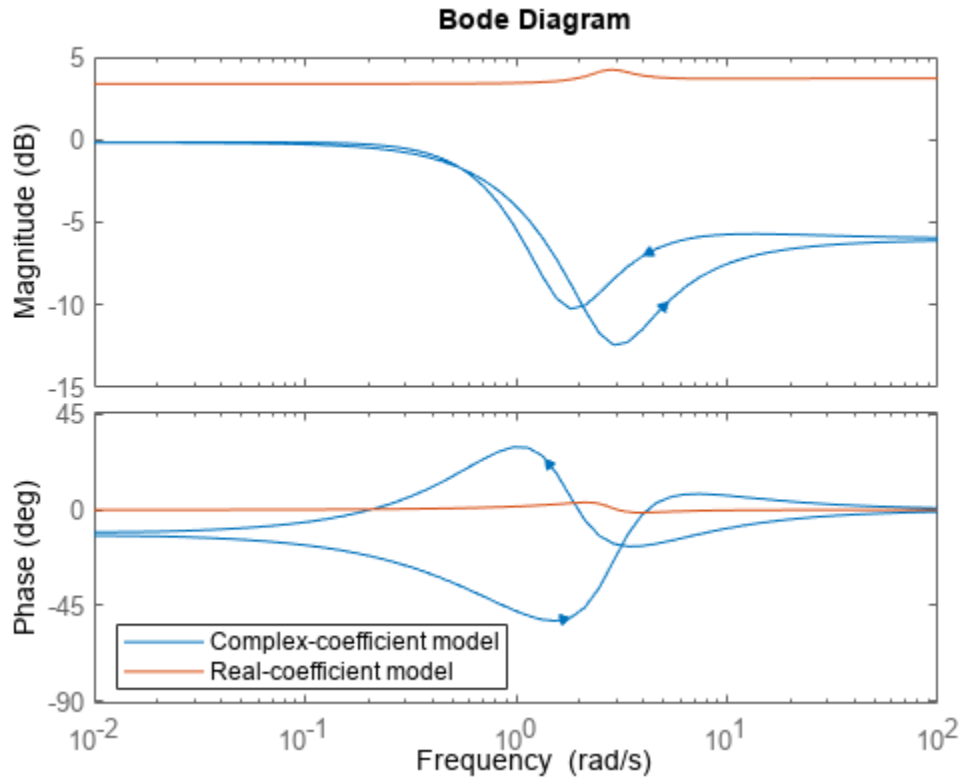
In log frequency scale, the plot shows two branches for complex-coefficient models, one for positive frequencies, with a right-pointing arrow, and one for negative frequencies, with a left-pointing arrow. In both branches, the arrows indicate the direction of increasing frequencies. The plots for real-coefficient models always contain a single branch with no arrows.

You can change the frequency scale of the Bode plot by right-clicking the plot and selecting **Properties**. In the Property Editor dialog, on the **Units** tab, set the frequency scale to `linear` scale. Alternatively, you can use the `bodeplot` function with a `bodeoptions` object to create a customized plot.

```
opt = bodeoptions;
opt.FreqScale = 'Linear';
```

Create the plot with customized options.

```
bodeplot(Gc,Gr,opt)
legend('Complex-coefficient model','Real-coefficient model','Location','southwest')
```

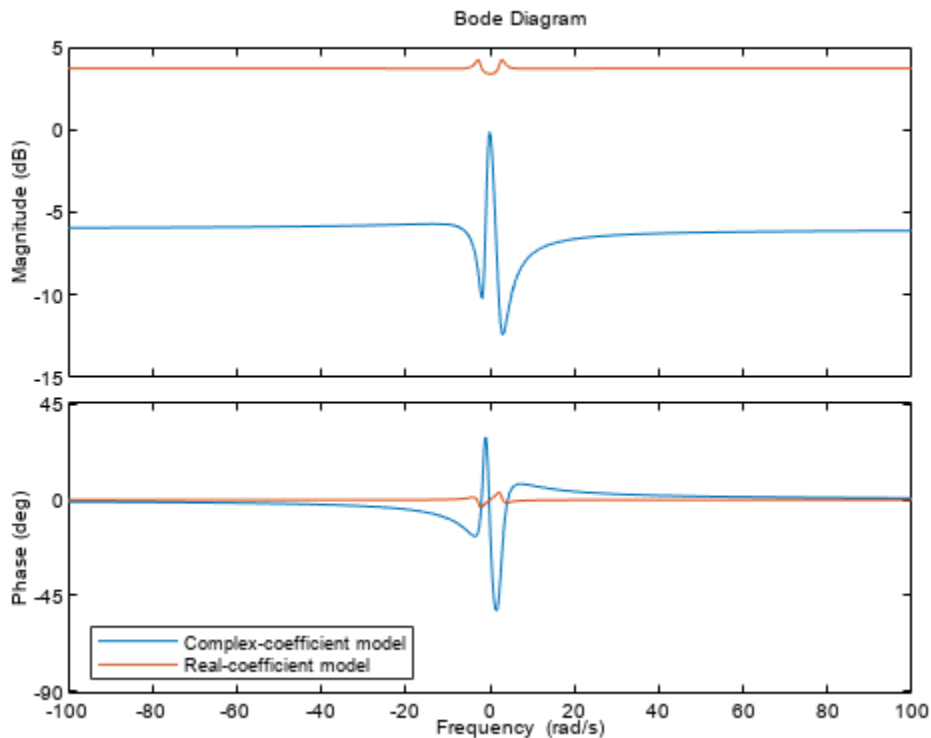

In linear frequency scale, the plot shows a single branch with a symmetric frequency range centered at a frequency value of zero. The plot also shows the negative-frequency response of a real-coefficient model when you plot the response along with a complex-coefficient model.

Input Arguments

sys — Dynamic system

dynamic system model | model array

Dynamic system, specified as a SISO or MIMO dynamic system model or array of dynamic system models. Dynamic systems that you can use include:

- Continuous-time or discrete-time numeric LTI models, such as `tf`, `zpk`, or `ss` models.
- Generalized or uncertain LTI models such as `genss` or `uss` models. (Using uncertain models requires Robust Control Toolbox software.)
 - For tunable control design blocks, the function evaluates the model at its current value for both plotting and returning frequency response data.
 - For uncertain control design blocks, the function plots the nominal value and random samples of the model. When you use output arguments, the function returns frequency response data for the nominal model only.
- Frequency-response data models such as `frd` models. For such models, the function plots the response at frequencies defined in the model.

- Identified LTI models, such as `idtf`, `idss`, or `idproc` models. For such models, the function can also plot confidence intervals and return standard deviations of the frequency response. See “Bode Plot of Identified Model” on page 2-68. (Using identified models requires System Identification Toolbox™ software.)

If `sys` is an array of models, the function plots the frequency responses of all models in the array on the same axes.

LineStyle — Line style, marker, and color

character vector | string

Line style, marker, and color, specified as a string or vector of one, two, or three characters. The characters can appear in any order. You do not need to specify all three characteristics (line style, marker, and color). For example, if you omit the line style and specify the marker, then the plot shows only the marker and no line. For more information about configuring this argument, see the `LineStyle` input argument of the `plot` function.

Example: `'r--'` specifies a red dashed line

Example: `'*b'` specifies blue asterisk markers

Example: `'y'` specifies a yellow line

w — Frequencies

{`wmin`,`wmax`} | vector

Frequencies at which to compute and plot frequency response, specified as the cell array `{wmin,wmax}` or as a vector of frequency values.

- If `w` is a cell array of the form `{wmin,wmax}`, then the function computes the response at frequencies ranging between `wmin` and `wmax`.
- If `w` is a vector of frequencies, then the function computes the response at each specified frequency. For example, use `logspace` to generate a row vector with logarithmically spaced frequency values. The vector `w` can contain both positive and negative frequencies.

For models with complex coefficients, if you specify a frequency range of `[wmin,wmax]` for your plot, then in:

- Log frequency scale, the plot frequency limits are set to `[wmin,wmax]` and the plot shows two branches, one for positive frequencies `[wmin,wmax]` and one for negative frequencies `[-wmax,-wmin]`.
- Linear frequency scale, the plot frequency limits are set to `[-wmax,wmax]` and the plot shows a single branch with a symmetric frequency range centered at a frequency value of zero.

Specify frequencies in units of `rad/TimeUnit`, where `TimeUnit` is the `TimeUnit` property of the model.

Output Arguments

mag — Magnitude of system response

3-D array

Magnitude of the system response in absolute units, returned as a 3-D array. The dimensions of this array are (number of system outputs) × (number of system inputs) × (number of frequency points).

- For SISO systems, `mag(1, 1, k)` gives the magnitude of the response at the *k*th frequency in `w` or `wout`. For an example, see “Obtain Magnitude and Phase Data” on page 2-66.
- For MIMO systems, `mag(i, j, k)` gives the magnitude of the response at the *k*th frequency from the *j*th input to the *i*th output. For an example, see “Magnitude and Phase of MIMO System” on page 2-67.

To convert the magnitude from absolute units to decibels, use:

```
magdb = 20*log10(mag)
```

phase — Phase of system response

3-D array

Phase of the system response in degrees, returned as a 3-D array. The dimensions of this array are (number of outputs) × (number of inputs) × (number of frequency points).

- For SISO systems, `phase(1, 1, k)` gives the phase of the response at the *k*th frequency in `w` or `wout`. For an example, see “Obtain Magnitude and Phase Data” on page 2-66.
- For MIMO systems, `phase(i, j, k)` gives the phase of the response at the *k*th frequency from the *j*th input to the *i*th output. For an example, see “Magnitude and Phase of MIMO System” on page 2-67.

wout — Frequencies

vector

Frequencies at which the function returns the system response, returned as a column vector. The function chooses the frequency values based on the model dynamics, unless you specify frequencies using the input argument `w`.

`wout` also contains negative frequency values for models with complex coefficients.

Frequency values are in radians/`TimeUnit`, where `TimeUnit` is the value of the `TimeUnit` property of `sys`.

sdmag — Standard deviation of magnitude

3-D array | []

Estimated standard deviation of the magnitude of the response at each frequency point, returned as a 3-D array. `sdmag` has the same dimensions as `mag`.

If `sys` is not an identified LTI model, `sdmag` is [].

sdphase — Standard deviation of phase

3-D array | []

Estimated standard deviation of the phase of the response at each frequency point, returned as a 3-D array. `sdphase` has the same dimensions as `phase`.

If `sys` is not an identified LTI model, `sdphase` is [].

Tips

- When you need additional plot customization options, use `bodeplot` instead.

Algorithms

`bode` computes the frequency response as follows:

- 1 Compute the zero-pole-gain (zpk) representation of the dynamic system.
- 2 Evaluate the gain and phase of the frequency response based on the zero, pole, and gain data for each input/output channel of the system.
 - For continuous-time systems, `bode` evaluates the frequency response on the imaginary axis $s = j\omega$ and considers only positive frequencies.
 - For discrete-time systems, `bode` evaluates the frequency response on the unit circle. To facilitate interpretation, the command parameterizes the upper half of the unit circle as:

$$z = e^{j\omega T_s}, \quad 0 \leq \omega \leq \omega_N = \frac{\pi}{T_s},$$

where T_s is the sample time and ω_N is the Nyquist frequency. The equivalent continuous-time frequency ω is then used as the x-axis variable. Because $H(e^{j\omega T_s})$ is periodic with period $2\omega_N$, `bode` plots the response only up to the Nyquist frequency ω_N . If `sys` is a discrete-time model with unspecified sample time, `bode` uses $T_s = 1$.

Version History

Introduced before R2006a

See Also

`bodeplot` | `freqresp` | `nichols` | `nyquist` | `step`

Topics

"Frequency-Domain Responses"

"Dynamic System Models"

External Websites

Transfer Function Analysis of Dynamic Systems (MathWorks Teaching Resources)

bodemag

Magnitude-only Bode plot of frequency response

Syntax

```
bodemag(sys)
bodemag(sys1,sys2,...,sysN)
bodemag(sys1,LineStyle1,...,sysN,LineStyleN)
bodemag( __ ,w)
```

Description

`bodemag` enables you to generate magnitude-only plots to visualize the magnitude frequency response of a dynamic system.

For a more comprehensive function, see `bode`. `bode` provides magnitude and phase information. If you have System Identification toolbox, `bode` also returns the computed values, including statistical estimates.

For more customizable plotting options, see `bodeplot`.

`bodemag(sys)` creates a Bode magnitude plot of the frequency response of the dynamic system model `sys`. The plot displays the magnitude (in dB) of the system response as a function of frequency. `bodemag` automatically determines frequencies to plot based on system dynamics.

If `sys` is a multi-input, multi-output (MIMO) model, then `bodemag` produces an array of Bode magnitude plots in which each plot shows the frequency response of one I/O pair.

`bodemag(sys1,sys2,...,sysN)` plots the frequency response of multiple dynamic systems on the same plot. All systems must have the same number of inputs and outputs.

`bodemag(sys1,LineStyle1,...,sysN,LineStyleN)` specifies a color, line style, and marker for each system in the plot.

`bodemag(__ ,w)` plots system responses for frequencies specified by `w`.

- If `w` is a cell array of the form `{wmin,wmax}`, then `bodemag` plots the response at frequencies ranging between `wmin` and `wmax`.
- If `w` is a vector of frequencies, then `bodemag` plots the response at each specified frequency.

You can use this syntax with any of the input-argument combinations in previous syntaxes.

Examples

Bode Magnitude Plot of Dynamic System

Create a Bode magnitude plot of the following continuous-time SISO dynamic system.

$$H(s) = \frac{s^2 + 0.1s + 7.5}{s^4 + 0.12s^3 + 9s^2}$$

```
H = tf([1 0.1 7.5],[1 0.12 9 0 0]);  
bodemag(H)
```

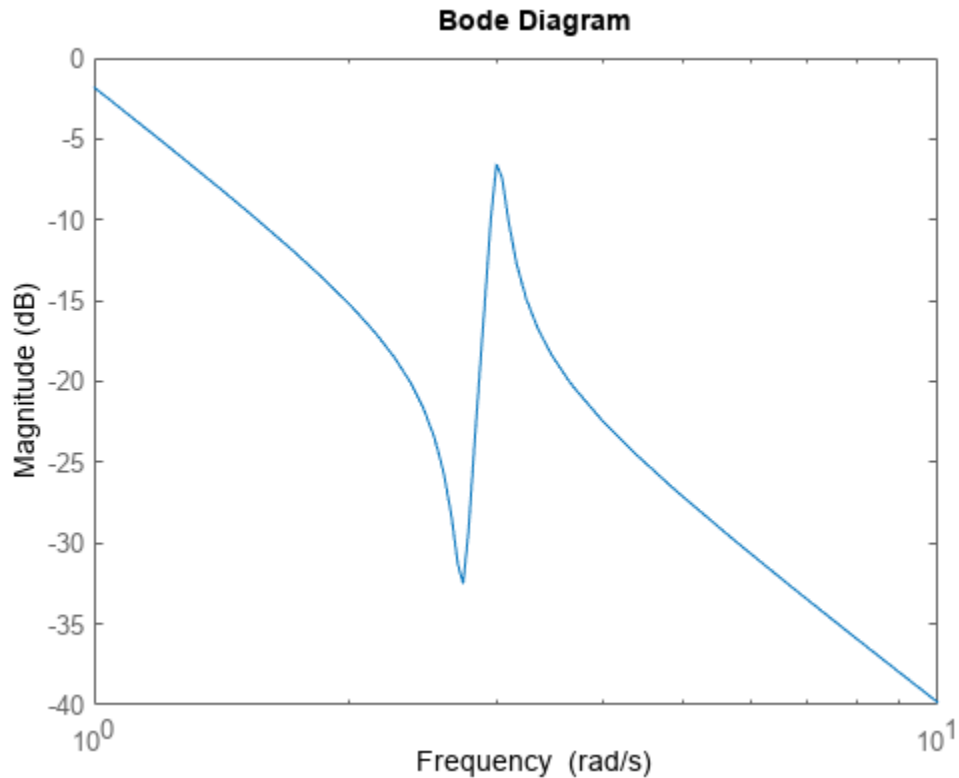

bodemag automatically selects the plot range based on the system dynamics.

Bode Magnitude Plot at Specified Frequencies

Create a Bode magnitude plot over a specified frequency range. Use this approach when you want to focus on the dynamics in a particular range of frequencies.

```
H = tf([-0.1, -2.4, -181, -1950], [1, 3.3, 990, 2600]);  
bodemag(H, {1, 100})  
grid on
```

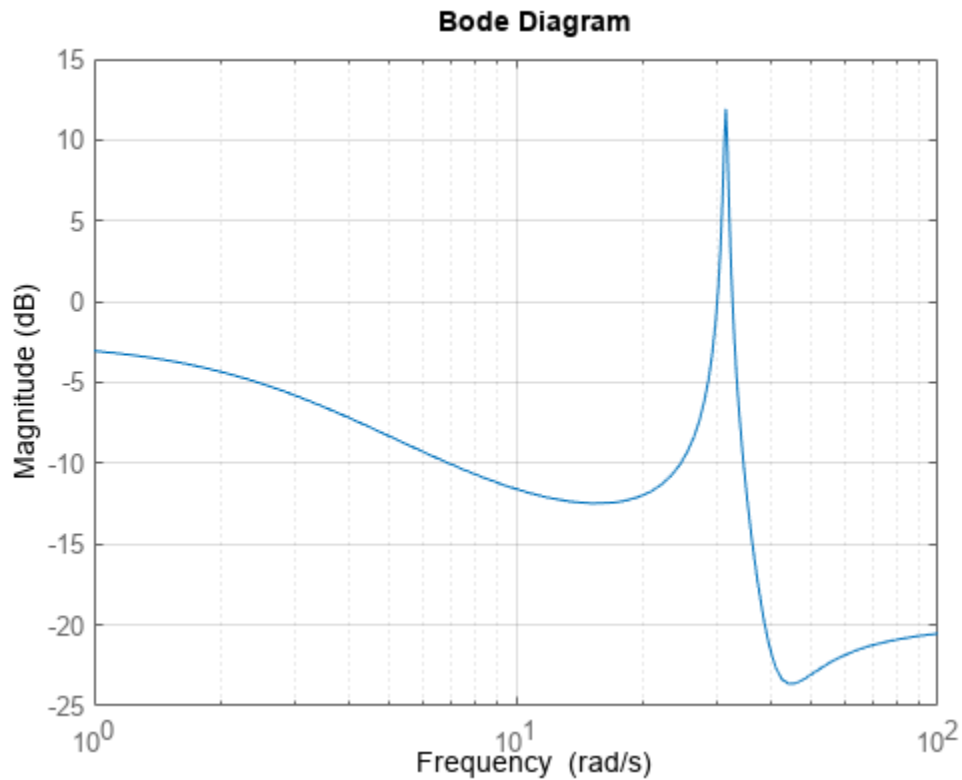

The cell array `{1, 100}` specifies the minimum and maximum frequency values in the Bode magnitude plot. When you provide frequency bounds in this way, the function selects intermediate points for frequency response data.

Alternatively, specify a vector of frequency points to use for evaluating and plotting the frequency response.

```
w = [1 5 10 15 20 23 31 40 44 50 85 100];  
bodemag(H,w, '-.-')  
grid on
```

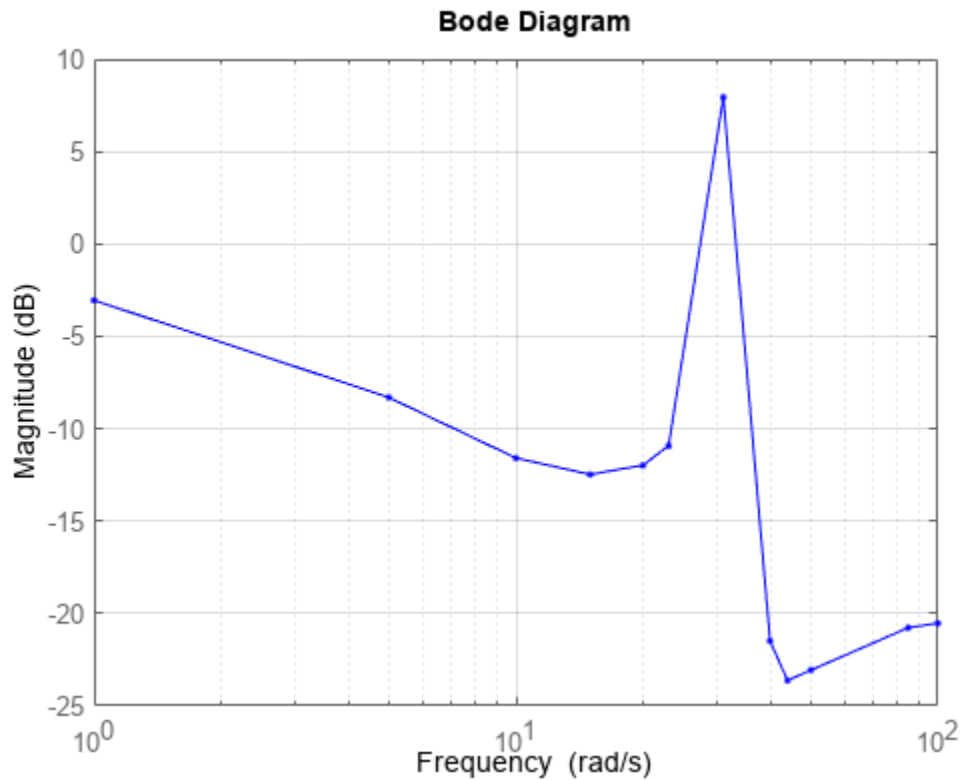
bodemag plots the frequency response at the specified frequencies only.

Compare Bode Magnitude Plots of Several Dynamic Systems

Compare the magnitude of the frequency response of a continuous-time system to an equivalent discretized system on the same Bode plot.

Create continuous-time and discrete-time dynamic systems.

```
H = tf([1 0.1 7.5],[1 0.12 9 0 0]);
Hd = c2d(H,0.5,'zoh');
```

Create a Bode magnitude plot that displays the responses of both systems.

```
bodemag(H,Hd)
```

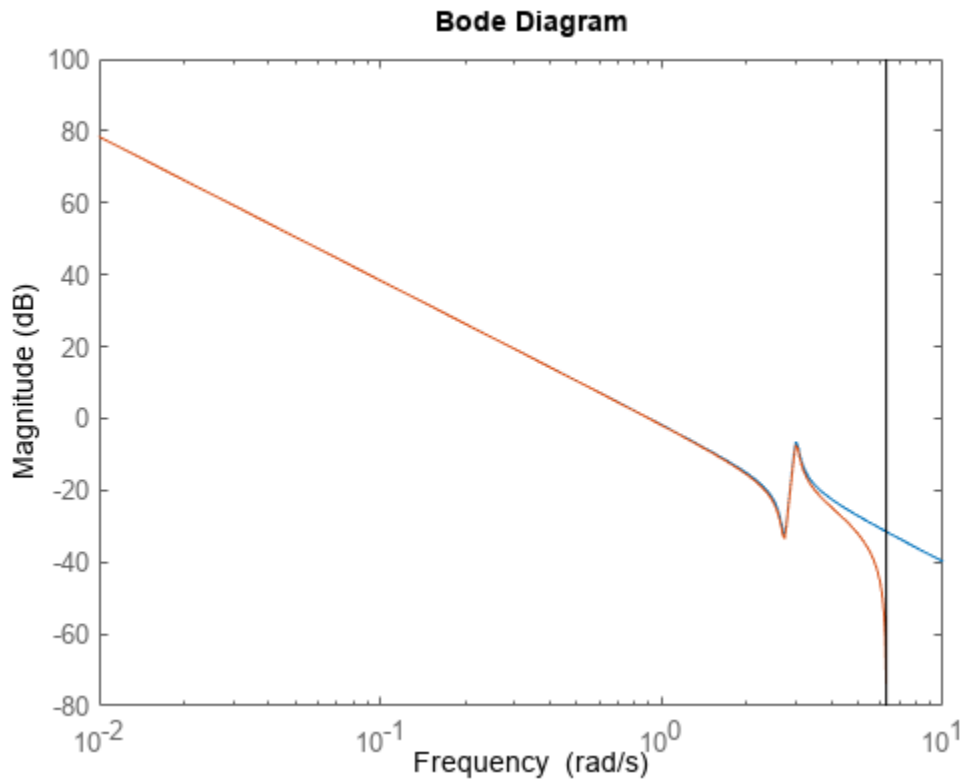

The Bode magnitude plot of a discrete-time system includes a vertical line marking the Nyquist frequency of the system.

Bode Magnitude Plot with Specified Line and Marker Attributes

Specify the color, linestyle, or marker for each system in a Bode magnitude plot using the LineSpec input arguments.

```
H = tf([1 0.1 7.5],[1 0.12 9 0 0]);  
Hd = c2d(H,0.5,'zoh');  
bodemag(H,'r',Hd,'b--')
```

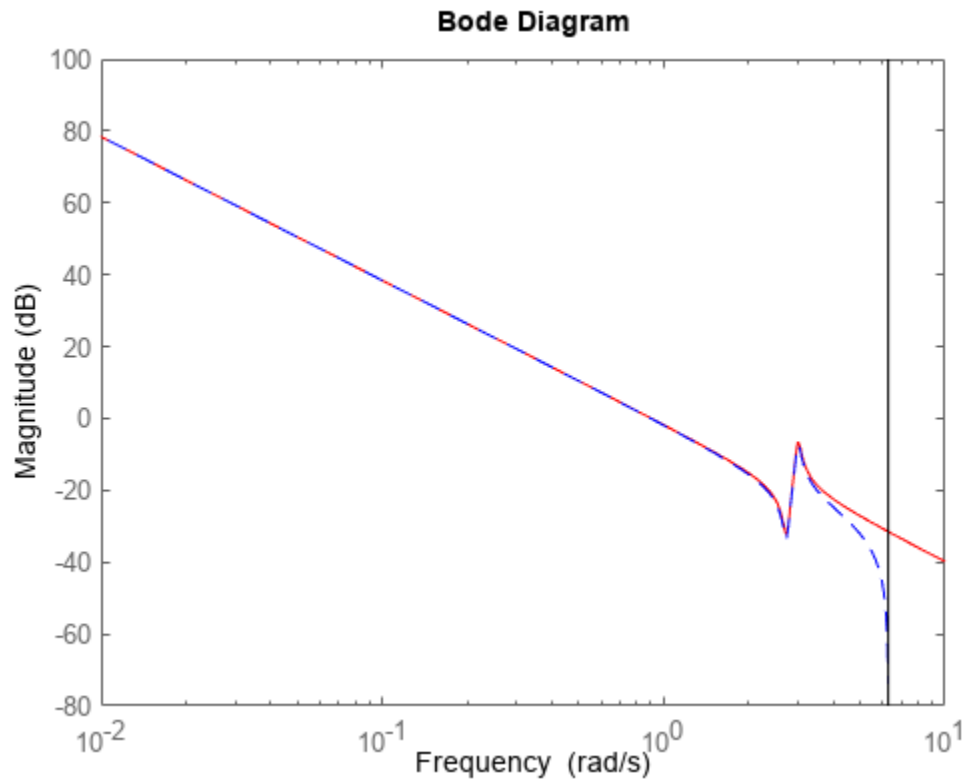

The first LineSpec argument 'r' specifies a solid red line for the response of H. The second LineSpec argument 'b--' specifies a dashed blue line for the response of Hd.

Magnitude of MIMO System

For this example, create a 2-output, 3-input system.

```
rng(0, 'twister'); % For reproducibility
H = rss(4,2,3);
```

For this system, bodemag plots the magnitude-only frequency responses of each I/O channel in a separate plot in a single figure.

```
bodemag(H)
```

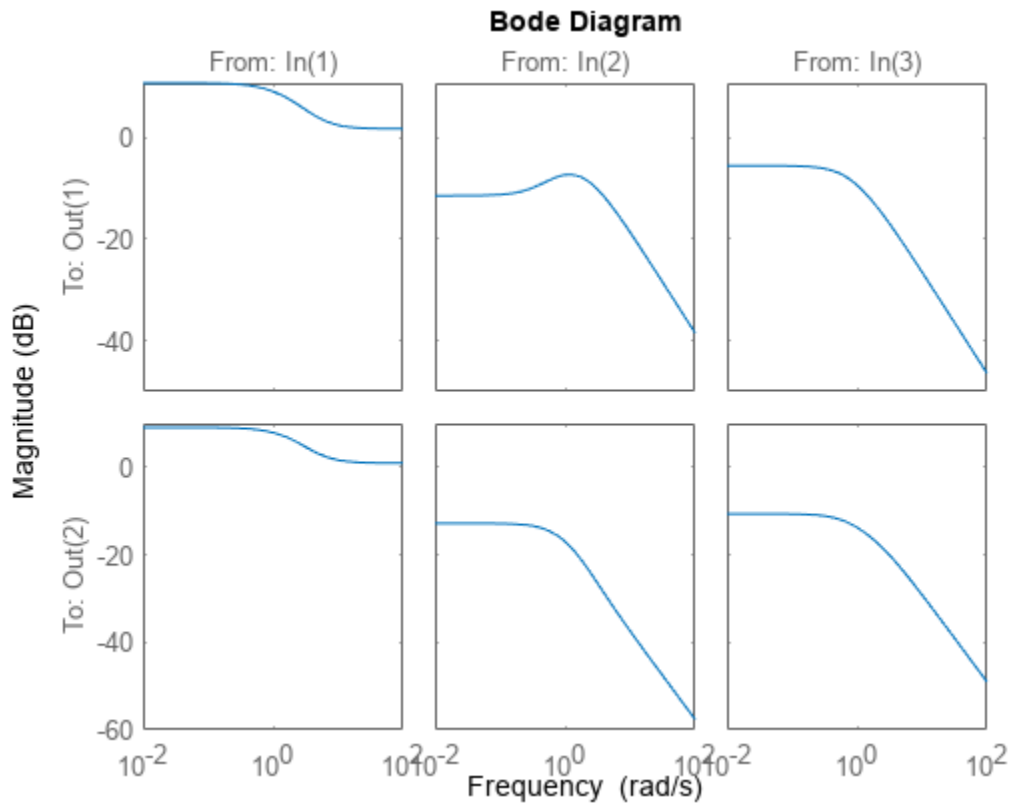

Input Arguments

sys — Dynamic system

dynamic system model | model array

Dynamic system, specified as a SISO or MIMO dynamic system model or array of dynamic system models. Dynamic systems that you can use include:

- Continuous-time or discrete-time numeric LTI models, such as `tf`, `zpk`, or `ss` models.
- Generalized or uncertain LTI models such as `genss` or `uss` models. (Using uncertain models requires Robust Control Toolbox software.)
 - For tunable control design blocks, the function evaluates the model at its current value for both plotting and returning frequency response data.
 - For uncertain control design blocks, the function plots the nominal value and random samples of the model. When you use output arguments, the function returns frequency response data for the nominal model only.
- Frequency-response data models such as `frd` models. For such models, the function plots the response at frequencies defined in the model.
- Identified LTI models, such as `idtf`, `idss`, or `idproc` models. (Using identified models requires System Identification Toolbox software.)

If `sys` is an array of models, the function plots the frequency responses of all models in the array on the same axes.

LineStyle — Line style, marker, and color

character vector | string

Line style, marker, and color, specified as a string or vector of one, two, or three characters. The characters can appear in any order. You do not need to specify all three characteristics (line style, marker, and color). For example, if you omit the line style and specify the marker, then the plot shows only the marker and no line. For more information about configuring this argument, see the `LineStyle` input argument of the `plot` function.

Example: `'r--'` specifies a red dashed line

Example: `'*b'` specifies blue asterisk markers

Example: `'y'` specifies a yellow line

w — Frequencies

{wmin,wmax} | vector

Frequencies at which to compute and plot frequency response, specified as the cell array `{wmin,wmax}` or as a vector of frequency values.

- If `w` is a cell array of the form `{wmin,wmax}`, then the function computes the index at frequencies ranging between `wmin` and `wmax`.
- If `w` is a vector of frequencies, then the function computes the index at each specified frequency. For example, use `logspace` to generate a row vector with logarithmically spaced frequency values.

Specify frequencies in units of `rad/TimeUnit`, where `TimeUnit` is the `TimeUnit` property of the model.

Algorithms

`bodemag` computes the frequency response as follows:

- 1 Compute the zero-pole-gain (`zpk`) representation of the dynamic system.
- 2 Evaluate the gain and phase of the frequency response based on the zero, pole, and gain data for each input/output channel of the system.
 - For continuous-time systems, `bodemag` evaluates the frequency response on the imaginary axis $s = j\omega$ and considers only positive frequencies.
 - For discrete-time systems, `bodemag` evaluates the frequency response on the unit circle. To facilitate interpretation, the command parameterizes the upper half of the unit circle as:

$$z = e^{j\omega T_s}, \quad 0 \leq \omega \leq \omega_N = \frac{\pi}{T_s},$$

where T_s is the sample time and ω_N is the Nyquist frequency. The equivalent continuous-time frequency ω is then used as the x -axis variable. Because $H(e^{j\omega T_s})$ is periodic with period $2\omega_N$, `bodemag` plots the response only up to the Nyquist frequency ω_N . If `sys` is a discrete-time model with unspecified sample time, `bodemag` uses $T_s = 1$.

Version History

Introduced in R2012a

See Also

bode | bodeplot | freqresp | nichols | nyquist | step

Topics

“Frequency-Domain Responses”

“Dynamic System Models”

bodeoptions

Create list of Bode plot options

Description

Use the `bodeoptions` command to create a `BodeOptions` object to customize Bode plot appearance. You can also use the command to override the plot preference settings in the MATLAB session in which you create the Bode plots.

Creation

Syntax

```
plotoptions = bodeoptions  
plotoptions = bodeoptions('cstprefs')
```

Description

`plotoptions = bodeoptions` returns a default set of plot options for use with the `bodeplot` command. You can use these options to customize the Bode plot appearance using the command line. This syntax is useful when you want to write a script to generate plots that look the same regardless of the preference settings of the MATLAB session in which you run the script.

`plotoptions = bodeoptions('cstprefs')` initializes the plot options with the options you selected in the Control System Toolbox and System Identification Toolbox Preferences Editor. For more information about the editor, see “Toolbox Preferences Editor”. This syntax is useful when you want to change a few plot options but otherwise use your default preferences. A script that uses this syntax may generate results that look different when run in a session with different preferences.

Properties

FreqUnits — Frequency units

'rad/s' (default)

Frequency units, specified as one of the following values:

- 'Hz'
- 'rad/second'
- 'rpm'
- 'kHz'
- 'MHz'
- 'GHz'
- 'rad/nanosecond'
- 'rad/microsecond'

- 'rad/millisecond'
- 'rad/minute'
- 'rad/hour'
- 'rad/day'
- 'rad/week'
- 'rad/month'
- 'rad/year'
- 'cycles/nanosecond'
- 'cycles/microsecond'
- 'cycles/millisecond'
- 'cycles/hour'
- 'cycles/day'
- 'cycles/week'
- 'cycles/month'
- 'cycles/year'

FreqScale — Frequency scale

'log' (default) | 'linear'

Frequency scale, specified as either 'log' or 'linear'.

MagUnits — Magnitude units

'dB' (default) | 'abs'

Magnitude units, specified as either 'dB' or absolute value 'abs'.

MagScale — Magnitude scale

'linear' (default) | 'log'

Magnitude scale, specified as either 'log' or 'linear'.

MagVisible — Toggle magnitude plot visibility

'on' (default) | 'off'

Toggle magnitude plot visibility, specified as either 'on' or 'off'.

MagLowerLimMode — Lower magnitude limit mode

'auto' (default) | 'manual'

Lower magnitude limit mode, specified as either 'auto' or 'manual'.

MagLowerLim — Lower magnitude limit value

'-inf' (default) | scalar

Lower magnitude limit value, specified as a scalar.

PhaseUnits — Phase units

'deg' (default) | 'rad'

Phase units, specified as either 'deg' or 'rad' to change to degrees or radians, respectively.

PhaseVisible — Toggle phase plot visibility

'on' (default) | 'off'

Toggle phase plot visibility, specified as either 'on' or 'off'.

PhaseWrapping — Enable phase wrapping

'off' (default) | 'on'

Enable phase wrapping, specified as either 'on' or 'off'. When you set PhaseWrapping to 'on', the plot wraps accumulated phase at the value specified by the PhaseWrappingBranch property.

PhaseWrappingBranch — Phase wrapping value

-180 (default) | integer

Phase wrapping value at which the plot wraps accumulated phase when PhaseWrapping is set to 'on'. By default, phase wraps into the interval $[-180^\circ, 180^\circ]$.

PhaseMatching — Enable phase matching

'off' (default) | 'on'

Enable phase matching, specified as either 'on' or 'off'. Turning PhaseMatching 'on' matches the phase to the value specified in PhaseMatchingValue at the frequency specified in PhaseMatchingFreq

PhaseMatchingFreq — Phase matching frequency

0 (default) | scalar

Phase matching frequency, specified as a scalar.

PhaseMatchingValue — Phase matching response value

0 (default) | scalar

Phase matching response value, specified as a scalar.

ConfidenceRegionNumberSD — Number of standard deviations to use to plot the confidence region

1 (default) | scalar

Number of standard deviations to use to plot the confidence region, specified as a scalar. This is applicable to identified models only.

IOMGrouping — Grouping of input-output pairs

'none' (default) | 'inputs' | 'outputs' | 'all'

Grouping of input-output (I/O) pairs, specified as one of the following:

- 'none' — No input-output grouping.
- 'inputs' — Group only the inputs.
- 'outputs' — Group only the outputs.
- 'all' — Group all the I/O pairs.

InputLabels — Input label style

structure (default)

Input label style, specified as a structure with the following fields:

- **FontSize** — Font size, specified as a scalar value greater than zero in point units. The default font size depends on the specific operating system and locale. One point equals 1/72 inch.
- **FontWeight** — Character thickness, specified as 'Normal' or 'bold'. MATLAB uses the **FontWeight** property to select a font from those available on your system. Not all fonts have a bold weight. Therefore, specifying a bold font weight can still result in the normal font weight.
- **FontAngle** — Character slant, specified as 'Normal' or 'italic'. Not all fonts have both font styles. Therefore, the italic font might look the same as the normal font.
- **Color** — Text color, specified as an RGB triplet. The default color is dark grey with the RGB triplet [0.4, 0.4, 0.4].
- **Interpreter** — Text interpreter, specified as one of these values:
 - 'tex' — Interpret characters using a subset of TeX markup. This is the default value of **Interpreter**.
 - 'latex' — Interpret characters using LaTeX markup.
 - 'none' — Display literal characters.

OutputLabels — Output label style

structure (default)

Output label style, specified as a structure with the following fields:

- **FontSize** — Font size, specified as a scalar value greater than zero in point units. The default font size depends on the specific operating system and locale. One point equals 1/72 inch.
- **FontWeight** — Character thickness, specified as 'Normal' or 'bold'. MATLAB uses the **FontWeight** property to select a font from those available on your system. Not all fonts have a bold weight. Therefore, specifying a bold font weight can still result in the normal font weight.
- **FontAngle** — Character slant, specified as 'Normal' or 'italic'. Not all fonts have both font styles. Therefore, the italic font might look the same as the normal font.
- **Color** — Text color, specified as an RGB triplet. The default color is dark grey with the RGB triplet [0.4, 0.4, 0.4].
- **Interpreter** — Text interpreter, specified as one of these values:
 - 'tex' — Interpret characters using a subset of TeX markup. This is the default value of **Interpreter**.
 - 'latex' — Interpret characters using LaTeX markup.
 - 'none' — Display literal characters.

InputVisible — Toggle display of inputs

{ 'on' } (default) | { 'off' } | cell array

Toggle display of inputs, specified as either { 'on' }, { 'off' } or a cell array with multiple elements .

OutputVisible — Toggle display of outputs

{ 'on' } (default) | { 'off' } | cell array

Toggle display of outputs, specified as either { 'on' }, { 'off' } or a cell array with multiple elements.

Title — Title text and style

structure (default)

Title text and style, specified as a structure with the following fields:

- `String` — Label text, specified as a character vector. By default, the plot is titled 'Bode Diagram'.
- `FontSize` — Font size, specified as a scalar value greater than zero in point units. The default font size depends on the specific operating system and locale. One point equals 1/72 inch.
- `FontWeight` — Character thickness, specified as 'Normal' or 'bold'. MATLAB uses the `FontWeight` property to select a font from those available on your system. Not all fonts have a bold weight. Therefore, specifying a bold font weight can still result in the normal font weight.
- `FontAngle` — Character slant, specified as 'Normal' or 'italic'. Not all fonts have both font styles. Therefore, the italic font might look the same as the normal font.
- `Color` — Text color, specified as an RGB triplet. The default color is black specified by the RGB triplet `[0,0,0]`.
- `Interpreter` — Text interpreter, specified as one of these values:
 - 'tex' — Interpret characters using a subset of TeX markup. This is the default value of `Interpreter`.
 - 'latex' — Interpret characters using LaTeX markup.
 - 'none' — Display literal characters.

XLabel — X-axis label text and style

structure (default)

X-axis label text and style, specified as a structure with the following fields:

- `String` — Label text, specified as a character vector. By default, the axis is titled based on the frequency units `FreqUnits`.
- `FontSize` — Font size, specified as a scalar value greater than zero in point units. The default font size depends on the specific operating system and locale. One point equals 1/72 inch.
- `FontWeight` — Character thickness, specified as 'Normal' or 'bold'. MATLAB uses the `FontWeight` property to select a font from those available on your system. Not all fonts have a bold weight. Therefore, specifying a bold font weight can still result in the normal font weight.
- `FontAngle` — Character slant, specified as 'Normal' or 'italic'. Not all fonts have both font styles. Therefore, the italic font might look the same as the normal font.
- `Color` — Text color, specified as an RGB triplet. The default color is black specified by the RGB triplet `[0,0,0]`.
- `Interpreter` — Text interpreter, specified as one of these values:
 - 'tex' — Interpret characters using a subset of TeX markup. This is the default value of `Interpreter`.
 - 'latex' — Interpret characters using LaTeX markup.
 - 'none' — Display literal characters.

YLabel — Y-axis label text and style

structure (default)

Y-axis label text and style, specified as a structure with the following fields:

- `String` — Label text, specified as a cell array of character vectors. By default, the axis label is a 1x2 cell array with 'Magnitude' and 'Phase'.

- **FontSize** — Font size, specified as a scalar value greater than zero in point units. The default font size depends on the specific operating system and locale. One point equals 1/72 inch.
- **FontWeight** — Character thickness, specified as 'Normal' or 'bold'. MATLAB uses the **FontWeight** property to select a font from those available on your system. Not all fonts have a bold weight. Therefore, specifying a bold font weight can still result in the normal font weight.
- **FontAngle** — Character slant, specified as 'Normal' or 'italic'. Not all fonts have both font styles. Therefore, the italic font might look the same as the normal font.
- **Color** — Text color, specified as an RGB triplet. The default color is black specified by the RGB triplet [0,0,0].
- **Interpreter** — Text interpreter, specified as one of these values:
 - 'tex' — Interpret characters using a subset of TeX markup. This is the default value of **Interpreter**.
 - 'latex' — Interpret characters using LaTeX markup.
 - 'none' — Display literal characters.

TickLabel — Tick label style

structure (default)

Tick label style, specified as a structure with the following fields:

- **FontSize** — Font size, specified as a scalar value greater than zero in point units. The default font size depends on the specific operating system and locale. One point equals 1/72 inch.
- **FontWeight** — Character thickness, specified as 'Normal' or 'bold'. MATLAB uses the **FontWeight** property to select a font from those available on your system. Not all fonts have a bold weight. Therefore, specifying a bold font weight can still result in the normal font weight.
- **FontAngle** — Character slant, specified as 'Normal' or 'italic'. Not all fonts have both font styles. Therefore, the italic font might look the same as the normal font.
- **Color** — Text color, specified as an RGB triplet. The default color is black specified by the RGB triplet [0,0,0].

Grid — Toggle grid display

'off' (default) | 'on'

Toggle grid display on the plot, specified as either 'off' or 'on'.

GridColor — Color of the grid lines

[0.15,0.15,0.15] (default) | RGB triplet

Color of the grid lines, specified as an RGB triplet. The default color is light grey specified by the RGB triplet [0.15,0.15,0.15].

XLimMode — X-axis limit selection mode

'auto' (default) | 'manual' | cell array

Selection mode for the x-axis limits, specified as one of these values:

- 'auto' — Enable automatic limit selection, which is based on the total span of the plotted data.
- 'manual' — Manually specify the axis limits. To specify the axis limits, set the **XLim** property.

YLimMode — Y-axis limit selection mode

'auto' (default) | 'manual' | cell array

Selection mode for the y-axis limits, specified as one of these values:

- 'auto' — Enable automatic limit selection, which is based on the total span of the plotted data.
- 'manual' — Manually specify the axis limits. To specify the axis limits, set the YLim property.

XLim — X-axis limits

'{[1,10]}' (default) | cell array of two-element vector of the form [min,max] | cell array

X-axis limits, specified as a cell array of two-element vector of the form [min,max].

YLim — Y-axis limits

'{[1,10]}' (default) | cell array of two-element vector of the form [min,max] | cell array

Y-axis limits, specified as a cell array of two-element vector of the form [min,max].

Object Functions

bode	Bode plot of frequency response, or magnitude and phase data
bodeplot	Plot Bode frequency response with additional plot customization options
getoptions	Return plot options handle or plot options property
setoptions	Set plot options handle or plot options property

Examples

Custom Bode Plot Settings Independent of Preferences

For this example, create a Bode plot that uses 15-point red text for the title. This plot should look the same, regardless of the preferences of the MATLAB session in which it is generated.

First, create a default options set using `bodeoptions`.

```
opts = bodeoptions;
```

Next, change the required properties of the options set `opts`.

```
opts.Title.FontSize = 15;
opts.Title.Color = [1 0 0];
opts.FreqUnits = 'Hz';
```

Now, create a Bode plot using the options set `opts`.

```
bodeplot(tf(1,[1,1]),opts);
```

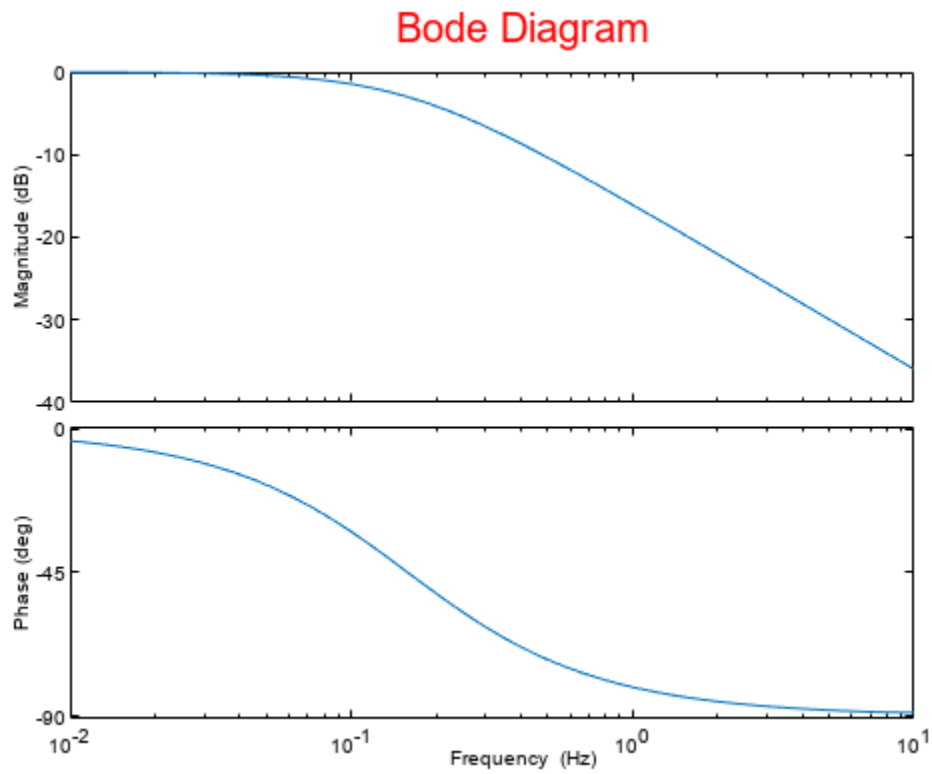

Because `opts` begins with a fixed set of options, the plot result is independent of the toolbox preferences of the MATLAB session.

Create Bode Plot with Custom Settings

Create a Bode plot that suppresses the phase plot and uses frequency units Hz instead of the default radians/second. Otherwise, the plot uses the settings that are saved in the toolbox preferences.

First, create an options set based on the toolbox preferences.

```
opts = bodeoptions('cstprefs');
```

Change properties of the options set.

```
opts.PhaseVisible = 'off';  
opts.FreqUnits = 'Hz';
```

Create a plot using the options.

```
h = bodeplot(tf(1,[1,1]),opts);
```

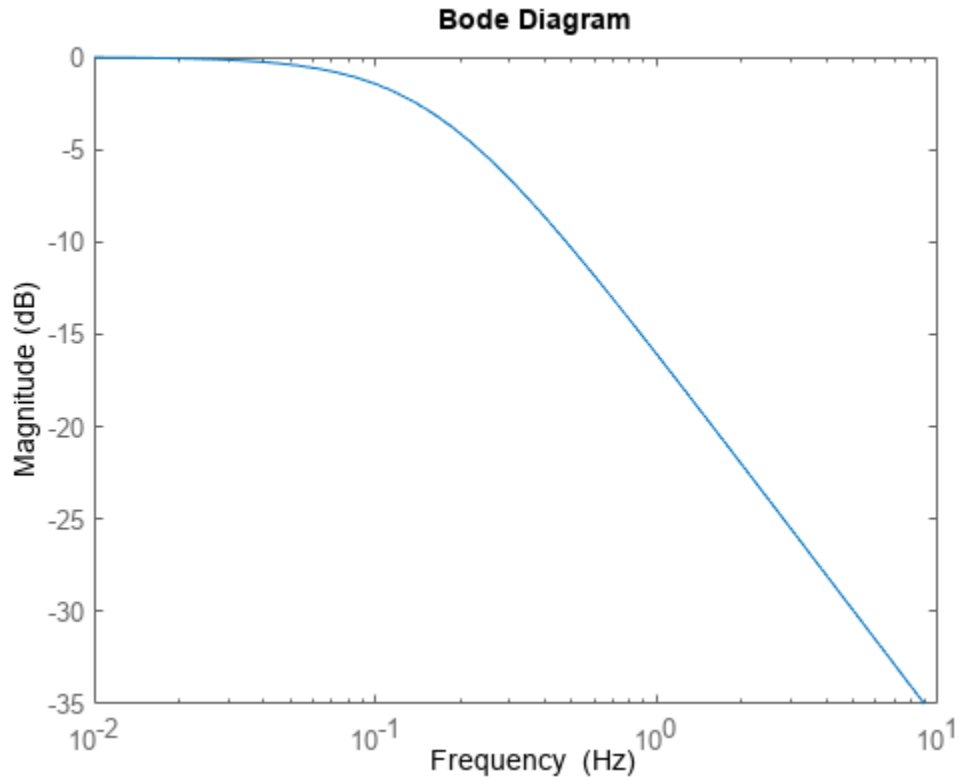

Depending on your own toolbox preferences, the plot you obtain might look different from this plot. Only the properties that you set explicitly, in this example `PhaseVisible` and `FreqUnits`, override the toolbox preferences.

Version History

Introduced in R2008a

See Also

`bode` | `bodeplot` | `getoptions` | `setoptions`

Topics

“Toolbox Preferences Editor”

bodeplot

Plot Bode frequency response with additional plot customization options

Syntax

```
h = bodeplot(sys)
h = bodeplot(sys1,sys2,...,sysN)
h = bodeplot(sys1,LineStyle1,...,sysN,LineStyleN)
h = bodeplot(AX, ___)
h = bodeplot( ___, plotoptions)
h = bodeplot( ___, w)
```

Description

`bodeplot` lets you plot the Bode magnitude and phase of a dynamic system model with a broader range of plot customization options than `bode`. You can use `bodeplot` to obtain the plot handle and use it to customize the plot, such as modify the axes labels, limits and units. You can also use `bodeplot` to draw a Bode response plot on an existing set of axes represented by an axes handle. To customize an existing Bode plot using the plot handle:

- 1 Obtain the plot handle
- 2 Use `getoptions` to obtain the option set
- 3 Update the plot using `setoptions` to modify the required options

For more information, see “Customizing Response Plots from the Command Line”. To create Bode plots with default options or to extract the frequency response data, use `bode`.

`h = bodeplot(sys)` plots the Bode magnitude and phase of the dynamic system model `sys` and returns the plot handle `h` to the plot. You can use this handle `h` to customize the plot with the `getoptions` and `setoptions` commands. If `sys` is a multi-input, multi-output (MIMO) model, then `bodeplot` produces a grid of Bode plots, each plot displaying the frequency response of one I/O pair.

`h = bodeplot(sys1,sys2,...,sysN)` plots the frequency response of multiple dynamic systems `sys1,sys2,...,sysN` on the same plot. All systems must have the same number of inputs and outputs to use this syntax.

`h = bodeplot(sys1,LineStyle1,...,sysN,LineStyleN)` sets the line style, marker type, and color for the Bode response of each system. All systems must have the same number of inputs and outputs to use this syntax.

`h = bodeplot(AX, ___)` plots the Bode response on the `AX` or `UIAxes` object in the current figure with the handle `AX`. Use this syntax when creating apps using `bodeplot` in the App Designer.

`h = bodeplot(___, plotoptions)` plots the Bode frequency response with the options set specified in `plotoptions`. You can use these options to customize the Bode plot appearance using the command line. Settings you specify in `plotoptions` overrides the preference settings in the MATLAB session in which you run `bodeplot`. Therefore, this syntax is useful when you want to write a script to generate multiple plots that look the same regardless of the local preferences.

`h = bodeplot(___, w)` plots system responses for frequencies specified by the frequencies in `w`.

- If `w` is a cell array of the form `{wmin,wmax}`, then `bodeplot` plots the response at frequencies ranging between `wmin` and `wmax`.
- If `w` is a vector of frequencies, then `bodeplot` plots the response at each specified frequency.

You can use `w` with any of the input-argument combinations in previous syntaxes.

See `logspace` to generate logarithmically spaced frequency vectors.

Examples

Customize Bode Plot using Plot Handle

For this example, use the plot handle to change the frequency units to Hz and turn off the phase plot.

Generate a random state-space model with 5 states and create the Bode plot with plot handle `h`.

```
rng("default")
sys = rss(5);
h = bodeplot(sys);
```

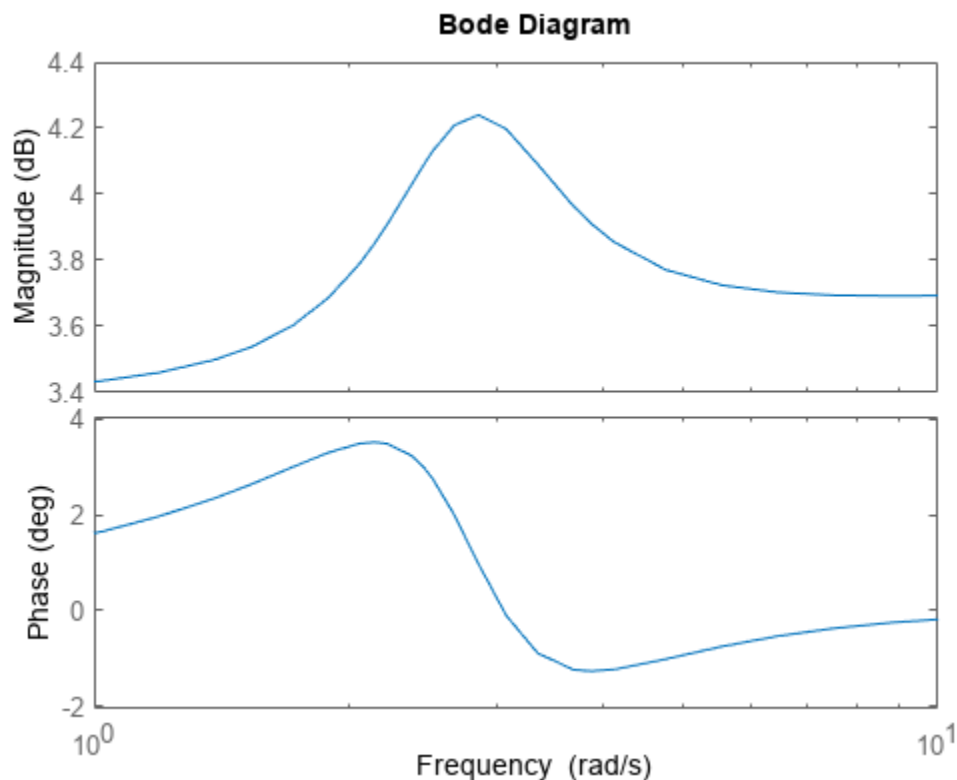

Change the units to Hz and suppress the phase plot. To do so, edit properties of the plot handle, `h` using `setoptions`.

```
setoptions(h, 'FreqUnits', 'Hz', 'PhaseVisible', 'off');
```

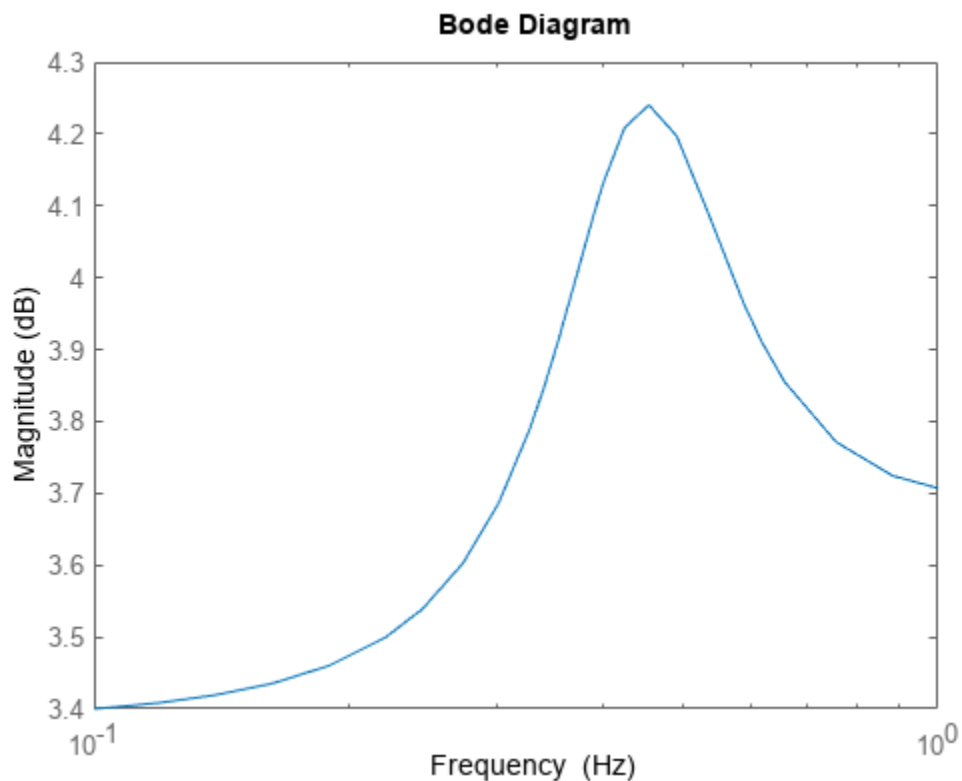

The Bode plot automatically updates when you call `setoptions`.

Alternatively, you can also use the `bodeoptions` command to specify the required plot options. First, create an options set based on the toolbox preferences.

```
p = bodeoptions('cstprefs');
```

Change properties of the options set by setting the frequency units to Hz and hide the phase plot.

```
p.FreqUnits = 'Hz';  
p.PhaseVisible = 'off';  
bodeplot(sys,p);
```

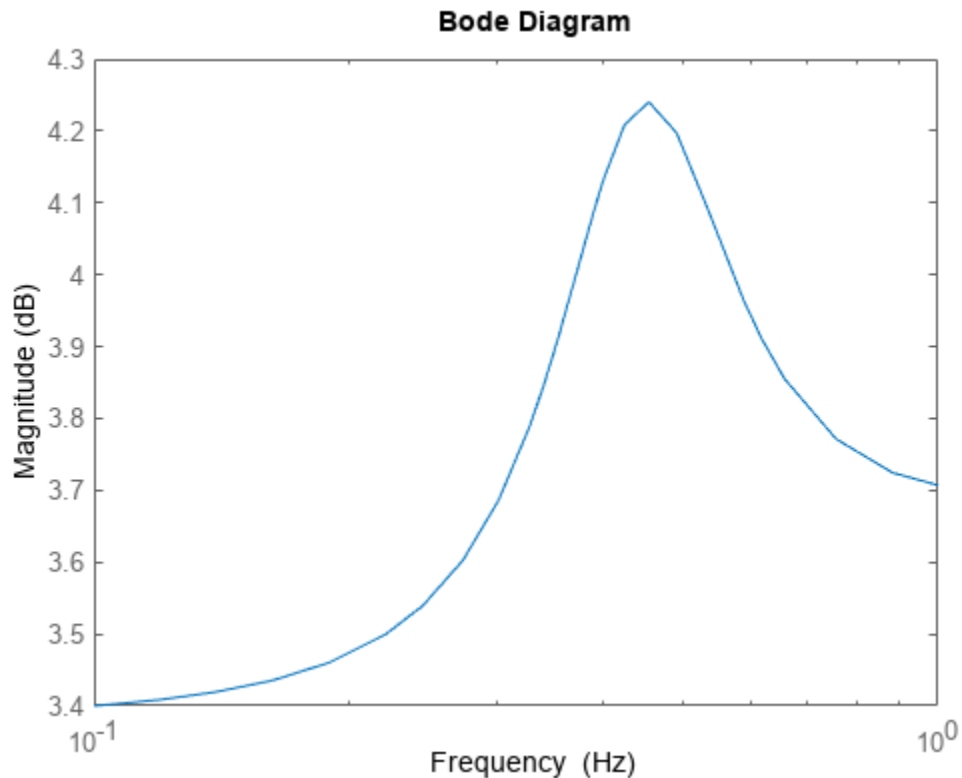

You can use the same option set to create multiple Bode plots with the same customization. Depending on your own toolbox preferences, the plot you obtain might look different from this plot. Only the properties that you set explicitly, in this example `PhaseVisible` and `FreqUnits`, override the toolbox preferences.

Custom Bode Plot Settings Independent of Preferences

For this example, create a Bode plot that uses 15-point red text for the title. This plot should look the same, regardless of the preferences of the MATLAB session in which it is generated.

First, create a default options set using `bodeoptions`.

```
opts = bodeoptions;
```

Next, change the required properties of the options set `opts`.

```
opts.Title.FontSize = 15;
opts.Title.Color = [1 0 0];
opts.FreqUnits = 'Hz';
```

Now, create a Bode plot using the options set `opts`.

```
bodeplot(tf(1,[1,1]),opts);
```

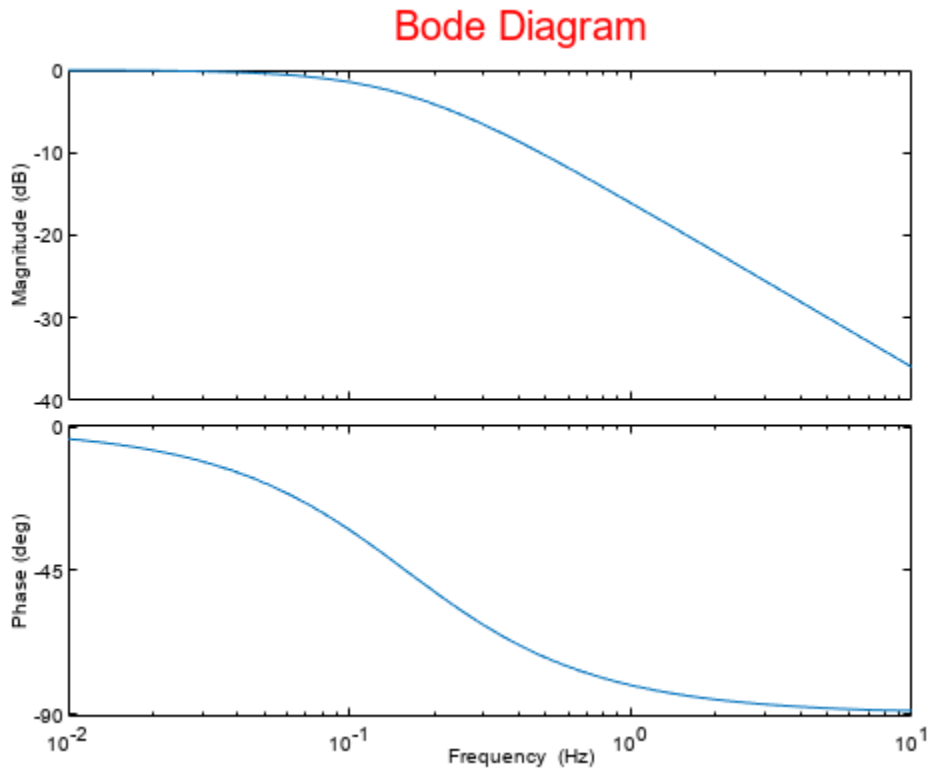

Because `opts` begins with a fixed set of options, the plot result is independent of the toolbox preferences of the MATLAB session.

Customized Bode Plot of Transfer Function

For this example, create a Bode plot of the following continuous-time SISO dynamic system. Then, turn the grid on, rename the plot and change the frequency scale.

$$\text{sys}(s) = \frac{s^2 + 0.1s + 7.5}{s^4 + 0.12s^3 + 9s^2}$$

Create the transfer function `sys`.

```
sys = tf([1 0.1 7.5],[1 0.12 9 0 0]);
```

Next, create the options set using `bodeoptions` and change the required plot properties.

```
plotoptions = bodeoptions;
plotoptions.Grid = 'on';
plotoptions.FreqScale = 'linear';
plotoptions.Title.String = 'Bode Plot of Transfer Function';
```

Now, create the Bode plot with the custom option set `plotoptions`.

```
bodeplot(sys,plotoptions)
```

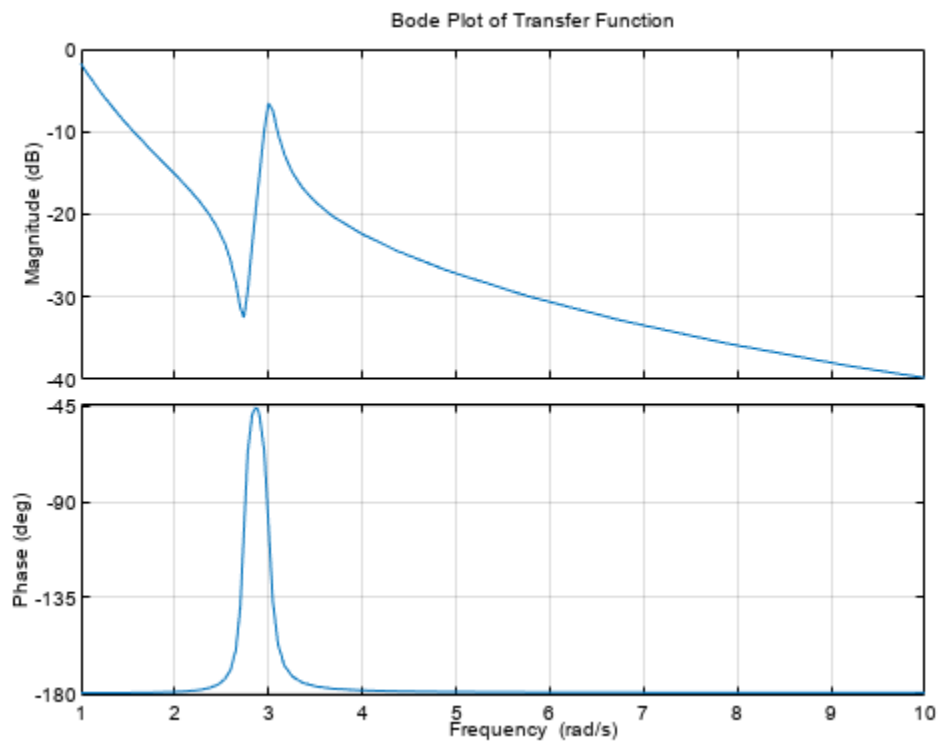

`bodeplot` automatically selects the plot range based on the system dynamics.

Bode Plot with Specified Frequency Scale and Units

For this example, consider a MIMO state-space model with 3 inputs, 3 outputs and 3 states. Create a Bode plot with linear frequency scale, specify frequency units in Hz and turn the grid on.

Create the MIMO state-space model `sys_mimo`.

```
J = [8 -3 -3; -3 8 -3; -3 -3 8];
F = 0.2*eye(3);
A = -J\F;
B = inv(J);
C = eye(3);
D = 0;
sys_mimo = ss(A,B,C,D);
size(sys_mimo)
```

State-space model with 3 outputs, 3 inputs, and 3 states.

Create a Bode plot with plot handle `h` and use `getoptions` for a list of the options available.

```
h = bodeplot(sys_mimo);
p = getoptions(h)
```

p =

```
    FreqUnits: 'rad/s'
    FreqScale: 'log'
    MagUnits: 'dB'
    MagScale: 'linear'
    MagVisible: 'on'
    MagLowerLimMode: 'auto'
    PhaseUnits: 'deg'
    PhaseVisible: 'on'
    PhaseWrapping: 'off'
    PhaseMatching: 'off'
    PhaseMatchingFreq: 0
    ConfidenceRegionNumberSD: 1
    MagLowerLim: 0
    PhaseMatchingValue: 0
    PhaseWrappingBranch: -180
    IOGrouping: 'none'
    InputLabels: [1x1 struct]
    OutputLabels: [1x1 struct]
    InputVisible: {3x1 cell}
    OutputVisible: {3x1 cell}
    Title: [1x1 struct]
    XLabel: [1x1 struct]
    YLabel: [1x1 struct]
    TickLabel: [1x1 struct]
    Grid: 'off'
    GridColor: [0.1500 0.1500 0.1500]
    XLim: {3x1 cell}
    YLim: {6x1 cell}
    XLimMode: {3x1 cell}
    YLimMode: {6x1 cell}
```

Use `setoptions` to update the plot with the requires customization.

```
setoptions(h, 'FreqScale', 'linear', 'FreqUnits', 'Hz', 'Grid', 'on');
```

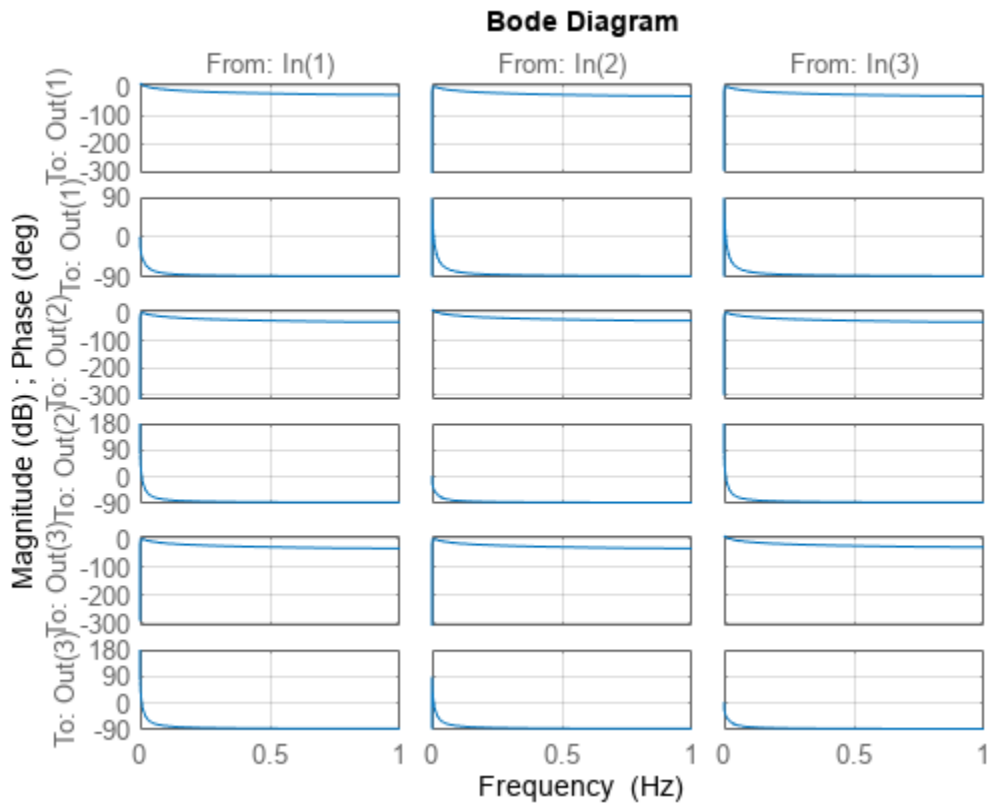

The Bode plot automatically updates when you call `setoptions`. For MIMO models, `bodeplot` produces an array of Bode plots, each plot displaying the frequency response of one I/O pair.

Match Phase at Specified Frequency

For this example, match the phase of your system response such that the phase at 1 rad/sec is 150 degrees.

First, create a Bode plot of transfer function system with plot handle `h`.

```
sys = tf(1,[1 1]);
h = bodeplot(sys);
```

Use `getoptions` to obtain the plot properties. Change the properties `PhaseMatchingFreq` and `PhaseMatchingValue` to match a phase to a specified frequency.

```
p = getoptions(h);
p.PhaseMatching = 'on';
p.PhaseMatchingFreq = 1;
p.PhaseMatchingValue = 150;
```

Update the plot using `setoptions`.

```
setoptions(h,p);
```

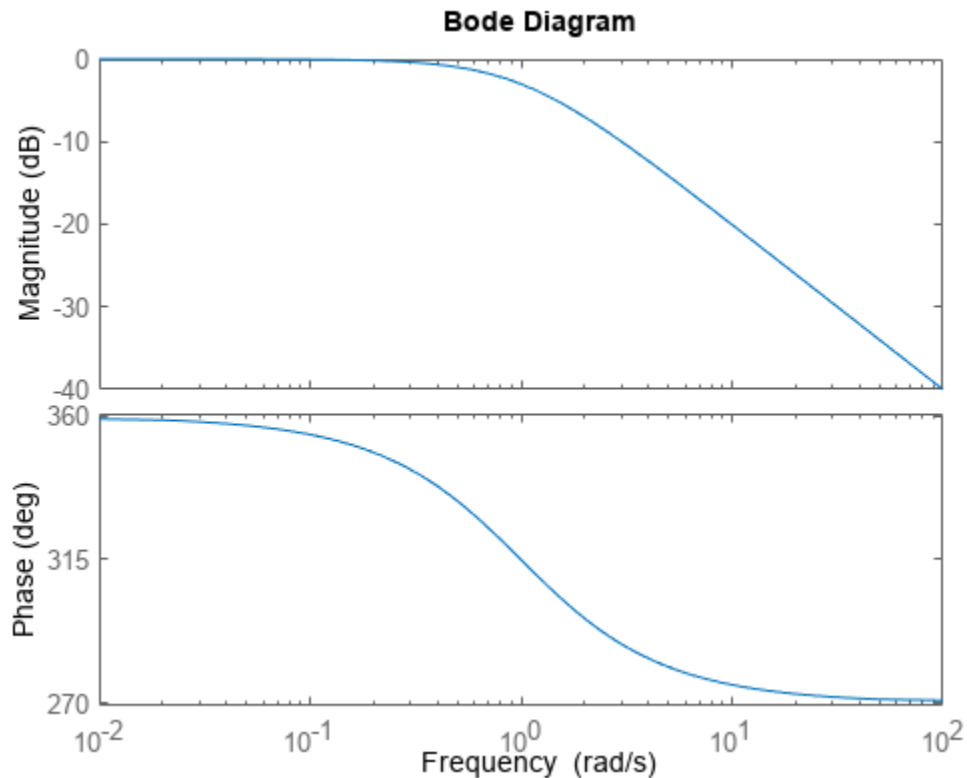

The first bode plot has a phase of -45 degrees at a frequency of 1 rad/s. Setting the phase matching options so that at 1 rad/s the phase is near 150 degrees yields the second Bode plot. Note that, however, the phase can only be $-45 + N \cdot 360$, where N is an integer. So the plot is set to the nearest allowable phase, namely 315 degrees (or $1 \cdot 360 - 45 = 315^\circ$).

Display Confidence Regions of Identified Models

For this example, compare the frequency responses of two identified state-space models with 2 and 6 states along with their 2σ confidence regions.

Load the identified state-space model data and estimate the two models using `n4sid`. Using `n4sid` requires a System Identification Toolbox license.

```
load iddata1
sys1 = n4sid(z1,2);
sys2 = n4sid(z1,6);
```

Create a Bode plot of the two systems.

```
bodeplot(sys1, 'r', sys2, 'b');
legend('sys1', 'sys2');
```

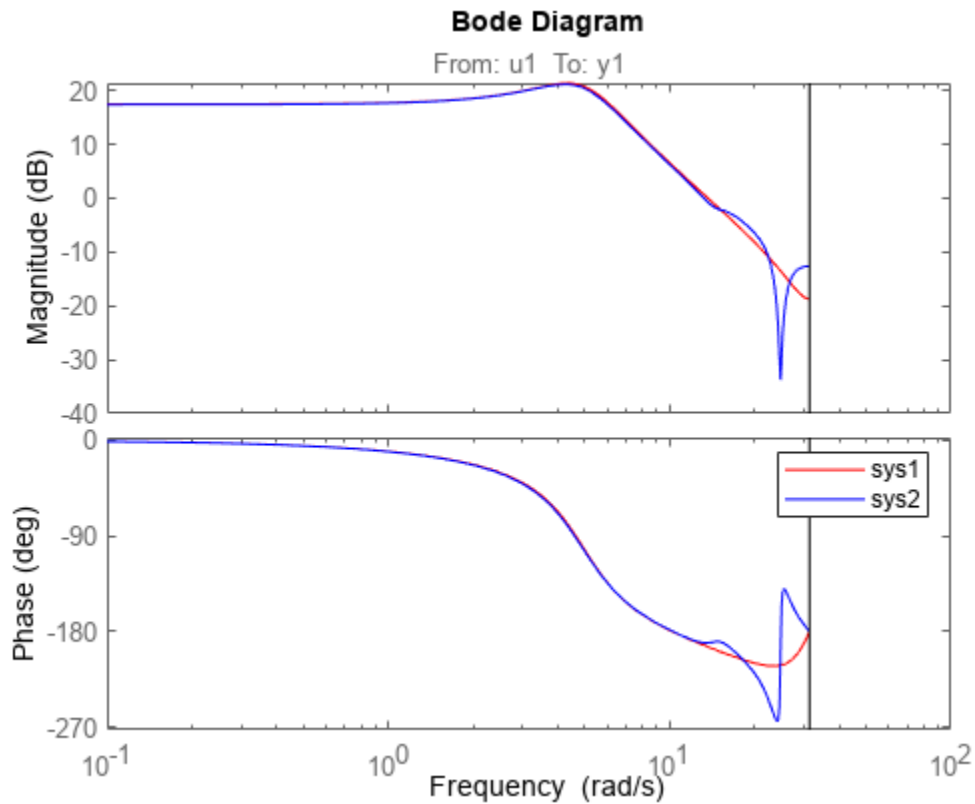



From the plot, observe that both models produce about 70% fit to data. However, `sys2` shows higher uncertainty in its frequency response, especially close to the Nyquist frequency. Now, use `linspace` to create a vector of frequencies and plot the Bode response using the frequency vector `w`.

```
w = linspace(8,10*pi,256);
h = bodeplot(sys1,sys2,w);
legend('sys1','sys2');
```

Use `setoptions` to turn on phase matching and to specify the standard deviation of the confidence region.

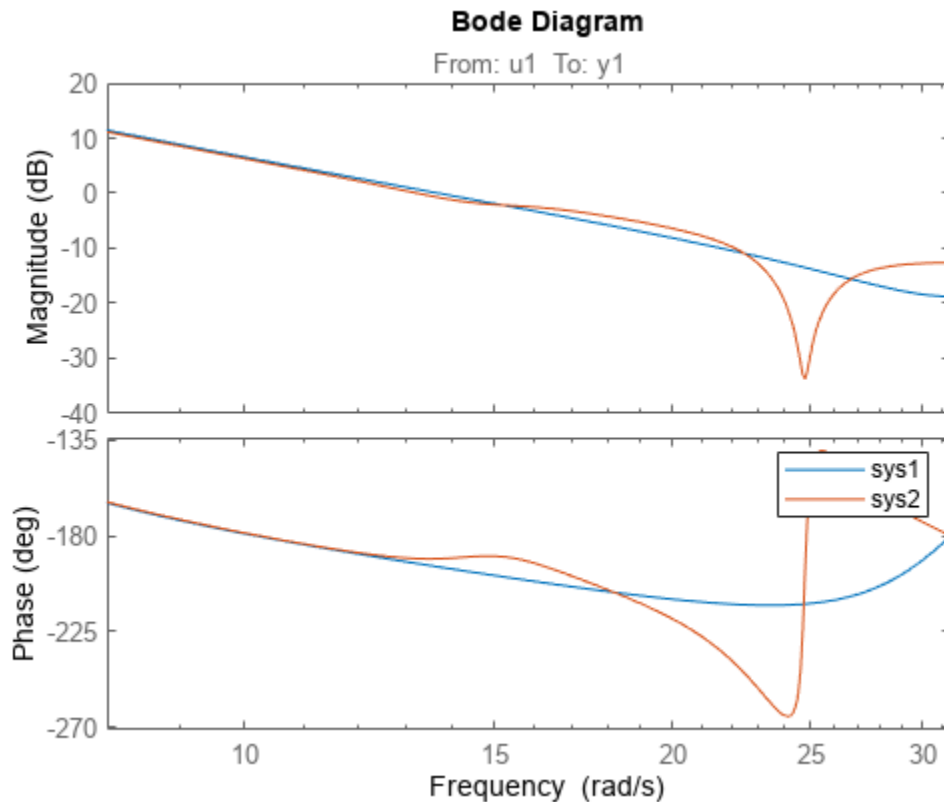
```
setoptions(h,'PhaseMatching','on','ConfidenceRegionNumberSD',2);
```



You can use the `showconfidence` command to display the confidence regions on the Bode plot.

```
showConfidence(h)
```

Frequency Response of Identified Parametric and Nonparametric Models

For this example, compare the frequency response of a parametric model, identified from input/output data, to a non-parametric model identified using the same data. Identify parametric and non-parametric models based on the data.

Load the data and create the parametric and non-parametric models using `tfest` and `spa`, respectively.

```
load iddata2 z2;
w = linspace(0,10*pi,128);
sys_np = spa(z2,[],w);
sys_p = tfest(z2,2);
```

`spa` and `tfest` require System Identification Toolbox™ software. The model `sys_np` is a non-parametric identified model while, `sys_p` is a parametric identified model.

Create an options set to turn phase matching and the grid on. Then, create a Bode plot that includes both systems using this options set.

```

plotoptions = bodeoptions;
plotoptions.PhaseMatching = 'on';
plotoptions.Grid = 'on';
bodeplot(sys_p,sys_np,w,plotoptions);
legend('Parametric Model','Non-Parametric model');

```

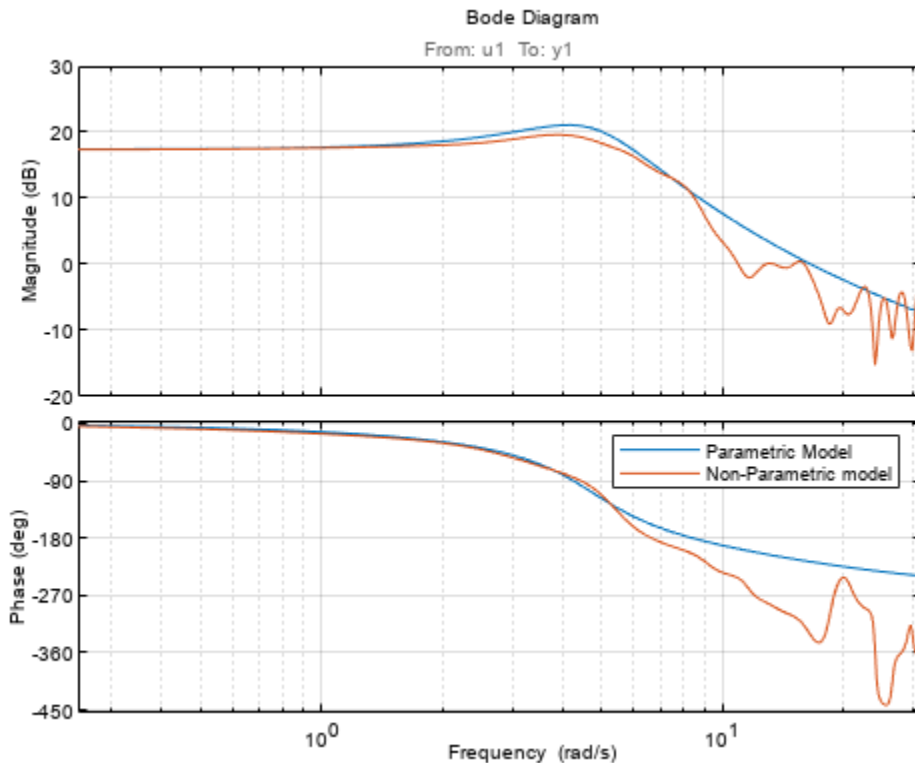

Input Arguments

sys — Dynamic system

dynamic system model | model array

Dynamic system, specified as a SISO or MIMO dynamic system model or array of dynamic system models. Dynamic systems that you can use include:

- Continuous-time or discrete-time numeric LTI models, such as `tf`, `zpk`, or `ss` models.
- Sparse state-space models, such as `sparss` or `mechss` models. Frequency grid `w` must be specified for sparse models.
- Generalized or uncertain LTI models such as `genss` or `uss` models. (Using uncertain models requires Robust Control Toolbox software.)
 - For tunable control design blocks, the function evaluates the model at its current value to plot the frequency response data.
 - For uncertain control design blocks, the function plots the nominal value and random samples of the model.

- Frequency-response data models such as `frd` models. For such models, the function plots the response at frequencies defined in the model.
- Identified LTI models, such as `idtf`, `idss`, or `idproc` models. For such models, the function can also plot confidence intervals and return standard deviations of the frequency response. See “Bode Plot of Identified Model” on page 2-68. (Using identified models requires System Identification Toolbox software.)

If `sys` is an array of models, the function plots the frequency responses of all models in the array on the same axes.

LineStyle — Line style, marker, and color

character vector | string

Line style, marker, and color, specified as a character vector or string containing symbols. The symbols can appear in any order. You do not need to specify all three characteristics (line style, marker, and color). For example, if you omit the line style and specify the marker, then the plot shows only the marker and no line.

Example: `'--or'` is a red dashed line with circle markers

Line Style	Description
-	Solid line
--	Dashed line
:	Dotted line
-.	Dash-dot line

Marker	Description
'o'	Circle
'+'	Plus sign
'*'	Asterisk
'.'	Point
'x'	Cross
'_'	Horizontal line
' '	Vertical line
's'	Square
'd'	Diamond
'^'	Upward-pointing triangle
'v'	Downward-pointing triangle
'>'	Right-pointing triangle
'<'	Left-pointing triangle
'p'	Pentagram
'h'	Hexagram

Color	Description
y	yellow
m	magenta
c	cyan
r	red
g	green
b	blue
w	white
k	black

AX — Target axes

Axes object | UIAxes object

Target axes, specified as an Axes or UIAxes object. If you do not specify the axes and if the current axes are Cartesian axes, then `bodeplot` plots on the current axes. Use AX to plot into specific axes when creating apps in the App Designer.

plotoptions — Bode plot options set

BodePlotOptions object

Bode plot options set, specified as a BodePlotOptions object. You can use this option set to customize the Bode plot appearance. Use `bodeoptions` to create the option set. Settings you specify in `plotoptions` overrides the preference settings in the MATLAB session in which you run `bodeplot`. Therefore, `plotoptions` is useful when you want to write a script to generate multiple plots that look the same regardless of the local preferences.

For the list of available options, see `bodeoptions`.

w — Frequencies

{wmin,wmax} | vector

Frequencies at which to compute and plot frequency response, specified as the cell array {wmin,wmax} or as a vector of frequency values.

- If `w` is a cell array of the form {wmin,wmax}, then the function computes the response at frequencies ranging between `wmin` and `wmax`.
- If `w` is a vector of frequencies, then the function computes the response at each specified frequency. For example, use `logspace` to generate a row vector with logarithmically spaced frequency values.

Specify frequencies in units of rad/TimeUnit, where TimeUnit is the TimeUnit property of the model.

Output Arguments

h — Plot handle

handle object

Plot handle, returned as a `handle` object. Use the handle `h` to get and set the properties of the Bode plot using `getoptions` and `setoptions`. For the list of available options, see the *Properties and Values Reference* section in “Customizing Response Plots from the Command Line”.

Version History

Introduced before R2006a

See Also

`bode` | `bodeoptions` | `getoptions` | `setoptions`

Topics

“Customizing Response Plots from the Command Line”

c2d

Convert model from continuous to discrete time

Syntax

```
sysd = c2d(sysc,Ts)
sysd = c2d(sysc,Ts,method)
sysd = c2d(sysc,Ts,opts)
[sysd,G] = c2d( ___ )
```

Description

`sysd = c2d(sysc,Ts)` discretizes the continuous-time dynamic system model `sysc` using zero-order hold on the inputs and a sample time of `Ts`.

`sysd = c2d(sysc,Ts,method)` specifies the discretization method.

`sysd = c2d(sysc,Ts,opts)` specifies additional options for the discretization.

`[sysd,G] = c2d(___)`, where `sysc` is a state-space model, returns a matrix, `G` that maps the continuous initial conditions x_0 and u_0 of the state-space model to the discrete-time initial state vector `x[0]`.

Examples

Discretize a Transfer Function

Discretize the following continuous-time transfer function:

$$H(s) = e^{-0.3s} \frac{s - 1}{s^2 + 4s + 5}$$

This system has an input delay of 0.3 s. Discretize the system using the triangle (first-order-hold) approximation with sample time `Ts = 0.1` s.

```
H = tf([1 -1],[1 4 5], 'InputDelay', 0.3);
Hd = c2d(H,0.1, 'foh');
```

Compare the step responses of the continuous-time and discretized systems.

```
step(H, '-', Hd, '--')
```

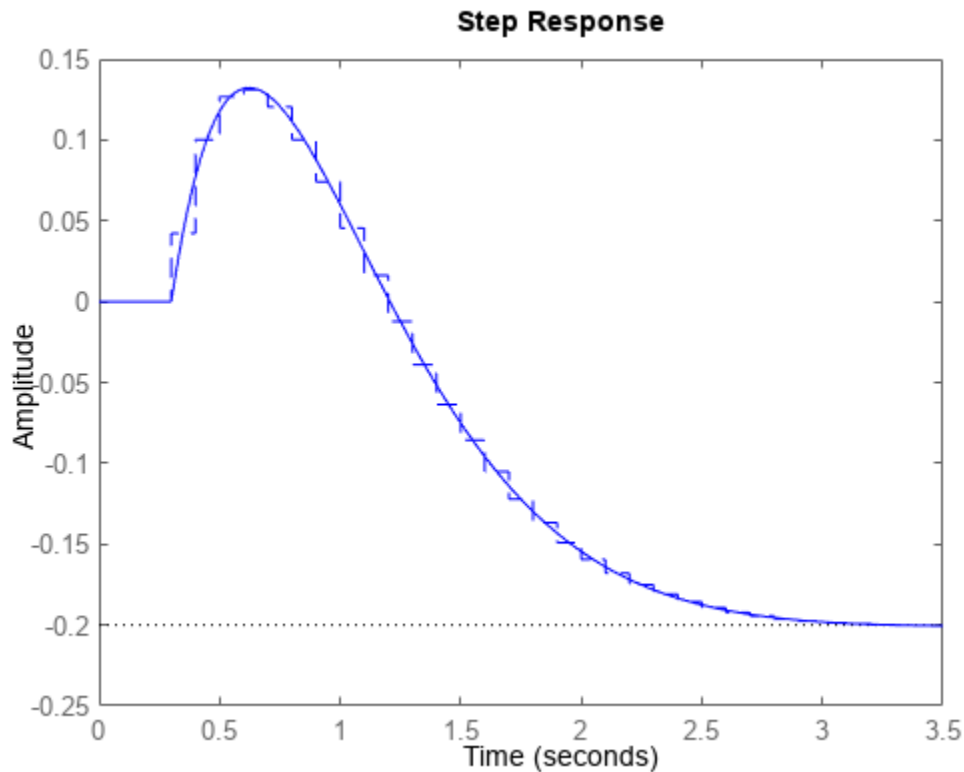

Discretize Model with Fractional Delay Absorbed into Coefficients

Discretize the following delayed transfer function using zero-order hold on the input, and a 10-Hz sampling rate.

$$H(s) = e^{-0.25s} \frac{10}{s^2 + 3s + 10}.$$

```
h = tf(10,[1 3 10],'IODElay',0.25);
hd = c2d(h,0.1)
```

hd =

$$z^{(-3)} * \frac{0.01187 z^2 + 0.06408 z + 0.009721}{z^2 - 1.655 z + 0.7408}$$

Sample time: 0.1 seconds
Discrete-time transfer function.

In this example, the discretized model `hd` has a delay of three sampling periods. The discretization algorithm absorbs the residual half-period delay into the coefficients of `hd`.

Compare the step responses of the continuous-time and discretized models.

```
step(h, 'd--',hd, 'd--')
```

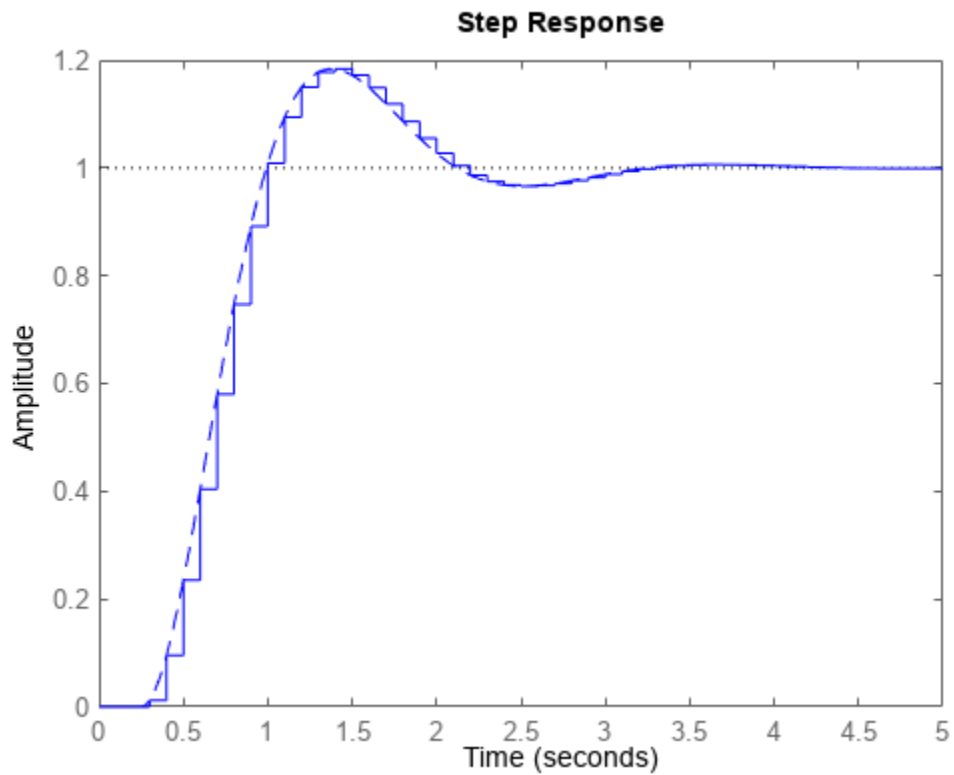

Discretize Model With Approximated Fractional Delay

Create a continuous-time state-space model with two states and an input delay.

```
sys = ss(tf([1,2],[1,4,2]));
sys.InputDelay = 2.7
```

```
sys =
```

```
A =
      x1  x2
x1 -4  -2
x2  1   0
```

```
B =
      u1
x1  2
x2  0
```

```
C =
      x1  x2
y1 0.5  1
```

```

D =
      u1
y1  0

Input delays (seconds): 2.7

Continuous-time state-space model.

Discretize the model using the Tustin discretization method and a Thiran filter to model fractional
delays. The sample time Ts = 1 second.

opt = c2dOptions('Method','tustin','FractDelayApproxOrder',3);
sysd1 = c2d(sys,1,opt)

sysd1 =

A =
      x1      x2      x3      x4      x5
x1  -0.4286  -0.5714  -0.00265  0.06954  2.286
x2   0.2857   0.7143  -0.001325  0.03477  1.143
x3    0         0      -0.2432   0.1449  -0.1153
x4    0         0         0.25      0         0
x5    0         0         0         0.125      0

B =
      u1
x1  0.002058
x2  0.001029
x3    8
x4    0
x5    0

C =
      x1      x2      x3      x4      x5
y1   0.2857   0.7143  -0.001325  0.03477  1.143

D =
      u1
y1  0.001029

```

Sample time: 1 seconds
Discrete-time state-space model.

The discretized model now contains three additional states x_3 , x_4 , and x_5 corresponding to a third-order Thiran filter. Since the time delay divided by the sample time is 2.7, the third-order Thiran filter ('FractDelayApproxOrder' = 3) can approximate the entire time delay.

Discretize Identified Model

Estimate a continuous-time transfer function, and discretize it.

```

load iddata1
sys1c = tfest(z1,2);
sys1d = c2d(sys1c,0.1,'zoh');

```

Estimate a second order discrete-time transfer function.

```
sys2d = tfest(z1,2,'Ts',0.1);
```

Compare the response of the discretized continuous-time transfer function model, `sys1d`, and the directly estimated discrete-time model, `sys2d`.

```
compare(z1,sys1d,sys2d)
```

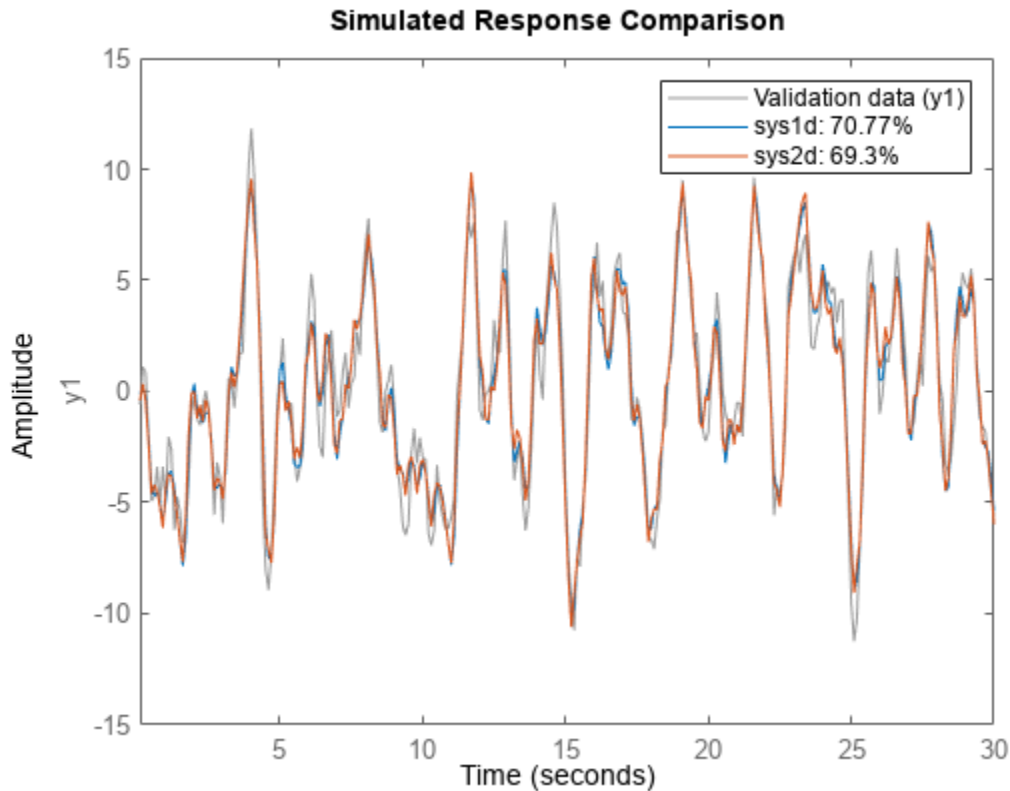

The two systems are almost identical.

Build Predictor Model

Discretize an identified state-space model to build a one-step ahead predictor of its response.

Create a continuous-time identified state-space model using estimation data.

```
load iddata2
sysc = ssest(z2,4);
```

Predict the 1-step ahead predicted response of `sysc`.

```
predict(sysc,z2)
```

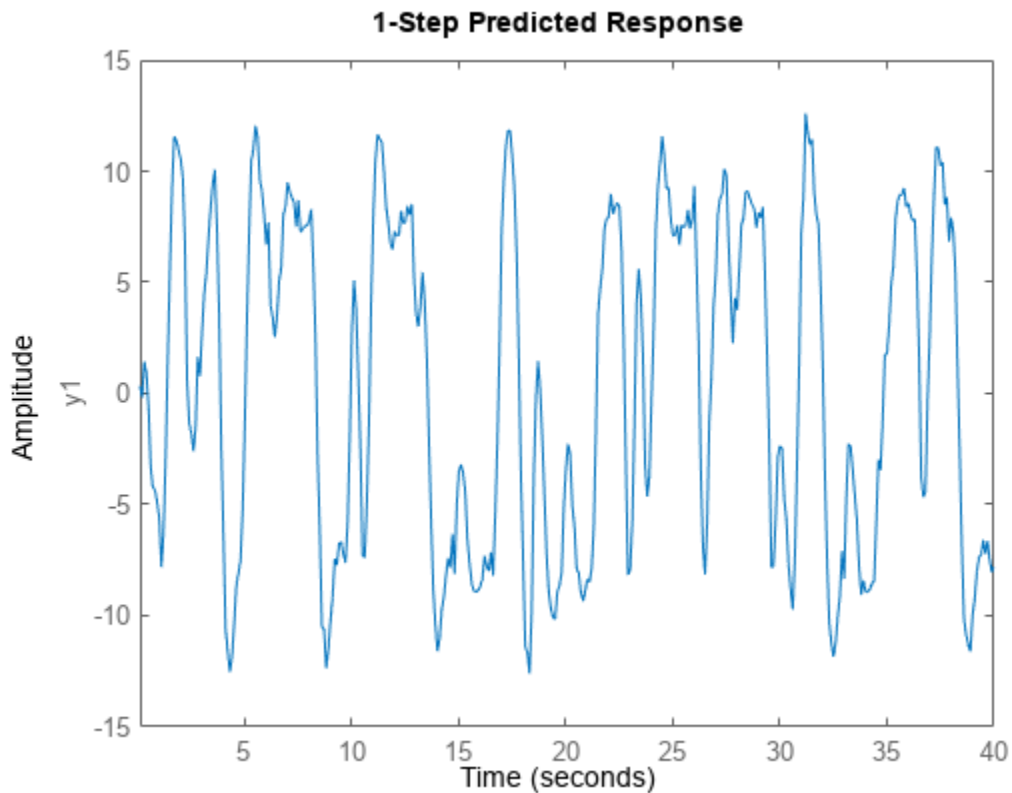

Discretize the model.

```
sysd = c2d(sysc,0.1,'zoh');
```

Build a predictor model from the discretized model, sysd.

```
[A,B,C,D,K] = idssdata(sysd);  
Predictor = ss(A-K*C,[K B-K*D],C,[0 D],0.1);
```

`Predictor` is a two-input model which uses the measured output and input signals (`[z1.y z1.u]`) to compute the 1-step predicted response of `sysc`.

Simulate the predictor model to get the same response as the `predict` command.

```
lsim(Predictor,[z2.y,z2.u])
```

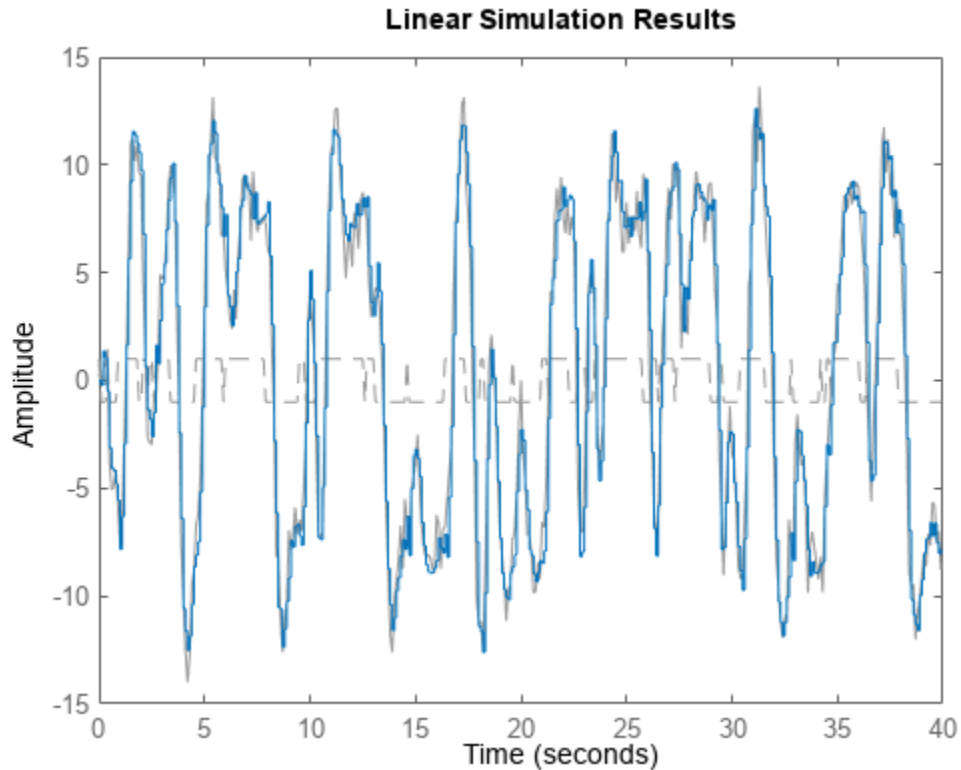

The simulation of the predictor model gives the same response as `predict(sysc,z2)`.

Input Arguments

sysc — Continuous-time dynamic system

dynamic system model

Continuous-time model, specified as a dynamic system model such as `tf`, `ss`, or `zpk`. `sysc` cannot be a frequency response data model. `sysc` can be a SISO or MIMO system, except that the 'matched' discretization method supports SISO systems only.

`sysc` can have input/output or internal time delays; however, the 'matched', 'impulse', and 'least-squares' methods do not support state-space models with internal time delays.

The following identified linear systems cannot be discretized directly:

- `idgrey` models whose `FunctionType` is 'c'. Convert to `idss` model first.
- `idproc` models. Convert to `idtf` or `idpoly` model first.

Ts — Sample time

positive scalar

Sample time, specified as a positive scalar that represents the sampling period of the resulting discrete-time system. `Ts` is in `TimeUnit`, which is the `sysc.TimeUnit` property.

method — Discretization method

'zoh' (default) | 'foh' | 'impulse' | 'tustin' | 'matched' | 'least-squares'

Discretization method, specified as one of the following values:

- 'zoh' — Zero-order hold (default). Assumes the control inputs are piecewise constant over the sample time T_s .
- 'foh' — Triangle approximation (modified first-order hold). Assumes the control inputs are piecewise linear over the sample time T_s .
- 'impulse' — Impulse invariant discretization
- 'tustin' — Bilinear (Tustin) method. To specify this method with frequency prewarping (formerly known as the 'prewarp' method), use the `PrewarpFrequency` option of `c2dOptions`.
- 'matched' — Zero-pole matching method
- 'least-squares' — Least-squares method
- 'damped' — Damped Tustin approximation based on the TRBDF2 formula for sparse models only.

For information about the algorithms for each conversion method, see “Continuous-Discrete Conversion Methods”.

opts — Discretization options

`c2dOptions` object

Discretization options, specified as a `c2dOptions` object. For example, specify the prewarp frequency, order of the Thiran filter or discretization method as an option.

Output Arguments**sysd — Discrete-time model**

dynamic system model

Discrete-time model, returned as a dynamic system model of the same type as the input system `sysc`.

When `sysc` is an identified (IDLTI) model, `sysd`:

- Includes both measured and noise components of `sysc`. The innovations variance λ of the continuous-time identified model `sysc`, stored in its `NoiseVariance` property, is interpreted as the intensity of the spectral density of the noise spectrum. The noise variance in `sysd` is thus λ/T_s .
- Does not include the estimated parameter covariance of `sysc`. If you want to translate the covariance while discretizing the model, use `translatecov`.

G — Mapping of continuous initial conditions of state-space model to discrete-time initial state vector

matrix

Mapping of continuous-time initial conditions x_0 and u_0 of the state-space model `sysc` to the discrete-time initial state vector `x[0]`, returned as a matrix. The mapping of initial conditions to the initial state vector is as follows:

$$x[0] = G \cdot \begin{bmatrix} x_0 \\ u_0 \end{bmatrix}$$

For state-space models with time delays, `c2d` pads the matrix `G` with zeroes to account for additional states introduced by discretizing those delays. See “Continuous-Discrete Conversion Methods” for a discussion of modeling time delays in discretized systems.

Version History

Introduced before R2006a

See Also

`c2dOptions` | `d2c` | `d2d` | `thiran` | `translatecov` | Convert Model Rate

Topics

“Dynamic System Models”

“Discretize a Compensator”

“Continuous-Discrete Conversion Methods”

c2dOptions

Create option set for continuous- to discrete-time conversions

Syntax

```
opts = c2dOptions
opts = c2dOptions('OptionName', OptionValue)
```

Description

`opts = c2dOptions` returns the default options for `c2d`.

`opts = c2dOptions('OptionName', OptionValue)` accepts one or more comma-separated name/value pairs that specify options for the `c2d` command. Specify *OptionName* inside single quotes.

Input Arguments

Name-Value Pair Arguments

Method

Discretization method, specified as one of the following values:

'zoh'	Zero-order hold, where <code>c2d</code> assumes the control inputs are piecewise constant over the sample time T_s .
'foh'	Triangle approximation (modified first-order hold), where <code>c2d</code> assumes the control inputs are piecewise linear over the sample time T_s . (See [1] on page 2-119, p. 228.)
'impulse'	Impulse-invariant discretization.
'tustin'	Bilinear (Tustin) approximation. By default, <code>c2d</code> discretizes with no prewarp and rounds any fractional time delays to the nearest multiple of the sample time. To include prewarp, use the <code>PrewarpFrequency</code> option. To approximate fractional time delays, use the <code>FractDelayApproxOrder</code> option.
'matched'	Zero-pole matching method. (See [1] on page 2-119, p. 224.) By default, <code>c2d</code> rounds any fractional time delays to the nearest multiple of the sample time. To approximate fractional time delays, use the <code>FractDelayApproxOrder</code> option.
'least-squares'	Least-squares method. Minimize the error between the frequency responses of the continuous-time and discrete-time systems up to the Nyquist frequency.

For information about the algorithms for each conversion method, see “Continuous-Discrete Conversion Methods”.

Default: 'zoh'

PrewarpFrequency

Prewarp frequency for 'tustin' method, specified in rad/TimeUnit, where TimeUnit is the time units, specified in the TimeUnit property, of the discretized system. Takes positive scalar values. A value of 0 corresponds to the standard 'tustin' method without prewarp.

Default: 0

FitOrder

Fit order for 'least-squares' method, specified as an integer. Specifies the order of the discrete-time model to be fitted to the continuous-time frequency response. Leave the default option 'auto' to use the order of the continuous-time model, and change it to an integer N to use an N^{th} -order fit. Reducing the order helps with unstable poles or pole/zero cancellations at $z = -1$.

Default: 'auto'

FractDelayApproxOrder

Maximum order of the Thiran filter used to approximate fractional delays in the 'tustin' and 'matched' methods. Takes integer values. A value of 0 means that c2d rounds fractional delays to the nearest integer multiple of the sample time.

Default: 0

Examples

Discretize Two Models Using Tustin Discretization Method

Generate two random continuous-time state-space models.

```
sys1 = rss(3,2,2);
sys2 = rss(4,4,1);
```

Create an option set for c2d to use the Tustin discretization method and 3.4 rad/s prewarp frequency.

```
opt = c2dOptions('Method','tustin','PrewarpFrequency',3.4);
```

Discretize the models, sys1 and sys2, using the same option set, but different sample times.

```
dsys1 = c2d(sys1,0.1,opt);
dsys2 = c2d(sys2,0.2,opt);
```

Version History

Introduced in R2010a

References

- [1] Franklin, G.F., Powell, D.J., and Workman, M.L., *Digital Control of Dynamic Systems* (3rd Edition), Prentice Hall, 1997.

See Also
c2d

canon

Canonical state-space realization

Syntax

```
csys = canon(sys,type)
csys = canon(sys,'modal',condt)
```

```
[csys,T]= canon( ___ )
```

Description

`csys = canon(sys,type)` transforms the linear model `sys` into a canonical state-space model `csys`. `type` specifies whether `csys` is in modal or companion form.

For information on controllable and observable canonical forms, see “State-Space Realizations”.

`csys = canon(sys,'modal',condt)` specifies an upper bound `condt` on the condition number of the block-diagonalizing transformation. Use `condt` if you have close lying eigenvalues in `csys`.

`[csys,T]= canon(___)` also returns the state-coordinate transformation matrix `T` that relates the states of the state-space model `sys` to the states of `csys`.

Examples

Convert State-Space Model to Companion Canonical Form

`aircraftPitchSSModel.mat` contains the state-space matrices of an aircraft where the input is elevator deflection angle δ and the output is the aircraft pitch angle θ .

$$\begin{bmatrix} \dot{\alpha} \\ \dot{q} \\ \dot{\theta} \end{bmatrix} = \begin{bmatrix} -0.313 & 56.7 & 0 \\ -0.0139 & -0.426 & 0 \\ 0 & 56.7 & 0 \end{bmatrix} \begin{bmatrix} \alpha \\ q \\ \theta \end{bmatrix} + \begin{bmatrix} 0.232 \\ 0.0203 \\ 0 \end{bmatrix} [\delta]$$

$$y = [0 \ 0 \ 1] \begin{bmatrix} \alpha \\ q \\ \theta \end{bmatrix} + [0][\delta]$$

Load the model data to the workspace and create the state-space model `sys`.

```
load('aircraftPitchSSModel.mat');
sys = ss(A,B,C,D)
```

`sys =`

```
A =
      x1      x2      x3
x1  -0.313    56.7      0
x2  -0.0139  -0.426      0
```

```

x3      0      56.7      0
B =
      u1
x1      0.232
x2      0.0203
x3      0
C =
      x1      x2      x3
y1      0      0      1
D =
      u1
y1      0

```

Continuous-time state-space model.

Convert the resultant state-space model `sys` to companion canonical form.

```
csys = canon(sys, 'companion')
```

```

csys =
A =
      x1      x2      x3
x1      0      0      -1.709e-16
x2      1      0      -0.9215
x3      0      1      -0.739
B =
      u1
x1      1
x2      0
x3      0
C =
      x1      x2      x3
y1      0      1.151      -0.6732
D =
      u1
y1      0

```

Continuous-time state-space model.

`csys` is the companion canonical form of `sys`.

Convert State-Space Model to Modal Canonical Form

`pendulumCartSSModel.mat` contains the state-space model of an inverted pendulum on a cart where the outputs are the cart displacement x and the pendulum angle θ . The control input u is the horizontal force on the cart.

$$\begin{bmatrix} \dot{x} \\ \ddot{x} \\ \dot{\theta} \\ \ddot{\theta} \end{bmatrix} = \begin{bmatrix} 0 & 1 & 0 & 0 \\ 0 & -0.1 & 3 & 0 \\ 0 & 0 & 0 & 1 \\ 0 & -0.5 & 30 & 0 \end{bmatrix} \begin{bmatrix} x \\ \dot{x} \\ \theta \\ \dot{\theta} \end{bmatrix} + \begin{bmatrix} 0 \\ 2 \\ 0 \\ 5 \end{bmatrix} u$$

$$y = \begin{bmatrix} 1 & 0 & 0 & 0 \\ 0 & 0 & 1 & 0 \end{bmatrix} \begin{bmatrix} x \\ \dot{x} \\ \theta \\ \dot{\theta} \end{bmatrix} + \begin{bmatrix} 0 \\ 0 \end{bmatrix} u$$

First, load the state-space model `sys` to the workspace.

```
load('pendulumCartSSModel.mat', 'sys');
```

Convert `sys` to modal canonical form and extract the transformation matrix.

```
[csys,T] = canon(sys, 'modal')
```

`csys =`

```
A =
      x1      x2      x3      x4
x1      0          0          0          0
x2      0     -0.05          0          0
x3      0          0     -5.503          0
x4      0          0          0     5.453

B =
      u1
x1  1.875
x2  6.298
x3  12.8
x4  12.05

C =
      x1      x2      x3      x4
y1    16     -4.763  -0.003696  0.003652
y2     0     0.003969  -0.03663  0.03685

D =
      u1
y1  0
y2  0
```

Continuous-time state-space model.

`T = 4x4`

```
0.0625    1.2500   -0.0000   -0.1250
0         4.1986    0.0210   -0.4199
0         0.2285  -13.5873    2.4693
0        -0.2251   13.6287    2.4995
```

`csys` is the modal canonical form of `sys`, while `T` represents the transformation between the state vectors of `sys` and `csys`.

Convert Zero-Pole-Gain Model to Modal Canonical Form

For this example, consider the following system with doubled poles and clusters of close poles:

$$\text{sys}(s) = 100 \frac{(s-1)(s+1)}{s(s+10)(s+10.0001)(s-(1+i))^2(s-(1-i))^2}$$

Create a zpk model of this system and convert it to modal canonical form using the string 'modal'.

```
sys = zpk([1 -1],[0 -10 -10.0001 1+1i 1-1i 1+1i 1-1i],100);
csys1 = canon(sys,'modal');
csys1.A
```

```
ans = 7×7
```

```

0         0         0         0         0         0         0
0    1.0000    2.1220         0         0         0         0
0   -0.4713    1.0000    1.5296         0         0         0
0         0         0    1.0000    1.8439         0         0
0         0         0   -0.5423    1.0000         0         0
0         0         0         0         0   -10.0000    4.0571
0         0         0         0         0         0   -10.0001
```

```
csys1.B
```

```
ans = 7×1
```

```

0.1600
-0.0052
0.0201
-0.0975
0.2884
0
4.0095
```

sys has a pair of poles at $s = -10$ and $s = -10.0001$, and two complex poles of multiplicity 2 at $s = 1+i$ and $s = 1-i$. As a result, the modal form csys1 is a state-space model with a block of size 2 for the two poles near $s = -10$, and a block of size 4 for the complex eigenvalues.

Now, separate the two poles near $s = -10$ by increasing the value of the condition number of the block-diagonalizing transformation. Use a value of $1e10$ for this example.

```
csys2 = canon(sys,'modal',1e10);
csys2.A
```

```
ans = 7×7
```

```

0         0         0         0         0         0         0
0    1.0000    2.1220         0         0         0         0
0   -0.4713    1.0000    1.5296         0         0         0
0         0         0    1.0000    1.8439         0         0
0         0         0   -0.5423    1.0000         0         0
0         0         0         0         0   -10.0000         0
```

```
0 0 0 0 0 0 -10.0001
```

```
format shortE
csys2.B
```

```
ans = 7×1

1.6000e-01
-5.1885e-03
2.0117e-02
-9.7508e-02
2.8844e-01
1.6267e+05
1.6267e+05
```

The A matrix of `csys2` includes separate diagonal elements for the poles near $s = -10$. Increasing the condition number results in some very large values in the B matrix.

Convert System to Companion Canonical Form

The file `icEngine.mat` contains one data set with 1500 input-output samples collected at the a sampling rate of 0.04 seconds. The input $u(t)$ is the voltage (V) controlling the By-Pass Idle Air Valve (BPAV), and the output $y(t)$ is the engine speed (RPM/100).

Use the data in `icEngine.mat` to create a state-space model with identifiable parameters.

```
load icEngine.mat
z = iddata(y,u,0.04);
sys = n4sid(z,4,'InputDelay',2);
```

Convert the identified state-space model `sys` to companion canonical form.

```
csys = canon(sys,'companion');
```

Obtain the covariance of the resulting form by running a zero-iteration update to model parameters.

```
opt = ssestOptions;
opt.SearchOptions.MaxIterations = 0;
csys = ssest(z,csys,opt);
```

Compare frequency response confidence bounds of `sys` to `csys`.

```
h = bodeplot(sys,csys,'r. ');
showConfidence(h)
```

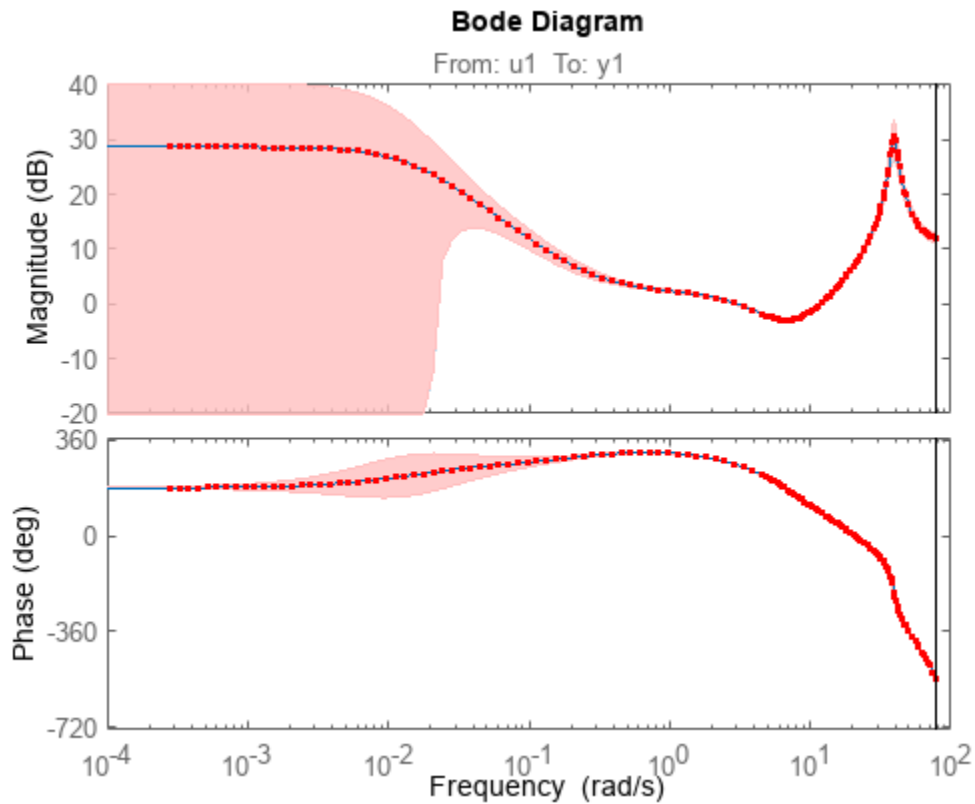

The frequency response confidence bounds are identical.

Input Arguments

sys — Dynamic system

dynamic system model

Dynamic system, specified as a SISO, or MIMO dynamic system model. Dynamic systems that you can use include:

- Continuous-time or discrete-time numeric LTI models, such as `tf`, `zpk`, `ss`, or `pid` models.
- Generalized or uncertain LTI models such as `genss` or `uss` models. (Using uncertain models requires Robust Control Toolbox software.)

The resulting canonical state-space model assumes

- current values of the tunable components for tunable control design blocks.
- nominal model values for uncertain control design blocks.
- Identified LTI models, such as `idtf`, `idss`, `idproc`, `idpoly`, and `idgrey` models. (Using identified models requires System Identification Toolbox software.)

You cannot use frequency-response data models such as `frd` models.

type — Transformation type

'modal' (default) | 'companion'

Transformation type, specified as either 'modal' or 'companion'. If type is unspecified, then canon converts the specified dynamic system model to modal canonical form by default.

The companion canonical form is the same as the observable canonical form. For information on controllable and observable canonical forms, see “State-Space Realizations”.

- *Modal Form*

In modal form, A is a block-diagonal matrix. The block size is typically 1-by-1 for real eigenvalues and 2-by-2 for complex eigenvalues. However, if there are repeated eigenvalues or clusters of nearby eigenvalues, the block size can be larger.

For example, for a system with eigenvalues $(\lambda_1, \sigma \pm j\omega, \lambda_2)$, the modal A matrix is of the form

$$A_m = \begin{bmatrix} \lambda_1 & 0 & 0 & 0 \\ 0 & \sigma & \omega & 0 \\ 0 & -\omega & \sigma & 0 \\ 0 & 0 & 0 & \lambda_2 \end{bmatrix}.$$

- *Companion Form*

In the companion realization, the characteristic polynomial of the system appears explicitly in the rightmost column of the A matrix. For a system with characteristic polynomial

$$P(s) = s^n + \alpha_{n-1}s^{n-1} + \alpha_{n-2}s^{n-2} + \dots + \alpha_1s + \alpha_0,$$

the corresponding companion A matrix is

$$A_{ccom} = \begin{bmatrix} 0 & 0 & 0 & \dots & 0 & -\alpha_0 \\ 1 & 0 & 0 & \dots & 0 & -\alpha_1 \\ 0 & 1 & 0 & \dots & 0 & -\alpha_2 \\ 0 & 0 & 1 & \dots & 0 & -\alpha_3 \\ \vdots & \vdots & \vdots & \ddots & \vdots & \vdots \\ 0 & 0 & 0 & \dots & 1 & -\alpha_{n-1} \end{bmatrix}, \quad B_{ccom} = \begin{bmatrix} 1 \\ 0 \\ \vdots \\ 0 \end{bmatrix}.$$

The companion transformation requires that the system is controllable from the first input. The transformation to companion form is based on the controllability matrix which is almost always numerically singular for mid-range orders. Hence, avoid using it when possible.

The companion canonical form is the same as the observable canonical form. For more information on observable and controllable canonical forms, see “State-Space Realizations”.

condt — Upper bound on the condition number of the block-diagonalizing transformation

1e4 (default) | positive scalar

Upper bound on the condition number of the block-diagonalizing transformation, specified as a positive scalar. This argument is available only when type is set to 'modal'.

Increase condt to reduce the size of the eigenvalue clusters in the A matrix of csys. Setting condt = Inf diagonalizes matrix A .

Output Arguments

csys — Canonical state-space form of the dynamic model

ss model object

Canonical state-space form of the dynamic model, returned as an *ss* model object. *csys* is a state-space realization of *sys* in the canonical form specified by *type*.

T — Transformation matrix

matrix

Transformation matrix, returned as an *n*-by-*n* matrix, where *n* is the number of states. *T* is the transformation between the state vector *x* of the state-space model *sys* and the state vector x_c of *csys*:

$$x_c = Tx$$

.

This argument is available only when *sys* is an *ss* model object.

Limitations

- You cannot use frequency-response data models to convert to canonical state-space form.
- The companion form is poorly conditioned for most state-space computations, that is, the transformation to companion form is based on the controllability matrix which is almost always numerically singular for mid-range orders. Hence, avoid using it when possible.

Algorithms

The `canon` command uses the `bdschur` command to convert *sys* into modal form and to compute the transformation *T*. If *sys* is not a state-space model, `canon` first converts it to state space using `ss`.

The reduction to companion form uses a state similarity transformation based on the controllability matrix [1].

Version History

Introduced before R2006a

Default value of `condt` input argument changed

Behavior changed in R2022a

The default value of `condt` input argument is now `1e4`. Previously, the default value was `1e8`. Increasing `condt` reduces the size of the eigenvalue clusters in the transformed model but also decreases the accuracy of the transformation. The new default value balances conditioning and transformation accuracy. If you have code that relies on the default value of `condt` being `1e8`, update your code to explicitly set this input argument.

References

[1] Kailath, T. *Linear Systems*, Prentice-Hall, 1980.

See Also

[ctrb](#) | [ctrbf](#) | [ss2ss](#) | [tf](#) | [zpk](#) | [ss](#) | [pid](#) | [genss](#) | [uss](#) | [idtf](#) | [idss](#) | [idproc](#) | [idpoly](#) | [idgrey](#)

Topics

“State-Space Realizations”

care

(Not recommended) Continuous-time algebraic Riccati equation solution

Note care is not recommended. Use `icare` instead. For more information, see “Compatibility Considerations”.

Syntax

```
[X,L,G] = care(A,B,Q)
[X,L,G] = care(A,B,Q,R,S,E)
[X,L,G,report] = care(A,B,Q,...)
[X1,X2,D,L] = care(A,B,Q,...,'factor')
```

Description

`[X,L,G] = care(A,B,Q)` computes the unique solution X of the continuous-time algebraic Riccati equation

$$A^T X + XA - XBB^T X + Q = 0$$

The `care` function also returns the gain matrix, $G = R^{-1}B^T XE$.

`[X,L,G] = care(A,B,Q,R,S,E)` solves the more general Riccati equation

$$A^T XE + E^T XA - (E^T XB + S)R^{-1}(B^T XE + S^T) + Q = 0$$

When omitted, R , S , and E are set to the default values $R=I$, $S=0$, and $E=I$. Along with the solution X , `care` returns the gain matrix $G = R^{-1}(B^T XE + S^T)$ and a vector L of closed-loop eigenvalues, where

$$L = \text{eig}(A - B * G, E)$$

`[X,L,G,report] = care(A,B,Q,...)` returns a diagnosis report with:

- -1 when the associated Hamiltonian pencil has eigenvalues on or very near the imaginary axis (failure)
- -2 when there is no finite stabilizing solution X
- The Frobenius norm of the relative residual if X exists and is finite.

This syntax does not issue any error message when X fails to exist.

`[X1,X2,D,L] = care(A,B,Q,...,'factor')` returns two matrices $X1$, $X2$ and a diagonal scaling matrix D such that $X = D * (X2 / X1) * D$.

The vector L contains the closed-loop eigenvalues. All outputs are empty when the associated Hamiltonian matrix has eigenvalues on the imaginary axis.

Examples

Example 1

Solve Algebraic Riccati Equation

Given

$$A = \begin{bmatrix} -3 & 2 \\ 1 & 1 \end{bmatrix} \quad B = \begin{bmatrix} 0 \\ 1 \end{bmatrix} \quad C = [1 \ -1] \quad R = 3$$

you can solve the Riccati equation

$$A^T X + XA - XBR^{-1}B^T X + C^T C = 0$$

by

```
a = [-3 2;1 1]
b = [0 ; 1]
c = [1 -1]
r = 3
[x,l,g] = care(a,b,c'*c,r)
```

This yields the solution

x

```
x =
    0.5895    1.8216
    1.8216    8.8188
```

You can verify that this solution is indeed stabilizing by comparing the eigenvalues of a and a-b*g.

```
[eig(a) eig(a-b*g)]
```

```
ans =
   -3.4495   -3.5026
    1.4495   -1.4370
```

Finally, note that the variable l contains the closed-loop eigenvalues eig(a-b*g).

l

```
l =
   -3.5026
   -1.4370
```

Example 2

Solve H-infinity (H_∞)-like Riccati Equation

To solve the H_∞ -like Riccati equation

$$A^T X + XA + X(\gamma^{-2}B_1B_1^T - B_2B_2^T)X + C^T C = 0$$

rewrite it in the care format as

$$A^T X + XA - X \begin{bmatrix} B_1 & B_2 \\ & B \end{bmatrix} \begin{bmatrix} -\nu^2 I & 0 \\ 0 & I \end{bmatrix}^{-1} \begin{bmatrix} B_1^T \\ B_2^T \end{bmatrix} X + C^T C = 0$$

You can now compute the stabilizing solution X by

```
B = [B1 , B2]
m1 = size(B1,2)
m2 = size(B2,2)
R = [-g^2*eye(m1) zeros(m1,m2) ; zeros(m2,m1) eye(m2)]
X = care(A,B,C'*C,R)
```

Limitations

The (A, B) pair must be stabilizable (that is, all unstable modes are controllable). In addition, the associated Hamiltonian matrix or pencil must have no eigenvalue on the imaginary axis. Sufficient conditions for this to hold are (Q, A) detectable when $S = 0$ and $R > 0$, or

$$\begin{bmatrix} Q & S \\ S^T & R \end{bmatrix} > 0$$

Algorithms

`care` implements the algorithms described in [1]. It works with the Hamiltonian matrix when R is well-conditioned and $E = I$; otherwise it uses the extended Hamiltonian pencil and QZ algorithm.

Version History

Introduced before R2006a

care is not recommended

Not recommended starting in R2019a

Starting in R2019a, use the `icare` command to solve continuous-time Riccati equations. This approach has improved accuracy through better scaling and the computation of K is more accurate when R is ill-conditioned relative to `care`. Furthermore, `icare` includes an optional `info` structure to gather the implicit solution data of the Riccati equation.

The following table shows some typical uses of `care` and how to update your code to use `icare` instead.

Not Recommended	Recommended
<code>[X,L,G] = care(A,B,Q,R,S,E)</code>	<code>[X,K,L] = icare(A,B,Q,R,S,E,G)</code> computes the stabilizing solution X , the state-feedback gain K and the closed-loop eigenvalues L of the continuous-time algebraic Riccati equation. For more information, see <code>icare</code> .

Not Recommended	Recommended
[X,L,G,report] = care(A,B,Q,R,S,E)	[X,K,L,info] = icare(A,B,Q,R,S,E,G) computes the stabilizing solution X, the state-feedback gain K, the closed-loop eigenvalues L of the continuous-time algebraic Riccati equation. The info structure contains the implicit solution data. For more information, see icare.

There are no plans to remove care at this time.

References

- [1] Arnold, W.F., III and A.J. Laub, "Generalized Eigenproblem Algorithms and Software for Algebraic Riccati Equations," *Proc. IEEE*, 72 (1984), pp. 1746-1754

See Also

icare

chgFreqUnit

Change frequency units of frequency-response data model

Syntax

```
sys_new = chgFreqUnit(sys,newfrequnits)
```

Description

`sys_new = chgFreqUnit(sys,newfrequnits)` changes units of the frequency points in `sys` to `newfrequnits`. Both `Frequency` and `FrequencyUnit` properties of `sys` adjust so that the frequency responses of `sys` and `sys_new` match.

Input Arguments

sys

Frequency-response data (`frd`, `idfrd`, or `genfrd`) model.

newfrequnits

New units of frequency points, specified as one of the following values:

- 'rad/TimeUnit'
- 'cycles/TimeUnit'
- 'rad/s'
- 'Hz'
- 'kHz'
- 'MHz'
- 'GHz'
- 'rpm'

`rad/TimeUnit` and `cycles/TimeUnit` express frequency units relative to the system time units specified in the `TimeUnit` property.

Default: 'rad/TimeUnit'

Output Arguments

sys_new

Frequency-response data model of the same type as `sys` with new units of frequency points. The frequency response of `sys_new` is same as `sys`.

Examples

Change Frequency Units of Frequency-Response Data Model

Create a frequency-response data model.

```
load('AnalyzerData');
sys = frd(resp,freq);
```

The data file `AnalyzerData` has column vectors `freq` and `resp`. These vectors contain 256 test frequencies and corresponding complex-valued frequency response points, respectively. The default frequency units of `sys` is `rad/TimeUnit`, where `TimeUnit` is the system time units.

Change the frequency units.

```
sys1 = chgFreqUnit(sys,'rpm');
```

The `FrequencyUnit` property of `sys1` is `rpm`.

Compare the Bode responses of `sys` and `sys1`.

```
bodeplot(sys,'r',sys1,'y--');
legend('sys','sys1')
```

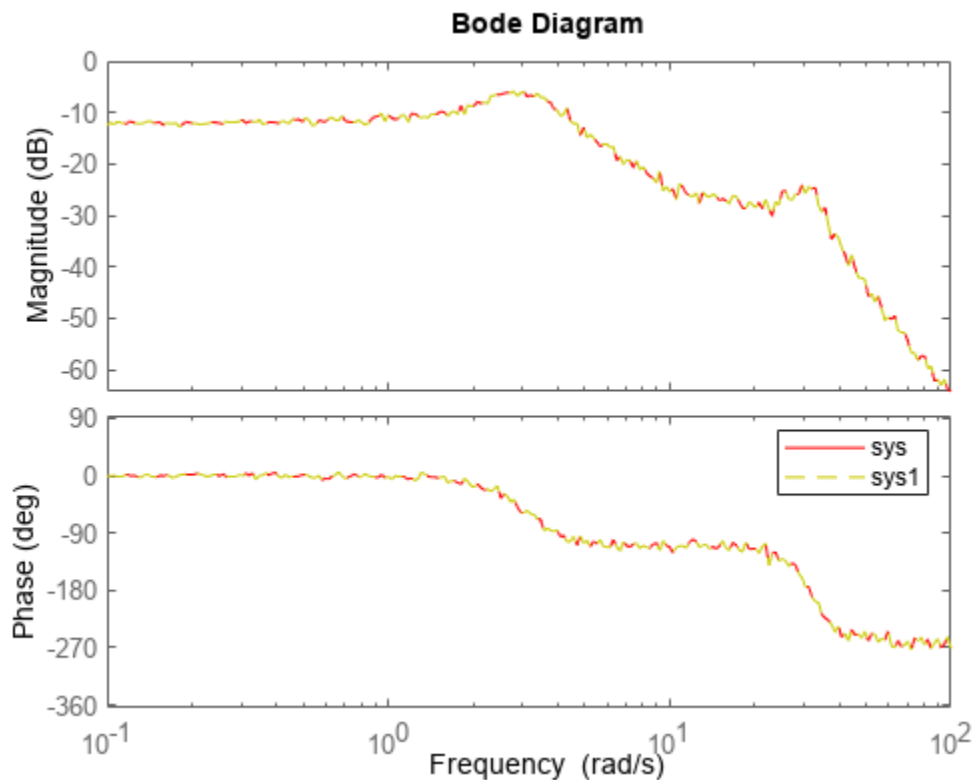

The magnitude and phase of `sys` and `sys1` match because `chgFreqUnit` command changes the units of frequency points in `sys` without modifying system behavior.

Change the `FrequencyUnit` property of `sys` to compare the Bode response with the original system.

```
sys2 = sys;
sys2.FrequencyUnit = 'rpm';
```

```
bodeplot(sys, 'r', sys2, 'gx');
legend('sys', 'sys2');
```

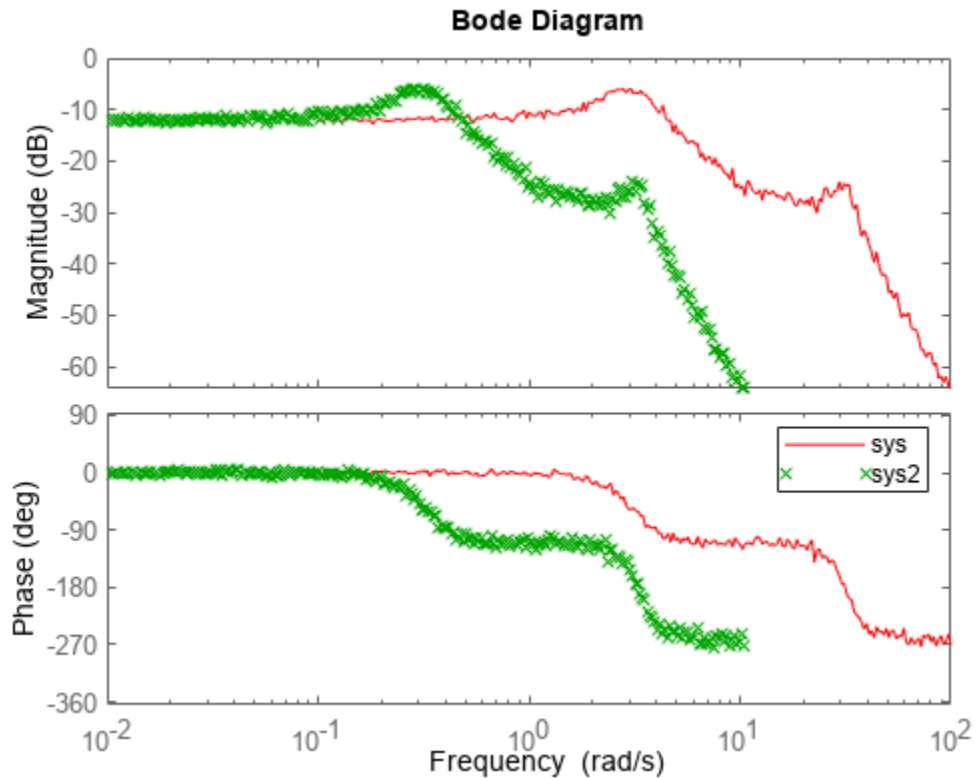

Changing the FrequencyUnit property changes the system behavior. Therefore, the Bode responses of sys and sys2 do not match. For example, the original corner frequency at about 2 rad/s changes to approximately 2 rpm (or 0.2 rad/s).

Tips

- Use `chgFreqUnit` to change the units of frequency points without modifying system behavior.

Version History

Introduced in R2011a

See Also

`chgTimeUnit` | `frd`

Topics

“Specify Frequency Units of Frequency-Response Data Model”

chgTimeUnit

Change time units of dynamic system

Syntax

```
sys_new = chgTimeUnit(sys,newtimeunits)
```

Description

`sys_new = chgTimeUnit(sys,newtimeunits)` changes the time units of `sys` to `newtimeunits`. The time- and frequency-domain characteristics of `sys` and `sys_new` match.

Input Arguments

`sys`

Dynamic system model

`newtimeunits`

New time units, specified as one of the following values:

- 'nanoseconds'
- 'microseconds'
- 'milliseconds'
- 'seconds'
- 'minutes'
- 'hours'
- 'days'
- 'weeks'
- 'months'
- 'years'

Default: 'seconds'

Output Arguments

`sys_new`

Dynamic system model of the same type as `sys` with new time units. The time response of `sys_new` is same as `sys`.

If `sys` is an identified linear model, both the model parameters as and their minimum and maximum bounds are scaled to the new time units.

Examples

Change Time Units of Dynamic System Model

Create a transfer function model.

```
num = [4 2];  
den = [1 3 10];  
sys = tf(num,den);
```

By default, the time unit of `sys` is 'seconds'. Create a new model with the time units changed to minutes.

```
sys1 = chgTimeUnit(sys, 'minutes');
```

This command sets the `TimeUnit` property of `sys1` to 'minutes', without changing the dynamics. To confirm that the dynamics are unchanged, compare the step responses of `sys` and `sys1`.

```
stepplot(sys, 'r', sys1, 'y--');  
legend('sys', 'sys1');
```

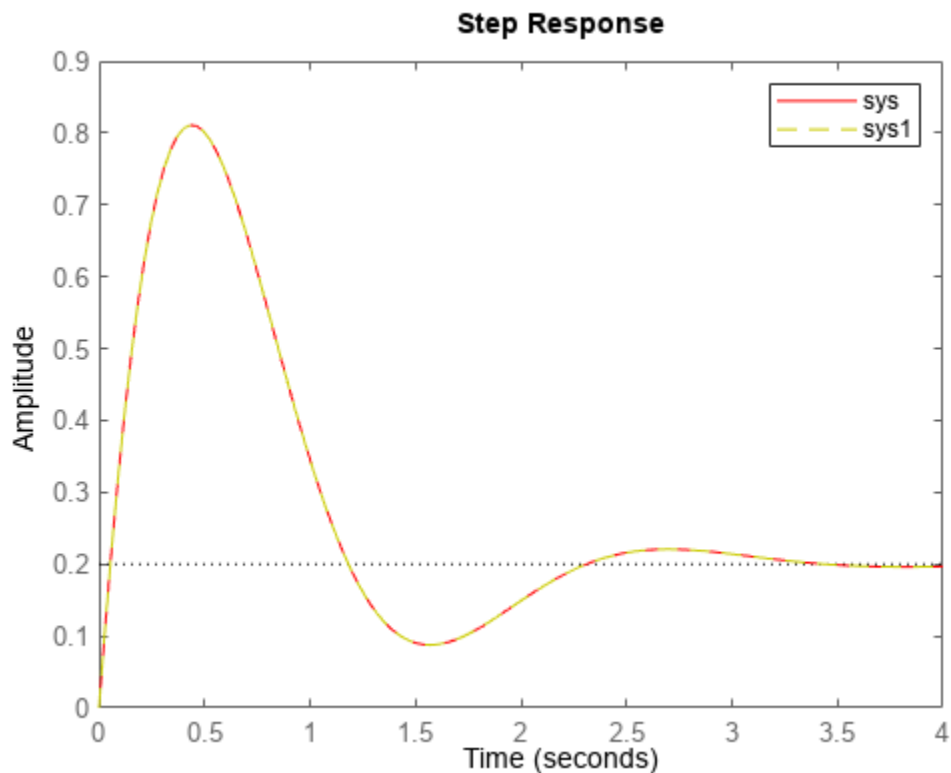

The step responses are the same.

If you change the `TimeUnit` property of the system instead of using `chgTimeUnit`, the dynamics of the system do change. To see this, change the `TimeUnit` property of a copy of `sys` and compare the step response with the original system.

```

sys2 = sys;
sys2.TimeUnit = 'minutes';
stepplot(sys, 'r', sys2, 'gx');
legend('sys', 'sys2');

```

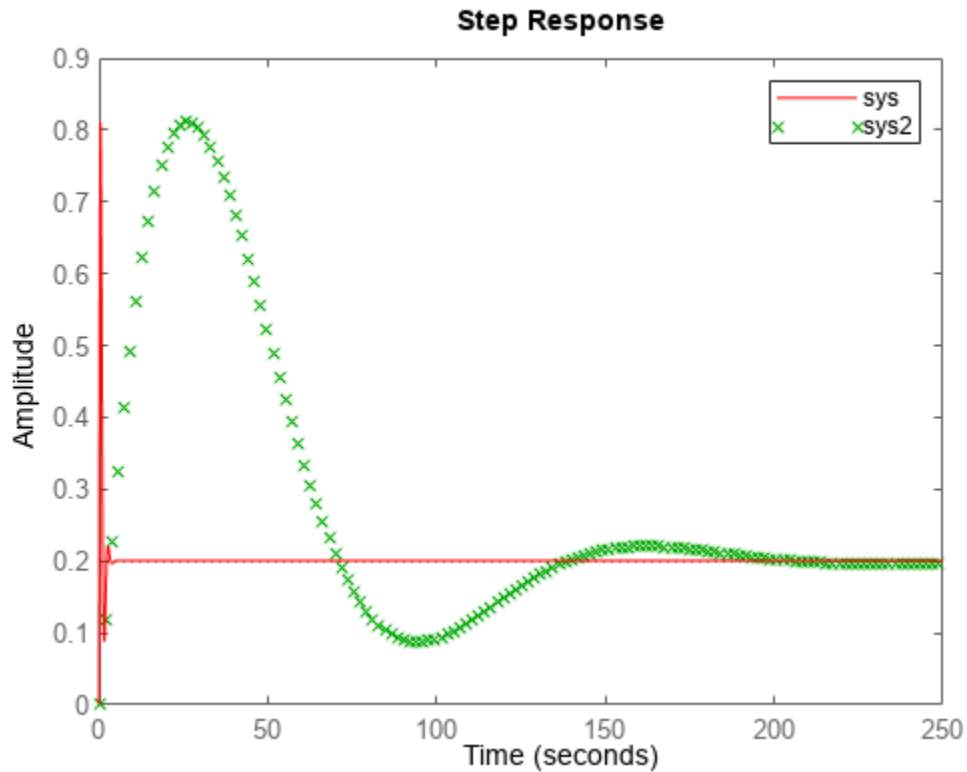

The step responses of `sys` and `sys2` do not match. For example, the original rise time of 0.04 seconds changes to 0.04 minutes.

Tips

- Use `chgTimeUnit` to change the time units without modifying system behavior.

Version History

Introduced in R2011a

See Also

`chgFreqUnit` | `tf` | `zpk` | `ss` | `frd` | `pid`

Topics

"Specify Model Time Units"

clone

Copy online state estimation object

Syntax

```
obj_clone = clone(obj)
```

Description

`obj_clone = clone(obj)` creates a copy of the online state estimation object `obj` with the same property values.

If you want to copy an existing object and then modify properties of the copied object, use the `clone` command. Do not create additional objects using syntax `obj2 = obj`. Any changes made to the properties of the new object created in this way (`obj2`) also change the properties of the original object (`obj`).

Examples

Clone an Online State Estimation Object

Create an extended Kalman filter object for a van der Pol oscillator with two states and one output. To create the object, use the previously written and saved state transition and measurement functions, `vdpStateFcn.m` and `vdpMeasurementFcn.m`. Specify the initial state values for the two states as `[2;0]`.

```
obj = extendedKalmanFilter(@vdpStateFcn,@vdpMeasurementFcn,[2;0])
```

```
obj =  
  extendedKalmanFilter with properties:  
    HasAdditiveProcessNoise: 1  
      StateTransitionFcn: @vdpStateFcn  
  HasAdditiveMeasurementNoise: 1  
      MeasurementFcn: @vdpMeasurementFcn  
  StateTransitionJacobianFcn: []  
  MeasurementJacobianFcn: []  
          State: [2x1 double]  
  StateCovariance: [2x2 double]  
      ProcessNoise: [2x2 double]  
  MeasurementNoise: 1  
  HasMeasurementWrapping: 0
```

Use `clone` to generate an object with the same properties as the original object.

```
obj2 = clone(obj)
```

```
obj2 =  
  extendedKalmanFilter with properties:
```

```

    HasAdditiveProcessNoise: 1
      StateTransitionFcn: @vdpStateFcn
  HasAdditiveMeasurementNoise: 1
    MeasurementFcn: @vdpMeasurementFcn
  StateTransitionJacobianFcn: []
  MeasurementJacobianFcn: []
    State: [2x1 double]
    StateCovariance: [2x2 double]
    ProcessNoise: [2x2 double]
  MeasurementNoise: 1
  HasMeasurementWrapping: 0

```

Modify the MeasurementNoise property of obj2.

```
obj2.MeasurementNoise = 2;
```

Verify that the MeasurementNoise property of original object obj remains unchanged and equals 1.

```
obj.MeasurementNoise
```

```
ans = 1
```

Input Arguments

obj — Object for online state estimation

extendedKalmanFilter object | unscentedKalmanFilter object | particleFilter object

Object for online state estimation of a nonlinear system, created using one of the following commands:

- extendedKalmanFilter
- unscentedKalmanFilter
- particleFilter

Output Arguments

obj_clone — Clone of online state estimation object

extendedKalmanFilter object | unscentedKalmanFilter object | particleFilter object

Clone of online state estimation object obj, returned as an extendedKalmanFilter, unscentedKalmanFilter or particleFilter object with the same properties as obj.

Version History

Introduced in R2016b

See Also

predict | correct | extendedKalmanFilter | unscentedKalmanFilter | particleFilter | initialize

codegen

Generate MATLAB code for tunable gain surfaces

Syntax

```
code = codegen(GS)
```

Description

`code = codegen(GS)` generates MATLAB code for the tunable surface `GS`. The generated code is a function that takes the scalar values of the scheduling variables and returns the scalar-valued or matrix-valued gain, depending on `GS`.

Examples

Generate Code from Tunable Surface

Create a tunable surface that represents a scalar gain with a bilinear dependence on two scheduling variables. Suppose that the scheduling variables are `alpha`, ranging from 0-15 degrees, and `V`, ranging from 300-600 m/s. The tunable surface covers a linearly spaced grid in this operating range.

```
[alpha,V] = ndgrid(0:3:15,300:50:600);
domain = struct('alpha',alpha,'V',V);
shapefcn = @(x,y) [x,y,x*y];
GS0 = tunableSurface('K',1,domain,shapefcn);
```

Usually, you use `GS0` to parameterize a scheduled gain and tune the surface coefficients with `systune`. For this example, instead of tuning, manually set the coefficients to non-zero values.

```
GS = setData(GS0,[100,28,40,10]);
```

Generate MATLAB code that computes the scalar gain as a function of scheduling variables.

```
code = codegen(GS)

code =
function Gain_ = fcn(alpha_,V_)
    %#codegen

    % Type casting
    ZERO = zeros(1,1,'like',alpha_+V_);
    alpha_ = cast(alpha_,'like',ZERO);
    V_ = cast(V_,'like',ZERO);

    % Tuned gain surface coefficients
    Coeffs = cast([100 28 40 10],'like',ZERO);
    Offsets = cast([7.5 450],'like',ZERO);
    Scalings = cast([7.5 150],'like',ZERO);

    % Normalization
    alpha_ = (alpha_ - Offsets(1))/Scalings(1);
```



```

V_ = (V_ - Offsets(2))/Scalings(2);

% Compute weighted sum of terms
Y = [ alpha_ , V_ , alpha_*V_ ];
Gain_ = Coeffs(1);
for i=1:numel(Y)
    Gain_ = Gain_ + Coeffs(i+1) * Y(i);
end

```

The resulting code is a function, `fcn`, that takes two scheduling variables and returns a scalar gain. The function includes the `%#codegen` directive, so that it can be used for further code generation, such as implementing a tuned gain schedule in hardware.

The function includes four sections. The first section ensures that the scheduling variables are cast to the same type. The second section encodes the gain coefficients and the offsets and scalings that the software extracts from GS. These values are hard-coded into `fcn`, which can compute the gain surface without reference to GS. The third section uses these values to compute the normalized scheduling variables. (See `tunableSurface` for more information about normalization.)

The last section computes the gain by summing up all the terms in the polynomial expression for the gain surface.

Input Arguments

GS — Tunable gain surface

`tunableSurface` object

Tunable gain surface, specified as a `tunableSurface` object.

Output Arguments

code — Generated code for gain surface

character array

Generated code for the gain surface, returned as a character array. The code contains a function, `Gain_ = fcn(x1_,x2_,...,xN_)`, that computes the gain from the scheduling variables `x1_,x2_,...,xN_` of GS. The expression relating the gain to the scheduling variables, the coefficients of the expression, and the normalization of the scheduling variables are all taken from GS, and the code can run without further reference to TS. The returned function includes the `%#codegen` directive so that it can be used for further code generation, such as implementing a tuned gain schedule in hardware.

When you use `writeBlockValue` to write tuned gain-surface coefficients from an `sLTuner` interface to a MATLAB Function block, it uses this generated MATLAB code.

Version History

Introduced in R2017b

See Also

tunableSurface

Topics

“Model Gain-Scheduled Control Systems in Simulink”

“Parameterize Gain Schedules”

conj

Form model with complex conjugate coefficients

Syntax

```
sysc = conj(sys)
```

Description

`sysc = conj(sys)` constructs a complex conjugate model `sysc` by applying complex conjugation to all coefficients of the LTI model `sys`. This function accepts LTI models in transfer function (TF), zero/pole/gain (ZPK), and state space (SS) formats.

Examples

If `sys` is the transfer function

```
(2+i)/(s+i)
```

then `conj(sys)` produces the transfer function

```
(2-i)/(s-i)
```

This operation is useful for manipulating partial fraction expansions.

Version History

Introduced before R2006a

See Also

`append` | `ss` | `tf` | `zpk`

connect

Block diagram interconnections of dynamic systems

Syntax

```
sysc = connect(sys1,...,sysN,inputs,outputs)
sysc = connect(sys1,...,sysN,inputs,outputs,APs)
sysc = connect(blksys,connections,inputs,outputs)
sysc = connect( ____,opts)
```

Description

`sysc = connect(sys1,...,sysN,inputs,outputs)` connects the block diagram elements `sys1,...,sysN` based on signal names. The block diagram elements `sys1,...,sysN` are dynamic system models. These models can include summing junctions that you create using `sumblk`. The `connect` command interconnects the block diagram elements by matching the input and output signals that you specify in the `InputName` and `OutputName` properties of `sys1,...,sysN`. The aggregate model `sysc` is a dynamic system model having inputs and outputs specified by `inputs` and `outputs` respectively.

`sysc = connect(sys1,...,sysN,inputs,outputs,APs)` inserts an `AnalysisPoint` at every signal location specified in `APs`. Use analysis points to mark locations of interest which are internal signals in the aggregate model. For instance, a location at which you want to extract a loop transfer function or measure the stability margins is a location of interest.

`sysc = connect(blksys,connections,inputs,outputs)` uses index-based interconnection to build `sysc` out of an aggregate, unconnected model `blksys`. The matrix `connections` specifies how the outputs and inputs of `blksys` interconnect. For index-based interconnections, `inputs` and `outputs` are index vectors that specify which inputs and outputs of `blksys` are the external inputs and outputs of `sysc`. This syntax can be convenient when you do not want to assign names to all inputs and outputs of all models to connect. However, in general, it is easier to keep track of named signals.

`sysc = connect(____,opts)` builds the interconnected model using additional options. You can use `opts` with the input arguments of any of the previous syntaxes.

Input Arguments

`sys1,...,sysN`

Dynamic system models that correspond to the elements of your block diagram. For example, the elements of your block diagram can include one or more `tf` or `ss` models that represent plant dynamics. Block diagram elements can also include a `pid` or `tunablePID` model representing a controller. You can also include one or more summing junction that you create using `sumblk`. Provide multiple arguments `sys1,...,sysN` to represent all of the block diagram elements and summing junctions.

inputs

For name-based interconnection, a character vector or cell array of character vectors that specify the inputs of the aggregate model `sysc`. The inputs in `inputs` must correspond to entries in the `InputName` or `OutputName` property of one or more of the block diagram elements `sys1, ..., sysN`.

outputs

For name-based interconnection, a character vector or cell array of character vectors that specify the outputs of the aggregate model `sysc`. The outputs in `outputs` must correspond to entries in the `OutputName` property of one or more of the block diagram elements `sys1, ..., sysN`.

APs

Locations (internal signals) of interest in the aggregate model, specified as a character vector or cell array of character vectors, such as `'X'` or `{'AP1', 'AP2'}`. The resulting model contains an analysis point at each such location. (See `AnalysisPoint`). Each location in `APs` must correspond to an entry in the `InputName` or `OutputName` property of one or more of the block diagram elements `sys1, ..., sysN`.

blksys

Unconnected aggregate model. To obtain `blksys`, use `append` to join dynamic system models of the elements of your block diagram. For example, if your block diagram contains dynamic system models `C`, `G`, and `S`, create `blksys` with the following command:

```
blksys = append(C,G,S)
```

connections

Matrix that specifies the connections and summing junctions of the block diagram. Each row of `connections` specifies one connection or summing junction in terms of the input vector `u` and output vector `y` of the unconnected aggregate model `blksys`. For example, the row:

```
[3 2 0 0]
```

specifies that `y(2)` connects into `u(3)`. The row

```
[7 2 -15 6]
```

indicates that `y(2) - y(15) + y(6)` feeds into `u(7)`.

If you do not specify any connection for a particular input or output, `connect` omits that input or output from the aggregate model.

opts

Additional options for interconnection, specified as an options set that you create with `connectOptions`.

Output Arguments**sysc**

Interconnected system, returned as either a state-space model or frequency-response model. The type of model returned depends on the input models. For example:

- Interconnecting numeric LTI models (other than `frd` models) returns an `ss` model.
- Interconnecting a numeric LTI model with a Control Design Block returns a generalized LTI model. For instance, interconnecting a `tf` model with a `tunablePID` Control Design Block returns a `genss`.
- Interconnecting any model with frequency-response data model returns a frequency response data model.

By default, `connect` automatically discards states that do not contribute to the I/O transfer function from the specified inputs to the specified outputs of the interconnected model. To retain the unconnected states, set the `Simplify` option of `connectOptions` to `false`. For example:

```
opt = connectOptions('Simplify',false);
sysc = connect(sys1,sys2,sys3,'r','y',opt);
```

Examples

SISO Feedback Loop

Create an aggregate model of the following block diagram from `r` to `y`.

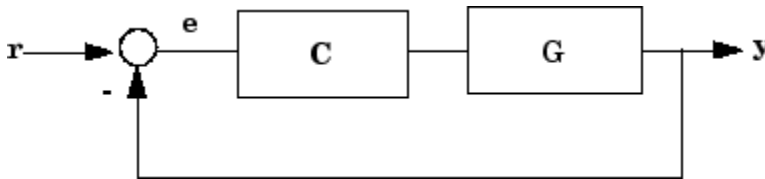

Create `C` and `G`, and name the inputs and outputs.

```
C = pid(2,1);
C.u = 'e';
C.y = 'u';
G = zpk([],[-1,-1],1);
G.u = 'u';
G.y = 'y';
```

The notations `C.u` and `C.y` are shorthand expressions equivalent to `C.InputName` and `C.OutputName`, respectively. For example, entering `C.u = 'e'` is equivalent to entering `C.InputName = 'e'`. The command sets the `InputName` property of `C` to the value `'e'`.

Create the summing junction.

```
Sum = sumblk('e = r - y');
```

Combine `C`, `G`, and the summing junction to create the aggregate model from `r` to `y`.

```
T = connect(G,C,Sum,'r','y');
```

`connect` automatically joins inputs and outputs with matching names.

MIMO Feedback Loop

Create the control system of the previous example where `G` and `C` are both 2-input, 2-output models.

```
C = [pid(2,1),0;0,pid(5,6)];
C.InputName = 'e';
```

```
C.OutputName = 'u';
G = ss(-1,[1,2],[1;-1],0);
G.InputName = 'u';
G.OutputName = 'y';
```

When you specify single names for vector-valued signals, the software automatically performs vector expansion of the signal names. For example, examine the names of the inputs to C.

```
C.InputName
```

```
ans =
```

```
'e(1)'  
'e(2)'
```

Create a 2-input, 2-output summing junction.

```
Sum = sumblk('e = r-y',2);
```

sumblk also performs vector expansion of the signal names.

Interconnect the models to obtain the closed-loop system.

```
T = connect(G,C,Sum,'r','y');
```

The block diagram elements G, C, and Sum are all 2-input, 2-output models. Therefore, connect performs the same vector expansion. connect selects all entries of the two-input signals 'r' and 'y' as inputs and outputs to T, respectively. For example, examine the input names of T.

```
T.InputName
```

```
ans =
```

```
'r(1)'  
'r(2)'
```

Feedback Loop With Analysis Point Inserted by connect

Create a model of the following block diagram from r to y . Insert an analysis point at an internal location, u .

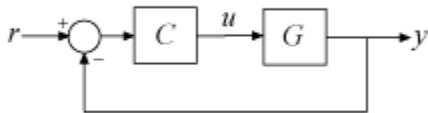

Create C and G, and name the inputs and outputs.

```
C = pid(2,1);
C.InputName = 'e';
C.OutputName = 'u';
G = zpk([],[-1,-1],1);
G.InputName = 'u';
G.OutputName = 'y';
```

Create the summing junction.

```
Sum = sumblk('e = r - y');
```

Combine C, G, and the summing junction to create the aggregate model, with an analysis point at *u*.

```
T = connect(G,C,Sum,'r','y','u')
```

T =

```
Generalized continuous-time state-space model with 1 outputs, 1 inputs, 3 states, and the following
AnalysisPoints_: Analysis point, 1 channels, 1 occurrences.
```

Type "ss(T)" to see the current value, "get(T)" to see all properties, and "T.Blocks" to interact

The resulting T is a genss model. The connect command creates the AnalysisPoint block, AnalysisPoints_, and inserts it into T. To see the name of the analysis point channel in AnalysisPoints_, use getPoints.

```
getPoints(T)
```

```
ans = 1x1 cell array
    {'u'}
```

The analysis point channel is named 'u'. You can use this analysis point to extract system responses. For example, the following commands extract the open-loop transfer at *u* and the closed-loop response at *y* to a disturbance injected at *u*.

```
L = getLoopTransfer(T,'u',-1);
Tuy = getIOTransfer(T,'u','y');
```

T is equivalent to the following block diagram, where AP_u designates the AnalysisPoint block AnalysisPoints_ with channel name *u*.

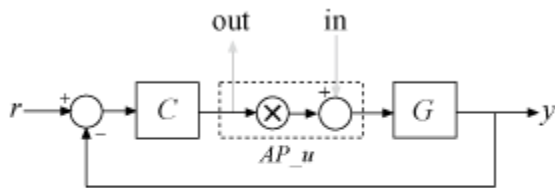

Index-Based Interconnection

Create an aggregate model of the following block diagram from *r* to *y* using index-based interconnection.

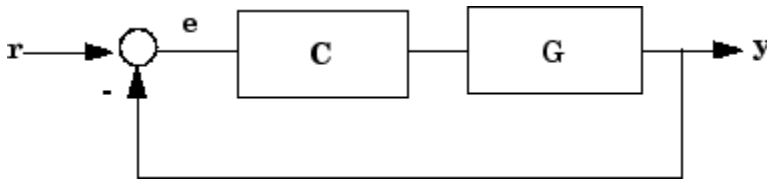

Create C, G, and the unconnected aggregate model blksys.

```
C = pid(2,1);
G = zpk([],[-1,-1],1);
blksys = append(C,G);
```

The inputs $u(1)$, $u(2)$ of blksys correspond to the inputs of C and G, respectively. The outputs $w(1)$, $w(2)$ of blksys correspond to the outputs of C and G, respectively.

Create the matrix connections, which specifies which outputs of blksys connect to which inputs of blksys.

```
connections = [2 1; 1 -2];
```

The first row indicates that $w(1)$ connects to $u(2)$; in other words, that the output of C connects to the input of G. The second row indicates that $-w(2)$ connects to $u(1)$; in other words, that the negative of the output of G connects to the input of C.

Create the connected aggregate model from r to y.

```
T = connect(blksys,connections,1,2)
```

The last two arguments specify the external inputs and outputs in terms of the indices of blksys. The argument 1 specifies that the external input connects to $u(1)$. The last argument, 2, specifies that the external output connects from $w(2)$.

Version History

Introduced before R2006a

See Also

sumblk | AnalysisPoint | append | feedback | parallel | series | lft | connectOptions

Topics

“Multi-Loop Control System”

“MIMO Control System”

“MIMO Feedback Loop”

“Mark Analysis Points in Closed-Loop Models”

connectOptions

Options for the connect command

Syntax

```
opt = connectOptions  
opt = connectOptions(Name,Value)
```

Description

`opt = connectOptions` returns the default options for connect.

`opt = connectOptions(Name,Value)` returns an options set with the options specified by one or more Name,Value pair arguments.

Examples

Retain Unconnected States in Model Interconnection

Use `connectOptions` to cause the connect command to retain unconnected states in an interconnected model.

Suppose you have dynamic system models `sys1`, `sys2`, and `sys3`. Combine these dynamic system models to build an interconnected model with input 'r' and output 'y'. Set the option to retain states in the model that do not contribute to the dynamics in the path from 'r' to 'y'.

```
opt = connectOptions('Simplify',false);  
sysc = connect(sys1,sys2,sys3,'r','y',opt);
```

Input Arguments

Name-Value Pair Arguments

Specify optional pairs of arguments as `Name1=Value1, ..., NameN=ValueN`, where `Name` is the argument name and `Value` is the corresponding value. Name-value arguments must appear after other arguments, but the order of the pairs does not matter.

Before R2021a, use commas to separate each name and value, and enclose Name in quotes.

Example: 'Simplify',false

Simplify — Automatic elimination of unconnected states

true (default) | false

Automatic elimination of unconnected states, specified as either true or false.

- `true` — connect eliminates all states that do not contribute to the I/O transfer function from the specified inputs to the specified outputs of the interconnected system.

- `false` — `connect` retains unconnected states. This option can be useful, for example, when you want to compute the interconnected system response from known initial state values of the components.

Data Types: `logical`

Output Arguments

opt — Options for `connect`
`connectOptions` options set

Options for `connect`, returned as a `connectOptions` options set. Use `opt` as the last argument to `connect` when interconnecting models.

Version History

Introduced in R2013b

See Also

`connect`

Control System Designer

Design single-input, single-output (SISO) controllers

Description

The **Control System Designer** app lets you design single-input, single-output (SISO) controllers for feedback systems modeled in MATLAB or Simulink (requires Simulink Control Design™ software).

Using this app, you can:

- Design controllers using:
 - Interactive Bode, root locus, and Nichols graphical editors for adding, modifying, and removing controller poles, zeros, and gains.
 - Automated PID, LQG, or IMC tuning.
 - Optimization-based tuning (requires Simulink Design Optimization™ software).
 - Automated loop shaping (requires Robust Control Toolbox software).
- Tune compensators for single-loop or multiloop control architectures.
- Analyze control system designs using time-domain and frequency-domain responses, such as step responses and pole-zero maps.
- Compare response plots for multiple control system designs.
- Design controllers for multimodel control applications.

Limitations

When using **Control System Designer** in MATLAB Online™, the following features are not available:

- Designing of controllers in Simulink
- Variable editor

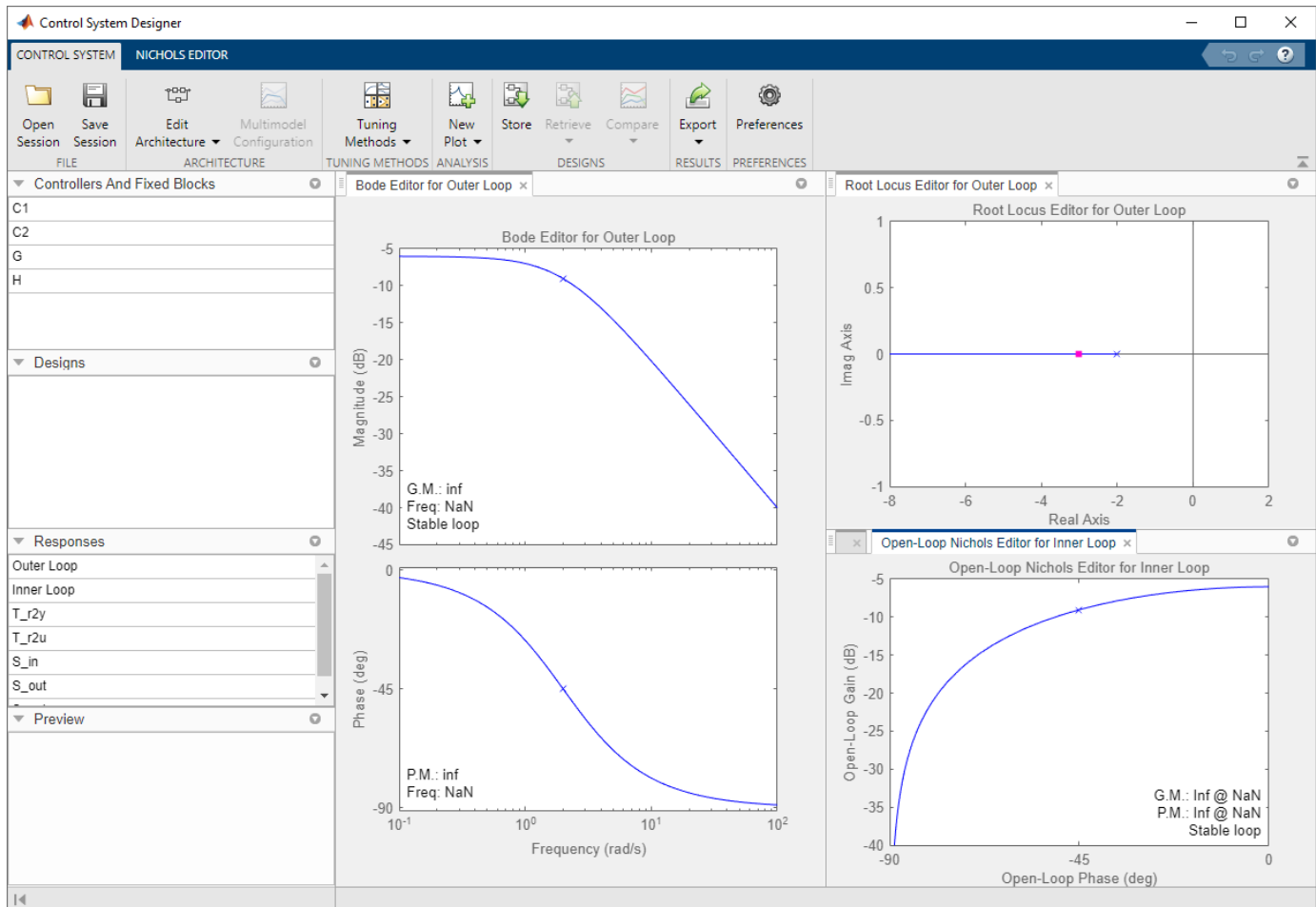

Open the Control System Designer App

- MATLAB Toolstrip: On the **Apps** tab, under **Control System Design and Analysis**, click the app icon.
- MATLAB command prompt: Enter `controlSystemDesigner`.
- Simulink Toolstrip: On the **Apps** tab, under **Control Systems**, click the app icon.

Examples

- “Control System Designer Tuning Methods”
- “Bode Diagram Design”
- “Root Locus Design”
- “Design Compensator Using Automated Tuning Methods”
- “Design Multiloop Control System”
- “Analyze Designs Using Response Plots”
- “Compare Performance of Multiple Designs”

- “Multimodel Control Design”

Programmatic Use

`controlSystemDesigner` opens the **Control System Designer** app using the following default control architecture:

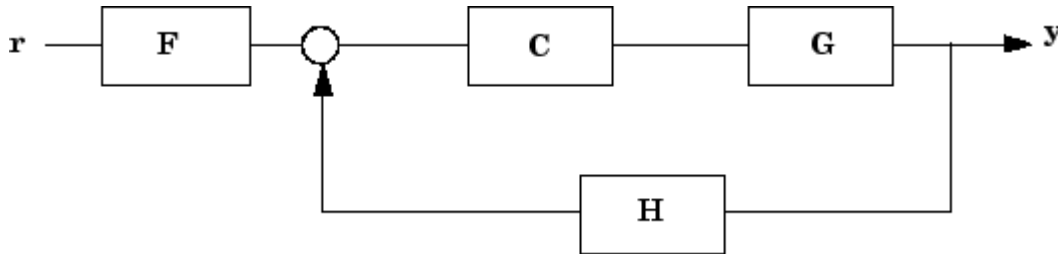

The architecture consists of the LTI objects:

- G — Plant model
- C — Compensator
- H — Sensor model
- F — Prefilter

By default, the app configures each of these models as a unit gain.

`controlSystemDesigner(plant)` initializes the plant, G , to `plant`. `plant` can be any SISO LTI model created with `ss`, `tf`, `zpk` or `frd`, or an array of such models.

`controlSystemDesigner(plant, comp)` initializes the compensator, C , to the SISO LTI model `comp`.

`controlSystemDesigner(plant, comp, sensor)` initializes the sensor model, H , to `sensor`. `sensor` can be any SISO LTI model or an array of such models. If you specify both `plant` and `sensor` as LTI model arrays, the lengths of the arrays must match.

`controlSystemDesigner(plant, comp, sensor, prefilt)` initializes the prefilter model, F , to the SISO LTI model `prefilt`.

`controlSystemDesigner(views)` opens the app and specifies the initial graphical editor configuration. `views` can be any of the following character vectors, or a cell array of multiple character vectors.

- `'rlocus'` — Root locus editor
- `'bode'` — Open-loop Bode Editor
- `'nichols'` — Open-loop Nichols Editor
- `'filter'` — Bode Editor for the closed-loop response from prefilter input to the plant output

In addition to opening the specified graphical editors, the app plots the closed-loop, input-output step response.

`controlSystemDesigner(views,plant,comp,sensor,prefilt)` specifies the initial plot configuration and initializes the plant, compensator, sensor, and prefilter using the specified models. If a model is omitted, the app uses the default value.

`controlSystemDesigner(initData)` opens the app and initializes the system configuration using the initialization data structure `initdata`. To create `initdata`, use `sisoinit`.

`controlSystemDesigner(sessionFile)` opens the app and loads a previously saved session. `sessionFile` is the name of a session data file on the MATLAB path. This data includes the current system architecture and plot configuration, and any designs and responses saved in the **Data Browser**.

To save a session, in the **Control System Designer** app, on the **Control System** tab, click  **Save Session**.

Version History

Introduced in R2015a

Support for opening SISO Design Tool sessions saved before release R2016a has been removed

Errors starting in R2021b

Support for opening SISO Design Tool sessions saved before release R2016a will be removed in release R2021b.

If you have sessions saved before release R2016a, open and resave the session files using **Control System Designer** in any release from R2016a through R2021a.

See Also

Apps

Control System Tuner

Functions

`pidTuner` | `sisoinit`

Topics

“Control System Designer Tuning Methods”

“Bode Diagram Design”

“Root Locus Design”

“Design Compensator Using Automated Tuning Methods”

“Design Multiloop Control System”

“Analyze Designs Using Response Plots”

“Compare Performance of Multiple Designs”

“Multimodel Control Design”

Control System Tuner

Tune fixed-structure control systems

Description

The **Control System Tuner** app tunes control systems modeled in MATLAB or Simulink (requires Simulink Control Design software). This app lets you tune any control system architecture to meet your design goals. You can tune multiple fixed-order, fixed-structure control elements distributed over one or more feedback loops.

Control System Tuner automatically tunes the controller parameters to satisfy the must-have requirements (design constraints) and to best meet the remaining requirements (objectives). The library of tuning goals lets you capture your design requirements in a form suitable for fast automated tuning. Available tuning goals include standard control objectives such as reference tracking, disturbance rejection, loop shapes, closed-loop damping, and stability margins.

Limitations

When using **Control System Tuner** in MATLAB Online, the following features are not available:

- Tuning of Simulink models
- Tuning reports
- Variable editor

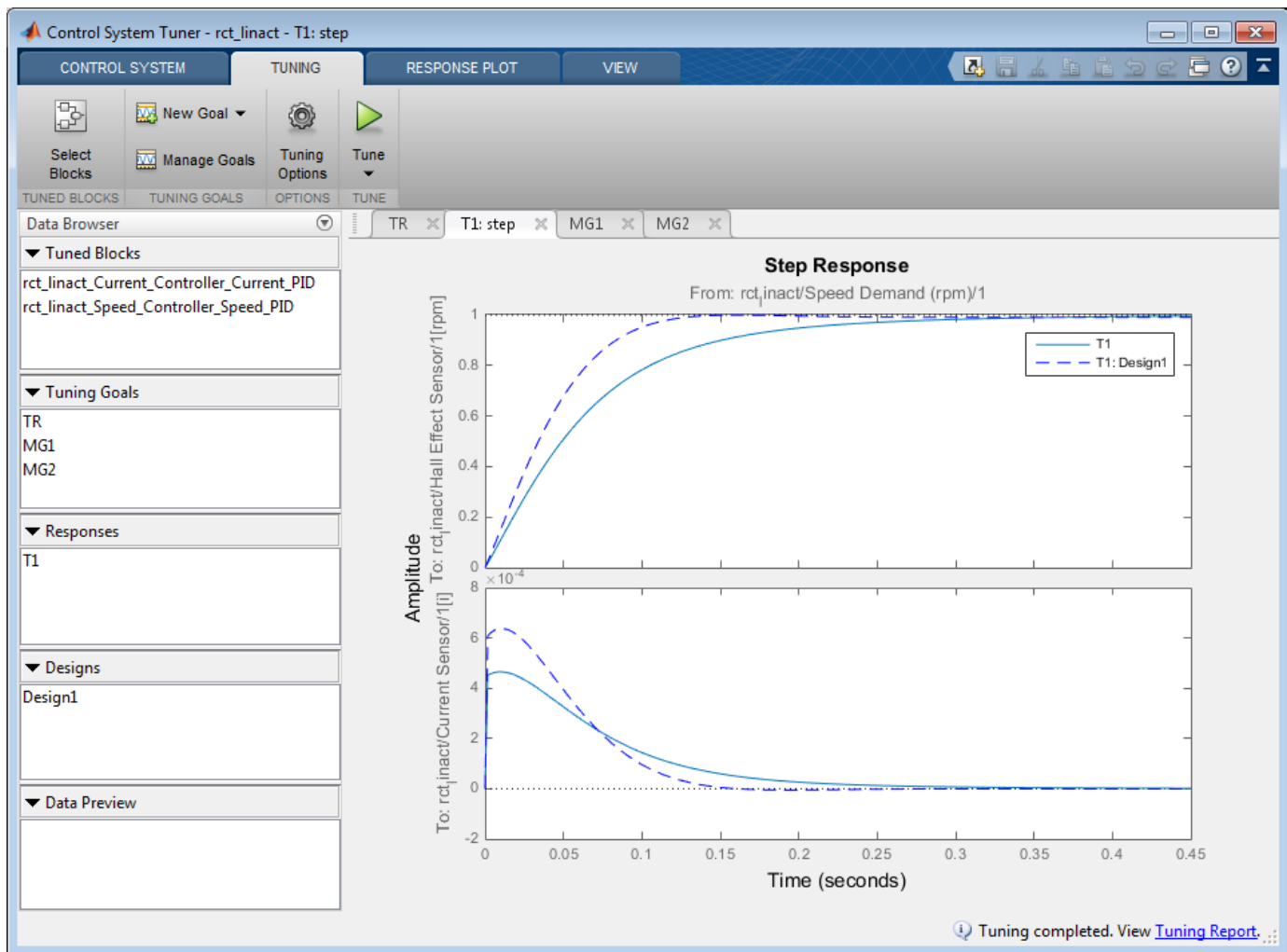

Open the Control System Tuner App

- MATLAB Toolstrip: On the **Apps** tab, under **Control System Design and Analysis**, click the app icon.
- MATLAB command prompt: Enter `controlSystemTuner`.
- Simulink Toolstrip: On the **Apps** tab, under **Control Systems**, click the app icon.

Examples

- “Setup for Tuning Control System Modeled in MATLAB”
- “Specify Control Architecture in Control System Tuner”
- “Tune a Control System Using Control System Tuner”

Programmatic Use

`controlSystemTuner` opens the Control System Tuner app. When invoked without input arguments, Control System Tuner opens for tuning the default single-loop feedback control system architecture. You can then edit the components of this default architecture as described in “Specify Control Architecture in Control System Tuner”.

`controlSystemTuner(CL)` opens the app for tuning the control architecture specified in the `genss` model `CL`. If your control architecture does not match Control System Tuner’s predefined control architecture, use this syntax with a `genss` model that has tunable components representing your controller elements. See “Specify Control Architecture in Control System Tuner”.

`controlSystemTuner mdl` opens the app for tuning blocks in a Simulink model. `mdl` is the name of a Simulink model saved in the current working directory or on the MATLAB path. (Requires Simulink Control Design software.)

`controlSystemTuner(ST)` opens the app for tuning a Simulink model associated with an `sLTuner` interface, `ST`. Control System Tuner takes information such as analysis points and operating points from `ST`. (Requires Simulink Control Design software.)

`controlSystemTuner(sessionfile)` opens the app and loads a previously saved session.

When you use Control System Tuner, you can click  **Save Session** to save session data to disk such as tuning goals you have created, response I/Os you have defined, operating points, and stored designs. `sessionfile` is the name of a session data file saved in the current working directory or on the MATLAB path.

Version History

Introduced in R2016a

Functionality moved from Robust Control Toolbox

Behavior changed in R2016a

Prior to R2016a, this functionality required a Robust Control Toolbox license.

See Also

Functions

`sys tune` | `sLTuner` | `genss`

Topics

“Setup for Tuning Control System Modeled in MATLAB”

“Specify Control Architecture in Control System Tuner”

“Tune a Control System Using Control System Tuner”

Convert Model Rate

Convert models between continuous time and discrete time and resample models in the Live Editor

Description

Convert Model Rate lets you interactively convert an LTI model between continuous time and discrete time. You can also use it to resample a discrete-time model. The task automatically generates MATLAB code for your live script.

To get started with the **Convert Model Rate** task, select the model you want to convert. You can also specify the target sample time, conversion method, and other parameters. The task generates the converted model in the MATLAB workspace, and can generate a response plot to let you monitor the match between the original and converted models as you experiment with conversion parameters.

Related Functions

Convert Model Rate generates code using the following functions.

- `c2d`
- `d2c`
- `d2d`

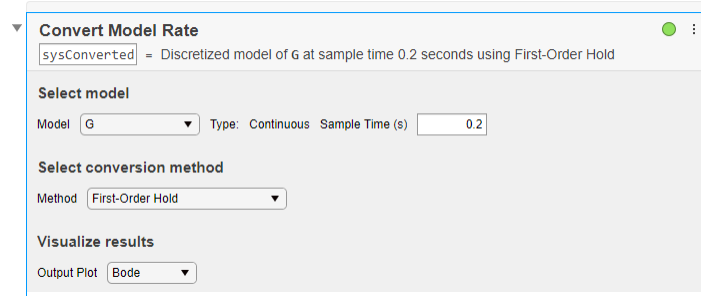

Description (collapsed portion)

Related Functions

Convert Model Rate generates code using the following functions.

- `c2d`
- `d2c`
- `d2d`

Open the Task

To add the **Convert Model Rate** task to a live script in the MATLAB Editor:

- On the **Live Editor** tab, select **Task > Convert Model Rate**.
- In a code block in your script, type a relevant keyword, such as `convert`, `rate`, or `c2d`. Select `Convert Model Rate` from the suggested command completions.

Examples

Discretize Model in the Live Editor

Use the **Convert Model Rate** task in the Live Editor to interactively convert a model from continuous time to discrete time. Experiment with different methods, options, and response plots. The task automatically generates code reflecting your selections. Open this example to see a preconfigured script containing the **Convert Model Rate** task.

Create a continuous-time transfer-function model.

```
G = tf([1 -50 300],[1 3 200 350]);
```

To discretize this model, open the **Convert Model Rate** task in the Live Editor. On the **Live Editor** tab, select **Task > Convert Model Rate**. In the task, select `G` as the model to convert.

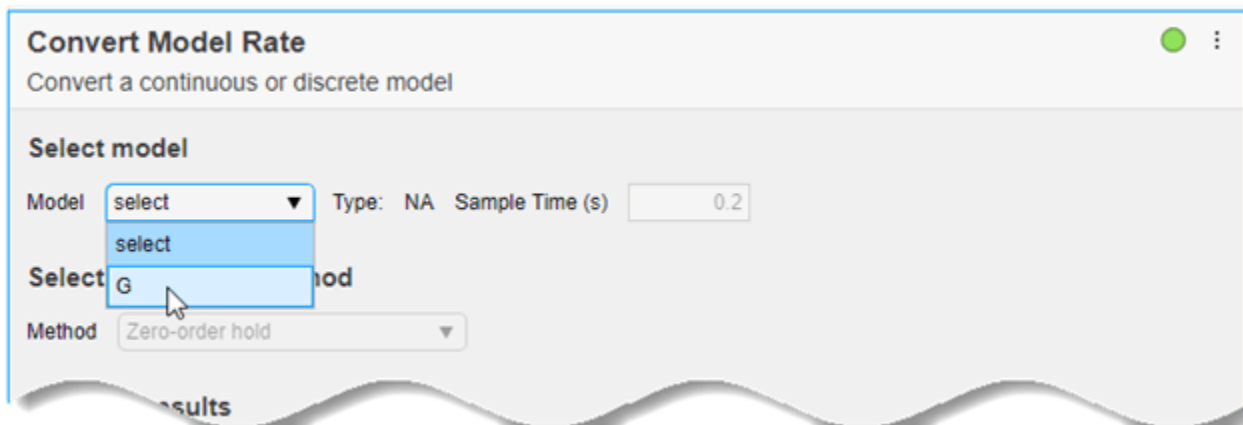

The task automatically discretizes the model using the default sample time, 0.2 s, and the default conversion method, Zero-order hold. It also creates a Bode plot, allowing you to compare the responses of the original and converted models.

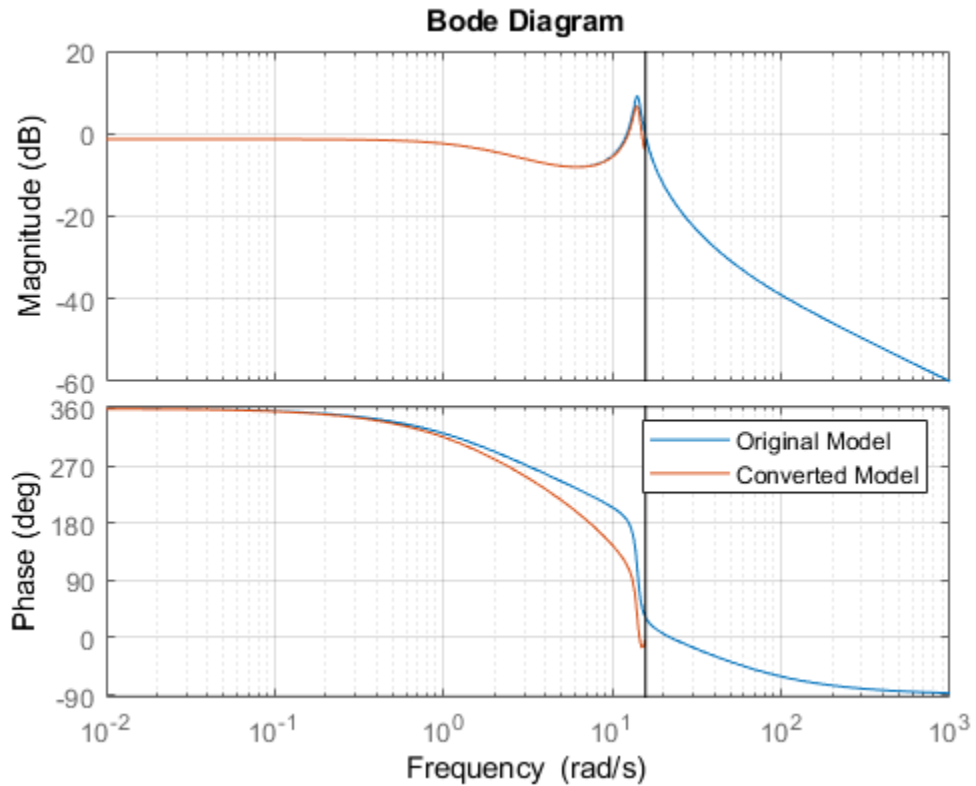

The vertical line on the plot shows the Nyquist frequency associated with the default sample time. Suppose you want to use a sample time of 0.15 seconds. Change the sample time by entering the new value in the **Sample Time** field. The response plot automatically updates to reflect the new sample time.

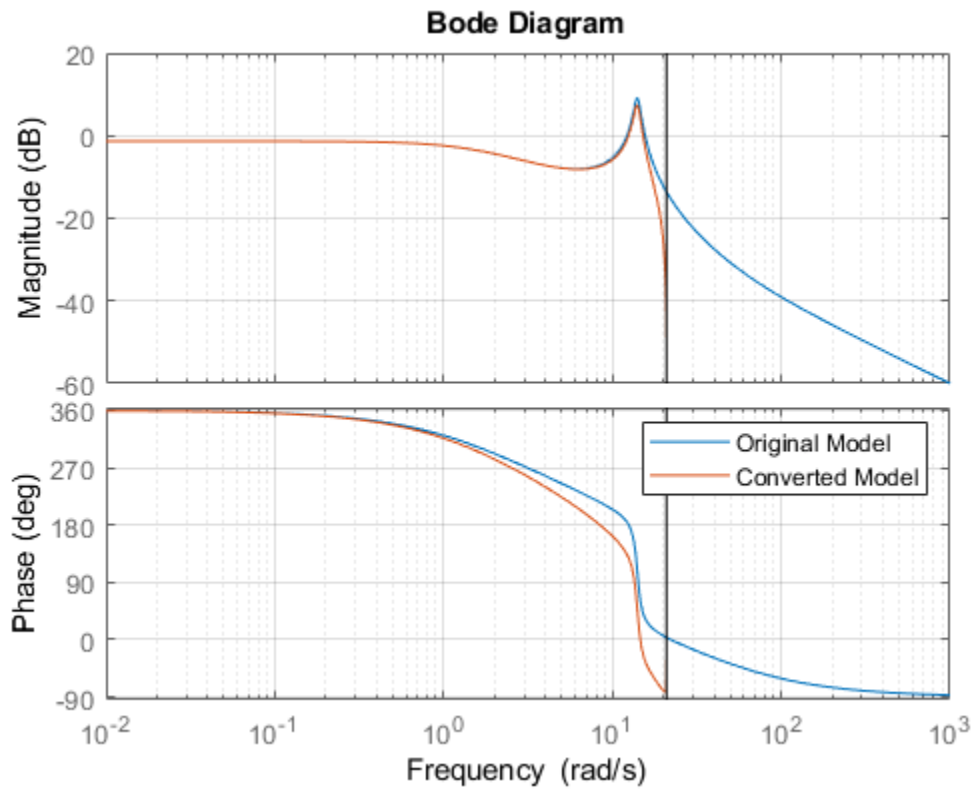

If the precise dynamics of the resonance are important for your application, you can improve the frequency-domain match using a different conversion method. In the task, try experimenting with different methods and observe their effect on the response plot.

The Tustin method can yield a better match in the frequency domain than the default zero-order hold method. (See “Continuous-Discrete Conversion Methods”.) In **Select Conversion Method**, select **Bilinear (Tustin) approximation**. Initially, the resulting frequency-domain match is poorer than with the zero-order hold method.

Select conversion method

Method Delay Order Prewarp Freq. (rad/s)

Visualize results

Output Plot

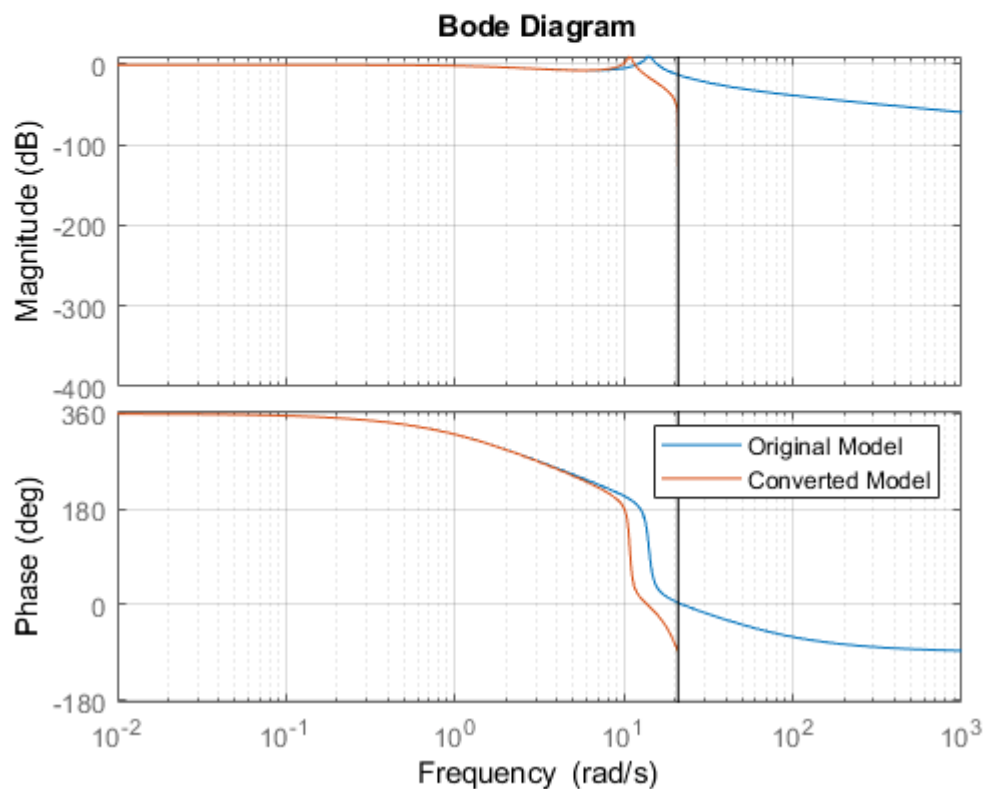

You can improve the match using a *prewarp frequency*. This option forces the discrete-time response to match at the frequency you specify. The resonance of G peaks at about 14 rad/s. Enter that value for the prewarp frequency. The match does improve around the resonance. However, the resonance is very close to the Nyquist frequency for the sample time of 0.15 s, which limits how close the match can be.

Select conversion method

Method Delay Order Prewarp Freq. (rad/s)

Visualize results

Output Plot

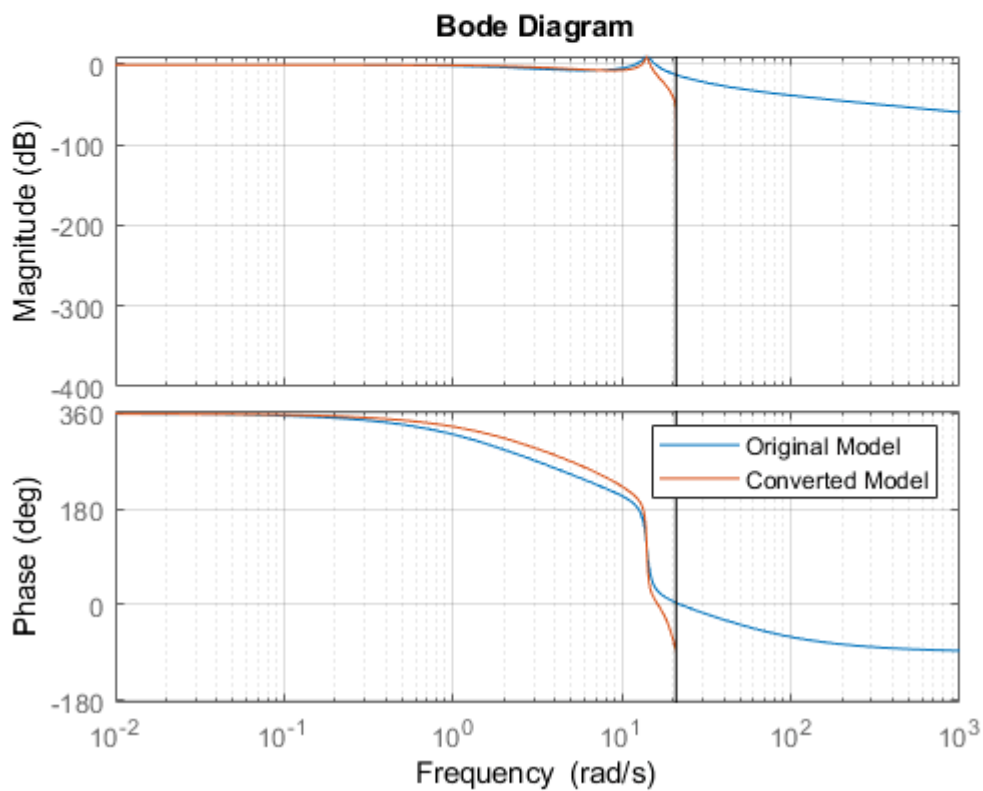

The **Convert Model Rate** task can generate other types of response plots. For instance, to compare the time-domain responses of the original and converted model, in **Output Plot**, select step or impulse.

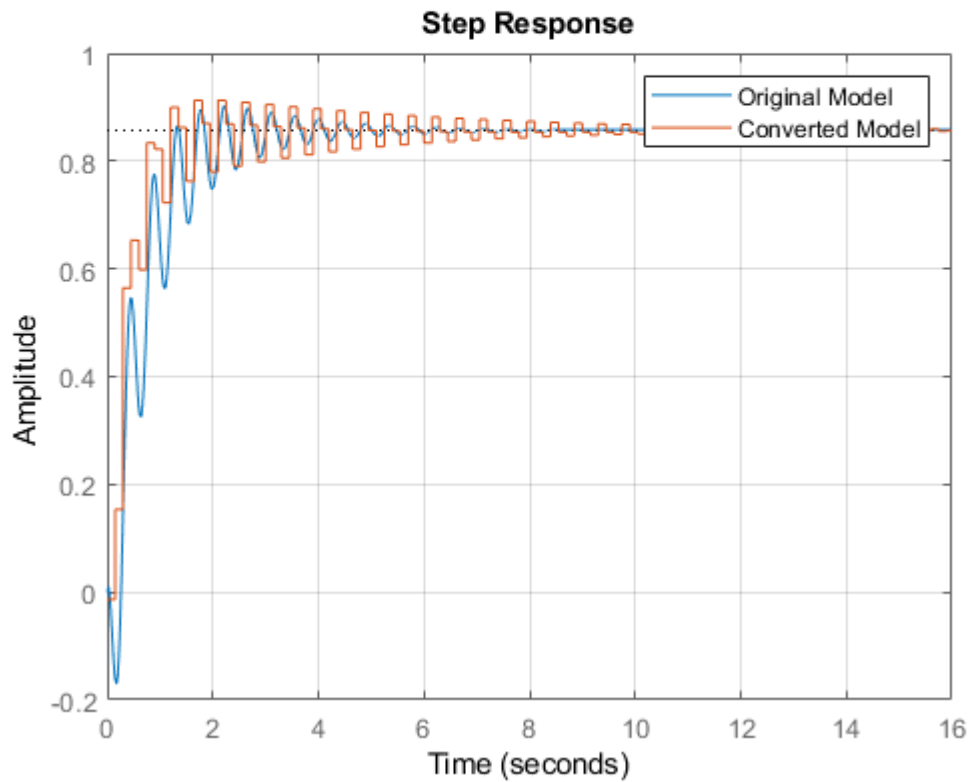

The task generates code in your live script. The generated code reflects the parameters and options you select, and includes code to generate the response plot you specify. To see the generated code, click  at the bottom of the task parameter area. The task expands to display the generated code.

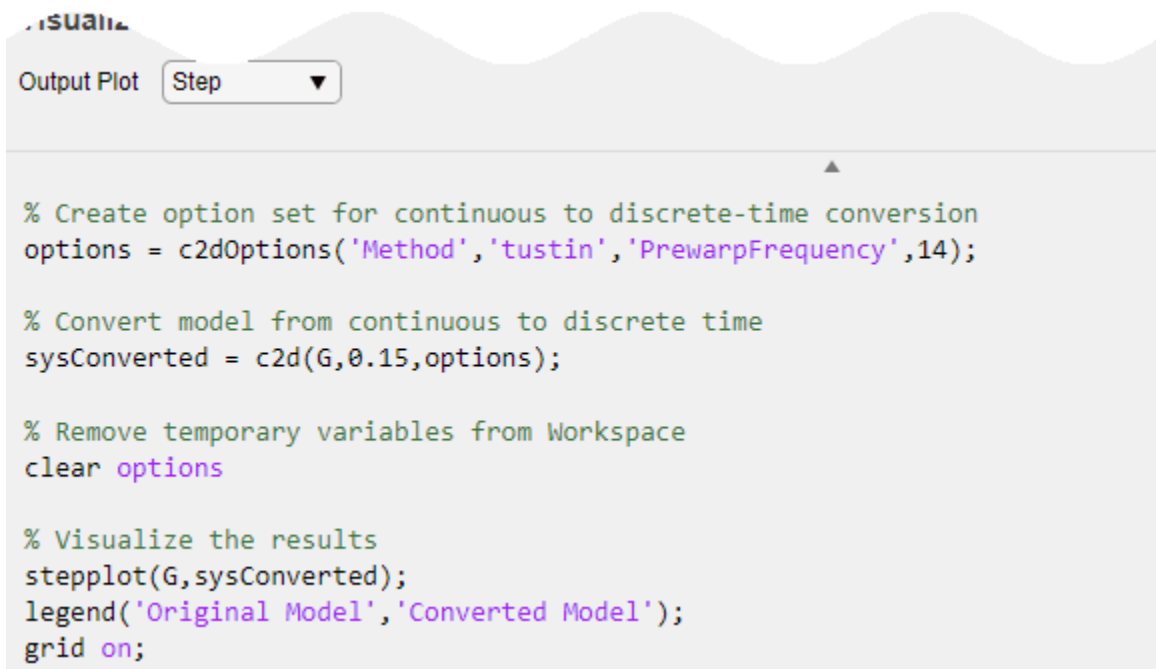

```

% Create option set for continuous to discrete-time conversion
options = c2dOptions('Method','tustin','PrewarpFrequency',14);

% Convert model from continuous to discrete time
sysConverted = c2d(G,0.15,options);

% Remove temporary variables from Workspace
clear options

% Visualize the results
stepplot(G,sysConverted);
legend('Original Model','Converted Model');
grid on;

```

By default, the generated code uses `sysConverted` as the name of the output variable. The converted model in the MATLAB® workspace using this name. To specify a different output variable name, enter a new name in the summary line at the top of the task. For instance, change the name to `sys_d`.

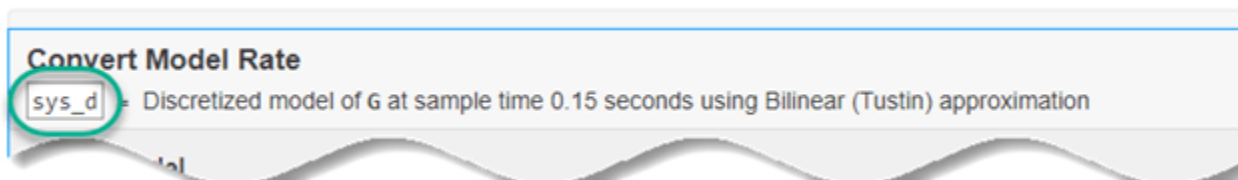

The task updates the generated code to reflect the new variable name, and the new converted model `sys_d` appears in the MATLAB workspace. You can use the model for further analysis or control design as you would any other model object. For instance, simulate the converted system's response to a square-wave input. Use the sample time you specified in the task.

```

[u,t] = gensig('square',4,10,0.15);
lsim(sys_d,u,t)

```

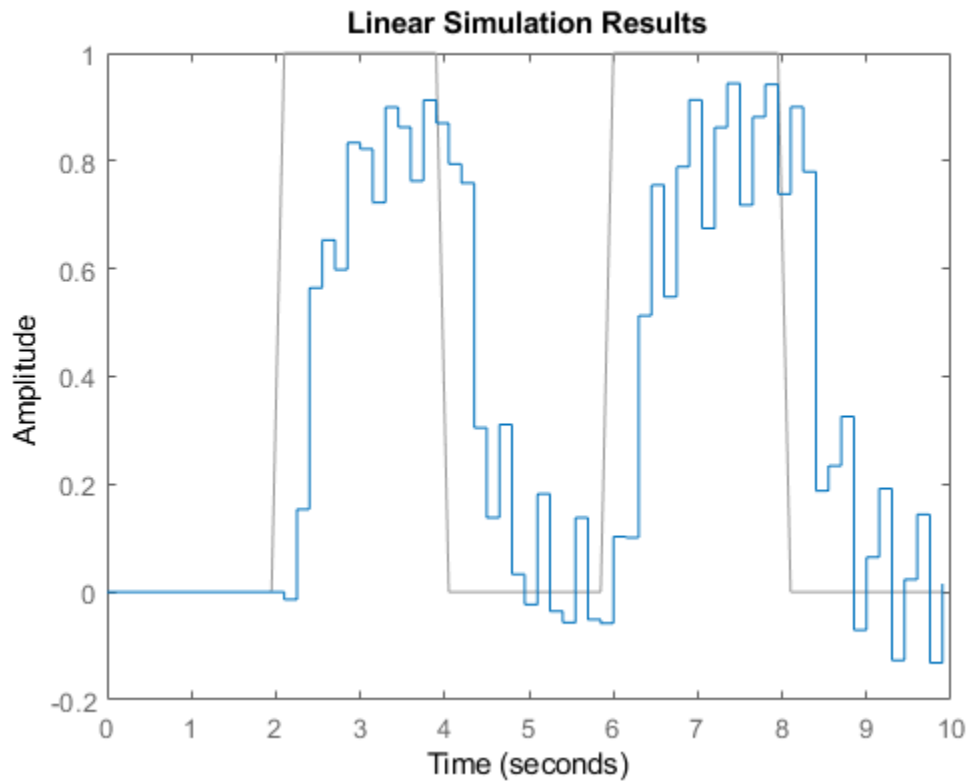

Parameters

Model — Model to convert

LTI model

Select an LTI model. The list contains all suitable continuous-time or discrete-time dynamic system models in the MATLAB workspace, including:

- Numeric LTI models such as `tf`, `ss`, or `zpk` models.
- Identified LTI models such as `idss` and `idtf`. (Using identified models requires a System Identification Toolbox license.)

You can convert SISO models or MIMO models, with or without time delays, although some conversion methods are only available for SISO models (see the **Method** parameter description). You cannot use **Convert Model Rate** to convert generalized LTI models such as `genss` or `uss`, frequency-response data models such as `frd`, or process models (`idproc`).

Sample Time — Target sample time

0.2 (default) | 0 | positive scalar

Specify the sample time of the converted model in units of $1/\text{TimeUnit}$, where `TimeUnit` is the `TimeUnit` property of the input model.

- To discretize a continuous-time model or resample a discrete-time model, enter the target sample time.

- To convert a discrete-time model to continuous time, enter 0.

Method — Rate conversion method

Zero-order hold (default) | First-order hold | Bilinear (Tustin) approximation | ...

Choose a rate conversion method. Available methods are:

- Zero-order hold
- First-order hold
- Impulse-invariant discretization (continuous-to-discrete conversion of SISO models only)
- Bilinear (Tustin) approximation
- Zero-pole matching method
- Least-squares method (continuous-to-discrete conversion of SISO models only)

For information about choosing a conversion method, see “Continuous-Discrete Conversion Methods”.

Delay Order — Approximate order for estimating time delay

0 (default) | positive integer

When you convert the rate of a model that has a time delay, the **Bilinear (Tustin) approximation** or **Zero-pole matching method** methods round the time delay to the nearest integer multiple of the sample time. This rounding can degrade the accuracy of dynamics, especially near the Nyquist frequency.

Set **Delay Order** to a nonzero integer to make **Convert Model Rate** approximate the fractional portion of the delay using a Thiran filter, instead of rounding. Use the smallest value that yields sufficiently accurate rate-converted dynamics for your application. For more information about Thiran filters, see `thiran`.

Prewarp Freq. (rad/s) — Prewarp frequency for bilinear (Tustin) method

0 (default) | positive scalar

When you discretize a continuous-time model, if your system has important dynamics at a particular frequency that you want the rate conversion to preserve, you can use the **Bilinear (Tustin) approximation** method with frequency prewarping. This method ensures a match between the original and converted responses at the prewarp frequency you specify. See “Continuous-Discrete Conversion Methods”.

Output Plot — Type of response plot

Bode (default) | Step | Impulse | ...

Convert Model Rate automatically generates a response plot to help you check that the dynamics important to your application are preserved. Specify one of the following response plot types to compare the responses of the original and converted models while you experiment with conversion parameters.

- Bode
- Step
- Impulse
- Pole-Zero

The code generated by the task includes code to create the selected response plot. To omit the response plot, select None.

Version History

Introduced in R2019b

See Also

c2d | d2c | d2d

Topics

“Continuous-Discrete Conversion Methods”

correct

Correct state and state estimation error covariance using extended or unscented Kalman filter, or particle filter and measurements

Syntax

```
[CorrectedState,CorrectedStateCovariance] = correct(obj,y)
[CorrectedState,CorrectedStateCovariance] = correct(obj,y,Um1,...,Umn)
```

Description

The `correct` command updates the state and state estimation error covariance of an `extendedKalmanFilter`, `unscentedKalmanFilter` or `particleFilter` object using measured system outputs. To implement extended or unscented Kalman filter, or particle filter, use the `correct` and `predict` commands together. If the current output measurement exists, you can use `correct` and `predict`. If the measurement is missing, you can only use `predict`. For information about the order in which to use the commands, see “Using predict and correct Commands” on page 2-179.

`[CorrectedState,CorrectedStateCovariance] = correct(obj,y)` corrects the state estimate and state estimation error covariance of an extended or unscented Kalman filter, or particle filter object `obj` using the measured output `y`.

You create `obj` using the `extendedKalmanFilter`, `unscentedKalmanFilter` or `particleFilter` commands. You specify the state transition function and measurement function of your nonlinear system in `obj`. You also specify whether the process and measurement noise terms are additive or nonadditive in these functions. The `State` property of the object stores the latest estimated state value. Assume that at time step `k`, `obj.State` is $\hat{x}[k|k-1]$. This value is the state estimate for time `k`, estimated using measured outputs until time `k-1`. When you use the `correct` command with measured system output `y[k]`, the software returns the corrected state estimate $\hat{x}[k|k]$ in the `CorrectedState` output. Where $\hat{x}[k|k]$ is the state estimate at time `k`, estimated using measured outputs until time `k`. The command returns the state estimation error covariance of $\hat{x}[k|k]$ in the `CorrectedStateCovariance` output. The software also updates the `State` and `StateCovariance` properties of `obj` with these corrected values.

Use this syntax if the measurement function `h` that you specified in `obj.MeasurementFcn` has one of the following forms:

- $y(k) = h(x(k))$ — for additive measurement noise.
- $y(k) = h(x(k),v(k))$ — for nonadditive measurement noise.

Where $y(k)$, $x(k)$, and $v(k)$ are the measured output, states, and measurement noise of the system at time step `k`. The only inputs to `h` are the states and measurement noise.

`[CorrectedState,CorrectedStateCovariance] = correct(obj,y,Um1,...,Umn)` specifies additional input arguments, if the measurement function of the system requires these inputs. You can specify multiple arguments.

Use this syntax if the measurement function `h` has one of the following forms:

- $y(k) = h(x(k), U_{m1}, \dots, U_{mn})$ — for additive measurement noise.
- $y(k) = h(x(k), v(k), U_{m1}, \dots, U_{mn})$ — for nonadditive measurement noise.

`correct` command passes these inputs to the measurement function to calculate the estimated outputs.

Examples

Estimate States Online Using Extended Kalman Filter

Estimate the states of a van der Pol oscillator using an extended Kalman filter algorithm and measured output data. The oscillator has two states and one output.

Create an extended Kalman filter object for the oscillator. Use previously written and saved state transition and measurement functions, `vdpStateFcn.m` and `vdpMeasurementFcn.m`. These functions describe a discrete-approximation to a van der Pol oscillator with the nonlinearity parameter μ equal to 1. The functions assume additive process and measurement noise in the system. Specify the initial state values for the two states as `[1;0]`. This is the guess for the state value at initial time k , based on knowledge of system outputs until time $k-1$, $\hat{x}[k|k-1]$.

```
obj = extendedKalmanFilter(@vdpStateFcn,@vdpMeasurementFcn,[1;0]);
```

Load the measured output data `y` from the oscillator. In this example, use simulated static data for illustration. The data is stored in the `vdp_data.mat` file.

```
load vdp_data.mat y
```

Specify the process noise and measurement noise covariances of the oscillator.

```
obj.ProcessNoise = 0.01;
obj.MeasurementNoise = 0.16;
```

Initialize arrays to capture results of the estimation.

```
residBuf = [];
xcorBuf = [];
xpredBuf = [];
```

Implement the extended Kalman filter algorithm to estimate the states of the oscillator by using the `correct` and `predict` commands. You first correct $\hat{x}[k|k-1]$ using measurements at time k to get $\hat{x}[k|k]$. Then, you predict the state value at the next time step $\hat{x}[k+1|k]$ using $\hat{x}[k|k]$, the state estimate at time step k that is estimated using measurements until time k .

To simulate real-time data measurements, use the measured data one time step at a time. Compute the residual between the predicted and actual measurement to assess how well the filter is performing and converging. Computing the residual is an optional step. When you use `residual`, place the command immediately before the `correct` command. If the prediction matches the measurement, the residual is zero.

After you perform the real-time commands for the time step, buffer the results so that you can plot them after the run is complete.

```
for k = 1:size(y)
    [Residual,ResidualCovariance] = residual(obj,y(k));
```

```

[CorrectedState,CorrectedStateCovariance] = correct(obj,y(k));
[PredictedState,PredictedStateCovariance] = predict(obj);

    residBuf(k,:) = Residual;
    xcorBuf(k,:) = CorrectedState';
    xpredBuf(k,:) = PredictedState';

end

```

When you use the `correct` command, `obj.State` and `obj.StateCovariance` are updated with the corrected state and state estimation error covariance values for time step `k`, `CorrectedState` and `CorrectedStateCovariance`. When you use the `predict` command, `obj.State` and `obj.StateCovariance` are updated with the predicted values for time step `k+1`, `PredictedState` and `PredictedStateCovariance`. When you use the `residual` command, you do not modify any `obj` properties.

In this example, you used `correct` before `predict` because the initial state value was $\hat{x}[k|k-1]$, a guess for the state value at initial time `k` based on system outputs until time `k-1`. If your initial state value is $\hat{x}[k-1|k-1]$, the value at previous time `k-1` based on measurements until `k-1`, then use the `predict` command first. For more information about the order of using `predict` and `correct`, see “Using `predict` and `correct` Commands” on page 2-179.

Plot the estimated states, using the postcorrection values.

```

plot(xcorBuf(:,1), xcorBuf(:,2))
title('Estimated States')

```

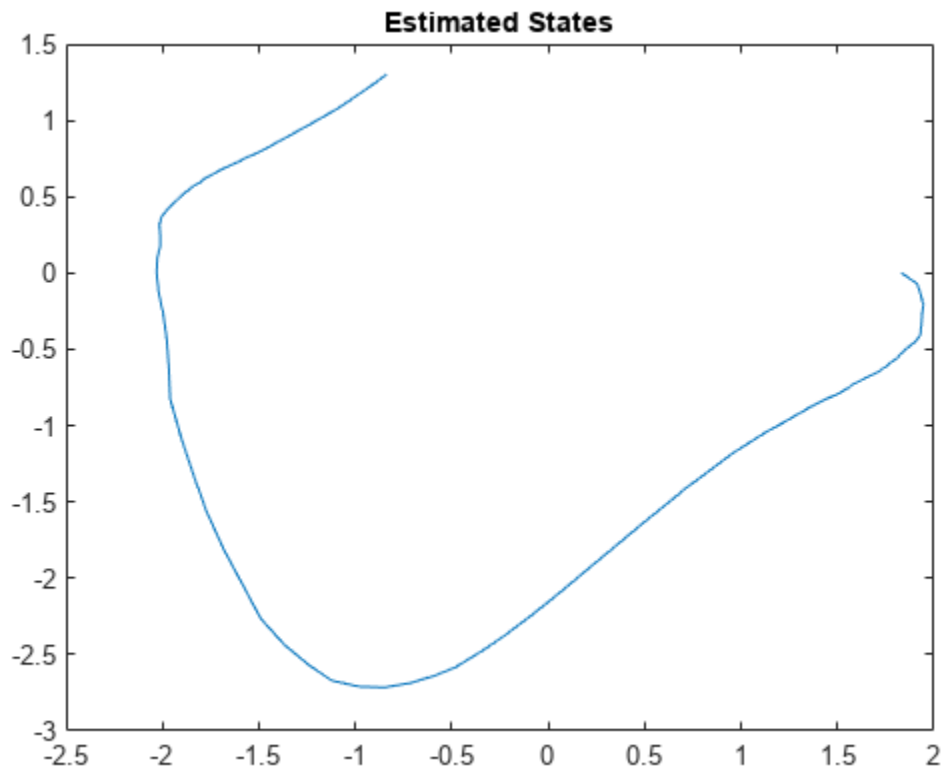

Plot the actual measurement, the corrected estimated measurement, and the residual. For the measurement function in `vdpMeasurementFcn`, the measurement is the first state.

```
M = [y,xcorBuf(:,1),residBuf];
plot(M)
grid on
title('Actual and Estimated Measurements, Residual')
legend('Measured','Estimated','Residual')
```

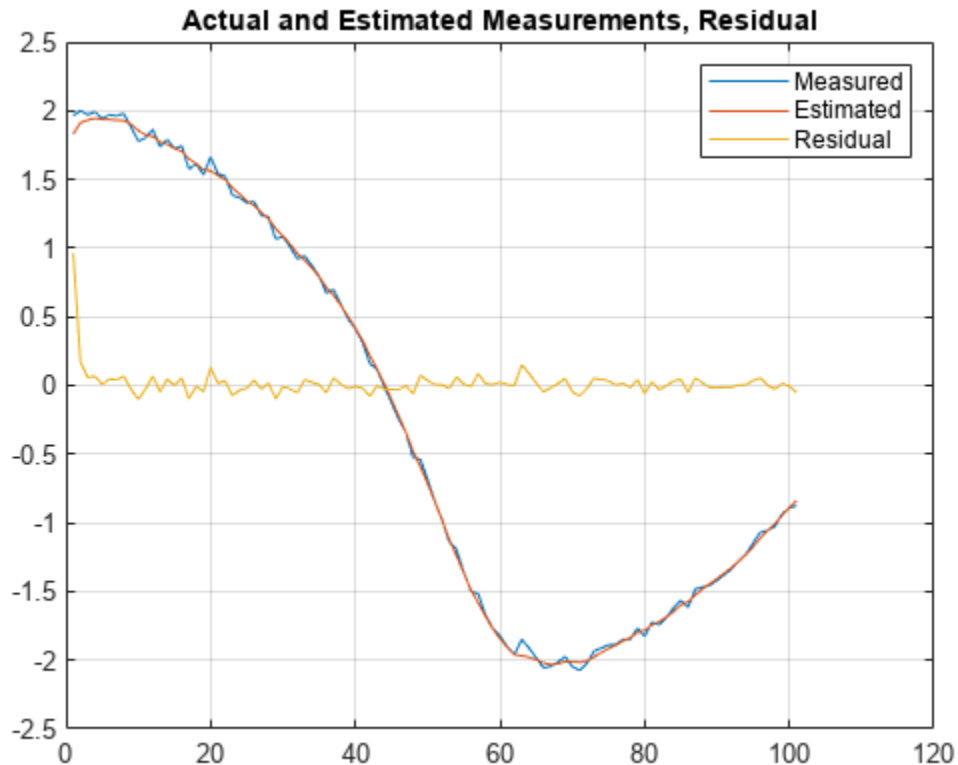

The estimate tracks the measurement closely. After the initial transient, the residual remains relatively small throughout the run.

Estimate States Online using Particle Filter

Load the van der Pol ODE data, and specify the sample time.

`vdpODEdata.mat` contains a simulation of the van der Pol ODE with nonlinearity parameter $\mu=1$, using `ode45`, with initial conditions $[2;0]$. The true state was extracted with sample time $dt = 0.05$.

```
addpath(fullfile(matlabroot,'examples','control','main')) % add example data
```

```
load ('vdpODEdata.mat','xTrue','dt')
tSpan = 0:dt:5;
```

Get the measurements. For this example, a sensor measures the first state with a Gaussian noise with standard deviation 0.04 .

```
sqrR = 0.04;  
yMeas = xTrue(:,1) + sqrR*randn(numel(tSpan),1);
```

Create a particle filter, and set the state transition and measurement likelihood functions.

```
myPF = particleFilter(@vdpParticleFilterStateFcn,@vdpMeasurementLikelihoodFcn);
```

Initialize the particle filter at state $[2; 0]$ with unit covariance, and use 1000 particles.

```
initialize(myPF,1000,[2;0],eye(2));
```

Pick the mean state estimation and systematic resampling methods.

```
myPF.StateEstimationMethod = 'mean';  
myPF.ResamplingMethod = 'systematic';
```

Estimate the states using the correct and predict commands, and store the estimated states.

```
xEst = zeros(size(xTrue));  
for k=1:size(xTrue,1)  
    xEst(k,:) = correct(myPF,yMeas(k));  
    predict(myPF);  
end
```

Plot the results, and compare the estimated and true states.

```
figure(1)  
plot(xTrue(:,1),xTrue(:,2),'x',xEst(:,1),xEst(:,2),'ro')  
legend('True','Estimated')
```

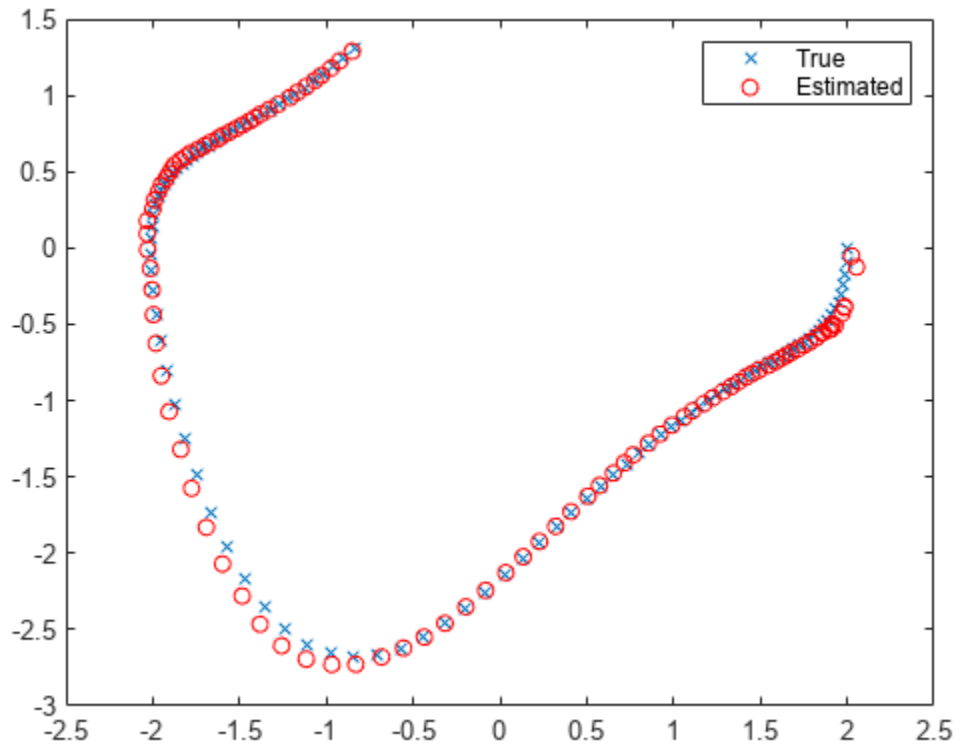

```
rmpath(fullfile(matlabroot, 'examples', 'control', 'main')) % remove example data
```

Specify State Transition and Measurement Functions with Additional Inputs

Consider a nonlinear system with input u whose state x and measurement y evolve according to the following state transition and measurement equations:

$$x[k] = \sqrt{x[k-1] + u[k-1]} + w[k-1]$$

$$y[k] = x[k] + 2 * u[k] + v[k]^2$$

The process noise w of the system is additive while the measurement noise v is nonadditive.

Create the state transition function and measurement function for the system. Specify the functions with an additional input u .

```
f = @(x,u)(sqrt(x+u));  
h = @(x,v,u)(x+2*u+v^2);
```

f and h are function handles to the anonymous functions that store the state transition and measurement functions, respectively. In the measurement function, because the measurement noise is nonadditive, v is also specified as an input. Note that v is specified as an input before the additional input u .

Create an extended Kalman filter object for estimating the state of the nonlinear system using the specified functions. Specify the initial value of the state as 1 and the measurement noise as nonadditive.

```
obj = extendedKalmanFilter(f,h,1,'HasAdditiveMeasurementNoise',false);
```

Specify the measurement noise covariance.

```
obj.MeasurementNoise = 0.01;
```

You can now estimate the state of the system using the `predict` and `correct` commands. You pass the values of `u` to `predict` and `correct`, which in turn pass them to the state transition and measurement functions, respectively.

Correct the state estimate with measurement $y[k]=0.8$ and input $u[k]=0.2$ at time step k .

```
correct(obj,0.8,0.2)
```

Predict the state at the next time step, given $u[k]=0.2$.

```
predict(obj,0.2)
```

Retrieve the error, or *residual*, between the prediction and the measurement.

```
[Residual, ResidualCovariance] = residual(obj,0.8,0.2);
```

Input Arguments

obj — Extended or unscented Kalman filter, or particle filter object

`extendedKalmanFilter` object | `unscentedKalmanFilter` object | `particleFilter` object

Extended or unscented Kalman filter, or particle filter object for online state estimation, created using one of the following commands:

- `extendedKalmanFilter` — Uses the extended Kalman filter algorithm.
- `unscentedKalmanFilter` — Uses the unscented Kalman filter algorithm.
- `particleFilter` — Uses the particle filter algorithm.

y — Measured system output

vector

Measured system output at the current time step, specified as an N -element vector, where N is the number of measurements.

Um1, ..., Umn — Additional input arguments to measurement function

input arguments of any type

Additional input arguments to the measurement function of the system, specified as input arguments of any type. The measurement function, h , is specified in the `MeasurementFcn` or `MeasurementLikelihoodFcn` property of `obj`. If the function requires input arguments in addition to the state and measurement noise values, you specify these inputs in the `correct` command syntax. `correct` command passes these inputs to the measurement or the measurement likelihood function to calculate estimated outputs. You can specify multiple arguments.

For example, suppose that your measurement or measurement likelihood function calculates the estimated system output y using system inputs u and current time k , in addition to the state x :

$$y(k) = h(x(k), u(k), k)$$

Then when you perform online state estimation at time step k , specify these additional inputs in the `correct` command syntax:

```
[CorrectedState,CorrectedStateCovariance] = correct(obj,y,u(k),k);
```

Output Arguments

CorrectedState — Corrected state estimate

vector

Corrected state estimate, returned as a vector of size M , where M is the number of states of the system. If you specify the initial states of `obj` as a column vector then M is returned as a column vector, otherwise M is returned as a row vector.

For information about how to specify the initial states of the object, see the `extendedKalmanFilter`, `unscentedKalmanFilter` and `particleFilter` reference pages.

CorrectedStateCovariance — Corrected state estimation error covariance

matrix

Corrected state estimation error covariance, returned as an M -by- M matrix, where M is the number of states of the system.

More About

Using `predict` and `correct` Commands

After you have created an extended or unscented Kalman filter, or particle filter object, `obj`, to implement the estimation algorithms, use the `correct` and `predict` commands together.

At time step k , `correct` command returns the corrected value of states and state estimation error covariance using measured system outputs $y[k]$ at the same time step. If your measurement function has additional input arguments U_m , you specify these as inputs to the `correct` command. The command passes these values to the measurement function.

```
[CorrectedState,CorrectedCovariance] = correct(obj,y,Um)
```

The `correct` command updates the `State` and `StateCovariance` properties of the object with the estimated values, `CorrectedState` and `CorrectedCovariance`.

The `predict` command returns the prediction of state and state estimation error covariance at the next time step. If your state transition function has additional input arguments U_s , you specify these as inputs to the `predict` command. The command passes these values to the state transition function.

```
[PredictedState,PredictedCovariance] = predict(obj,Us)
```

The `predict` command updates the `State` and `StateCovariance` properties of the object with the predicted values, `PredictedState` and `PredictedCovariance`.

If the current output measurement exists at a given time step, you can use `correct` and `predict`. If the measurement is missing, you can only use `predict`. For details about how these commands implement the algorithms, see “Extended and Unscented Kalman Filter Algorithms for Online State Estimation”.

The order in which you implement the commands depends on the availability of measured data y , U_s , and U_m for your system:

- `correct` then `predict` — Assume that at time step k , the value of `obj.State` is $\hat{x}[k|k-1]$. This value is the state of the system at time k , estimated using measured outputs until time $k-1$. You also have the measured output $y[k]$ and inputs $U_s[k]$ and $U_m[k]$ at the same time step.

Then you first execute the `correct` command with measured system data $y[k]$ and additional inputs $U_m[k]$. The command updates the value of `obj.State` to be $\hat{x}[k|k]$, the state estimate for time k , estimated using measured outputs up to time k . When you then execute the `predict` command with input $U_s[k]$, `obj.State` now stores $\hat{x}[k+1|k]$. The algorithm uses this state value as an input to the `correct` command in the next time step.

- `predict` then `correct` — Assume that at time step k , the value of `obj.State` is $\hat{x}[k-1|k-1]$. You also have the measured output $y[k]$ and input $U_m[k]$ at the same time step but you have $U_s[k-1]$ from the previous time step.

Then you first execute the `predict` command with input $U_s[k-1]$. The command updates the value of `obj.State` to $\hat{x}[k|k-1]$. When you then execute the `correct` command with input arguments $y[k]$ and $U_m[k]$, `obj.State` is updated with $\hat{x}[k|k]$. The algorithm uses this state value as an input to the `predict` command in the next time step.

Thus, while in both cases the state estimate for time k , $\hat{x}[k|k]$ is the same, if at time k you do not have access to the current state transition function inputs $U_s[k]$, and instead have $U_s[k-1]$, then use `predict` first and then `correct`.

For an example of estimating states using the `predict` and `correct` commands, see “Estimate States Online Using Extended Kalman Filter” on page 2-173 or “Estimate States Online using Particle Filter” on page 2-1031.

Version History

Introduced in R2016b

See Also

`predict` | `clone` | `extendedKalmanFilter` | `unscentedKalmanFilter` | `particleFilter` | `initialize` | `residual`

Topics

“Nonlinear State Estimation Using Unscented Kalman Filter and Particle Filter”

“Generate Code for Online State Estimation in MATLAB”

“Extended and Unscented Kalman Filter Algorithms for Online State Estimation”

covar

Output and state covariance of system driven by white noise

Syntax

```
P = covar(sys,W)
[P,Q] = covar(sys,W)
```

Description

`covar` calculates the stationary covariance of the output y of an LTI model `sys` driven by Gaussian white noise inputs w . This function handles both continuous- and discrete-time cases.

`P = covar(sys,W)` returns the steady-state output response covariance

$$P = E(yy^T)$$

given the noise intensity

$$E(w(t)w(\tau)^T) = W\delta(t - \tau) \quad (\text{continuous time})$$

$$E(w[k]w[l]^T) = W\delta_{kl} \quad (\text{discrete time})$$

`[P,Q] = covar(sys,W)` also returns the steady-state state covariance

$$Q = E(xx^T)$$

when `sys` is a state-space model (otherwise `Q` is set to []).

When applied to an N -dimensional LTI array `sys`, `covar` returns multidimensional arrays P , Q such that

$P(:, :, i1, \dots, iN)$ and $Q(:, :, i1, \dots, iN)$ are the covariance matrices for the model `sys(:, :, i1, \dots, iN)`.

Examples

Compute the output response covariance of the discrete SISO system

$$H(z) = \frac{2z + 1}{z^2 + 0.2z + 0.5}, \quad T_s = 0.1$$

due to Gaussian white noise of intensity $W = 5$. Type

```
sys = tf([2 1],[1 0.2 0.5],0.1);
p = covar(sys,5)
```

These commands produce the following result.

```
p =
    30.3167
```

You can compare this output of `covar` to simulation results.

```
randn('seed',0)
w = sqrt(5)*randn(1,1000); % 1000 samples

% Simulate response to w with LSIM:
y = lsim(sys,w);

% Compute covariance of y values
psim = sum(y .* y)/length(w);
```

This yields

```
psim =
    32.6269
```

The two covariance values `p` and `psim` do not agree perfectly due to the finite simulation horizon.

Algorithms

Transfer functions and zero-pole-gain models are first converted to state space with `ss`.

For continuous-time state-space models

$$\begin{aligned}\dot{x} &= Ax + Bw \\ y &= Cx + Dw,\end{aligned}$$

the steady-state state covariance Q is obtained by solving the Lyapunov equation

$$AQ + QA^T + BWB^T = 0.$$

In discrete time, the state covariance Q solves the discrete Lyapunov equation

$$AQA^T - Q + BWB^T = 0.$$

In both continuous and discrete time, the output response covariance is given by $P = CQC^T + DWD^T$. For unstable systems, P and Q are infinite. For continuous-time systems with nonzero feedthrough, `covar` returns `Inf` for the output covariance P .

Version History

Introduced before R2006a

References

[1] Bryson, A.E. and Y.C. Ho, *Applied Optimal Control*, Hemisphere Publishing, 1975, pp. 458-459.

See Also

`dlyap` | `lyap`

Create Plot

Interactively create linear analysis response plots in the Live Editor

Description

The **Create Plot** Live Editor task lets you interactively create time-domain and frequency-domain analysis plots for dynamic system models in your MATLAB workspace. This page describes a subset of the functionality available in the **Create Plot** live task — the subset available when you select **Control System Plots** in the **Category** menu. For more information about the task in general, see the **Create Plot** Live Editor task reference page.

Supported plots

The **Create Plot** Live Editor task supports the following linear analysis response plots:

- `bodeplot`
- `sigmaplot`
- `nyquistplot`
- `nicholsplot`
- `stepplot`
- `impulseplot`
- `rlocusplot`
- `pzplot`
- `iopzplot`
- `hsvplot`

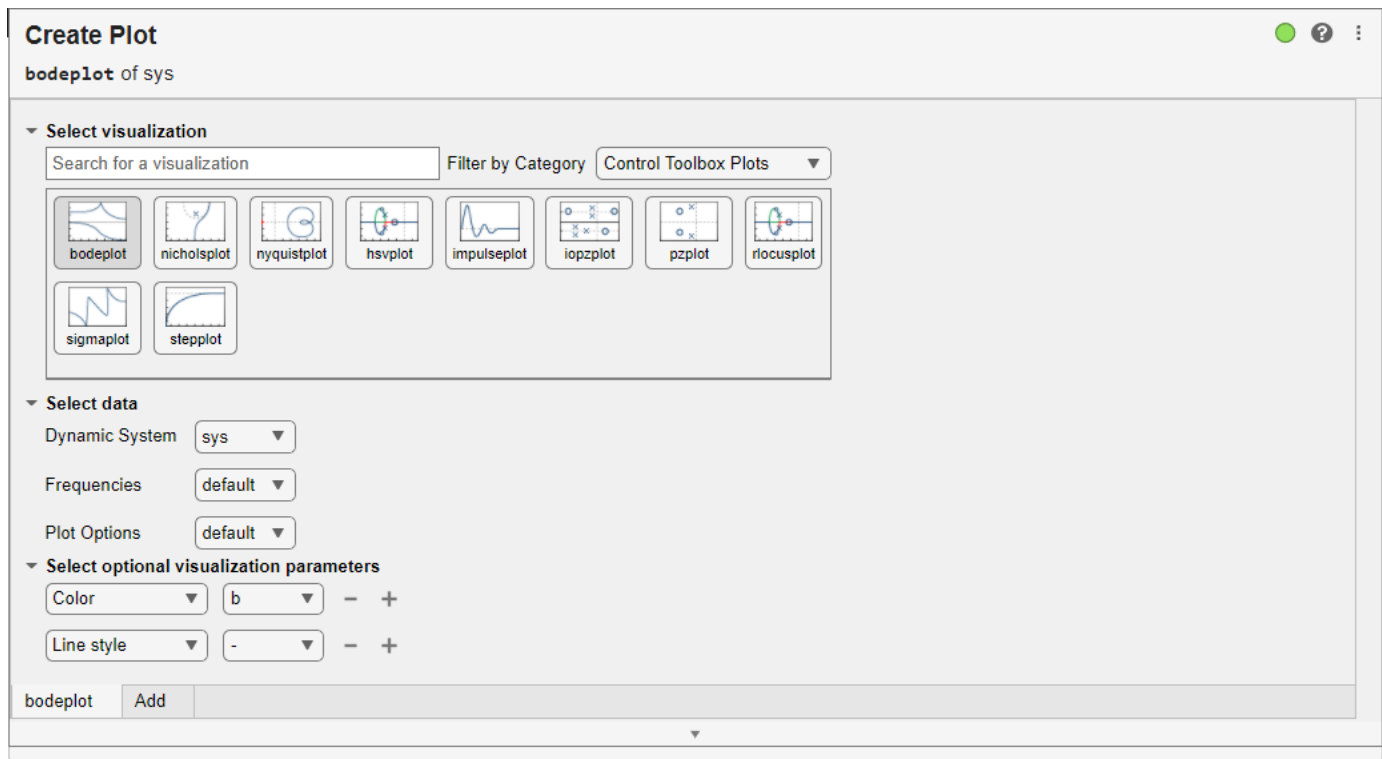

Open the Create Plot

To add the **Create Plot** task to a live script in the MATLAB Live Editor:

- On the **Live Editor** tab, click **Task** and select the **Create Plot** icon .
- In a code block in the live script, type a relevant keyword, such as `bode`, `step`, `pzplot`, or `impulse`. Select **Create Plot** from the suggested command completions. When you add the task using this method, then MATLAB automatically selects the corresponding chart type in the **Select visualization** section of the task.

Examples

Interactively Create Bode Plot in the Live Editor

Use the **Create Plot** task in the Live Editor to interactively create and visualize different linear analysis plots. You can also use an options object from your MATLAB® workspace to customize your plot. Open this example to see a preconfigured script containing the **Create Plot** task to create a Bode plot.

For this example, consider the following SISO state-space model:

$$A = \begin{bmatrix} -1.5 & -2 \\ 1 & 0 \end{bmatrix} \quad B = \begin{bmatrix} 0.5 \\ 0 \end{bmatrix} \quad C = [0 \ 1] \quad D = 0$$

Create the SISO state-space model defined by the following state-space matrices:

```
A = [-1.5, -2; 1, 0];
B = [0.5; 0];
C = [0, 1];
D = 0;
sys = ss(A,B,C,D);
```

To create a Bode plot of `sys`, open the **Create Plot** task in the Live Editor. On the **Live Editor** tab, select **Task > Create Plot**. In the task, select **Controls Toolbox Plots** from the **Filter by Category** dropdown menu. You can also directly search for the plot type by typing in the plot name in the **Select visualization** field.

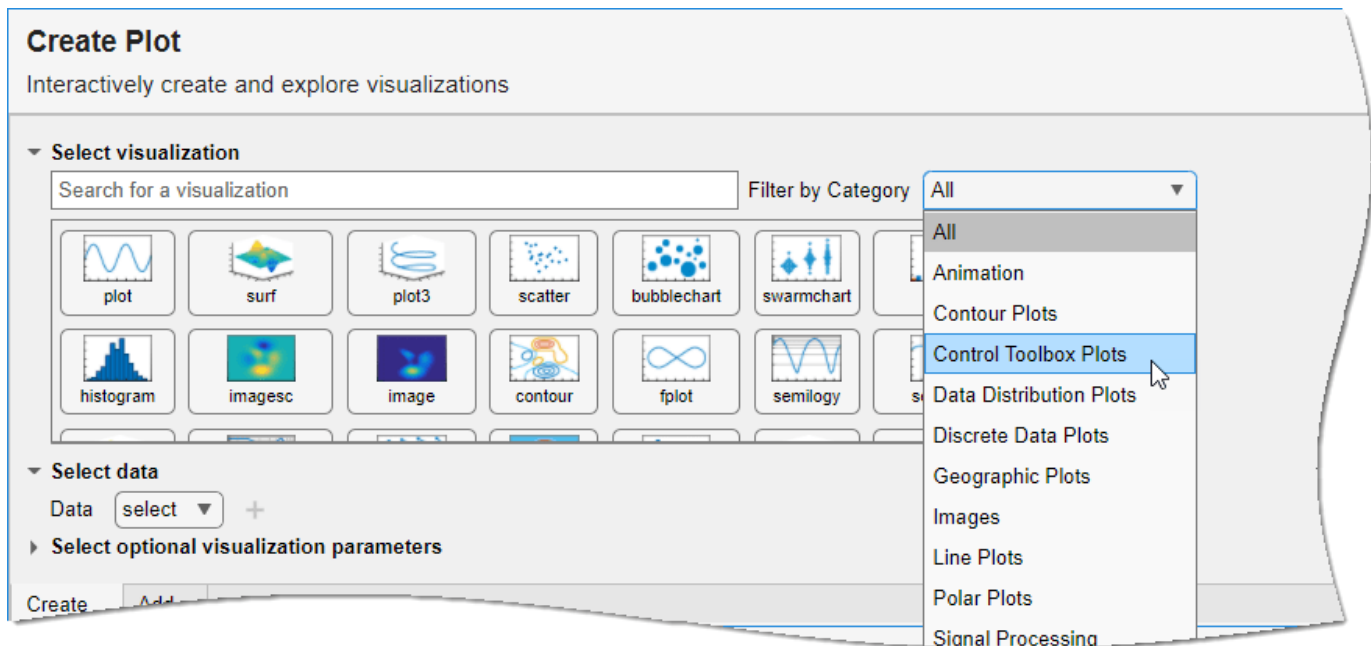

Next, select **bodeplot** from the available plots. If you do not have a supported model type in your MATLAB workspace, then the respective plot type will not be available.

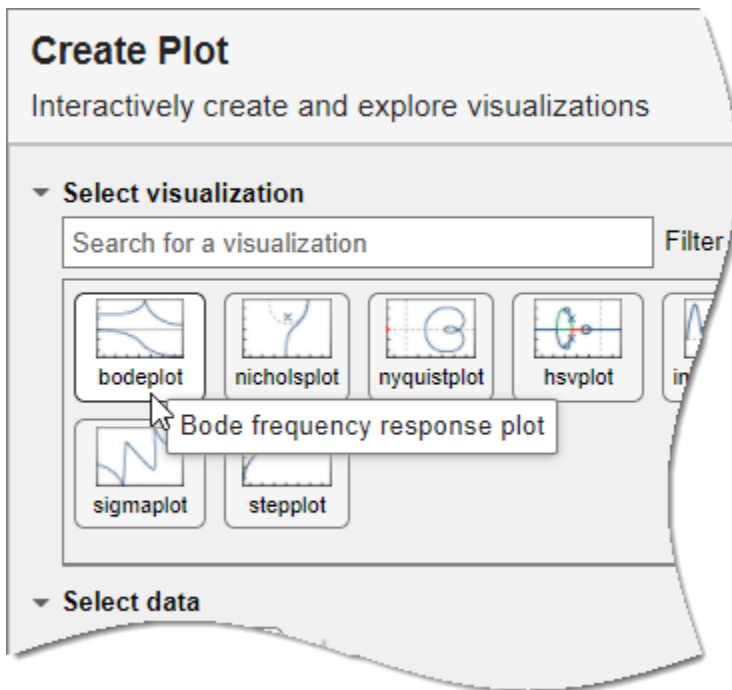

Use the **Dynamic System** dropdown menu to pick the appropriate model from your MATLAB workspace. You can use the **Frequencies** dropdown menu to specify a vector of frequencies. You can also customize your plot by using a predefined options object. For more information, see `bodeplot`.

For this example, pick `sys` and leave the other options as default.

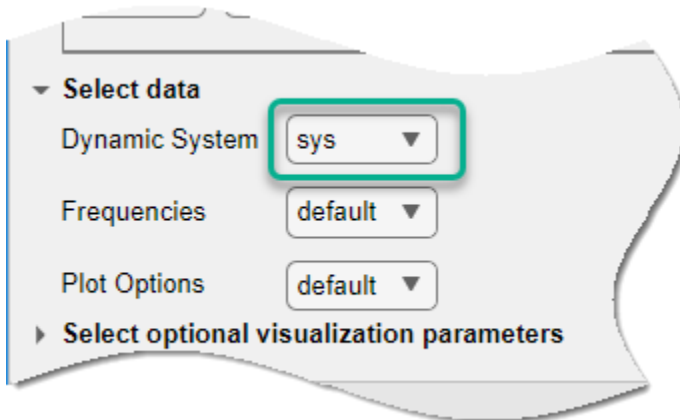

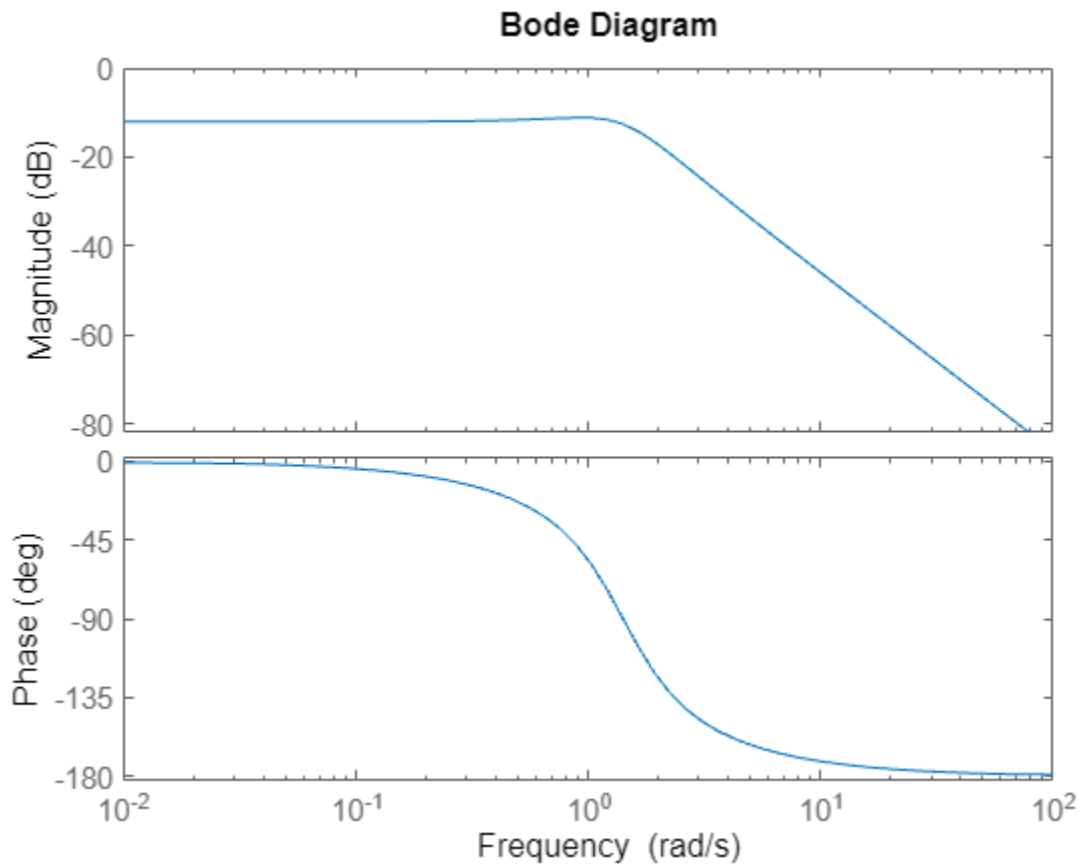

You can also select the color, line style and marker symbol for the plot using the **Select optional visualization parameters** menu. You can click **+** to add more visualization parameters. For this example, change the line color to green.

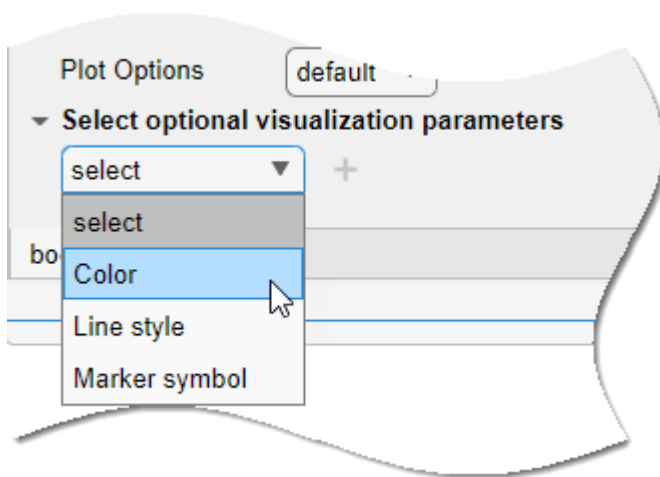

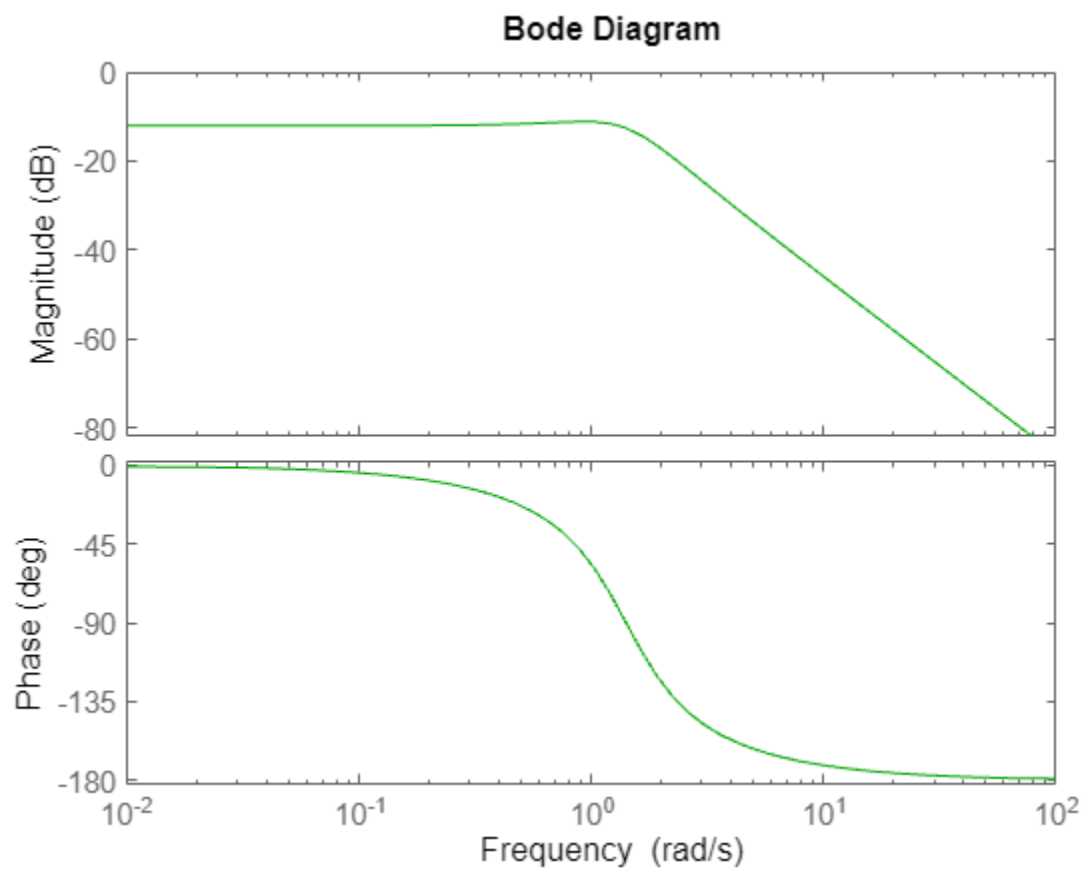
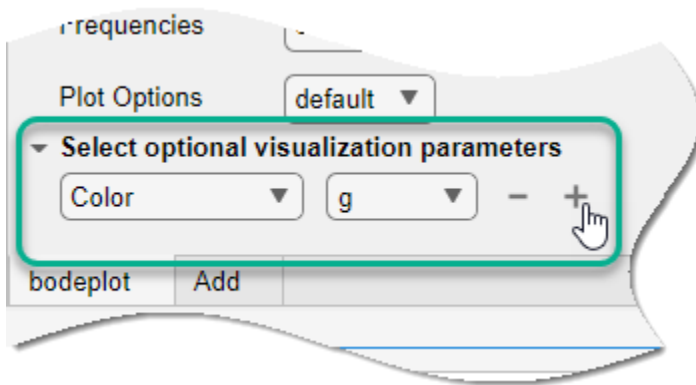

To see the code that this task generates, expand the task display by clicking  at the bottom of the task parameter area.

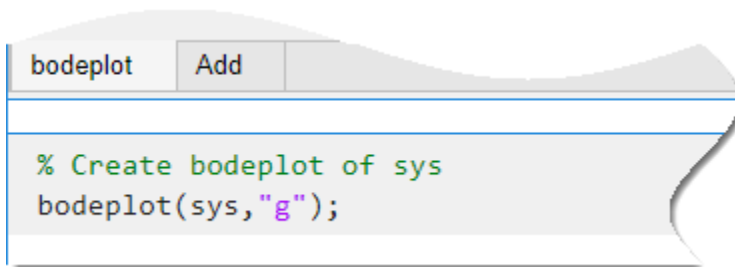

You can also overlay multiple visualizations on the same plot axis. For more information and examples, see the Create Plot task reference page.

Parameters

Dynamic System — Model to create the linear analysis response plot

dynamic system model | model array

Choose the dynamic system model or model array to create the linear analysis response plot. Dynamic systems that you can use include:

- Continuous-time or discrete-time numeric LTI models, such as `tf`, `zpk`, or `ss` models.
- Sparse state-space models, such as `sparss` or `mechss` models.
- Generalized or uncertain LTI models such as `genss` or `uss` models. (Using uncertain models requires Robust Control Toolbox software.)
 - For tunable control design blocks, the task evaluates the model at its current value to plot the response data.
 - For uncertain control design blocks, the task plots the nominal value and random samples of the model.
- Frequency-response data models such as `frd` models to plot the Bode, sigma, Nyquist or Nichols response. For such models, the task plots the response at frequencies defined in the model.
- Identified LTI models, such as `idtf`, `idss`, or `idproc` models. (Using identified models requires System Identification Toolbox software.)

Note

- You can only use a single model to plot Hankel singular values. For all other response plots, the task plots the responses of all models in the array on the same axes when you have an array of dynamic system models.
-

Plot Options — Plot options set for customization

BodeOptions object | SigmaOptions object | NicholsOptions object | NyquistOptions object | TimeOptions object | PZOptions object | HSVOptions object

Create and choose the correct options set based on the plot type as follows:

Plot Type	Options Object	Creation Function
bodeplot	BodeOptions object	bodeoptions
sigmaplot	SigmaOptions object	sigmaoptions
nyquistplot	NyquistOptions object	nyquistoptions
nicholsplot	NicholsOptions object	nicholsoptions
stepplot	TimeOptions object	timeoptions
impulseplot	TimeOptions object	timeoptions
rlocusplot	PZOptions object	pzoptions
pzplot	PZOptions object	pzoptions
iopzplot	PZOptions object	pzoptions
hsvplot	HSVOptions object	hsvoptions

Version History

Introduced in R2022b

See Also

Functions

bodeplot | stepplot | rlocusplot | impulseplot | nicholsplot | nyquistplot | pzplot | hsvplot | iopzplot | sigmaplot | bodeoptions | nicholsoptions | hsvoptions | nyquistoptions | pzoptions | sigmaoptions | timeoptions

Live Editor Tasks

Create Plot

ctranspose, '

Conjugate dynamic system model

Syntax

$H = \text{ctranspose}(G)$

Description

$H = \text{ctranspose}(G)$ computes the conjugate of the dynamic system model or static model G . The `ctranspose` command is equivalent to the `'` operator.

If G is a dynamic system model poles P and zeros Z , then the conjugate system $H = \text{ctranspose}(G) = G'$ has the following properties.

- In continuous time, the poles of H are $-P$ and the zeros of H are $-Z$. The frequency response of H is the Hermitian transpose of the frequency response of G :

$$H(j\omega) = G(j\omega)^H.$$

- In discrete time with sample time T_s , the poles of H are $1/P$ and the zeros of H are $1/Z$. The frequency response of H is the Hermitian transpose of the frequency response of G :

$$H(z) = G(z)^H,$$

where $z = e^{i\omega T_s}$.

If G is a static model, then H is the complex-conjugate transpose of the matrix.

Examples

Conjugate of Dynamic System Model

Compute the conjugate of a one-input, two-output transfer function model.

```
s = tf('s');
G1 = (s + 1)/(s^2 + 2*s + 1);
G2 = 1/s;
G = [G1;G2]
```

G =

From input to output...

```
      s + 1
1:  -----
      s^2 + 2 s + 1

      1
2:  -
      s
```

Continuous-time transfer function.

The conjugate has two outputs and one input, and takes s to $-s$.

```
H = ctranspose(G)
```

```
H =
```

```
From input 1 to output:
```

```
  -s + 1  
-----  
s^2 - 2 s + 1
```

```
From input 2 to output:
```

```
  -1  
  --  
  s
```

Continuous-time transfer function.

Using the ' operator yields the same result as ctranspose.

```
H = G'
```

```
H =
```

```
From input 1 to output:
```

```
  -s + 1  
-----  
s^2 - 2 s + 1
```

```
From input 2 to output:
```

```
  -1  
  --  
  s
```

Continuous-time transfer function.

Hermitian Transpose of Frequency Response

Obtain the frequency response and the Hermitian transpose of the frequency response of a transfer function at one frequency.

```
G = [tf(1,[1 0]);tf([1 0],[1 1])];
```

```
w = 3;
```

```
resp = freqresp(G,w)
```

```
resp = 2x1 complex
```

```
  0.0000 - 0.3333i  
  0.9000 + 0.3000i
```

The Hermitian transpose of the frequency response is the frequency response of the conjugate of G.

```
respH = freqresp(G',w)
```

```
respH = 1x2 complex
```

```
  0.0000 + 0.3333i   0.9000 - 0.3000i
```

Input Arguments

G — Input system

dynamic system model | static model

Input system, specified as a dynamic system model or static model such as a `tf`, `zpk`, or `ss` model. `G` can be a generalized model provided that its control design blocks are scalar and nondynamic, such as a scalar `ureal` parameter.

Output Arguments

H — Conjugate model

dynamic system model | static model

Conjugate model of `G`, returned as a dynamic system model or static model of the same type as `G`.

Version History

Introduced before R2006a

See Also

`inv`

Topics

“Catalog of Model Interconnections”

“Types of Model Objects”

ctrb

Controllability of state-space model

Syntax

```
Co = ctrb(A,B)
Co = ctrb(sys)
```

Description

A dynamic system is said to be *controllable* if it is possible to apply control signals that drive the system to any state within a finite amount of time. This characteristic is also called *reachability*. `ctrb` computes a controllability matrix from state matrices or from a state-space model. You can use this matrix to determine controllability.

For instance, consider a continuous-time state-space model with N_x states, N_y outputs, and N_u inputs:

$$\begin{aligned}\dot{x} &= Ax + Bu \\ y &= Cx + Du\end{aligned}$$

Here, x , u and y represent the states, inputs and outputs respectively, while A , B , C and D are the state-space matrices with the following sizes:

- A is an N_x -by- N_x real-valued or complex-valued matrix.
- B is an N_x -by- N_u real-valued or complex-valued matrix.
- C is an N_y -by- N_x real-valued or complex-valued matrix.
- D is an N_y -by- N_u real-valued or complex-valued matrix.

The system is controllable if the controllability matrix generated by `ctrb` $Co = [B \ AB \ A^2B \ \dots \ A^{n-1}B]$ has full rank, that is, the rank is equal to the number of states in the state-space model. The controllability matrix Co has N_x rows and $N_x N_u$ columns. For an example, see “Controllability of SISO State-Space Model” on page 2-195.

`Co = ctrb(A,B)` returns the controllability matrix Co using the state matrix A and input-to-state matrix B . The system is controllable if Co has full rank, that is, the rank of Co is equal to the number of states.

`Co = ctrb(sys)` returns the controllability matrix of the state space model `sys`. This syntax is equivalent to:

```
Co = ctrb(sys.A,sys.B);
```

Examples

Check System Controllability

Define A and B matrices.

```
A = [1 1;
      4 -2];
B = [1 -1;
      1 -1];
```

Compute controllability matrix.

```
Co = ctrb(A,B);
```

Determine the number of uncontrollable states.

```
unco = length(A) - rank(Co)
```

```
unco = 1
```

The uncontrollable state indicates that Co does not have full rank 2. Therefore the system is not controllable.

Controllability of SISO State-Space Model

For this example, consider the following SISO state-space model with 2 states:

$$A = \begin{bmatrix} -1.5 & -2 \\ 1 & 0 \end{bmatrix} \quad B = \begin{bmatrix} 0.5 \\ 0 \end{bmatrix} \quad C = [0 \ 1] \quad D = 1$$

Create the SISO state-space model defined by the following state-space matrices:

```
A = [-1.5, -2; 1, 0];
B = [0.5; 0];
C = [0, 1];
D = 1;
sys = ss(A,B,C,D);
```

Compute the controllability matrix and find the rank.

```
Co = ctrb(sys)
```

```
Co = 2x2
```

```
    0.5000    -0.7500
         0     0.5000
```

The size of the controllability matrix depends on the size of the A and B matrices. For instance, if matrix A is an Nx-by-Nx matrix and matrix B is an Nx-by-Nu matrix, then the resultant matrix Co has Nx rows and Nxu columns. Here, Nx is the number of states and Nu is the number of inputs.

```
rank(Co)
```

```
ans = 2
```

Since the rank of the controllability matrix Co is equal to the number of states, the system sys is controllable.

Alternatively, you can also use just the A and B matrices to find the controllability matrix.

```
Co = ctrb(sys.A,sys.B);  
rank(Co)
```

```
ans = 2
```

Input Arguments

A — State matrix

Nx-by-Nx matrix

State matrix, specified as an Nx-by-Nx matrix where, Nx is the number of states.

B — Input-to-state matrix

Nx-by-Nu matrix

Input-to-state matrix, specified as an Nx-by-Nu matrix where Nx is the number of states and Nu is the number of inputs.

sys — State-space model or model array

ss model object | genss model object | uss model object

State-space model or model array, specified as:

- A state-space (ss) model object, when the inputs A, B, C and D are numeric matrices or when converting from another model object type.
- A generalized state-space model (genss) object, when one or more of the matrices A, B, C and D includes tunable parameters, such as `realp` parameters or generalized matrices (`genmat`). The function uses the current values for tunable parameters.
- An uncertain state-space model (uss) object, when one or more of the inputs A, B, C and D includes uncertain matrices. The function uses the nominal values for uncertain parameters. Using uncertain models requires Robust Control Toolbox software.

Output Arguments

Co — Controllability matrix

array

Controllability matrix, returned as an array. When `sys` is:

- A single state-space model with Nx states and Nu inputs, then the resultant array `Co` has Nx rows and Nxu columns.
- An array of state-space models `sys(:, :, j1, ..., jN)`, then `Co` is an array with N+2 dimensions, that is, `Co(:, :, j1, ..., jN)`.

Version History

Introduced before R2006a

References

- [1] Paige, C. C. "Properties of Numerical Algorithms Related to Computing Controllability." *IEEE Transactions on Automatic Control*. Vol. 26, Number 1, 1981, pp. 130-138.

See Also

ctrbf | obsv

External Websites

Video - A Conceptual Approach to Controllability and Observability

ctrbf

Compute controllability staircase form

Syntax

```
[Abar,Bbar,Cbar,T,k] = ctrbf(A,B,C)
ctrbf(A,B,C,tol)
```

Description

If the controllability matrix of (A, B) has rank $r \leq n$, where n is the size of A , then there exists a similarity transformation such that

$$\bar{A} = TAT^T, \bar{B} = TB, \bar{C} = CT^T$$

where T is unitary, and the transformed system has a *staircase* form, in which the uncontrollable modes, if there are any, are in the upper left corner.

$$\bar{A} = \begin{bmatrix} A_{uc} & 0 \\ A_{21} & A_c \end{bmatrix}, \bar{B} = \begin{bmatrix} 0 \\ B_c \end{bmatrix}, \bar{C} = [C_{nc} C_c]$$

where (A_c, B_c) is controllable, all eigenvalues of A_{uc} are uncontrollable, and $C_c(sI - A_c)^{-1}B_c = C(sI - A)^{-1}B$.

`[Abar,Bbar,Cbar,T,k] = ctrbf(A,B,C)` decomposes the state-space system represented by A , B , and C into the controllability staircase form, $Abar$, $Bbar$, and $Cbar$, described above. T is the similarity transformation matrix and k is a vector of length n , where n is the order of the system represented by A . Each entry of k represents the number of controllable states factored out during each step of the transformation matrix calculation. The number of nonzero elements in k indicates how many iterations were necessary to calculate T , and $\text{sum}(k)$ is the number of states in A_c , the controllable portion of $Abar$.

`ctrbf(A,B,C,tol)` uses the tolerance `tol` when calculating the controllable/uncontrollable subspaces. When the tolerance is not specified, it defaults to $10*n*norm(A,1)*\text{eps}$.

Examples

Compute the controllability staircase form for

$$A = \begin{bmatrix} 1 & 1 \\ 4 & -2 \end{bmatrix}$$

$$B = \begin{bmatrix} 1 & -1 \\ 1 & -1 \end{bmatrix}$$

$$C = \begin{bmatrix} 1 & 0 \\ 0 & 1 \end{bmatrix}$$

and locate the uncontrollable mode.

```
[Abar, Bbar, Cbar, T, k]=ctrbf(A, B, C)
```

```
Abar =
  -3.0000      0
  -3.0000      2.0000
```

```
Bbar =
   0.0000    0.0000
   1.4142   -1.4142
```

```
Cbar =
  -0.7071    0.7071
   0.7071    0.7071
```

```
T =
  -0.7071    0.7071
   0.7071    0.7071
```

```
k =
     1     0
```

The decomposed system `Abar` shows an uncontrollable mode located at -3 and a controllable mode located at 2.

Algorithms

`ctrbf` implements the Staircase Algorithm of [1].

Version History

Introduced before R2006a

References

[1] Rosenbrock, M.M., *State-Space and Multivariable Theory*, John Wiley, 1970.

See Also

`ctrb` | `minreal`

ctrlpref

Set Control System Toolbox preferences

Syntax

`ctrlpref`

Description

`ctrlpref` opens a Graphical User Interface (GUI) which allows you to change the Control System Toolbox preferences. Preferences set in this GUI affect future plots only (existing plots are not altered).

Your preferences are stored to disk (in a system-dependent location) and will be automatically reloaded in future MATLAB sessions using the Control System Toolbox software.

Version History

Introduced in R2006a

See Also

Control System Designer | Linear System Analyzer

d2c

Convert model from discrete to continuous time

Syntax

```
sysc = d2c(sysd)
sysc = d2c(sysd,method)
sysc = d2c(sysd,opts)
[sysc,G] = d2c( ___ )
```

Description

`sysc = d2c(sysd)` converts a the discrete-time dynamic system model `sysd` to a continuous-time model using zero-order hold on the inputs.

`sysc = d2c(sysd,method)` specifies the conversion method.

`sysc = d2c(sysd,opts)` specifies conversion options for the discretization.

`[sysc,G] = d2c(___)`, where `sysd` is a state-space model, returns a matrix `G` that maps the states `xd[k]` of the discrete-time state-space model to the states `xc(t)` of `sysc`.

Examples

Convert Discrete-Time Transfer Function to Continuous Time

Create the following discrete-time transfer function:

$$H(z) = \frac{z - 1}{z^2 + z + 0.3}$$

```
H = tf([1 -1],[1 1 0.3],0.1);
```

The sample time of the model is $T_s = 0.1$ s.

Derive a continuous-time, zero-order-hold equivalent model.

```
Hc = d2c(H)
```

```
Hc =
```

$$\frac{121.7 s + 1.758e-12}{s^2 + 12.04 s + 776.7}$$

Continuous-time transfer function.

Discretize the resulting model, `Hc`, with the default zero-order hold method and sample time 0.1s to return the original discrete model, `H`.

```
c2d(Hc,0.1)
```

```
ans =
```

$$\frac{z - 1}{z^2 + z + 0.3}$$

```
Sample time: 0.1 seconds  
Discrete-time transfer function.
```

Use the Tustin approximation method to convert H to a continuous time model.

```
Hc2 = d2c(H, 'tustin');
```

Discretize the resulting model, Hc2, to get back the original discrete-time model, H.

```
c2d(Hc2,0.1, 'tustin');
```

Convert Identified Discrete-Time Transfer Function to Continuous Time

Estimate a discrete-time transfer function model, and convert it to a continuous-time model.

```
load iddata1  
sys1d = tfest(z1,2, 'Ts',0.1);  
sys1c = d2c(sys1d, 'zoh');
```

Estimate a continuous-time transfer function model.

```
sys2c = tfest(z1,2);
```

Compare the response of sys1c and the directly estimated continuous-time model, sys2c.

```
compare(z1,sys1c,sys2c)
```

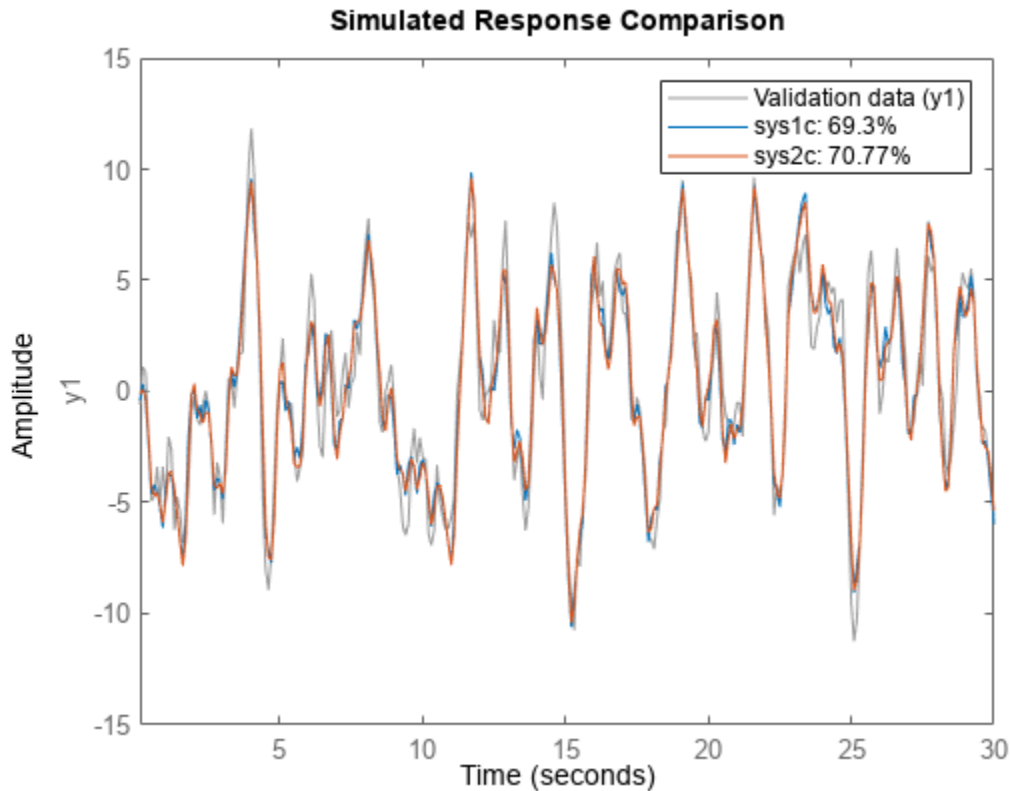

The two systems are almost identical.

Regenerate Covariance Information After Converting to Continuous-Time Model

Convert an identified discrete-time transfer function model to continuous-time.

```
load iddata1
sysd = tfest(z1,2,'Ts',0.1);
sysc = d2c(sysd,'zoh');
```

sys1c has no covariance information. The d2c operation leads to loss of covariance data of identified models.

Regenerate the covariance information using a zero iteration update with the same estimation command and estimation data.

```
opt = tfestOptions;
opt.SearchOptions.MaxIterations = 0;
sys1c = tfest(z1,sysc,opt);
```

Analyze the effect on frequency-response uncertainty.

```
h = bodeplot(sysd,sys1c);
showConfidence(h,3)
```

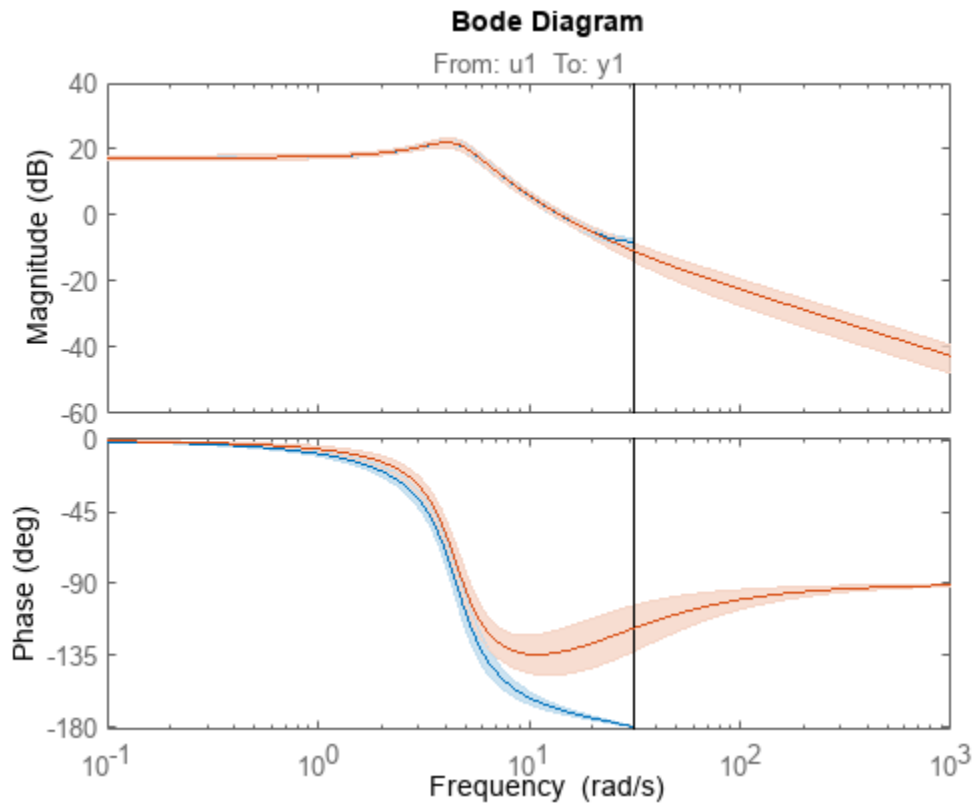

The uncertainties of `sys1c` and `sysd` are comparable up to the Nyquist frequency. However, `sys1c` exhibits large uncertainty in the frequency range for which the estimation data does not provide any information.

If you do not have access to the estimation data, use the `translatecov` command which is a Gauss-approximation formula based translation of covariance across model type conversion operations.

Input Arguments

`sysd` — Discrete-time dynamic system

dynamic system model

Discrete-time model, specified as a dynamic system model such as `tf`, `ss`, or `zpk`.

You cannot directly use an `idgrey` model whose `FunctionType` is 'd' with `d2c`. Convert the model into `idss` form first.

`method` — Discrete-to-continuous time conversion method

'zoh' (default) | 'foh' | 'tustin' | 'matched'

Discrete-to-continuous time conversion method, specified as one of the following values:

- 'zoh' — Zero-order hold on the inputs. Assumes that the control inputs are piecewise constant over the sampling period.

- 'foh' — Linear interpolation of the inputs (modified first-order hold). Assumes that the control inputs are piecewise linear over the sampling period.
- 'tustin' — Bilinear (Tustin) approximation to the derivative. To specify this method with frequency prewarping (formerly known as the 'prewarp' method), use the PrewarpFrequency option of d2cOptions.
- 'matched' — Zero-pole matching method (for SISO systems only). See [1].

For information about the algorithms for each d2c conversion method, see “Continuous-Discrete Conversion Methods”.

opts — Discrete-to-continuous time conversion options

d2cOptions object

Discrete-to-continuous time conversion options, created using d2cOptions. For example, specify the prewarp frequency or the conversion method as an option.

Output Arguments

sysc — Continuous-time model

dynamic system model

Continuous-time model, returned as a dynamic system model of the same type as the input system sysd.

When sysd is an identified (IDLTI) model, sysc:

- Includes both the measured and noise components of sysd. If the noise variance is λ in sysd, then the continuous-time model sysc has an indicated level of noise spectral density equal to $T_s \cdot \lambda$.
- Does not include the estimated parameter covariance of sysd. If you want to translate the covariance while converting the model, use translatecov.

G — Mapping of discrete-time states of state-space model to continuous-time states

matrix

Mapping of the states $x_d[k]$ of the state-space model sysd to the states $x_c(t)$ of sysc, returned as a matrix. The mapping of the states is as follows:

$$x_c(kT_s) = G \begin{bmatrix} x_d[k] \\ u[k] \end{bmatrix}.$$

Given an initial condition x_0 for sysd and an initial input $u_0 = u[0]$, the corresponding initial condition for sysc (assuming $u[k] = 0$ for $k < 0$) is:

$$x_c(0) = G \begin{bmatrix} x_0 \\ u_0 \end{bmatrix}.$$

Version History

Introduced before R2006a

References

- [1] Franklin, G.F., Powell,D.J., and Workman, M.L., *Digital Control of Dynamic Systems* (3rd Edition), Prentice Hall, 1997.
- [2] Kollár, I., G.F. Franklin, and R. Pintelon, "On the Equivalence of z-domain and s-domain Models in System Identification," *Proceedings of the IEEE Instrumentation and Measurement Technology Conference*, Brussels, Belgium, June, 1996, Vol. 1, pp. 14-19.

See Also

d2cOptions | c2d | translatecov | logm | Convert Model Rate

Topics

"Dynamic System Models"

"Convert Discrete-Time System to Continuous Time"

"Continuous-Discrete Conversion Methods"

d2cOptions

Create option set for discrete- to continuous-time conversions

Syntax

```
opts = d2cOptions
opts = d2cOptions(Name,Value)
```

Description

`opts = d2cOptions` returns the default options for `d2c`.

`opts = d2cOptions(Name,Value)` creates an option set with the options specified by one or more `Name,Value` pair arguments.

Input Arguments

Name-Value Pair Arguments

method

Discretization method, specified as one of the following values:

'zoh'	Zero-order hold, where <code>d2c</code> assumes that the control inputs are piecewise constant over the sample time <code>Ts</code> .
'foh'	Linear interpolation of the inputs (modified first-order hold). Assumes that the control inputs are piecewise linear over the sampling period.
'tustin'	Bilinear (Tustin) approximation. By default, <code>d2c</code> converts with no prewarp. To include prewarp, use the <code>PrewarpFrequency</code> option.
'matched'	Zero-pole matching method. (See [1] on page 2-208, p. 224.)

For information about the algorithms for each `d2c` conversion method, see “Continuous-Discrete Conversion Methods”.

Default: 'zoh'

PrewarpFrequency

Prewarp frequency for 'tustin' method, specified in `rad/TimeUnit`, where `TimeUnit` is the time units, specified in the `TimeUnit` property, of the discrete-time system. Specify the prewarp frequency as a positive scalar value. A value of 0 corresponds to the 'tustin' method without prewarp.

Default: 0

Output Arguments

opts — Option set for `d2c`
`d2cOptions` option set

Option set for `d2c`, returned as an `d2cOptions` option set.

Examples

Specify Model Discretization Method

Consider the following discrete-time transfer function.

$$H(z) = \frac{z + 1}{z^2 + z + 1}$$

Create the discrete-time transfer function with a sample time of 0.1 seconds.

```
Hd = tf([1 1],[1 1 1],0.1);
```

Specify the discretization method as bilinear (Tustin) approximation and the prewarp frequency as 20 rad/seconds.

```
opts = d2cOptions('Method','tustin','PrewarpFrequency',20);
```

Convert the discrete-time model to continuous-time using the specified discretization method.

```
Hc = d2c(Hd,opts);
```

You can use the discretization option set `opts` to discretize additional models using the same options.

Version History

Introduced in R2010a

References

- [1] Franklin, G.F., Powell,D.J., and Workman, M.L., *Digital Control of Dynamic Systems* (3rd Edition), Prentice Hall, 1997.

See Also

`d2c`

d2d

Resample discrete-time model

Syntax

```
sys1 = d2d(sys, Ts)
sys1 = d2d(sys, Ts, 'method')
sys1 = d2d(sys, Ts, opts)
```

Description

`sys1 = d2d(sys, Ts)` resamples the discrete-time dynamic system model `sys` to produce an equivalent discrete-time model `sys1` with the new sample time `Ts` (in seconds), using zero-order hold on the inputs.

`sys1 = d2d(sys, Ts, 'method')` uses the specified resampling method `'method'`:

- `'zoh'` — Zero-order hold on the inputs
- `'tustin'` — Bilinear (Tustin) approximation

For information about the algorithms for each `d2d` conversion method, see “Continuous-Discrete Conversion Methods”.

`sys1 = d2d(sys, Ts, opts)` resamples `sys` using the option set with `d2dOptions`.

Examples

Resample a Discrete-Time Model

Create the following zero-pole-gain-model with sample time 0.1 seconds.

$$H(z) = \frac{z - 0.7}{z - 0.5}$$

```
H = zpkm(0.7,0.5,1,0.1);
```

Resample the model at 0.05 s.

```
H2 = d2d(H,0.05)
```

```
H2 =
```

```
(z-0.8243)
-----
(z-0.7071)
```

```
Sample time: 0.05 seconds
Discrete-time zero/pole/gain model.
```

Resample `H2` at 0.1 seconds to obtain the original model `H`.

```
H3 = d2d(H2,0.1)
```

```
H3 =
```

```
(z-0.7)
-----
(z-0.5)
```

```
Sample time: 0.1 seconds
Discrete-time zero/pole/gain model.
```

Resample an Identified Discrete-Time Model

Suppose that you estimate a discrete-time output-error polynomial model with sample time commensurate with the estimation data (0.1 seconds). However, your application requires a faster sampling frequency (0.01 seconds). You can use `d2d` to resample your estimated model.

Load the estimation data.

```
load iddata1 z1
z1.Ts
```

```
ans = 0.1000
```

`z1` is an `iddata` object containing the estimation input-output data with sample time 0.1 seconds.

Estimate an output-error polynomial model of order [2 2 1].

```
sys = oe(z1,[2 2 1]);
sys.Ts
```

```
ans = 0.1000
```

Resample the model at sample time 0.01 seconds.

```
sys2 = d2d(sys,0.01);
sys2.Ts
```

```
ans = 0.0100
```

`d2d` resamples the model using the zero-order hold method.

Tips

- Use the syntax `sys1 = d2d(sys,Ts,'method')` to resample `sys` using the default options for 'method'. To specify `tustin` resampling with a frequency prewarp, use the syntax `sys1 = d2d(sys,Ts,opts)`. For more information, see `d2doptions`.
- When `sys` is an identified (IDLTI) model, `sys1` does not include the estimated parameter covariance of `sys`. If you want to translate the covariance while converting the model, use `translatecov`.

Version History

Introduced before R2006a

See Also

d2dOptions | c2d | d2c | upsample | translatecov

d2dOptions

Create option set for discrete-time resampling

Syntax

```
opts = d2dOptions
opts = d2dOptions('OptionName', OptionValue)
```

Description

`opts = d2dOptions` returns the default options for `d2d`.

`opts = d2dOptions('OptionName', OptionValue)` accepts one or more comma-separated name-value pairs that specify options for the `d2d` command. Specify *OptionName* inside single quotes.

This table summarizes the options that the `d2d` command supports.

Input Arguments

Name-Value Pair Arguments

Method

Discretization method, specified as one of the following values:

'zoh'	Zero-order hold, where <code>d2d</code> assumes that the control inputs are piecewise constant over the sample time <code>Ts</code> .
'tustin'	Bilinear (Tustin) approximation. By default, <code>d2d</code> resamples with no prewarp. To include prewarp, use the <code>PrewarpFrequency</code> option.

For information about the algorithms for each `d2d` conversion method, see “Continuous-Discrete Conversion Methods”.

Default: 'zoh'

PrewarpFrequency

Prewarp frequency for 'tustin' method, specified in `rad/TimeUnit`, where `TimeUnit` is the time units, specified in the `TimeUnit` property, of the resampled system. Takes positive scalar values. The prewarp frequency must be smaller than the Nyquist frequency before and after resampling. A value of 0 corresponds to the standard 'tustin' method without prewarp.

Default: 0

Examples

Specify Method for Resampling a Discrete-Time Model

Create the following discrete-time transfer function with sample time 0.1 seconds.

$$H(z) = \frac{z + 1}{z^2 + z + 1}$$

```
h1 = tf([1 1],[1 1 1],0.1);
```

Specify the discretization method as bilinear Tustin method with a prewarping frequency of 20 rad/seconds.

```
opts = d2dOptions('Method','tustin','PrewarpFrequency',20);
```

Resample the discrete-time model using the specified options.

```
h2 = d2d(h1,0.05,opts);
```

You can use the option set `opts` to resample additional models using the same options.

Version History

Introduced in R2010a

See Also

d2d

damp

Natural frequency and damping ratio

Syntax

```
damp(sys)
```

```
[wn,zeta] = damp(sys)
[wn,zeta,p] = damp(sys)
```

Description

`damp(sys)` displays the damping ratio, natural frequency, and time constant of the poles of the linear model `sys`. For a discrete-time model, the table also includes the magnitude of each pole. The poles are sorted in increasing order of frequency values.

`[wn,zeta] = damp(sys)` returns the natural frequencies `wn`, and damping ratios `zeta` of the poles of `sys`.

`[wn,zeta,p] = damp(sys)` also returns the poles `p` of `sys`.

Examples

Display Natural Frequency, Damping Ratio, and Poles of Continuous-Time System

For this example, consider the following continuous-time transfer function:

$$\text{sys}(s) = \frac{2s^2 + 5s + 1}{s^3 + 2s - 3}$$

Create the continuous-time transfer function.

```
sys = tf([2,5,1],[1,0,2,-3]);
```

Display the natural frequencies, damping ratios, time constants, and poles of `sys`.

```
damp(sys)
```

Pole	Damping	Frequency (rad/seconds)	Time Constant (seconds)
1.00e+00	-1.00e+00	1.00e+00	-1.00e+00
-5.00e-01 + 1.66e+00i	2.89e-01	1.73e+00	2.00e+00
-5.00e-01 - 1.66e+00i	2.89e-01	1.73e+00	2.00e+00

The poles of `sys` contain an unstable pole and a pair of complex conjugates that lie in the left-half of the s -plane. The corresponding damping ratio for the unstable pole is -1, which is called a driving force instead of a damping force since it increases the oscillations of the system, driving the system to instability.

Display Natural Frequency, Damping Ratio, and Poles of Discrete-Time System

For this example, consider the following discrete-time transfer function with a sample time of 0.01 seconds:

$$\text{sys}(z) = \frac{5z^2 + 3z + 1}{z^3 + 6z^2 + 4z + 4}$$

Create the discrete-time transfer function.

```
sys = tf([5 3 1],[1 6 4 4],0.01)
```

```
sys =
```

$$\frac{5 z^2 + 3 z + 1}{z^3 + 6 z^2 + 4 z + 4}$$

```
Sample time: 0.01 seconds
Discrete-time transfer function.
```

Display information about the poles of sys using the damp command.

```
damp(sys)
```

Pole	Magnitude	Damping	Frequency (rad/seconds)	Time Constant (seconds)
-3.02e-01 + 8.06e-01i	8.61e-01	7.74e-02	1.93e+02	6.68e-02
-3.02e-01 - 8.06e-01i	8.61e-01	7.74e-02	1.93e+02	6.68e-02
-5.40e+00	5.40e+00	-4.73e-01	3.57e+02	-5.93e-03

The Magnitude column displays the discrete-time pole magnitudes. The Damping, Frequency, and Time Constant columns display values calculated using the equivalent continuous-time poles.

Natural Frequency and Damping Ratio of Zero-Pole-Gain Model

For this example, create a discrete-time zero-pole-gain model with two outputs and one input. Use sample time of 0.1 seconds.

```
sys = zpk({0;-0.5},{0.3;[0.1+1i,0.1-1i]],[1;2],0.1)
```

```
sys =
```

```
From input to output...
      z
1:  -----
   (z-0.3)

      2 (z+0.5)
2:  -----
```

$$(z^2 - 0.2z + 1.01)$$

Sample time: 0.1 seconds
Discrete-time zero/pole/gain model.

Compute the natural frequency and damping ratio of the zero-pole-gain model `sys`.

```
[wn,zeta] = damp(sys)
```

```
wn = 3×1
```

```
12.0397  
14.7114  
14.7114
```

```
zeta = 3×1
```

```
1.0000  
-0.0034  
-0.0034
```

Each entry in `wn` and `zeta` corresponds to combined number of I/Os in `sys`. `zeta` is ordered in increasing order of natural frequency values in `wn`.

Compute Natural Frequency, Damping Ratio and Poles of a State-Space Model

For this example, compute the natural frequencies, damping ratio and poles of the following state-space model:

$$A = \begin{bmatrix} -2 & -1 \\ 1 & -2 \end{bmatrix}, \quad B = \begin{bmatrix} 1 & 1 \\ 2 & -1 \end{bmatrix}, \quad C = [1 \ 0], \quad D = [0 \ 1].$$

Create the state-space model using the state-space matrices.

```
A = [-2 -1;1 -2];  
B = [1 1;2 -1];  
C = [1 0];  
D = [0 1];  
sys = ss(A,B,C,D);
```

Use `damp` to compute the natural frequencies, damping ratio and poles of `sys`.

```
[wn,zeta,p] = damp(sys)
```

```
wn = 2×1
```

```
2.2361  
2.2361
```

```
zeta = 2×1
```

```
0.8944
```

```
0.8944
```

```
p = 2x1 complex
-2.0000 + 1.0000i
-2.0000 - 1.0000i
```

The poles of `sys` are complex conjugates lying in the left half of the s-plane. The corresponding damping ratio is less than 1. Hence, `sys` is an underdamped system.

Input Arguments

sys — Linear dynamic system

dynamic system model

Linear dynamic system, specified as a SISO, or MIMO dynamic system model. Dynamic systems that you can use include:

- Continuous-time or discrete-time numeric LTI models, such as `tf`, `zpk`, or `ss` models.
- Generalized or uncertain LTI models such as `genss` or `uss` models. (Using uncertain models requires Robust Control Toolbox software.)

`damp` assumes

- current values of the tunable components for tunable control design blocks.
- nominal model values for uncertain control design blocks.

Output Arguments

wn — Natural frequency of each pole

vector

Natural frequency of each pole of `sys`, returned as a vector sorted in ascending order of frequency values. Frequencies are expressed in units of the reciprocal of the `TimeUnit` property of `sys`.

If `sys` is a discrete-time model with specified sample time, `wn` contains the natural frequencies of the equivalent continuous-time poles. If the sample time is not specified, then `damp` assumes a sample time value of 1 and calculates `wn` accordingly. For more information, see “Algorithms” on page 2-218.

zeta — Damping ratio of each pole

vector

Damping ratios of each pole, returned as a vector sorted in the same order as `wn`.

If `sys` is a discrete-time model with specified sample time, `zeta` contains the damping ratios of the equivalent continuous-time poles. If the sample time is not specified, then `damp` assumes a sample time value of 1 and calculates `zeta` accordingly. For more information, see “Algorithms” on page 2-218.

p — Poles of the dynamic system model

vector

Poles of the dynamic system model, returned as a vector sorted in the same order as `wn`. `p` is the same as the output of `pole(sys)`, except for the order. For more information on poles, see `pole`.

Algorithms

`damp` computes the natural frequency, time constant, and damping ratio of the system poles as defined in the following table:

	Continuous Time	Discrete Time with Sample Time T_s
Pole Location	s	z
Equivalent Continuous-Time Pole	Not applicable	$s = \frac{\ln(z)}{T_s}$
Natural Frequency	$\omega_n = s $	$\omega_n = s = \left \frac{\ln(z)}{T_s} \right $
Damping Ratio	$\zeta = -\cos(\angle s)$	$\zeta = -\cos(\angle s) = -\cos(\angle \ln(z))$
Time Constant	$\tau = \frac{1}{\omega_n \zeta}$	$\tau = \frac{1}{\omega_n \zeta}$

If the sample time is not specified, then `damp` assumes a sample time value of 1 and calculates `zeta` accordingly.

Version History

Introduced before R2006a

See Also

`eig` | `esort` | `dsort` | `pole` | `pzmap` | `zero`

dare

(Not recommended) Solve discrete-time algebraic Riccati equations (DAREs)

Note dare is not recommended. Use `idare` instead. For more information, see “Compatibility Considerations”.

Syntax

```
[X,L,G] = dare(A,B,Q,R)
[X,L,G] = dare(A,B,Q,R,S,E)
[X,L,G,report] = dare(A,B,Q,...)
[X1,X2,L,report] = dare(A,B,Q,...,'factor')
```

Description

`[X,L,G] = dare(A,B,Q,R)` computes the unique stabilizing solution X of the discrete-time algebraic Riccati equation

$$A^T X A - X - A^T X B (B^T X B + R)^{-1} B^T X A + Q = 0$$

The `dare` function also returns the gain matrix, $G = (B^T X B + R)^{-1} B^T X A$, and the vector L of closed loop eigenvalues, where

$$L = \text{eig}(A - B * G, E)$$

`[X,L,G] = dare(A,B,Q,R,S,E)` solves the more general discrete-time algebraic Riccati equation,

$$A^T X A - E^T X E - (A^T X B + S)(B^T X B + R)^{-1} (B^T X A + S^T) + Q = 0$$

or, equivalently, if R is nonsingular,

$$E^T X E = F^T X F - F^T X B (B^T X B + R)^{-1} B^T X F + Q - S R^{-1} S^T$$

where $F = A - B R^{-1} S^T$. When omitted, R , S , and E are set to the default values $R=I$, $S=0$, and $E=I$.

The `dare` function returns the corresponding gain matrix $G = (B^T X B + R)^{-1} (B^T X A + S^T)$

and a vector L of closed-loop eigenvalues, where

$$L = \text{eig}(A - B * G, E)$$

`[X,L,G,report] = dare(A,B,Q,...)` returns a diagnosis report with value:

- -1 when the associated symplectic pencil has eigenvalues on or very near the unit circle
- -2 when there is no finite stabilizing solution X
- The Frobenius norm if X exists and is finite

`[X1,X2,L,report] = dare(A,B,Q,...,'factor')` returns two matrices, X1 and X2, and a diagonal scaling matrix D such that $X = D*(X2/X1)*D$. The vector L contains the closed-loop eigenvalues. All outputs are empty when the associated Symplectic matrix has eigenvalues on the unit circle.

Limitations

The (A, B) pair must be stabilizable (that is, all eigenvalues of A outside the unit disk must be controllable). In addition, the associated symplectic pencil must have no eigenvalue on the unit circle. Sufficient conditions for this to hold are (Q, A) detectable when $S = 0$ and $R > 0$, or

$$\begin{bmatrix} Q & S \\ S^T & R \end{bmatrix} > 0$$

Algorithms

`dare` implements the algorithms described in [1]. It uses the QZ algorithm to deflate the extended symplectic pencil and compute its stable invariant subspace.

Version History

Introduced before R2006a

dare not recommended

Not recommended starting in R2019a

Starting in R2019a, use the `idare` command to solve discrete-time Riccati equations. This approach has improved accuracy through better scaling and the computation of K is more accurate when R is ill-conditioned relative to `dare`. Furthermore, `idare` includes an optional `info` structure to gather the implicit solution data of the Riccati equation.

The following table shows some typical uses of `dare` and how to update your code to use `idare` instead.

Not Recommended	Recommended
<code>[X,L,G] = dare(A,B,Q,R,S,E)</code>	<code>[X,K,L] = idare(A,B,Q,R,S,E)</code> computes the stabilizing solution X, the state-feedback gain K and the closed-loop eigenvalues L of the discrete-time algebraic Riccati equation. For more information, see <code>idare</code> .
<code>[X,L,G,report] = dare(A,B,Q,R,S,E)</code>	<code>[X,K,L,info] = idare(A,B,Q,R,S,E)</code> computes the stabilizing solution X, the state-feedback gain K, the closed-loop eigenvalues L of the discrete-time algebraic Riccati equation. The <code>info</code> structure contains the implicit solution data. For more information, see <code>idare</code> .

There are no plans to remove `dare` at this time.

References

- [1] Arnold, W.F., III and A.J. Laub, "Generalized Eigenproblem Algorithms and Software for Algebraic Riccati Equations," *Proc. IEEE*, 72 (1984), pp. 1746-1754.

See Also

idare

db2mag

Convert decibels (dB) to magnitude

Syntax

```
y = db2mag(ydb)
```

Description

`y = db2mag(ydb)` returns the magnitude measurements, `y`, that correspond to the decibel (dB) values specified in `ydb`. The relationship between magnitude and decibels is $ydb = 20 * \log_{10}(y)$

Examples

Magnitude of Elements in an Array

For this example, generate a 2-by-3-by-4 array of Gaussian random numbers. Assume the numbers are expressed in decibels and compute the corresponding magnitudes.

```
rng('default');  
ydb = randn(2,3,4);  
y = db2mag(ydb)  
  
y =  
y(:,:,1) =  
  
    1.0639    0.7710    1.0374  
    1.2351    1.1044    0.8602  
  
y(:,:,2) =  
  
    0.9513    1.5098    0.8561  
    1.0402    1.3755    1.4182  
  
y(:,:,3) =  
  
    1.0871    1.0858    0.9858  
    0.9928    0.9767    1.1871  
  
y(:,:,4) =  
  
    1.1761    1.0804    1.0861  
    1.1772    0.8702    1.2065
```

Use the definition to check the calculation.

```
chck = 10.^(ydb/20)
```



```

chck =
chck(:,:,1) =

    1.0639    0.7710    1.0374
    1.2351    1.1044    0.8602

```

```

chck(:,:,2) =

    0.9513    1.5098    0.8561
    1.0402    1.3755    1.4182

```

```

chck(:,:,3) =

    1.0871    1.0858    0.9858
    0.9928    0.9767    1.1871

```

```

chck(:,:,4) =

    1.1761    1.0804    1.0861
    1.1772    0.8702    1.2065

```

Input Arguments

ydb — Input array in decibels

scalar | vector | matrix | array

Input array in decibels, specified as a scalar, vector, matrix, or an array. When ydb is nonscalar, db2mag is an element-wise operation.

Data Types: single | double

Output Arguments

y — Magnitude measurements

scalar | vector | matrix | array

Magnitude measurements, returned as a scalar, vector, matrix, or an array of the same size as ydb.

Version History

Introduced in R2008a

See Also

mag2db

dcgain

Low-frequency (DC) gain of LTI system

Syntax

```
k = dcgain(sys)
```

Description

`k = dcgain(sys)` computes the DC gain `k` of the LTI model `sys`.

Continuous Time

The continuous-time DC gain is the transfer function value at the frequency $s = 0$. For state-space models with matrices (A, B, C, D) , this value is

$$K = D - CA^{-1}B$$

Discrete Time

The discrete-time DC gain is the transfer function value at $z = 1$. For state-space models with matrices (A, B, C, D) , this value is

$$K = D + C(I - A)^{-1}B$$

Examples

Compute the DC Gain of a MIMO Transfer Function

Create the following 2-input 2-output continuous-time transfer function.

$$H(s) = \begin{bmatrix} 1 & \frac{s-1}{s^2+s+3} \\ \frac{1}{s+1} & \frac{s+2}{s-3} \end{bmatrix}$$

```
H = [1 tf([1 -1],[1 1 3]) ; tf(1,[1 1]) tf([1 2],[1 -3])];
```

Compute the DC gain of the transfer function. For continuous-time models, the DC gain is the transfer function value at the frequency $s = 0$.

```
K = dcgain(H)
```

```
K = 2x2
```

```
1.0000 -0.3333
1.0000 -0.6667
```

The DC gain for each input-output pair is returned. $K(i, j)$ is the DC gain from input j to output i .

Compute DC Gain of Identified Model

Load the estimation data.

```
load iddata1 z1
```

z1 is an iddata object containing the input-output estimation data.

Estimate a process model from the data. Specify that the model has one pole and a time delay term.

```
sys = procest(z1, 'PID')
```

```
sys =
```

```
Process model with transfer function:
```

$$G(s) = \frac{K_p}{1+T_{p1}s} * \exp(-T_d*s)$$

$$\begin{aligned} K_p &= 9.0754 \\ T_{p1} &= 0.25655 \\ T_d &= 0.068 \end{aligned}$$

```
Parameterization:
```

```
{'PID'}
```

```
Number of free coefficients: 3
```

```
Use "getpvec", "getcov" for parameters and their uncertainties.
```

```
Status:
```

```
Estimated using PROCEST on time domain data "z1".
```

```
Fit to estimation data: 44.85%
```

```
FPE: 6.02, MSE: 5.901
```

Compute the DC gain of the model.

```
K = dcgain(sys)
```

```
K = 9.0754
```

This DC gain value is stored in the Kp property of sys.

```
sys.Kp
```

```
ans = 9.0754
```

Tips

The DC gain is infinite for systems with integrators.

Version History

Introduced before R2006a

See Also

evalfr | norm

delay2z

Replace delays of discrete-time TF, SS, or ZPK models by poles at $z=0$, or replace delays of FRD models by phase shift

Note delay2z has been removed. Use absorbDelay instead.

Version History

Introduced before R2006a

delays

Create state-space models with delayed inputs, outputs, and states

Syntax

```
sys=delays(A,B,C,D,delayterms)
sys=delays(A,B,C,D,ts,delayterms)
```

Description

`sys=delays(A,B,C,D,delayterms)` constructs a continuous-time state-space model of the form:

$$\frac{dx}{dt} = Ax(t) + Bu(t) + \sum_{j=1}^N (A_j x(t-t_j) + B_j u(t-t_j))$$

$$y(t) = Cx(t) + Du(t) + \sum_{j=1}^N (C_j x(t-t_j) + D_j u(t-t_j))$$

where $t_j, j=1,\dots,N$ are time delays expressed in seconds. `delayterms` is a struct array with fields `delay`, `a`, `b`, `c`, `d` where the fields of `delayterms(j)` contain the values of t_j , A_j , B_j , C_j , and D_j , respectively. The resulting model `sys` is a state-space (SS) model with internal delays.

`sys=delays(A,B,C,D,ts,delayterms)` constructs the discrete-time counterpart:

$$x[k+1] = Ax[k] + Bu[k] + \sum_{j=1}^N \{A_j x[k-n_j] + B_j u[k-n_j]\}$$

$$y[k] = Cx[k] + Du[k] + \sum_{j=1}^N \{C_j x[k-n_j] + D_j u[k-n_j]\}$$

where $N_j, j=1,\dots,N$ are time delays expressed as integer multiples of the sample time `ts`.

Examples

To create the model:

$$\frac{dx}{dt} = x(t) - x(t-1.2) + 2u(t-0.5)$$

$$y(t) = x(t-0.5) + u(t)$$

type

```
DelayT(1) = struct('delay',0.5,'a',0,'b',2,'c',1,'d',0);
DelayT(2) = struct('delay',1.2,'a',-1,'b',0,'c',0,'d',0);
sys = delays(1,0,0,1,DelayT)
```

a =

```
    x1
x1    0
```

```
b =  
      u1  
x1   2
```

```
c =  
      x1  
y1   1
```

```
d =  
      u1  
y1   1
```

(values computed with all internal delays set to zero)

Internal delays: 0.5 0.5 1.2

Continuous-time model.

Version History

Introduced in R2007a

See Also

[getDelayModel](#) | [ss](#)

dlqr

Linear-quadratic (LQ) state-feedback regulator for discrete-time state-space system

Syntax

`[K,S,e] = dlqr(A,B,Q,R,N)`

Description

`[K,S,e] = dlqr(A,B,Q,R,N)` calculates the optimal gain matrix K such that the state-feedback law

$$u[n] = -Kx[n]$$

minimizes the quadratic cost function

$$J(u) = \sum_{n=1}^{\infty} (x[n]^T Q x[n] + u[n]^T R u[n] + 2x[n]^T N u[n])$$

for the discrete-time state-space model

$$x[n+1] = Ax[n] + Bu[n]$$

The default value $N=0$ is assumed when N is omitted.

In addition to the state-feedback gain K , `dlqr` returns the infinite horizon solution S of the associated discrete-time Riccati equation

$$A^T S A - S - (A^T S B + N)(B^T S B + R)^{-1}(B^T S A + N^T) + Q = 0$$

and the closed-loop eigenvalues $e = \text{eig}(A-B*K)$. Note that K is derived from S by

$$K = (B^T S B + R)^{-1}(B^T S A + N^T)$$

Limitations

The problem data must satisfy:

- The pair (A, B) is stabilizable.
- $R > 0$ and $Q - NR^{-1}N^T \geq 0$
- $(Q - NR^{-1}N^T, A - BR^{-1}N^T)$ has no unobservable mode on the unit circle.

Version History

Introduced before R2006a

See Also

dare | lqgreg | lqr | lqrd | lqry

dlyap

Solve discrete-time Lyapunov equations

Syntax

```
X = dlyap(A,Q)
X = dlyap(A,B,C)
X = dlyap(A,Q,[],E)
```

Description

$X = \text{dlyap}(A, Q)$ solves the discrete-time Lyapunov equation $AXA^T - X + Q = 0$,

where A and Q are n -by- n matrices.

The solution X is symmetric when Q is symmetric, and positive definite when Q is positive definite and A has all its eigenvalues inside the unit disk.

$X = \text{dlyap}(A, B, C)$ solves the Sylvester equation $AXB - X + C = 0$,

where A , B , and C must have compatible dimensions but need not be square.

$X = \text{dlyap}(A, Q, [], E)$ solves the generalized discrete-time Lyapunov equation $AXA^T - EXE^T + Q = 0$,

where Q is a symmetric matrix. The empty square brackets, `[]`, are mandatory. If you place any values inside them, the function will error out.

Diagnostics

The discrete-time Lyapunov equation has a (unique) solution if the eigenvalues $\alpha_1, \alpha_2, \dots, \alpha_N$ of A satisfy $\alpha_i \alpha_j \neq 1$ for all (i, j) .

If this condition is violated, `dlyap` produces the error message

```
Solution does not exist or is not unique.
```

Algorithms

`dlyap` uses SLICOT routines SB03MD and SG03AD for Lyapunov equations and SB04QD (SLICOT) for Sylvester equations.

Version History

Introduced before R2006a

References

- [1] Barraud, A.Y., "A numerical algorithm to solve $A X A - X = Q$," *IEEE Trans. Auto. Contr.*, AC-22, pp. 883-885, 1977.
- [2] Bartels, R.H. and G.W. Stewart, "Solution of the Matrix Equation $A X + X B = C$," *Comm. of the ACM*, Vol. 15, No. 9, 1972.
- [3] Hammarling, S.J., "Numerical solution of the stable, non-negative definite Lyapunov equation," *IMA J. Num. Anal.*, Vol. 2, pp. 303-325, 1982.
- [4] Higham, N.J., "FORTRAN codes for estimating the one-norm of a real or complex matrix, with applications to condition estimation," *A.C.M. Trans. Math. Soft.*, Vol. 14, No. 4, pp. 381-396, 1988.
- [5] Penzl, T., "Numerical solution of generalized Lyapunov equations," *Advances in Comp. Math.*, Vol. 8, pp. 33-48, 1998.
- [6] Golub, G.H., Nash, S. and Van Loan, C.F. "A Hessenberg-Schur method for the problem $A X + X B = C$," *IEEE Trans. Auto. Contr.*, AC-24, pp. 909-913, 1979.
- [7] Sima, V. C, "Algorithms for Linear-quadratic Optimization," Marcel Dekker, Inc., New York, 1996.

See Also

covar | lyap

dlyapchol

Square-root solver for discrete-time Lyapunov equations

Syntax

```
R = dlyapchol(A,B)
R = dlyapchol(A,B,E)
```

Description

`R = dlyapchol(A,B)` computes a Cholesky factorization $X = R' * R$ of the solution X to the Lyapunov matrix equation:

$$A * X * A' - X + B * B' = 0$$

All eigenvalues of A matrix must lie in the open unit disk for R to exist.

`R = dlyapchol(A,B,E)` computes a Cholesky factorization $X = R' * R$ of X solving the Sylvester equation

$$A * X * A' - E * X * E' + B * B' = 0$$

All generalized eigenvalues of (A,E) must lie in the open unit disk for R to exist.

Algorithms

`dlyapchol` uses SLICOT routines SB03OD and SG03BD.

Version History

Introduced before R2006a

References

- [1] Bartels, R.H. and G.W. Stewart, "Solution of the Matrix Equation $AX + XB = C$," *Comm. of the ACM*, Vol. 15, No. 9, 1972.
- [2] Hammarling, S.J., "Numerical solution of the stable, non-negative definite Lyapunov equation," *IMA J. Num. Anal.*, Vol. 2, pp. 303-325, 1982.
- [3] Penzl, T., "Numerical solution of generalized Lyapunov equations," *Advances in Comp. Math.*, Vol. 8, pp. 33-48, 1998.

See Also

`dlyap` | `lyapchol`

drss

Generate random discrete test model

Syntax

```
sys = drss(n)
drss(n,p)
drss(n,p,m)
drss(n,p,m,s1,...sn)
```

Description

`sys = drss(n)` generates an n -th order model with one input and one output, and returns the model in the state-space object `sys`. The poles of `sys` are random and stable with the possible exception of poles at $z = 1$ (integrators).

`drss(n,p)` generates an n -th order model with one input and p outputs.

`drss(n,p,m)` generates an n -th order model with p outputs and m inputs.

`drss(n,p,m,s1,...sn)` generates a $s1$ -by- sn array of n -th order models with m inputs and p outputs.

In all cases, the discrete-time state-space model or array returned by `drss` has an unspecified sample time. To generate transfer function or zero-pole-gain systems, convert `sys` using `tf` or `zpk`.

Examples

Generate a discrete LTI system with three states, four outputs, and two inputs.

```
sys = drss(3,4,2)
```

a =

	x1	x2	x3
x1	0.4766	0.1102	-0.7222
x2	0.1102	0.9115	0.1628
x3	-0.7222	0.1628	-0.202

b =

	u1	u2
x1	-0.4326	0.2877
x2	-0	-0
x3	0	1.191

c =

	x1	x2	x3
y1	1.189	-0.1867	-0
y2	-0.03763	0.7258	0.1139
y3	0.3273	-0.5883	1.067
y4	0.1746	2.183	0

```
d =  
      u1      u2  
y1 -0.09565      0  
y2 -0.8323      1.624  
y3  0.2944 -0.6918  
y4      -0      0.858
```

Sample time: unspecified
Discrete-time model.

Version History

Introduced before R2006a

See Also

[rss](#) | [tf](#) | [zpk](#)

dsort

Sort discrete-time poles by magnitude

Syntax

```
dsort  
[s,ndx] = dsort(p)
```

Description

`dsort` sorts the discrete-time poles contained in the vector `p` in descending order by magnitude. Unstable poles appear first.

When called with one lefthand argument, `dsort` returns the sorted poles in `s`.

`[s,ndx] = dsort(p)` also returns the vector `ndx` containing the indices used in the sort.

Examples

Sort the following discrete poles.

```
p =  
-0.2410 + 0.5573i  
-0.2410 - 0.5573i  
 0.1503  
-0.0972  
-0.2590
```

```
s = dsort(p)
```

```
s =  
-0.2410 + 0.5573i  
-0.2410 - 0.5573i  
-0.2590  
 0.1503  
-0.0972
```

Limitations

The poles in the vector `p` must appear in complex conjugate pairs.

Version History

Introduced before R2006a

See Also

`eig` | `esort` | `sort` | `pole` | `pzmap` | `zero`

dss

Create descriptor state-space models

Syntax

```
sys = dss(A,B,C,D,E)
sys = dss(A,B,C,D,E,Ts)
sys = dss(A,B,C,D,E,ltisys)
```

Description

`sys = dss(A,B,C,D,E)` creates the continuous-time descriptor state-space model

$$E \frac{dx}{dt} = Ax + Bu$$

$$y = Cx + Du$$

The output `sys` is an SS model storing the model data (see “State-Space Models”). Note that `ss` produces the same type of object. If the matrix $D = \mathbf{0}$, you can simply set `d` to the scalar $\mathbf{0}$ (zero).

`sys = dss(A,B,C,D,E,Ts)` creates the discrete-time descriptor model

$$Ex[n + 1] = Ax[n] + Bu[n]$$

$$y[n] = Cx[n] + Du[n]$$

with sample time `Ts` (in seconds).

`sys = dss(A,B,C,D,E,ltisys)` creates a descriptor model with properties inherited from the LTI model `ltisys` (including the sample time).

Any of the previous syntaxes can be followed by property name/property value pairs

'Property',Value

Each pair specifies a particular LTI property of the model, for example, the input names or some notes on the model history. See `set` and the example below for details.

Examples

The command

```
sys = dss(1,2,3,4,5,'inputdelay',0.1,'inputname','voltage',...
         'notes','Just an example');
```

creates the model

$$5\dot{x} = x + 2u$$

$$y = 3x + 4u$$

with a 0.1 second input delay. The input is labeled 'voltage', and a note is attached to tell you that this is just an example.

Version History

Introduced before R2006a

See Also

dssdata | get | set | ss

dssdata

Extract descriptor state-space data

Syntax

```
[A,B,C,D,E] = dssdata(sys)
[A,B,C,D,E,Ts] = dssdata(sys)
```

Description

`[A,B,C,D,E] = dssdata(sys)` returns the values of the A, B, C, D, and E matrices for the descriptor state-space model `sys` (see `dss`). `dssdata` equals `ssdata` for regular state-space models (i.e., when $E=I$).

If `sys` has internal delays, A, B, C, D are obtained by first setting all internal delays to zero (creating a zero-order Padé approximation). For some systems, setting delays to zero creates singular algebraic loops, which result in either improper or ill-defined, zero-delay approximations. For these systems, `dssdata` cannot display the matrices and returns an error. This error does not imply a problem with the model `sys` itself.

`[A,B,C,D,E,Ts] = dssdata(sys)` also returns the sample time `Ts`.

You can access other properties of `sys` using `get` or direct structure-like referencing (e.g., `sys.Ts`).

For arrays of SS models with variable order, use the syntax

```
[A,B,C,D,E] = dssdata(sys,'cell')
```

to extract the state-space matrices of each model as separate cells in the cell arrays A, B, C, D, and E.

Version History

Introduced before R2006a

See Also

`dss` | `get` | `getDelayModel` | `ssdata`

esort

Sort continuous-time poles by real part

Syntax

```
s = esort(p)
[s,ndx] = esort(p)
```

Description

`esort` sorts the continuous-time poles contained in the vector `p` by real part. Unstable eigenvalues appear first and the remaining poles are ordered by decreasing real parts.

When called with one left-hand argument, `s = esort(p)` returns the sorted eigenvalues in `s`.

`[s,ndx] = esort(p)` returns the additional argument `ndx`, a vector containing the indices used in the sort.

Examples

Sort the following continuous eigenvalues.

```
p
p =
  -0.2410+ 0.5573i
  -0.2410- 0.5573i
   0.1503
  -0.0972
  -0.2590
```

```
esort(p)
```

```
ans =
   0.1503
  -0.0972
  -0.2410+ 0.5573i
  -0.2410- 0.5573i
  -0.2590
```

Limitations

The eigenvalues in the vector `p` must appear in complex conjugate pairs.

Version History

Introduced before R2006a

See Also

`dsort` | `sort` | `eig` | `pole` | `pzmap` | `zero`

estim

Form state estimator given estimator gain

Syntax

```
est = estim(sys,L)
est = estim(sys,L,sensors,known)
```

Description

`est = estim(sys,L)` produces a state/output estimator `est` given the plant state-space model `sys` and the estimator gain `L`. All inputs w of `sys` are assumed stochastic (process and/or measurement noise), and all outputs y are measured. The estimator `est` is returned in state-space form (SS object).

For a continuous-time plant `sys` with equations

$$\begin{aligned}\dot{x} &= Ax + Bw \\ y &= Cx + Dw\end{aligned}$$

`estim` uses the following equations to generate a plant output estimate \hat{y} and a state estimate \hat{x} , which are estimates of $y(t)=C$ and $x(t)$, respectively:

$$\begin{aligned}\dot{\hat{x}} &= A\hat{x} + L(y - C\hat{x}) \\ \begin{bmatrix} \hat{y} \\ \hat{x} \end{bmatrix} &= \begin{bmatrix} C \\ I \end{bmatrix} \hat{x}\end{aligned}$$

For a discrete-time plant `sys` with the following equations:

$$\begin{aligned}x[n+1] &= Ax[n] + Bw[n] \\ y[n] &= Cx[n] + Dw[n]\end{aligned}$$

`estim` uses estimator equations similar to those for continuous-time to generate a plant output estimate $y[n|n-1]$ and a state estimate $x[n|n-1]$, which are estimates of $y[n]$ and $x[n]$, respectively. These estimates are based on past measurements up to $y[n-1]$.

`est = estim(sys,L,sensors,known)` handles more general plants `sys` with both known (deterministic) inputs u and stochastic inputs w , and both measured outputs y and nonmeasured outputs z .

$$\begin{aligned}\dot{x} &= Ax + B_1w + B_2u \\ \begin{bmatrix} z \\ y \end{bmatrix} &= \begin{bmatrix} C_1 \\ C_2 \end{bmatrix} x + \begin{bmatrix} D_{11} \\ D_{21} \end{bmatrix} w + \begin{bmatrix} D_{12} \\ D_{22} \end{bmatrix} u\end{aligned}$$

The index vectors `sensors` and `known` specify which outputs of `sys` are measured (y), and which inputs of `sys` are known (u). The resulting estimator `est`, found using the following equations, uses both u and y to produce the output and state estimates.

$$\hat{\dot{x}} = A\hat{x} + B_2u + L(y - C_2\hat{x} - D_{22}u)$$

$$\begin{bmatrix} \hat{y} \\ \hat{x} \end{bmatrix} = \begin{bmatrix} C_2 \\ I \end{bmatrix} \hat{x} + \begin{bmatrix} D_{22} \\ 0 \end{bmatrix} u$$

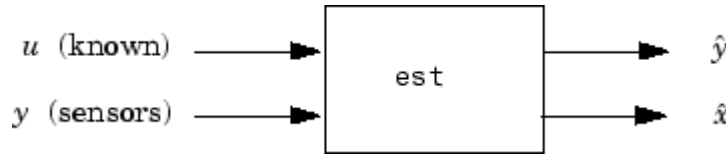

Examples

Consider a state-space model `sys` with seven outputs and four inputs. Suppose you designed a Kalman gain matrix L using outputs 4, 7, and 1 of the plant as sensor measurements and inputs 1, 4, and 3 of the plant as known (deterministic) inputs. You can then form the Kalman estimator by

```
sensors = [4,7,1];
known = [1,4,3];
est = estim(sys,L,sensors,known)
```

See the function `kalman` for direct Kalman estimator design.

Tips

You can use the functions `place` (pole placement) or `kalman` (Kalman filtering) to design an adequate estimator gain L . Note that the estimator poles (eigenvalues of $A-LC$) should be faster than the plant dynamics (eigenvalues of A) to ensure accurate estimation.

Version History

Introduced before R2006a

See Also

`kalman` | `place` | `reg` | `kalmd` | `lqgreg` | `ss` | `ssest` | `predict`

evalfr

Evaluate system response at specific frequency

Syntax

```
frsp = evalfr(sys,f)
```

Description

`evalfr` is a simplified version of `freqresp` meant for quick evaluation of the system response at the Laplace variable value of s or z for a single, specific frequency. Use `freqresp` to evaluate the system response over a set of frequencies. To obtain the magnitude and phase data as well as plots of the frequency response, use `bode` instead.

`frsp = evalfr(sys,f)` evaluates the continuous-time or discrete-time model `sys` at the specified frequency `f`.

Examples

Evaluate Discrete-Time Transfer Function

Create the following discrete-time transfer function.

$$H(z) = \frac{z - 1}{z^2 + z + 1}$$

```
H = tf([1 -1],[1 1 1],-1);
```

Evaluate the transfer function at $z = 1+j$.

```
z = 1+j;
evalfr(H,z)
```

```
ans = 0.2308 + 0.1538i
```

Evaluate Frequency Response of Identified Model at Given Frequency

Create the following continuous-time transfer function model:

$$H(s) = \frac{1}{s^2 + 2s + 1}$$

```
sys = idtf(1,[1 2 1]);
```

Evaluate the transfer function at frequency 0.1 rad/second.

```
w = 0.1;
s = j*w;
evalfr(sys,s)

ans = 0.9705 - 0.1961i
```

Alternatively, use the `freqresp` command.

```
freqresp(sys,w)

ans = 0.9705 - 0.1961i
```

Frequency Response of MIMO State-Space Model

For this example, consider a cube rotating about its corner with inertia tensor J and a damping force F of 0.2 magnitude. The input to the system is the driving torque while the angular velocities are the outputs. The state-space matrices for the cube are:

$$A = -J^{-1}F, \quad B = J^{-1}, \quad C = I, \quad D = 0,$$

$$\text{where, } J = \begin{bmatrix} 8 & -3 & -3 \\ -3 & 8 & -3 \\ -3 & -3 & 8 \end{bmatrix} \text{ and } F = \begin{bmatrix} 0.2 & 0 & 0 \\ 0 & 0.2 & 0 \\ 0 & 0 & 0.2 \end{bmatrix}$$

Specify the A , B , C and D matrices, and create the continuous-time state-space model.

```
J = [8 -3 -3; -3 8 -3; -3 -3 8];
F = 0.2*eye(3);
A = -J\F;
B = inv(J);
C = eye(3);
D = 0;
sys = ss(A,B,C,D);
size(sys)
```

State-space model with 3 outputs, 3 inputs, and 3 states.

Compute the frequency response of the system at 0.2 rad/second. Since `sys` is a continuous-time model, express the frequency in terms of the Laplace variable s .

```
w = 0.2;
s = j*w;
frsp = evalfr(sys,s)

frsp = 3x3 complex

    0.3607 - 0.9672i    0.3197 - 0.5164i    0.3197 - 0.5164i
    0.3197 - 0.5164i    0.3607 - 0.9672i    0.3197 - 0.5164i
    0.3197 - 0.5164i    0.3197 - 0.5164i    0.3607 - 0.9672i
```

Alternatively, you can use the `freqresp` command to evaluate the frequency response using the scalar value of the frequency directly.

```
H = freqresp(sys,w)
```

$H = 3 \times 3$ complex

```
0.3607 - 0.9672i  0.3197 - 0.5164i  0.3197 - 0.5164i
0.3197 - 0.5164i  0.3607 - 0.9672i  0.3197 - 0.5164i
0.3197 - 0.5164i  0.3197 - 0.5164i  0.3607 - 0.9672i
```

Input Arguments

sys — Dynamic system

dynamic system model | model array

Dynamic system, specified as a SISO or MIMO dynamic system model or array of dynamic system models. Dynamic systems that you can use include:

- LTI models such as `ss`, `tf`, and `zpk` models.
- Sparse state-space models, such as `sparss` or `mechss` models.
- Generalized or uncertain state-space models such as `genss` or `uss` models. (Using uncertain models requires Robust Control Toolbox software.)
 - For tunable control design blocks, the function evaluates the model at its current value to evaluate the frequency response.
 - For uncertain control design blocks, the function evaluates the frequency response at the nominal value and random samples of the model.
- Identified state-space models, such as `idss` models. (Using identified models requires System Identification Toolbox software.)

For a complete list of models, see “Dynamic System Models”.

f — Frequency at which to evaluate system response

complex scalar

Frequency at which to evaluate system response, expressed as the Laplace variable s or z , specified as a complex scalar. Specify the frequency in terms of the Laplace variable s or z based on whether `sys` is a continuous-time or discrete-time model, respectively. For instance, if you want to evaluate the frequency response of a system `sys` at a frequency value of w rad/s, then specify `f` in terms of

- $s = jw$, if `sys` is in continuous-time.
- $z = e^{jwT}$, if `sys` is in discrete-time. Here, T is the sample time.

Output Arguments

frsp — Frequency response

complex scalar

Frequency response of the system at `f`, returned as a complex scalar.

Version History

Introduced before R2006a

See Also

bode | freqresp | sigma

evalGoal

Evaluate tuning goals for tuned control system

Syntax

```
[Hspec, fval] = evalGoal(Req,T)
```

Description

[Hspec, fval] = evalGoal(Req,T) returns the normalized value fval of a tuning goal evaluated for a tuned control system T. The evalGoal command also returns the transfer function Hspec used to compute this value.

Examples

Evaluate Requirements for Tuned System

Tune a control system with systune, and evaluate the tuning goals with evalGoal.

Open the Simulink® model rct_airframe2.

```
open_system('rct_airframe2')
```

Two-loop autopilot for controlling the vertical acceleration of an airframe

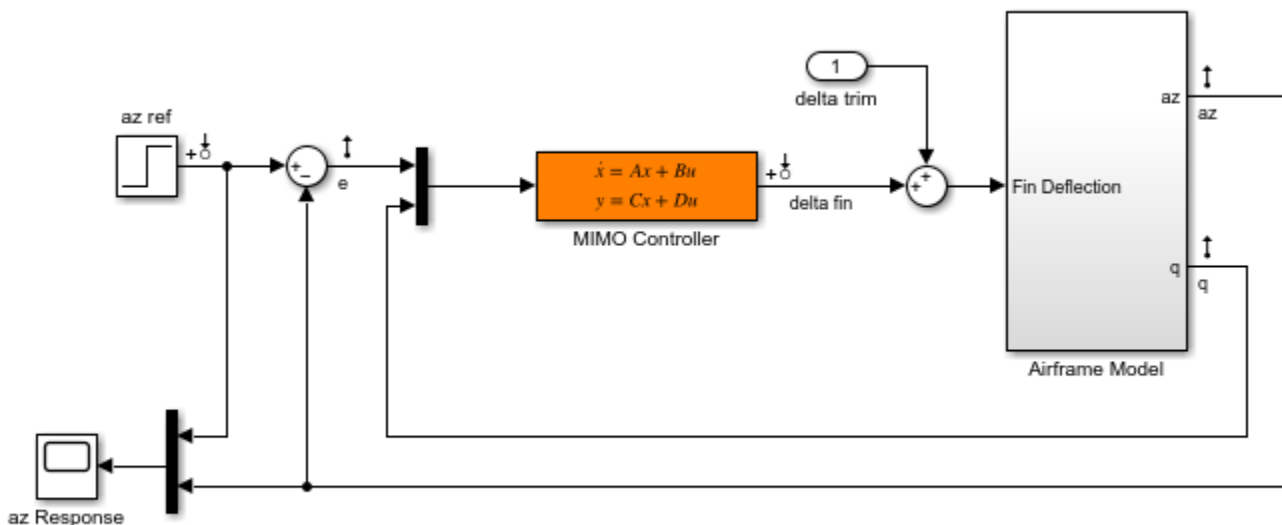

Copyright 2014 The MathWorks, Inc.

Create tracking, roll-off, stability margin, and disturbance rejection requirements for tuning the control system.

```
Req1 = TuningGoal.Tracking('az_ref','az',1);
Req2 = TuningGoal.Gain('delta_fin','delta_fin',tf(25,[1 0]));
Req3 = TuningGoal.Margins('delta_fin',7,45);
MaxGain = frd([2 200 200],[0.02 2 200]);
Req4 = TuningGoal.Gain('delta_fin','az',MaxGain);
```

Create an `sITuner` interface, and tune the model using these tuning goals.

```
ST0 = sITuner('rct_airframe2','MIMO Controller');
rng default
[ST1,fSoft] = systune(ST0,[Req1,Req2,Req3,Req4]);
```

```
Final: Soft = 1.13, Hard = -Inf, Iterations = 94
```

`ST1` is a tuned version of the `sITuner` interface to the control system. `ST1` contains the tuned values of the tunable parameters of the MIMO controller in the model.

Evaluate the margin goal for the tuned system.

```
[hspec,fval] = evalGoal(Req3,ST1);
fval
```

```
fval =
    0.5140
```

The normalized value of the tuning goal is less than 1, indicating that the tuned system satisfies the margin requirement. For more information about how the normalized value of this tuning goal is calculated, see the `TuningGoal.Margins` reference page.

Evaluate the tracking goal for the tuned system.

```
[hspec,fval] = evalGoal(Req1,ST1);
fval
```

```
fval =
    1.1327
```

The tracking requirement is nearly met, but the value exceeds 1, indicating a small violation. To further assess the violation, you can use `viewGoal` to visualize the requirement against the corresponding response of the tuned system.

Input Arguments

Req — Tuning goal to evaluate

`TuningGoal` object | vector of `TuningGoal` objects

Tuning goal to evaluate, specified as a `TuningGoal` object or vector of `TuningGoal` objects. For a list of all `TuningGoal` objects, see “Tuning Goals”.

T — Tuned control system

generalized state-space model | `sITuner` interface object

Tuned control system, specified as a generalized state-space (`genss`) model or an `sLTuner` interface to a Simulink model. `T` is typically the result of using the tuning goal to tune control system parameters with `systune`.

Example: `[T, fSoft, gHard] = systune(T0, SoftReq, HardReq)`, where `T0` is a tunable `genss` model

Example: `[T, fSoft, gHard] = systune(ST0, SoftReq, HardReq)`, where `ST0` is a `sLTuner` interface object

Output Arguments

Hspec — transfer function associated with tuning goal

state-space model

Transfer function associated with the tuning goal, returned as a state-space (`ss`) model. `evalGoal` uses `Hspec` to compute the evaluated tuning goal, `fval`.

For example, suppose `Req` is a `TuningGoal.Gain` goal that limits the gain $H(s)$ between some specified input and output to the gain profile $w(s)$. In that case, `Hspec` is given by:

$$Hspec(s) = \frac{1}{w(s)}H(s).$$

`fval` is the peak gain of `Hspec`. If $H(s)$ satisfies the tuning goal, `fval` ≤ 1 .

For more information about the transfer function associated with the tuning goal, see the reference page for each tuning goal.

fval — Normalized value of tuning requirement

positive scalar

Normalized value of tuning requirement, returned as a positive scalar. The normalized value is a measure of how closely the requirement is met in the tuned system. The tuning requirement is satisfied if `fval` < 1 . For information about how each type of `TuningGoal` requirement is converted into a normalized value, see the reference page for each tuning goal.

Tips

- For MIMO feedback loops, the `LoopShape`, `MinLoopGain`, `MaxLoopGain`, `Margins`, `Sensitivity`, and `Rejection` goals are sensitive to the relative scaling of each SISO loop. `systune` tries to balance the overall loop-transfer matrix while enforcing such goals. The optimal loop scaling is stored in the tuned closed-loop model or `sLTuner` interface `T` returned by `systune`. For consistency, `evalGoal(R, T)` applies this same scaling when evaluating the tuning goals. To omit this scaling, use `evalGoal(R, clearTuningInfo(T))`.

Modifying `T` might compromise the validity of the stored scaling. Therefore, if you make significant modifications to `T`, retuning is recommended to update the scaling data.

Version History

Introduced in R2012b

See Also

systeme | genss | viewGoal | systune (for sLTuner)

Topics

“Visualize Tuning Goals”
“Tuning Goals”

evalSpec

(Not recommended) Evaluate tuning goals for tuned control system

Note evalSpec is not recommended. Use evalGoal instead.

Syntax

```
[Hspec, fval] = evalSpec(Req,T)
[Hspec, fval] = evalSpec(Req,T,[])
```

Description

[Hspec, fval] = evalSpec(Req,T) returns the normalized value fval of a tuning goal evaluated for a tuned control system T. The evalSpec command also returns the transfer function Hspec used to compute this value.

[Hspec, fval] = evalSpec(Req,T,[]) disregards scaling information stored with the tuned control system T when evaluating the tuning goal. For more information, see “Tips” on page 2-255.

Examples

Evaluate Requirements for Tuned System

Tune a control system with systune, and evaluate the tuning goals with evalSpec.

Open the Simulink® model rct_airframe2.

```
open_system('rct_airframe2')
```

Create tracking, roll-off, stability margin, and disturbance rejection requirements for tuning the control system.

```
Req1 = TuningGoal.Tracking('az_ref','az',1);
Req2 = TuningGoal.Gain('delta_fin','delta_fin',tf(25,[1 0]));
Req3 = TuningGoal.Margins('delta_fin',7,45);
MaxGain = frd([2 200 200],[0.02 2 200]);
Req4 = TuningGoal.Gain('delta_fin','az',MaxGain);
```

Create an sLTuner interface, and tune the model using these tuning goals.

```
ST0 = sLTuner('rct_airframe2','MIMO Controller');
rng default
[ST1,fSoft] = systune(ST0,[Req1,Req2,Req3,Req4]);
```

```
Final: Soft = 1.13, Hard = -Inf, Iterations = 68
```

ST1 is a tuned version of the sLTuner interface to the control system. ST1 contains the tuned values of the tunable parameters of the MIMO controller in the model.

Evaluate the margin goal for the tuned system.

```
[hspec,fval] = evalSpec(Req3,ST1);  
fval
```

```
fval =  
  
    0.5140
```

The normalized value of the tuning goal is less than 1, indicating that the tuned system satisfies the margin requirement. For more information about how the normalized value of this tuning goal is calculated, see the `TuningGoal.Margins` reference page.

Evaluate the tracking goal for the tuned system.

```
[hspec,fval] = evalSpec(Req1,ST1);  
fval
```

```
fval =  
  
    1.1327
```

The tracking requirement is nearly met, but the value exceeds 1, indicating a small violation. To further assess the violation, you can use `viewSpec` to visualize the requirement against the corresponding response of the tuned system.

Input Arguments

Req — Tuning goal to evaluate

`TuningGoal` object | vector of `TuningGoal` objects

Tuning goal to evaluate, specified as a `TuningGoal` object or vector of `TuningGoal` objects. For a list of all `TuningGoal` objects, see “Tuning Goals”.

T — Tuned control system

generalized state-space model | `sLTuner` interface object

Tuned control system, specified as a generalized state-space (`genss`) model or an `sLTuner` interface to a Simulink model. `T` is typically the result of using the tuning goal to tune control system parameters with `systune`.

Example: `[T,fSoft,gHard] = systune(T0,SoftReq,HardReq)`, where `T0` is a tunable `genss` model

Example: `[T,fSoft,gHard] = systune(ST0,SoftReq,HardReq)`, where `ST0` is a `sLTuner` interface object

Output Arguments

Hspec — transfer function associated with tuning goal

state-space model

Transfer function associated with the tuning goal, returned as a state-space (`ss`) model. `evalSpec` uses `Hspec` to compute the evaluated tuning goal, `fval`.

For example, suppose `Req` is a `TuningGoal.Gain` goal that limits the gain $H(s)$ between some specified input and output to the gain profile $w(s)$. In that case, `Hspec` is given by:

$$Hspec(s) = \frac{1}{w(s)}H(s).$$

`fval` is the peak gain of `Hspec`. If $H(s)$ satisfies the tuning goal, `fval` ≤ 1 .

For more information about the transfer function associated with the tuning goal, see the reference page for each tuning goal.

fval — Normalized value of tuning requirement

positive scalar

Normalized value of tuning requirement, returned as a positive scalar. The normalized value is a measure of how closely the requirement is met in the tuned system. The tuning requirement is satisfied if `fval` < 1 . For information about how each type of `TuningGoal` requirement is converted into a normalized value, see the reference page for each tuning goal.

Tips

- For MIMO feedback loops, the `LoopShape`, `MinLoopGain`, `MaxLoopGain`, `Margins`, `Sensitivity`, and `Rejection` goals are sensitive to the relative scaling of each SISO loop. `systune` tries to balance the overall loop-transfer matrix while enforcing such goals. The optimal loop scaling is stored in the tuned closed-loop model `CL` returned by `systune`. For consistency, `evalSpec(R, CL)` applies this same scaling when evaluating the tuning goals. To omit this scaling, use `evalSpec(R, CL, [])`.

Modifying `CL` might compromise the validity of the stored scaling. Therefore, if you make significant modifications to `CL`, retuning is recommended to update the scaling data.

Version History

Introduced in R2012b

evalSpec is not recommended

Not recommended starting in R2017b

Beginning in R2017b, `evalSpec` is not recommended. Use `evalGoal` instead.

See Also

`systune` | `genss` | `evalGoal` | `viewGoal` | `systune` (for `slTuner`)

Topics

“Visualize Tuning Goals”

“Tuning Goals”

evalSurf

Evaluate gain surfaces at specific design points

Syntax

```
GV = evalSurf(GS,X)
GV = evalSurf(GS,X1,...,XM)
GV = evalSurf( __ ,gridflag)
```

Description

`GV = evalSurf(GS,X)` evaluates a gain surface at the list of points specified in the array `X`. A point is a combination of scheduling-variable values. Thus `X` is an N -by- M array, where N is the number of points at which to evaluate the gain, and M is the number of scheduling variables in `GS`.

`GV = evalSurf(GS,X1,...,XM)` evaluates the gain surface over the rectangular grid generated by the vectors `X1,...,XM`. Each vector contains values for one scheduling variable of `GS`.

`GV = evalSurf(__ ,gridflag)` specifies the layout of `GV`.

Examples

Evaluate 1-D Gain Surface at Specified Values

Create a gain surface with one scheduling variable and evaluate the gain at a list of scheduling-variable values.

When you create a gain surface using `tunableSurface`, you specify design points at which the gain coefficients are tuned. These points are typically the scheduling-variable values at which you have sampled or linearized the plant. However, you might want to implement the gain surface as a lookup table with breakpoints that are different from the specified design points. In this example, you create a gain surface with a set of design points and then evaluate the surface using a different set of scheduling variable values.

Create a scalar gain that varies as a quadratic function of one scheduling variable, t . Suppose that you have linearized your plant every five seconds from $t = 0$ to $t = 40$.

```
t = 0:5:40;
domain = struct('t',t);
shapefcn = @(x) [x,x^2];
GS = tunableSurface('GS',1,domain,shapefcn);
```

Typically, you would tune the coefficients as part of a control system. For this example, instead of tuning, manually set the coefficients to non-zero values.

```
GS = setData(GS,[12.1,4.2,2]);
```

Evaluate the gain surface at a different set of time values.

```

tvals = [0,4,11,18,25,32,39,42]; % eight values
GV = evalSurf(GS,tvals)

GV = 8×1

    9.9000
   10.0200
   10.6150
   11.7000
   13.2750
   15.3400
   17.8950
   19.1400

```

GV is an 8-by-1 array. You can use `tvals` and `GV` to implement the variable gain as a lookup table.

Evaluate Gain Surface on Grid of Values

Evaluate a gain surface with two scheduling variables over a grid of values of those variables.

When you create a gain surface using `tunableSurface`, you specify design points at which the gain coefficients are tuned. These points are typically the scheduling-variable values at which you have sampled or linearized the plant. However, you might want to implement the gain surface as a lookup table with breakpoints that are different from the specified design points. In this example, you create a gain surface with a set of design points and then evaluate the surface using a different set of scheduling-variable values.

Create a scalar-valued gain surface that is a bilinear function of two independent variables, α and V .

```

[alpha,V] = ndgrid(0:1.5:15,300:30:600);
domain = struct('alpha',alpha,'V',V);
shapefcn = @(x,y) [x,y,x*y];
GS = tunableSurface('GS',1,domain,shapefcn);

```

Typically, you would tune the coefficients as part of a control system. For this example, instead of tuning, manually set the coefficients to non-zero values.

```
GS = setData(GS,[100,28,40,10]);
```

Evaluate the gain at selected values of α and V .

```

alpha_vec = [7:1:13]; % N1 = 7 points
V_vec = [400:25:625]; % N2 = 10 points
GV = evalSurf(GS,alpha_vec,V_vec);

```

The breakpoints at which you evaluate the gain surface need not fall within the range specified by `domain`. However, if you attempt to evaluate the gain too far outside the range used for tuning, the software issues a warning.

The breakpoints also need not be regularly spaced. `evalSurf` evaluates the gain surface over the grid formed by `ndgrid(alpha_vec,V_vec)`. Examine the dimensions of the resulting array.

```
size(GV)
```

```
ans = 1×2
      7    10
```

By default, the grid dimensions $N1$ -by- $N2$ are first in the array, followed by the gain dimensions. GS is scalar-valued gain, so the dimensions of GV are $[7,10,1,1]$, or equivalently $[7,10]$.

The value in each location of GV is the gain evaluated at the corresponding (α_vec, V_vec) pair in the grid. For example, $GV(2,3)$ is the gain evaluated at $(\alpha_vec(2), V_vec(3))$ or $(8,450)$.

Evaluate Array-Valued Gain Surface

Evaluate an array-valued gain surface with two scheduling variables over a grid of values of those variables.

Create a vector-valued gain that has two scheduling variables.

```
[alpha,V] = ndgrid(0:1.5:15,300:30:600);
domain = struct('alpha',alpha,'V',V);
shapefcn = @(x,y) [x,y,x*y];
GS = tunableSurface('GS',ones(2,2),domain,shapefcn);
```

Setting the initial constant coefficient to $\text{ones}(2,2)$ causes `tunableSurface` to generate a 2-by-2 gain matrix. Each entry in that matrix is an independently tunable gain surface that is a bilinear function of two scheduling variables. In other words, the gain surface is given by:

$$GS = K_0 + K_1\alpha + K_2V + K_3\alpha V,$$

where each of the coefficients K_0, \dots, K_3 is itself a 2-by-2 matrix.

Typically, you would tune the coefficients of those gain surfaces as part of a control system. For this example, instead of tuning, manually set the coefficients to non-zero values.

```
K0 = 10*rand(2);
K1 = 10*rand(2);
K2 = 10*rand(2);
K3 = 10*rand(2);
```

The `tunableSurface` object stores array-valued coefficients by concatenating them into a 2-by-8 array (see the `tunableSurface` reference page). Therefore, concatenate these values of K_0, \dots, K_3 to change the coefficients of GS .

```
GS = setData(GS,[K0 K1 K2 K3]);
```

Now evaluate the gain surface at selected values of the scheduling variables.

```
alpha_vec = [7:1:13]; % N1 = 7 points
V_vec = [400:25:625]; % N2 = 10 points
GV = evalSurf(GS,alpha_vec,V_vec,'gridlast');
```

The `'gridlast'` orders the array GV such that the dimensions of the grid of gain values, 7-by-10, are last. The dimensions of the gain array itself, 2-by-2, are first.

```
size(GV)
ans = 1×4
     2     2     7    10
```

Input Arguments

GS — Gain surface

tunableSurface object

Gain surface to evaluate, specified as a `tunableSurface` object. GS can have any number of scheduling variables, and can be scalar-valued or array-valued.

X — Points

array

Points at which to evaluate the gain surface, specified as an array. A point is a combination of scheduling-variable values. X has dimensions N -by- M , where M is the number of scheduling variables in GS and N is the number of points at which to evaluate GS. Thus, X is a list of scheduling-variable-value combinations at which to evaluate the gain. For example, suppose GS has two scheduling variables, a and b, and you want to evaluate GS at 10 (a,b) pairs. In that case, X is a 10-by-2 array that lists the (a,b). The points in X need not match the design points in `GS.SamplingGrid`.

X1, ..., XM — Scheduling-variable values

arrays

Scheduling-variable values at which to evaluate the gain surface, specified as M arrays, where M is the number of scheduling variables in GS. For example, if GS has two scheduling variables, a and b, then X1 and X2 are vectors of a and b values, respectively. The gain surface is evaluated over the grid `ndgrid(X1,X2)`. The values in that grid need not match the design points in `GS.SamplingGrid`.

gridflag — Layout of output array

'gridfirst' (default) | 'gridlast'

Layout of output array, specified as either 'gridfirst' or 'gridlast'.

- 'gridfirst' — GV is of size $[N1, \dots, NM, Ny, Nu]$ with the grid dimensions first and the gain dimensions last. This layout is the natural format for a scalar gain, where $Ny = Nu = 1$.
- 'gridlast' — GV is of size $[Ny, Nu, N1, \dots, NM]$ with the gain dimensions first. This format is more readable for matrix-valued gains.

Output Arguments

GV — Gain values

array

Gain values, returned as an array. GV contains the gain evaluated at the points (scheduling-variable values) specified by X or X1, ..., XM. The size of GV depends on the number of scheduling variables in GS, the I/O dimensions of the gain defined by GS, and the value of `gridflag`.

If you compute the gain at a list of N points specified in an array X, then the size of GV is $[N, Ny, Nu]$. Here, $[Ny, Nu]$ are the I/O dimensions of the gain. For example, suppose GS is a scalar gain surface

with two scheduling variables, **a** and **b**, and **X** is a 10-by-2 array containing 10 (**a**, **b**) pairs. Then **GV** is a column vector of ten values.

If you compute the gain over a grid specified by vectors **X1**, ..., **XM**, then the dimensions of **GV** depend on the value of **gridflag**.

- **gridflag** = 'gridfirst' (default) — The size of **GV** is [**N1**, ..., **NM**, **Ny**, **Nu**]. Each **Ni** is the length of **Xi**, the number of values of the *i*-th scheduling variable. For example, suppose **GS** is a scalar gain surface with two scheduling variables, **a** and **b**, and **X1** and **X2** are vectors of 4 **a** values and 5 **b** values, respectively. Then, the size of **GV** is [4,5,1,1] or equivalently, [4,5]. Or, if **GS** is a three-output, two-input vector-valued gain, then the size of **GV** is [4,5,3,2].
- **gridflag** = 'gridlast' — The size of **GV** is [**Ny**, **Nu**, **N1**, ..., **NM**]. For example, suppose **GS** is a scalar gain surface with two scheduling variables, **a** and **b**, and **X1** and **X2** are vectors of 4 **a** values and 5 **b** values, respectively. Then, the size of **GV** is [1,1,4,5]. Or, if **GS** is a three-output, two-input vector-valued gain, then the size of **GV** is [3,2,4,5].

Tips

- Use **evalSurf** to turn tuned gain surfaces into lookup tables. Set **X1**, ..., **XM** to the desired table breakpoints and use **GV** as table data. The table breakpoints do not need to match the design points used for tuning **GS**.

Version History

Introduced in **R2015b**

See Also

[tunableSurface](#) | [viewSurf](#) | [getData](#) | [setData](#)

exp

Create pure continuous-time delays

Syntax

```
d = exp(tau,s)
```

Description

`d = exp(tau,s)` creates pure continuous-time delays. The transfer function of a pure delay `tau` is:

$$d(s) = \exp(-\text{tau}*s)$$

You can specify this transfer function using `exp`.

```
s = zpk('s')  
d = exp(-tau*s)
```

More generally, given a 2D array `M`,

```
s = zpk('s')  
D = exp(-M*s)
```

creates an array `D` of pure delays where

$$D(i,j) = \exp(-M(i,j)s).$$

All entries of `M` should be non negative for causality.

Version History

Introduced in R2006a

See Also

`zpk` | `tf`

extendedKalmanFilter

Create extended Kalman filter object for online state estimation

Syntax

```
obj = extendedKalmanFilter(StateTransitionFcn,MeasurementFcn,InitialState)
obj = extendedKalmanFilter(StateTransitionFcn,MeasurementFcn,InitialState,
Name,Value)
```

```
obj = extendedKalmanFilter(StateTransitionFcn,MeasurementFcn)
obj = extendedKalmanFilter(StateTransitionFcn,MeasurementFcn,Name,Value)
obj = extendedKalmanFilter(Name,Value)
```

Description

`obj = extendedKalmanFilter(StateTransitionFcn,MeasurementFcn,InitialState)` creates an extended Kalman filter object for online state estimation of a discrete-time nonlinear system. `StateTransitionFcn` is a function that calculates the state of the system at time k , given the state vector at time $k-1$. `MeasurementFcn` is a function that calculates the output measurement of the system at time k , given the state at time k . `InitialState` specifies the initial value of the state estimates.

After creating the object, use the `correct` and `predict` commands to update state estimates and state estimation error covariance values using a first-order discrete-time extended Kalman filter algorithm and real-time data.

`obj = extendedKalmanFilter(StateTransitionFcn,MeasurementFcn,InitialState,Name,Value)` specifies additional attributes of the extended Kalman filter object using one or more `Name,Value` pair arguments.

`obj = extendedKalmanFilter(StateTransitionFcn,MeasurementFcn)` creates an extended Kalman filter object using the specified state transition and measurement functions. Before using the `predict` and `correct` commands, specify the initial state values using dot notation. For example, for a two-state system with initial state values $[1;0]$, specify `obj.State = [1;0]`.

`obj = extendedKalmanFilter(StateTransitionFcn,MeasurementFcn,Name,Value)` specifies additional attributes of the extended Kalman filter object using one or more `Name,Value` pair arguments. Before using the `predict` and `correct` commands, specify the initial state values using `Name,Value` pair arguments or dot notation.

`obj = extendedKalmanFilter(Name,Value)` creates an extended Kalman filter object with properties specified using one or more `Name,Value` pair arguments. Before using the `predict` and `correct` commands, specify the state transition function, measurement function, and initial state values using `Name,Value` pair arguments or dot notation.

Object Description

`extendedKalmanFilter` creates an object for online state estimation of a discrete-time nonlinear system using the first-order discrete-time extended Kalman filter algorithm.

Consider a plant with states x , input u , output y , process noise w , and measurement noise v . Assume that you can represent the plant as a nonlinear system.

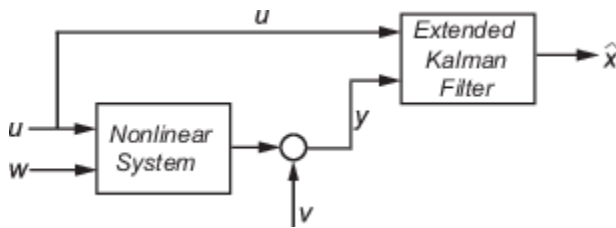

The algorithm computes the state estimates \hat{x} of the nonlinear system using state transition and measurement functions specified by you. The software lets you specify the noise in these functions as additive or nonadditive:

- **Additive Noise Terms** — The state transition and measurements equations have the following form:

$$\begin{aligned}x[k] &= f(x[k-1], u_s[k-1]) + w[k-1] \\y[k] &= h(x[k], u_m[k]) + v[k]\end{aligned}$$

Here f is a nonlinear state transition function that describes the evolution of states x from one time step to the next. The nonlinear measurement function h relates x to the measurements y at time step k . w and v are the zero-mean, uncorrelated process and measurement noises, respectively. These functions can also have additional input arguments that are denoted by u_s and u_m in the equations. For example, the additional arguments could be time step k or the inputs u to the nonlinear system. There can be multiple such arguments.

Note that the noise terms in both equations are additive. That is, $x(k)$ is linearly related to the process noise $w(k-1)$, and $y(k)$ is linearly related to the measurement noise $v(k)$.

- **Nonadditive Noise Terms** — The software also supports more complex state transition and measurement functions where the state $x[k]$ and measurement $y[k]$ are nonlinear functions of the process noise and measurement noise, respectively. When the noise terms are nonadditive, the state transition and measurements equation have the following form:

$$\begin{aligned}x[k] &= f(x[k-1], w[k-1], u_s[k-1]) \\y[k] &= h(x[k], v[k], u_m[k])\end{aligned}$$

When you perform online state estimation, you first create the nonlinear state transition function f and measurement function h . You then construct the `extendedKalmanFilter` object using these nonlinear functions, and specify whether the noise terms are additive or nonadditive. You can also specify the Jacobians of the state transition and measurement functions. If you do not specify them, the software numerically computes the Jacobians.

After you create the object, you use the `predict` command to predict state estimate at the next time step, and `correct` to correct state estimates using the algorithm and real-time data. For information about the algorithm, see “Extended and Unscented Kalman Filter Algorithms for Online State Estimation”.

You can use the following commands with `extendedKalmanFilter` objects:

Command	Description
<code>correct</code>	Correct the state and state estimation error covariance at time step k using measured data at time step k .
<code>predict</code>	Predict the state and state estimation error covariance at time the next time step.
<code>residual</code>	Return the difference between the actual and predicted measurements.
<code>clone</code>	Create another object with the same object property values. Do not create additional objects using syntax <code>obj2 = obj</code> . Any changes made to the properties of the new object created in this way (<code>obj2</code>) also change the properties of the original object (<code>obj</code>).

For `extendedKalmanFilter` object properties, see “Properties” on page 2-269.

Examples

Create Extended Kalman Filter Object for Online State Estimation

To define an extended Kalman filter object for estimating the states of your system, you first write and save the state transition function and measurement function for the system.

In this example, use the previously written and saved state transition and measurement functions, `vdpStateFcn.m` and `vdpMeasurementFcn.m`. These functions describe a discrete-approximation to a van der Pol oscillator with nonlinearity parameter, μ , equal to 1. The oscillator has two states.

Specify an initial guess for the two states. You specify the guess as an M -element row or column vector, where M is the number of states.

```
initialStateGuess = [1;0];
```

Create the extended Kalman filter object. Use function handles to provide the state transition and measurement functions to the object.

```
obj = extendedKalmanFilter(@vdpStateFcn,@vdpMeasurementFcn,initialStateGuess);
```

The object has a default structure where the process and measurement noise are additive.

To estimate the states and state estimation error covariance from the constructed object, use the `correct` and `predict` commands and real-time data.

Specify Process and Measurement Noise Covariances in Extended Kalman Filter Object

Create an extended Kalman filter object for a van der Pol oscillator with two states and one output. Use the previously written and saved state transition and measurement functions, `vdpStateFcn.m`

and `vdpMeasurementFcn.m`. These functions are written for additive process and measurement noise terms. Specify the initial state values for the two states as `[2;0]`.

Since the system has two states and the process noise is additive, the process noise is a 2-element vector and the process noise covariance is a 2-by-2 matrix. Assume there is no cross-correlation between process noise terms, and both the terms have the same variance 0.01. You can specify the process noise covariance as a scalar. The software uses the scalar value to create a 2-by-2 diagonal matrix with 0.01 on the diagonals.

Specify the process noise covariance during object construction.

```
obj = extendedKalmanFilter(@vdpStateFcn,@vdpMeasurementFcn,[2;0],...
    'ProcessNoise',0.01);
```

Alternatively, you can specify noise covariances after object construction using dot notation. For example, specify the measurement noise covariance as 0.2.

```
obj.MeasurementNoise = 0.2;
```

Since the system has only one output, the measurement noise is a 1-element vector and the `MeasurementNoise` property denotes the variance of the measurement noise.

Specify Jacobians for State and Measurement Functions

Create an extended Kalman filter object for a van der Pol oscillator with two states and one output. Use the previously written and saved state transition and measurement functions, `vdpStateFcn.m` and `vdpMeasurementFcn.m`. Specify the initial state values for the two states as `[2;0]`.

```
obj = extendedKalmanFilter(@vdpStateFcn,@vdpMeasurementFcn,[2;0]);
```

The extended Kalman filter algorithm uses Jacobians of the state transition and measurement functions for state estimation. You write and save the Jacobian functions and provide them as function handles to the object. In this example, use the previously written and saved functions `vdpStateJacobianFcn.m` and `vdpMeasurementJacobianFcn.m`.

```
obj.StateTransitionJacobianFcn = @vdpStateJacobianFcn;
obj.MeasurementJacobianFcn = @vdpMeasurementJacobianFcn;
```

Note that if you do not specify the Jacobians of the functions, the software numerically computes the Jacobians. This numerical computation may result in increased processing time and numerical inaccuracy of the state estimation.

Specify Nonadditive Measurement Noise in Extended Kalman Filter Object

Create an extended Kalman filter object for a van der Pol oscillator with two states and one output. Assume that the process noise terms in the state transition function are additive. That is, there is a linear relation between the state and process noise. Also assume that the measurement noise terms are nonadditive. That is, there is a nonlinear relation between the measurement and measurement noise.

```
obj = extendedKalmanFilter('HasAdditiveMeasurementNoise',false);
```

Specify the state transition function and measurement functions. Use the previously written and saved functions, `vdpStateFcn.m` and `vdpMeasurementNonAdditiveNoiseFcn.m`.

The state transition function is written assuming the process noise is additive. The measurement function is written assuming the measurement noise is nonadditive.

```
obj.StateTransitionFcn = @vdpStateFcn;
obj.MeasurementFcn = @vdpMeasurementNonAdditiveNoiseFcn;
```

Specify the initial state values for the two states as `[2;0]`.

```
obj.State = [2;0];
```

You can now use the `correct` and `predict` commands to estimate the state and state estimation error covariance values from the constructed object.

Specify State Transition and Measurement Functions with Additional Inputs

Consider a nonlinear system with input u whose state x and measurement y evolve according to the following state transition and measurement equations:

$$x[k] = \sqrt{x[k-1] + u[k-1]} + w[k-1]$$

$$y[k] = x[k] + 2 * u[k] + v[k]^2$$

The process noise w of the system is additive while the measurement noise v is nonadditive.

Create the state transition function and measurement function for the system. Specify the functions with an additional input u .

```
f = @(x,u)(sqrt(x+u));
h = @(x,v,u)(x+2*u+v^2);
```

`f` and `h` are function handles to the anonymous functions that store the state transition and measurement functions, respectively. In the measurement function, because the measurement noise is nonadditive, v is also specified as an input. Note that v is specified as an input before the additional input u .

Create an extended Kalman filter object for estimating the state of the nonlinear system using the specified functions. Specify the initial value of the state as 1 and the measurement noise as nonadditive.

```
obj = extendedKalmanFilter(f,h,1,'HasAdditiveMeasurementNoise',false);
```

Specify the measurement noise covariance.

```
obj.MeasurementNoise = 0.01;
```

You can now estimate the state of the system using the `predict` and `correct` commands. You pass the values of u to `predict` and `correct`, which in turn pass them to the state transition and measurement functions, respectively.

Correct the state estimate with measurement $y[k]=0.8$ and input $u[k]=0.2$ at time step k .

```
correct(obj,0.8,0.2)
```

Predict the state at the next time step, given $u[k]=0.2$.

```
predict(obj,0.2)
```

Retrieve the error, or *residual*, between the prediction and the measurement.

```
[Residual, ResidualCovariance] = residual(obj,0.8,0.2);
```

Input Arguments

StateTransitionFcn — State transition function

function handle

State transition function f , specified as a function handle. The function calculates the N_s -element state vector of the system at time step k , given the state vector at time step $k-1$. N_s is the number of states of the nonlinear system.

You write and save the state transition function for your nonlinear system, and use it to construct the object. For example, if `vdpStateFcn.m` is the state transition function, specify `StateTransitionFcn` as `@vdpStateFcn`. You can also specify `StateTransitionFcn` as a function handle to an anonymous function.

The inputs to the function you write depend on whether you specify the process noise as additive or nonadditive in the `HasAdditiveProcessNoise` property of the object:

- `HasAdditiveProcessNoise` is true — The process noise w is additive, and the state transition function specifies how the states evolve as a function of state values at the previous time step:

$$x(k) = f(x(k-1), Us1, \dots, Usn)$$

Where $x(k)$ is the estimated state at time k , and $Us1, \dots, Usn$ are any additional input arguments required by your state transition function, such as system inputs or the sample time. During estimation, you pass these additional arguments to the `predict` command, which in turn passes them to the state transition function.

- `HasAdditiveProcessNoise` is false — The process noise is nonadditive, and the state transition function also specifies how the states evolve as a function of the process noise:

$$x(k) = f(x(k-1), w(k-1), Us1, \dots, Usn)$$

To see an example of a state transition function with additive process noise, type `edit vdpStateFcn` at the command line.

MeasurementFcn — Measurement function

function handle

Measurement function h , specified as a function handle. The function calculates the N -element output measurement vector of the nonlinear system at time step k , given the state vector at time step k . N is the number of measurements of the system. You write and save the measurement function, and use it to construct the object. For example, if `vdpMeasurementFcn.m` is the measurement function, specify `MeasurementFcn` as `@vdpMeasurementFcn`. You can also specify `MeasurementFcn` as a function handle to an anonymous function.

The inputs to the function depend on whether you specify the measurement noise as additive or nonadditive in the `HasAdditiveMeasurementNoise` property of the object:

- `HasAdditiveMeasurementNoise` is true — The measurement noise v is additive, and the measurement function specifies how the measurements evolve as a function of state values:

$$y(k) = h(x(k), Um1, \dots, Umn)$$

Where $y(k)$ and $x(k)$ are the estimated output and estimated state at time k , and $Um1, \dots, Umn$ are any optional input arguments required by your measurement function. For example, if you are using multiple sensors for tracking an object, an additional input could be the sensor position. During estimation, you pass these additional arguments to the `correct` command, which in turn passes them to the measurement function.

- `HasAdditiveMeasurementNoise` is false — The measurement noise is nonadditive, and the measurement function also specifies how the output measurement evolves as a function of the measurement noise:

$$y(k) = h(x(k), v(k), Um1, \dots, Umn)$$

When you have the `HasMeasurementWrapping` property enabled, then the output for the measurement function must also include the wrapping bounds, specified as an N -by-2 matrix where, the first column provides the minimum measurement bound and the second column provides the maximum measurement bound. N is the number of measurements of the system.

To see an example of a measurement function with additive process noise, type `edit vdpMeasurementFcn` at the command line. To see an example of a measurement function with nonadditive process noise, type `edit vdpMeasurementNonAdditiveNoiseFcn`.

InitialState — Initial state estimate value

vector

Initial state estimate value, specified as an N_s -element vector, where N_s is the number of states in the system. Specify the initial state values based on your knowledge of the system.

The specified value is stored in the `State` property of the object. If you specify `InitialState` as a column vector, then `State` is also a column vector, and the `predict` and `correct` commands return state estimates as a column vector. Otherwise, a row vector is returned.

If you want a filter with single-precision floating-point variables, specify `InitialState` as a single-precision vector variable. For example, for a two-state system with state transition and measurement functions `vdpStateFcn.m` and `vdpMeasurementFcn.m`, create the extended Kalman filter object with initial state estimates `[1;2]` as follows:

```
obj = extendedKalmanFilter(@vdpStateFcn,@vdpMeasurementFcn,single([1;2]))
```

Data Types: `double` | `single`

Name-Value Pair Arguments

Specify optional pairs of arguments as `Name1=Value1, ..., NameN=ValueN`, where `Name` is the argument name and `Value` is the corresponding value. Name-value arguments must appear after other arguments, but the order of the pairs does not matter.

Before R2021a, use commas to separate each name and value, and enclose Name in quotes.

Use `Name`, `Value` arguments to specify properties on page 2-269 of `extendedKalmanFilter` object during object creation. For example, to create an extended Kalman filter object and specify the process noise covariance as 0.01:

```
obj = extendedKalmanFilter(StateTransitionFcn,MeasurementFcn,InitialState, 'ProcessNoise',0.01);
```

Properties

`extendedKalmanFilter` object properties are of three types:

- Tunable properties that you can specify multiple times, either during object construction using `Name`, `Value` arguments, or any time afterward during state estimation. After object creation, use dot notation to modify the tunable properties.

```
obj = extendedKalmanFilter(StateTransitionFcn,MeasurementFcn,InitialState);
obj.ProcessNoise = 0.01;
```

The tunable properties are `State`, `StateCovariance`, `ProcessNoise`, and `MeasurementNoise`.

- Nontunable properties that you can specify once, either during object construction or afterward using dot notation. Specify these properties before state estimation using `correct` and `predict`. The `StateTransitionFcn`, `MeasurementFcn`, `StateTransitionJacobianFcn`, and `MeasurementJacobianFcn` properties belong to this category.
- Nontunable properties that you must specify during object construction. The `HasAdditiveProcessNoise` and `HasAdditiveMeasurementNoise` properties belong to this category.

HasAdditiveMeasurementNoise — Measurement noise characteristics

`true` (default) | `false`

Measurement noise characteristics, specified as one of the following values:

- `true` — Measurement noise v is additive. The measurement function h that is specified in `MeasurementFcn` has the following form:

$$y(k) = h(x(k), U_{m1}, \dots, U_{mn})$$

Where $y(k)$ and $x(k)$ are the estimated output and estimated state at time k , and U_{m1}, \dots, U_{mn} are any optional input arguments required by your measurement function.

- `false` — Measurement noise is nonadditive. The measurement function specifies how the output measurement evolves as a function of the state *and* measurement noise:

$$y(k) = h(x(k), v(k), U_{m1}, \dots, U_{mn})$$

`HasAdditiveMeasurementNoise` is a nontunable property, and you can specify it only during object construction. You cannot change it using dot notation.

HasAdditiveProcessNoise — Process noise characteristics

`true` (default) | `false`

Process noise characteristics, specified as one of the following values:

- `true` — Process noise w is additive. The state transition function f specified in `StateTransitionFcn` has the following form:

$$x(k) = f(x(k-1), Us1, \dots, Usn)$$

Where $x(k)$ is the estimated state at time k , and $Us1, \dots, Usn$ are any additional input arguments required by your state transition function.

- `false` — Process noise is nonadditive. The state transition function specifies how the states evolve as a function of the state *and* process noise at the previous time step:

$$x(k) = f(x(k-1), w(k-1), Us1, \dots, Usn)$$

`HasAdditiveProcessNoise` is a nontunable property, and you can specify it only during object construction. You cannot change it using dot notation.

MeasurementFcn — Measurement function

function handle

Measurement function h , specified as a function handle. The function calculates the N -element output measurement vector of the nonlinear system at time step k , given the state vector at time step k . N is the number of measurements of the system. You write and save the measurement function and use it to construct the object. For example, if `vdpMeasurementFcn.m` is the measurement function, specify `MeasurementFcn` as `@vdpMeasurementFcn`. You can also specify `MeasurementFcn` as a function handle to an anonymous function.

The inputs to the function depend on whether you specify the measurement noise as additive or nonadditive in the `HasAdditiveMeasurementNoise` property of the object:

- `HasAdditiveMeasurementNoise` is true — The measurement noise v is additive, and the measurement function specifies how the measurements evolve as a function of state values:

$$y(k) = h(x(k), Um1, \dots, Umn)$$

Where $y(k)$ and $x(k)$ are the estimated output and estimated state at time k , and $Um1, \dots, Umn$ are any optional input arguments required by your measurement function. For example, if you are using multiple sensors for tracking an object, an additional input could be the sensor position. During estimation, you pass these additional arguments to the `correct` command which in turn passes them to the measurement function.

- `HasAdditiveMeasurementNoise` is false — The measurement noise is nonadditive, and the measurement function also specifies how the output measurement evolves as a function of the measurement noise:

$$y(k) = h(x(k), v(k), Um1, \dots, Umn)$$

When you have the `HasMeasurementWrapping` property enabled, then the output for the measurement function must also include the wrapping bounds, specified as an N -by-2 matrix where, the first column provides the minimum measurement bound and the second column provides the maximum measurement bound. N is the number of measurements of the system.

To see an example of a measurement function with additive process noise, type `edit vdpMeasurementFcn` at the command line. To see an example of a measurement function with nonadditive process noise, type `edit vdpMeasurementNonAdditiveNoiseFcn`.

`MeasurementFcn` is a nontunable property. You can specify it once before using the `correct` command either during object construction or using dot notation after object construction. You cannot change it after using the `correct` command.

MeasurementJacobianFcn — Jacobian of measurement function

[] (default) | function handle

Jacobian of measurement function h , specified as one of the following:

- [] — The Jacobian is numerically computed at every call to the `correct` command. This may increase processing time and numerical inaccuracy of the state estimation.
- function handle — You write and save the Jacobian function and specify the handle to the function. For example, if `vdpMeasurementJacobianFcn.m` is the Jacobian function, specify `MeasurementJacobianFcn` as `@vdpMeasurementJacobianFcn`.

The function calculates the partial derivatives of the measurement function with respect to the states and measurement noise. The number of inputs to the Jacobian function must equal the number of inputs to the measurement function and must be specified in the same order in both functions. The number of outputs of the Jacobian function depends on the `HasAdditiveMeasurementNoise` property:

- `HasAdditiveMeasurementNoise` is true — The function calculates the partial derivatives of the measurement function with respect to the states ($\partial h / \partial x$). The output is as an N -by- N_s Jacobian matrix, where N is the number of measurements of the system and N_s is the number of states.
- `HasAdditiveMeasurementNoise` is false — The function also returns a second output that is the partial derivative of the measurement function with respect to the measurement noise terms ($\partial h / \partial v$). The second output is returned as an N -by- V Jacobian matrix, where V is the number of measurement noise terms.

To see an example of a Jacobian function for additive measurement noise, type `edit vdpMeasurementJacobianFcn` at the command line.

`MeasurementJacobianFcn` is a nontunable property. You can specify it once before using the `correct` command either during object construction or using dot notation after object construction. You cannot change it after using the `correct` command.

MeasurementNoise — Measurement noise covariance

1 (default) | scalar | matrix

Measurement noise covariance, specified as a scalar or matrix depending on the value of the `HasAdditiveMeasurementNoise` property:

- `HasAdditiveMeasurementNoise` is true — Specify the covariance as a scalar or an N -by- N matrix, where N is the number of measurements of the system. Specify a scalar if there is no cross-correlation between measurement noise terms and all the terms have the same variance. The software uses the scalar value to create an N -by- N diagonal matrix.
- `HasAdditiveMeasurementNoise` is false — Specify the covariance as a V -by- V matrix, where V is the number of measurement noise terms. `MeasurementNoise` must be specified before using `correct`. After you specify `MeasurementNoise` as a matrix for the first time, to then change `MeasurementNoise` you can also specify it as a scalar. Specify as a scalar if there is no cross-correlation between the measurement noise terms and all the terms have the same variance. The software extends the scalar to a V -by- V diagonal matrix with the scalar on the diagonals.

`MeasurementNoise` is a tunable property. You can change it using dot notation.

ProcessNoise — Process noise covariance

1 (default) | scalar | matrix

Process noise covariance, specified as a scalar or matrix depending on the value of the `HasAdditiveProcessNoise` property:

- `HasAdditiveProcessNoise` is true — Specify the covariance as a scalar or an N_s -by- N_s matrix, where N_s is the number of states of the system. Specify a scalar if there is no cross-correlation between process noise terms, and all the terms have the same variance. The software uses the scalar value to create an N_s -by- N_s diagonal matrix.
- `HasAdditiveProcessNoise` is false — Specify the covariance as a W -by- W matrix, where W is the number of process noise terms. `ProcessNoise` must be specified before using `predict`. After you specify `ProcessNoise` as a matrix for the first time, to then change `ProcessNoise` you can also specify it as a scalar. Specify as a scalar if there is no cross-correlation between the process noise terms and all the terms have the same variance. The software extends the scalar to a W -by- W diagonal matrix.

`ProcessNoise` is a tunable property. You can change it using dot notation.

State — State of nonlinear system

`[]` (default) | vector

State of the nonlinear system, specified as a vector of size N_s , where N_s is the number of states of the system.

When you use the `predict` command, `State` is updated with the predicted value at time step k using the state value at time step $k-1$. When you use the `correct` command, `State` is updated with the estimated value at time step k using measured data at time step k .

The initial value of `State` is the value you specify in the `InitialState` input argument during object creation. If you specify `InitialState` as a column vector, then `State` is also a column vector, and the `predict` and `correct` commands return state estimates as a column vector. Otherwise, a row vector is returned. If you want a filter with single-precision floating-point variables, you must specify `State` as a single-precision variable during object construction using the `InitialState` input argument.

`State` is a tunable property. You can change it using dot notation.

StateCovariance — State estimation error covariance

1 (default) | scalar | matrix

State estimation error covariance, specified as a scalar or an N_s -by- N_s matrix, where N_s is the number of states of the system. If you specify a scalar, the software uses the scalar value to create an N_s -by- N_s diagonal matrix.

Specify a high value for the covariance when you do not have confidence in the initial state values that you specify in the `InitialState` input argument.

When you use the `predict` command, `StateCovariance` is updated with the predicted value at time step k using the state value at time step $k-1$. When you use the `correct` command, `StateCovariance` is updated with the estimated value at time step k using measured data at time step k .

`StateCovariance` is a tunable property. You can change it using dot notation after using the `correct` or `predict` commands.

StateTransitionFcn — State transition function

function handle

State transition function f , specified as a function handle. The function calculates the N_s -element state vector of the system at time step k , given the state vector at time step $k-1$. N_s is the number of states of the nonlinear system.

You write and save the state transition function for your nonlinear system and use it to construct the object. For example, if `vdpStateFcn.m` is the state transition function, specify `StateTransitionFcn` as `@vdpStateFcn`. You can also specify `StateTransitionFcn` as a function handle to an anonymous function.

The inputs to the function you write depend on whether you specify the process noise as additive or nonadditive in the `HasAdditiveProcessNoise` property of the object:

- `HasAdditiveProcessNoise` is true — The process noise w is additive, and the state transition function specifies how the states evolve as a function of state values at previous time step:

$$x(k) = f(x(k-1), Us1, \dots, Usn)$$

Where $x(k)$ is the estimated state at time k , and $Us1, \dots, Usn$ are any additional input arguments required by your state transition function, such as system inputs or the sample time. During estimation, you pass these additional arguments to the `predict` command, which in turn passes them to the state transition function.

- `HasAdditiveProcessNoise` is false — The process noise is nonadditive, and the state transition function also specifies how the states evolve as a function of the process noise:

$$x(k) = f(x(k-1), w(k-1), Us1, \dots, Usn)$$

To see an example of a state transition function with additive process noise, type `edit vdpStateFcn` at the command line.

`StateTransitionFcn` is a nontunable property. You can specify it once before using the `predict` command either during object construction or using dot notation after object construction. You cannot change it after using the `predict` command.

StateTransitionJacobianFcn — Jacobian of state transition function

`[]` (default) | function handle

Jacobian of state transition function f , specified as one of the following:

- `[]` — The Jacobian is numerically computed at every call to the `predict` command. This may increase processing time and numerical inaccuracy of the state estimation.
- function handle — You write and save the Jacobian function and specify the handle to the function. For example, if `vdpStateJacobianFcn.m` is the Jacobian function, specify `StateTransitionJacobianFcn` as `@vdpStateJacobianFcn`.

The function calculates the partial derivatives of the state transition function with respect to the states and process noise. The number of inputs to the Jacobian function must equal the number of inputs of the state transition function and must be specified in the same order in both functions. The number of outputs of the function depends on the `HasAdditiveProcessNoise` property:

- `HasAdditiveProcessNoise` is true — The function calculates the partial derivative of the state transition function with respect to the states ($\partial f / \partial x$). The output is an N_s -by- N_s Jacobian matrix, where N_s is the number of states.
- `HasAdditiveProcessNoise` is false — The function must also return a second output that is the partial derivative of the state transition function with respect to the process noise terms

($\partial f / \partial w$). The second output is returned as an N s-by- W Jacobian matrix, where W is the number of process noise terms.

The extended Kalman filter algorithm uses the Jacobian to compute the state estimation error covariance.

To see an example of a Jacobian function for additive process noise, type `edit vdpStateJacobianFcn` at the command line.

`StateTransitionJacobianFcn` is a nontunable property. You can specify it once before using the `predict` command either during object construction or using dot notation after object construction. You cannot change it after using the `predict` command.

HasMeasurementWrapping — Enable measurement wrapping

0 (default) | 1

Enable measurement wrapping, specified as either 0 or 1. You can enable measurement wrapping to estimate states when you have circular measurements that are independent of your model states. If you select this parameter, then the measurement function you specify must include the following two outputs:

- 1 The measurement, specified as a N -element output measurement vector of the nonlinear system at time step k , given the state vector at time step k . N is the number of measurements of the system.
- 2 The measurement wrapping bounds, specified as an N -by-2 matrix where, the first column provides the minimum measurement bound and the second column provides the maximum measurement bound.

Enabling the `HasMeasurementWrapping` property wraps the measurement residuals in a defined bound, which helps to prevent the filter from divergence due to incorrect measurement residual values. For an example, see “State Estimation with Wrapped Measurements Using Extended Kalman Filter”.

`HasMeasurementWrapping` is a nontunable property. You can specify it once during the object construction. You cannot change it after creating the state estimation object.

Output Arguments

obj — Extended Kalman filter object for online state estimation

`extendedKalmanFilter` object

Extended Kalman filter object for online state estimation, returned as an `extendedKalmanFilter` object. This object is created using the specified properties on page 2-269. Use the `correct` and `predict` commands to estimate the state and state estimation error covariance using the extended Kalman filter algorithm.

When you use `predict`, `obj.State` and `obj.StateCovariance` are updated with the predicted value at time step k using the state value at time step $k-1$. When you use `correct`, `obj.State` and `obj.StateCovariance` are updated with the estimated values at time step k using measured data at time step k .

Version History

Introduced in R2016b

Numerical Changes

Behavior changed in R2020b

Starting in R2020b, numerical improvements in the `extendedKalmanFilter` algorithm might produce results that are different from the results you obtained in previous versions.

Extended Capabilities

C/C++ Code Generation

Generate C and C++ code using MATLAB® Coder™.

Usage notes and limitations:

For more information, see “Generate Code for Online State Estimation in MATLAB”.

Generated code uses an algorithm that is different from the algorithm that the `extendedKalmanFilter` function uses. You might see some numerical differences in the results obtained using the two methods.

Supports MATLAB Function block: No

See Also

Functions

`predict` | `correct` | `residual` | `clone` | `unscentedKalmanFilter` | `kalman` | `kalmd`

Blocks

Kalman Filter | Extended Kalman Filter | Unscented Kalman Filter

Topics

“Nonlinear State Estimation Using Unscented Kalman Filter and Particle Filter”

“Generate Code for Online State Estimation in MATLAB”

“State Estimation with Wrapped Measurements Using Extended Kalman Filter”

“Extended and Unscented Kalman Filter Algorithms for Online State Estimation”

“Validate Online State Estimation at the Command Line”

“Troubleshoot Online State Estimation”

External Websites

Understanding Kalman Filters: Nonlinear State Estimators — MATLAB Video Series

fcat

Concatenate FRD models along frequency dimension

Syntax

```
sys = fcat(sys1,sys2,...)
```

Description

sys = fcat(*sys1*,*sys2*,...) takes two or more frd models and merges their frequency responses into a single frd model *sys*. The resulting frequency vector is sorted by increasing frequency. The frequency vectors of *sys1*, *sys2*, ... should not intersect. If the frequency vectors do intersect, use `fdel` to remove intersecting data from one or more of the models.

Version History

Introduced in R2006a

See Also

`fdel` | `fselect` | `interp` | `frd`

fdel

Delete specified data from frequency response data (FRD) models

Syntax

```
sysout = fdel(sys, freq)
```

Description

sysout = fdel(*sys*, *freq*) removes from the frd model *sys* the data nearest to the frequency values specified in the vector *freq*.

Input Arguments

sys

frd model.

freq

Vector of frequency values.

Output Arguments

sysout

frd model containing the data remaining in *sys* after removing the frequency points closest to the entries of *freq*.

Examples

Delete Specified Data from Frequency Response Data Model

Create a frequency response data (FRD) model at specified frequencies from a transfer function model.

```
w = logspace(0,1,10);
sys = frd(tf([1],[1 1]),w)
```

```
sys =
```

Frequency(rad/s)	Response
-----	-----
1.0000	0.5000 - 0.5000i
1.2915	0.3748 - 0.4841i
1.6681	0.2644 - 0.4410i
2.1544	0.1773 - 0.3819i
2.7826	0.1144 - 0.3183i
3.5938	0.0719 - 0.2583i

```
4.6416      0.0444 - 0.2059i
5.9948      0.0271 - 0.1623i
7.7426      0.0164 - 0.1270i
10.0000     0.0099 - 0.0990i
```

Continuous-time frequency response.

w is a logarithmically-spaced grid of 10 frequency points between 1 and 10 rad/second.

Remove the data nearest 2, 3.5, and 6 rad/s from sys.

```
freq = [2, 3.5, 6];
sys2 = fdel(sys, freq)
```

```
sys2 =
```

Frequency (rad/s)	Response
1.0000	0.5000 - 0.5000i
1.2915	0.3748 - 0.4841i
1.6681	0.2644 - 0.4410i
2.7826	0.1144 - 0.3183i
4.6416	0.0444 - 0.2059i
7.7426	0.0164 - 0.1270i
10.0000	0.0099 - 0.0990i

Continuous-time frequency response.

Note that you do not have to specify the exact frequency of the data to remove. The `fdel` command removes the data corresponding to frequencies that are nearest to the specified frequencies.

Tips

- Use `fdel` to remove unwanted data (for example, outlier points) at specified frequencies.
- Use `fdel` to remove data at intersecting frequencies from `frd` models before merging them with `fcats`. `fcats` produces an error when you attempt to merge `frd` models that have intersecting frequency data.
- To remove data from an `frd` model within a range of frequencies, use `fselect`.

Version History

Introduced in R2010a

See Also

`fcats` | `fselect` | `frd`

feedback

Feedback connection of multiple models

Syntax

```
sys = feedback(sys1,sys2)
sys = feedback(sys1,sys2,feedin,feedout)
sys = feedback(sys1,sys2,'name')
```

```
sys = feedback( ____,sign)
```

Description

`sys = feedback(sys1,sys2)` returns a model object `sys` for the negative feedback interconnection of model objects `sys1,sys2`.

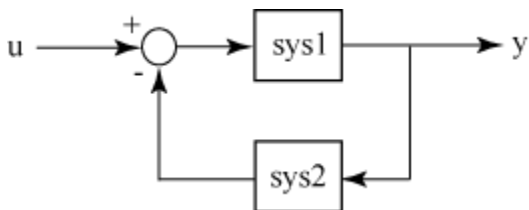

From the figure, the closed-loop model `sys` has `u` as input vector and `y` as output vector. Both models, `sys1` and `sys2`, must either be continuous or discrete with identical sample times.

`sys = feedback(sys1,sys2,feedin,feedout)` computes a closed-loop model `sys` using the input and output connections specified using `feedin` and `feedout`. Use this syntax when you want to connect only a subset of the available I/Os of MIMO systems.

`sys = feedback(sys1,sys2,'name')` computes a closed-loop model `sys` with the feedback connections specified by the respective I/O names of MIMO models `sys1` and `sys2`. Use the `'name'` flag only when all the required I/Os in the set of MIMO systems are properly named.

`sys = feedback(____,sign)` returns a model object `sys` for a feedback loop with the type of feedback specified by `sign`. By default, `feedback` assumes negative feedback and is equivalent to `feedback(sys1,sys2,-1)`. To compute the closed-loop system with positive feedback, use `sign = +1`.

Examples

Plant and Controller with Unit Feedback

`pendulumModelAndController.mat` contains a SISO inverted pendulum transfer function model `G` and its associated PID controller `C`.

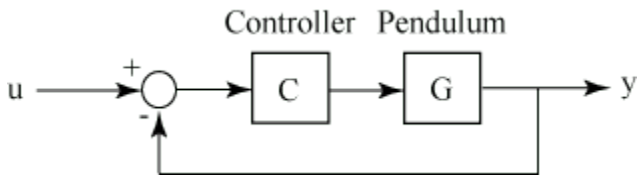

Load the inverted pendulum and controller model to the workspace.

```
load('pendulumModelAndController','G','C');
size(G)
```

Transfer function with 1 outputs and 1 inputs.

```
size(C)
```

PID controller with 1 output and 1 input.

Use `feedback` to create the negative feedback loop with G and C.

```
sys = feedback(G*C,1)
```

```
sys =
```

```

      1.307e-06 s^3 + 3.136e-05 s^2 + 5.227e-06 s
-----
 2.3e-06 s^4 + 1.725e-06 s^3 - 4.035e-05 s^2 - 5.018e-06 s
```

Continuous-time transfer function.

`sys` is the resultant closed loop continuous-time transfer function obtained using negative feedback. `feedback` converts the PID controller model `C` to a transfer function before connecting it to the continuous-time transfer function model `G`. For more information, see “Rules That Determine Model Type”.

Plant with Controller in Negative Feedback Path

For this example, consider two transfer functions that describe a plant `G` and controller `C` respectively.

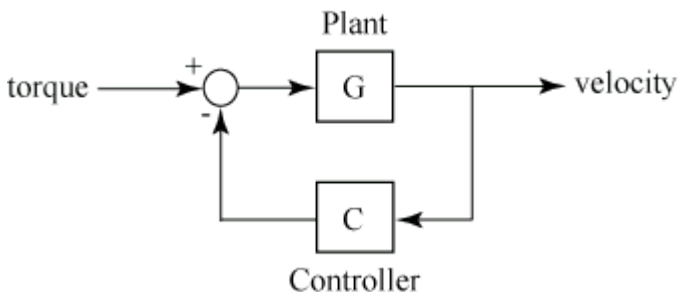

$$G(s) = \frac{2s^2 + 5s + 1}{s^2 + 2s + 3} \quad C(s) = \frac{5(s + 2)}{s + 10}$$

Create the plant and controller transfer functions.

```
G = tf([2 5 1],[1 2 3], 'inputname', "torque", 'outputname', "velocity");
C = tf([5,10],[1,10]);
```

Use feedback to create the negative feedback loop using G and C.

```
sys = feedback(G,C,-1)
```

```
sys =
```

```
From input "torque" to output "velocity":
 2 s^3 + 25 s^2 + 51 s + 10
-----
11 s^3 + 57 s^2 + 78 s + 40
```

Continuous-time transfer function.

`sys` is the resultant closed loop transfer function obtained using negative feedback with *torque* as the input and *velocity* as the output.

Positive Feedback Loop with Plant and Controller

For this example, consider two transfer functions that describe a plant G and controller C respectively.

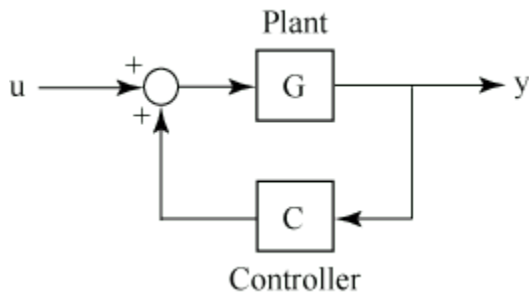

$$G(s) = \frac{2s^2 + 5s + 1}{s^2 + 2s + 3} \quad C(s) = \frac{5(s + 2)}{s + 10}$$

Create the plant and controller transfer functions.

```
G = tf([2 5 1],[1 2 3], 'inputname', "torque", 'outputname', "velocity");
C = tf([5,10],[1,10]);
```

Use feedback to create the positive feedback loop using G and C.

```
sys = feedback(G,C,+1)
```

```
sys =
```

```
From input "torque" to output "velocity":
-2 s^3 - 25 s^2 - 51 s - 10
-----
 9 s^3 + 33 s^2 + 32 s - 20
```

Continuous-time transfer function.

`sys` is the resultant closed loop transfer function obtained using positive feedback with *torque* as the input and *velocity* as the output.

Negative Feedback Loop with MIMO Systems

Based on the figure below, consider connecting two MIMO transfer functions with two inputs and two outputs in a negative feedback loop.

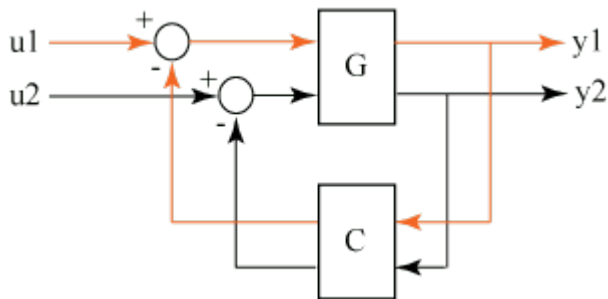

For this example, create two random continuous state-space models using `rss`.

```
G = rss(4,2,2);
C = rss(2,2,2);
size(G)
```

State-space model with 2 outputs, 2 inputs, and 4 states.

```
size(C)
```

State-space model with 2 outputs, 2 inputs, and 2 states.

Use `feedback` to connect the two state-space models in a negative feedback loop according to the above figure.

```
sys = feedback(G,C,-1);
size(sys)
```

State-space model with 2 outputs, 2 inputs, and 6 states.

The resulting state-space model `sys` is a 2 input, 2 output model with 6 states. The negative feedback loop is completed such that,

- The first output of `G` is connected to the first input of `C`
- The second output of `G` is connected to the second input of `C`

Feedback Loop Based on I/O Names

`mimoPlantAndController.mat` contains a 2 input, 2 output transfer function plant model `G` and a 2 input, 2 output transfer function controller model `C` to be connected as follows:

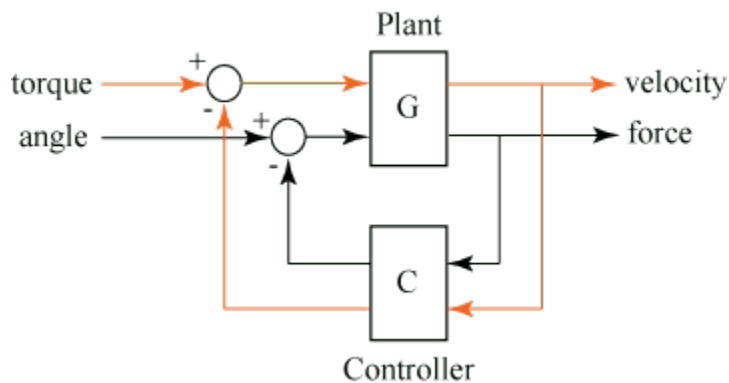

First, load the plant and controller models to the workspace.

```
load('mimoPlantAndController.mat', 'G', 'C');
size(G)
```

Transfer function with 2 outputs and 2 inputs.

```
size(C)
```

Transfer function with 2 outputs and 2 inputs.

By default, feedback would connect the first output of G to the first input of C and the second output of G to the second input of C. In order to connect the plant and controller according to the figure, name the respective I/Os of the two systems to ensure the correct connections.

G.InputName

```
ans = 2x1 cell
    {'torque'}
    {'angle' }
```

G.OutputName

```
ans = 2x1 cell
    {'velocity'}
    {'force' }
```

C.InputName

```
ans = 2x1 cell
    {'force' }
    {'velocity'}
```

C.OutputName

```
ans = 2x1 cell
    {'angle' }
    {'torque'}
```

Then use the 'name' flag with the feedback command to make the connections according to the I/O names.

```
sys = feedback(G,C, 'name');
```

The resulting closed loop negative feedback transfer function `sys` has the feedback connections in the required order.

Specify Input and Output Connections in a Feedback Loop

Consider a state-space plant `G` with five inputs and four outputs and a state-space feedback controller `K` with three inputs and two outputs. The outputs 1, 3, and 4 of the plant `G` must be connected the controller `K` inputs, and the controller outputs to inputs 2 and 4 of the plant.

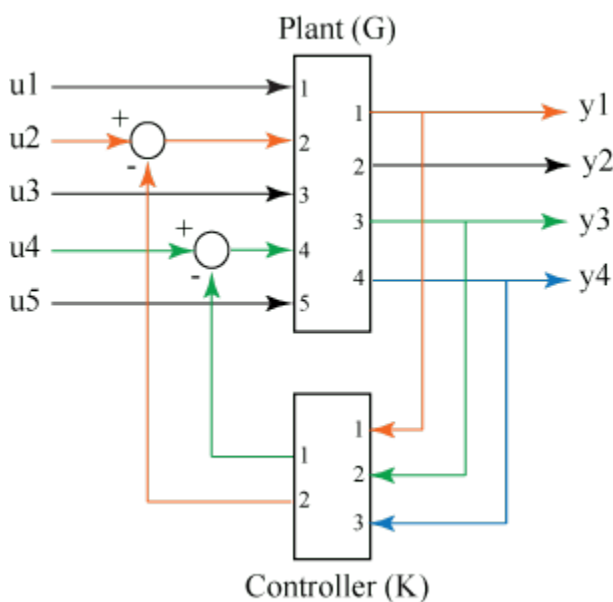

For this example, generate randomized continuous-time state-space models using `rss` for both `G` and `K`.

```
G = rss(3,4,5);
K = rss(3,2,3);
```

Define the `feedin` and `feedout` vectors based on the inputs and outputs to be connected in a feedback loop.

```
feedin = [2 4];
feedout = [1 3 4];
sys = feedback(G,K,feedin,feedout,-1);
size(sys)
```

State-space model with 4 outputs, 5 inputs, and 6 states.

`sys` is the resultant closed loop state-space model obtained by connecting the specified inputs and outputs of `G` and `K`.

Input Arguments

sys1, sys2 — Systems to connect in a feedback loop

dynamic system models

Systems to connect in a feedback loop, specified as dynamic system models. Dynamic systems that you can use include:

- Continuous-time or discrete-time numeric LTI models such as `tf`, `zpk`, `pid`, `pidstd`, or `ss` models.
- Frequency response models such as `frd` or `genfrd`.
- Generalized or uncertain LTI models such as `genss` or `uss` models. (Using uncertain models requires Robust Control Toolbox software.)

The resulting feedback loop assumes

- current values of the tunable components for tunable control design blocks.
- nominal model values for uncertain control design blocks.

For more information, see dynamic system models.

When `sys1` and `sys2` are two different model types, `feedback` uses precedence rules to determine the resulting model `sys`. For example, when a state-space model and a transfer function is connected in a feedback loop, the resulting system is a state-space model based on the precedence rules. For more information, see “Rules That Determine Model Type”.

feedin — Subset of inputs to be used

vector

Subset of inputs to be used, specified as a vector.

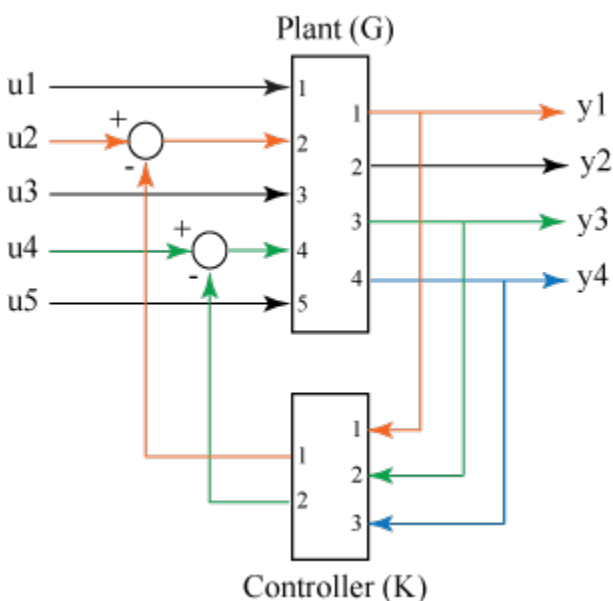

From the figure, `feedin` contains indices of the input vector of MIMO plant `P` and specifies which subset of inputs `u` are involved in the feedback loop. The resulting model `sys` has the same inputs as `G`, with their orders preserved.

For an example, see “Specify Input and Output Connections in a Feedback Loop” on page 2-284.

feedout — Subset of outputs to be used

vector

Subset of outputs to be used, specified as a vector.

`feedout` specifies which outputs of MIMO plant `G` are used for feedback. The resulting model `sys` has the same outputs as `G`, with their orders preserved.

For an example, see “Specify Input and Output Connections in a Feedback Loop” on page 2-284.

sign — Type of feedback

-1 (default) | +1

Type of feedback, specified as -1 for negative feedback or +1 for positive feedback. `feedback` assumes negative feedback by default.

Output Arguments

sys — Closed-loop system

dynamic system model

Closed-loop system, returned as a SISO, or MIMO dynamic system model. `sys` can be one of the following depending on the precedence rules:

- Continuous-time or discrete-time numeric LTI models, such as `tf`, `zpk`, `ss`, `pid`, or `pidstd` models.
- Generalized or uncertain LTI models such as `genss` or `uss` models. (Using uncertain models requires Robust Control Toolbox software.)

When `sys1` and `sys2` are two different model types, `feedback` uses precedence rules to determine the resulting model `sys`. For example, when a state-space model and a transfer function is connected in a feedback loop, the resulting system is a state-space model based on the precedence rules outlined in “Rules That Determine Model Type”.

Limitations

- The feedback connection must be free of algebraic loops. For instance, if D_1 and D_2 are the feedthrough matrices of `sys1` and `sys2`, this condition is equivalent to:
 - $I + D_1D_2$ nonsingular when using negative feedback
 - $I - D_1D_2$ nonsingular when using positive feedback

Tips

- For complicated feedback structures, use `append` and `connect`.

Version History

Introduced before R2006a

See Also

append | connect | series | lft | sumblk | parallel

Topics

“Rules That Determine Model Type”

“MIMO Feedback Loop”

“Using FEEDBACK to Close Feedback Loops”

filt

Specify discrete transfer functions in DSP format

Syntax

```
sys = filt(numerator,denominator)
sys = filt(numerator,denominator,ts)
sys = filt(m)
sys = filt( ___,Name,Value)
```

Description

Use `filt` to create discrete-time transfer function models in digital signal processing (DSP) form for use with Control System Toolbox linear analysis and control design tools. To apply a filter to vector data, see `filter`.

In DSP, it is conventional to use transfer functions as rational expressions in z^{-1} and to order the numerator and denominator terms in *ascending* powers of z^{-1} . For example:

$$H(z^{-1}) = \frac{2 + z^{-1}}{1 + 0.4z^{-1} + 2z^{-2}}$$

`filt` creates a `tf` object with the `Variable` property set to ' z^{-1} '. For more information, see `tf`.

`sys = filt(numerator,denominator)` creates a discrete-time transfer function model in DSP form using the coefficients specified in the `numerator` and `denominator` arguments. The sample time is left unspecified. For more information, see the `tf` reference page.

`sys = filt(numerator,denominator,ts)` sets the sample time of the discrete-time transfer function.

`sys = filt(m)` creates a discrete-time transfer function model that represents the static gain matrix, `m`.

`sys = filt(___,Name,Value)` sets properties of the discrete-time transfer function model using one or more `Name,Value` pair arguments for any of the previous input-argument combinations. For information about the available properties and their values, see the `tf` reference page.

Examples

Discrete-Time Transfer Function Model in DSP Form

For this example, create a discrete-time transfer function model in DSP form using the `filt` command.

First, specify the numerator and denominator coefficients in ascending orders of z^{-1} .

```
numerator = [2,5,7];
denominator = [6,8,3];
```

Use `filt` to create the required DSP-oriented transfer function model.

```
sys = filt(numerator,denominator)
```

```
sys =
```

$$\frac{2 + 5 z^{-1} + 7 z^{-2}}{6 + 8 z^{-1} + 3 z^{-2}}$$

```
Sample time: unspecified
Discrete-time transfer function.
```

`sys` is a discrete-time transfer function model in DSP form with the sample time unspecified, that is, the coefficients are ordered in increasing powers of z^{-1} .

Alternatively, you can create the same model using the `tf` command by setting the `Variable` property to z^{-1} .

```
systf = tf(numerator,denominator,-1,'Variable','z^-1')
```

```
systf =
```

$$\frac{2 + 5 z^{-1} + 7 z^{-2}}{6 + 8 z^{-1} + 3 z^{-2}}$$

```
Sample time: unspecified
Discrete-time transfer function.
```

DSP-Oriented Discrete-Time Transfer Function Model

For this example, create a DSP-oriented discrete-time transfer function model with a sample time 0.2 seconds.

First, specify the numerator and denominator coefficients in ascending powers of z^{-1} .

```
numerator = [2,9];
denominator = [3,5,7,1];
ts = 0.2;
```

Next, create the required transfer function model using `filt`.

```
sys = filt(numerator,denominator,ts)
```

```
sys =
```

$$\frac{2 + 9 z^{-1}}{3 + 5 z^{-1} + 7 z^{-2} + z^{-3}}$$

```
Sample time: 0.2 seconds
Discrete-time transfer function.
```

`sys` is a discrete-time transfer function model in DSP form with a sample time of 0.2 seconds. The coefficients are ordered in ascending orders of z^{-1} for a DSP-oriented transfer function model.

Discrete-Time Transfer Function in DSP Format with Named Inputs

For this example, create a two-input discrete-time transfer function model in DSP format and name the inputs `channel1` and `channel2`, respectively.

```
numerator = {1,[1 0.3]};
denominator = {[1 1 2],[5 2]};
sys = filt(numerator,denominator,'InputName',{'channel1' 'channel2'})
```

```
sys =
```

```
From input "channel1" to output:
```

```
      1
-----
1 + z^-1 + 2 z^-2
```

```
From input "channel2" to output:
```

```
1 + 0.3 z^-1
-----
5 + 2 z^-1
```

```
Sample time: unspecified
Discrete-time transfer function.
```

Alternatively, you can also use the `tf` command to create the same discrete-time transfer function model by setting the `Variable` property to `z^-1`.

```
systf = tf(numerator,denominator,-1,'InputName',{'channel1' 'channel2'},'Variable','z^-1')
```

```
systf =
```

```
From input "channel1" to output:
```

```
      1
-----
1 + z^-1 + 2 z^-2
```

```
From input "channel2" to output:
```

```
1 + 0.3 z^-1
-----
5 + 2 z^-1
```

```
Sample time: unspecified
Discrete-time transfer function.
```

Input Arguments

numerator — Numerator coefficients

row vector | N_y -by- N_u cell array of row vectors

Numerator coefficients, specified as:

- A row vector of polynomial coefficients in order of ascending powers of `'z^-1'`.
- An N_y -by- N_u cell array of row vectors to specify a MIMO transfer function, where N_y is the number of outputs and N_u is the number of inputs. Each element of the cell array specifies the

numerator coefficients for a given input/output pair. If you specify both `Numerator` and `Denominator` as cell arrays, they must have the same dimensions.

The coefficients of `Numerator` can be either real-valued or complex-valued.

denominator — Denominator coefficients

row vector | Ny-by-Nu cell array of row vectors

Denominator coefficients, specified as:

- A row vector of polynomial coefficients in order of ascending powers of ' z^{-1} '.
- An Ny-by-Nu cell array of row vectors to specify a MIMO transfer function, where Ny is the number of outputs and Nu is the number of inputs. Each element of the cell array specifies the numerator coefficients for a given input/ output pair. If you specify both `Numerator` and `Denominator` as cell arrays, they must have the same dimensions.

If all SISO entries of a MIMO transfer function have the same denominator, you can specify `Denominator` as the row vector while specifying `Numerator` as a cell array.

The coefficients of `Denominator` can be either real-valued or complex-valued.

ts — Sample time

positive scalar | -1

Sample time, specified as:

- A positive scalar representing the sampling period of a discrete-time system. Specify `ts` in the time unit specified by the `TimeUnit` property of the transfer function object.
- -1 for a discrete-time system with an unspecified sample time.

m — Static gain

scalar | matrix

Static gain, specified as a scalar or matrix. Static gain or steady state gain of a system represents the ratio of the output to the input under steady state condition.

Output Arguments

sys — Discrete-time transfer function in DSP format

tf model object

Discrete-time transfer function in DSP format, returned as a transfer function (tf) model object with the `Variable` property set to ' z^{-1} '. For more information, see the `tf` reference page.

Version History

Introduced before R2006a

See Also

tf

fnorm

Pointwise peak gain of FRD model

Syntax

```
fnm = fnorm(sys)  
fnm = fnorm(sys, ntype)
```

Description

`fnm = fnorm(sys)` computes the pointwise 2-norm of the frequency response contained in the FRD model `sys`, that is, the peak gain at each frequency point. The output `fnm` is an FRD object containing the peak gain across frequencies.

`fnm = fnorm(sys, ntype)` computes the frequency response gains using the matrix norm specified by `ntype`. See `norm` for valid matrix norms and corresponding `NTYPE` values.

Version History

Introduced in R2006a

See Also

`norm` | `abs`

fourierBasis

Fourier basis functions for tunable gain surface

Syntax

```
shapefcn = fourierBasis(N)
shapefcn = fourierBasis(N,nvars)
shapefcn = fourierBasis( ____,varnames)
```

Description

You use basis function expansions to parameterize gain surfaces for tuning gain-scheduled controllers. `fourierBasis` generates periodic Fourier series expansions for parameterizing gain surfaces that depend periodically on the scheduling variables, such as a gain that varies with angular position. Use the output of `fourierBasis` to create tunable gain surfaces with `tunableSurface`.

`shapefcn = fourierBasis(N)` generates a function that evaluates the first N harmonics of e^{imx} :

$$F(x) = [\cos(\pi x), \sin(\pi x), \cos(2\pi x), \sin(2\pi x), \dots, \cos(N\pi x), \sin(N\pi x)].$$

F is the function represented by `shapefcn`. The term of F are the first $2*N$ basis functions in the Fourier series expansion of a periodically varying gain, $K(x)$, with $K(-1) = K(1)$. That expansion is given by:

$$K(x) = \frac{a_0}{2} + \sum_k \{a_k \cos(k\pi x) + b_k \sin(k\pi x)\}.$$

`shapefcn = fourierBasis(N,nvars)` generates an $nvars$ -dimensional Fourier basis for periodic functions on the region $[-1,1]^{nvars}$. This basis is the outer product of $nvars$ Fourier bases with N harmonics along each dimension. The resulting function `shapefcn` takes $nvars$ input arguments and returns a vector with $(2*N+1)^{(nvars-1)} - 1$ entries.

To specify basis functions of multiple scheduling variables where the expansions are different for each variable, use `ndBasis`.

`shapefcn = fourierBasis(____,varnames)` specifies variable names. Use this syntax with any of the previous syntaxes to name the variables in `shapefcn`. Using variable names improves readability of the `tunableSurface` object display and of any MATLAB code you generate using codegen.

Examples

Fourier Basis Functions of One Scheduling Variable

Create basis functions for a gain that varies as a periodic function of one scheduling variable.

```
shapefcn = fourierBasis(2);
```

`shapefcn` is a handle to a function of one variable that returns an array of four values corresponding to the first two harmonics of a periodic function on $x = [-1,1]$:

$$F(x) = [\cos(\pi x), \sin(\pi x), \cos(2\pi x), \sin(2\pi x)].$$

Use `shapefcn` as an input argument to `tunableSurface` to define a gain surface of the form:

$$K(x) = K_0 + K_1\cos(\pi x) + K_2\sin(\pi x) + K_3\cos(2\pi x) + K_4\sin(2\pi x).$$

The variable x is a normalized version of the scheduling variable for your tunable surface. Because the basis functions created by `fourierBasis` act on normalized variables, your gain-scheduled system must use design points whose endpoint values delineate exactly one period. For example, suppose you use the following design points:

```
alpha = [-7, -4, -1, 2, 5];
domain = struct('alpha', alpha);
K = tunableSurface('K', 0, domain, shapefcn);
```

In normalizing the domain, the software assumes that the gain surface, K , is periodic in `alpha` such that $K(-7) = K(5)$.

Fourier Basis Functions in Higher Dimensions

Create a two-dimensional Fourier basis for periodic functions of x and y on the domain $[-1, 1]^N$. The basis functions should go up to the third harmonic in both the x and y dimensions.

```
F2D = fourierBasis(3,2);
```

This function is the outer product of two vectors:

```
x = fourierBasis(3);
y = fourierBasis(3);
```

Equivalently, you can obtain the outer product using `ndBasis`.

```
F = fourierBasis(3);
F2D = ndBasis(F,F);
```

The values in the vector returned by `F` include cross-terms such as $\sin(\pi x)\cos(\pi y)$ and $\sin(3\pi x)\cos(2\pi y)$.

Input Arguments

N — Number of harmonics of Fourier expansion

positive integer

Number of harmonics of Fourier expansion, specified as a positive integer.

nvars — Number of variables

1 (default) | positive integer

Number of scheduling variables, specified as a positive integer.

varnames — Variable names

{'x1', 'x2', ...} (default) | character vector | cell array of character vectors

Variable names in the generated function `shapefcn`, specified as a:

- Character vector, for monovariate basis functions.
- Cell array of character vectors, for multivariate basis functions.

If you do not specify `varnames`, then the variables in `shapefcn` are named {'x1', 'x2', ...}.

Example: {'alpha', 'V'}

Output Arguments**shapefcn — Fourier expansion**

function handle

Fourier expansion, specified as a function handle. `shapefcn` takes as input arguments the number of variables specified by `nvars`. It returns a vector of polynomials in those variables, defined on the interval $[-1,1]$ for each input variable. When you use `shapefcn` to create a gain surface, `tunableSurface` automatically generates tunable coefficients for each polynomial term in the vector.

Tips

- If the gain surface K is periodic in the scheduling variable x with period P , make sure that the corresponding entry in `K.Normalization.InputScaling` is set to $P/2$ to ensure consistency with the `fourierBasis` period, $P = 2$. When using the default normalization, the x values in `K.SamplingGrid` must span exactly one period, $[a, a+P]$, to satisfy this requirement. See the `Normalization` property of `tunableSurface` for more details.

Version History

Introduced in R2015b

See Also

`tunableSurface` | `ndBasis` | `polyBasis`

frd

Frequency-response data model

Description

Use `frd` to create real-valued or complex-valued frequency-response data models, or to convert dynamic system models to frequency-response data model form.

Frequency-response data models store complex frequency response data with corresponding frequency points. For example, a frequency-response data model $H(j\omega_i)$, stores the frequency response at each input frequency ω_i , where $i = 1, \dots, n$. The `frd` model object can represent SISO or MIMO frequency-response data models in continuous time or discrete time. For more information, see “Frequency Response Data (FRD) Models”.

You can also use `frd` to create generalized frequency-response data (`genfrd`) models.

Creation

You can obtain `frd` models in one of the following ways.

- Create the model from frequency response data using the `frd` command. For example, you can create an `frd` model with frequency response data taken at specific frequencies.

For an example, see “SISO Frequency-Response Data Model” on page 2-304.

- Convert a linear model such as an `ss` model into an `frd` model by computing the frequency response of the model at specified frequencies.

For an example, see “Convert State-Space Model to Frequency-Response Data Model” on page 2-309.

- Estimate the model using offline frequency response estimation workflows. These workflows require Simulink Control Design software.

For more information, see “Estimate Frequency Response at the Command Line” (Simulink Control Design) and “Estimate Frequency Response Using Model Linearizer” (Simulink Control Design).

Syntax

```
sys = frd(response, frequency)
sys = frd(response, frequency, ts)
sys = frd(response, frequency, ltiSys)

sys = frd( ___, Name, Value)

sys = frd(ltiSys, frequency)
sys = frd(ltiSys, frequency, FrequencyUnits)
```

Description

`sys = frd(response, frequency)` creates a continuous-time frequency-response data (frd) model, setting the `ResponseData` and `Frequency` properties. `frequency` can contain both negative and positive frequencies.

`sys = frd(response, frequency, ts)` creates a discrete-time frd model with the sample time `ts`. To leave the sample time unspecified, set `ts` to `-1`.

`sys = frd(response, frequency, ltiSys)` creates a frequency-response data model with properties inherited from the dynamic system model `ltiSys`, including the sample time.

`sys = frd(___, Name, Value)` sets properties of the frequency-response data model using one or more name-value arguments for any of the previous input-argument combinations.

`sys = frd(ltiSys, frequency)` converts the dynamic system model `ltiSys` to a frequency-response data model. `frd` computes the frequency response at frequencies specified by `frequency`. `sys` inherits its frequency units `rad/TimeUnit` from `ltiSys.TimeUnit`.

`sys = frd(ltiSys, frequency, FrequencyUnits)` interprets frequencies in the units specified by `FrequencyUnit`.

Input Arguments

response — Frequency response data

vector | multidimensional array

Frequency response data, specified as a vector or a multidimensional array of complex numbers.

- For SISO systems, specify a vector of frequency response values at the frequency points specified in `frequency`.
- For MIMO systems with `Nu` inputs and `Ny` outputs, specify a `Ny`-by-`Nu`-by-`Nf` array, where `Nf` is the number of frequency points.
- For an `S1-...-by-Sn` array of models with `Nu` inputs and `Ny` outputs, specify a multidimensional array of size `[Ny Nu Nf S1 ... Sn]`.

For instance, a `response` of size `[Ny,Nu,Nf,3,4]` represents the response data for a 3-by-4 array of models. Each model has `Ny` outputs, `Nu` inputs, and `Nf` frequency points.

This input sets the `ResponseData` property.

frequency — Frequency points

vector

Frequency points corresponding to `response`, specified as a vector that contains `Nf` points. `frequency` can contain both positive and negative frequencies.

This input sets the `Frequency` property.

ts — Sample time

scalar

Sample time, specified as a scalar.

The input sets the `Ts` property.

LtiSys — Dynamic system

dynamic system model | model array

Dynamic system, specified as a SISO or MIMO dynamic system model or an array of dynamic system models. Dynamic systems that you can use include:

- Continuous-time or discrete-time numeric LTI models, such as `tf`, `zpk`, `ss`, or `pid` models.
- Generalized or uncertain LTI models such as `genss` or `uss` models. (Using uncertain models requires Robust Control Toolbox software.)

The resulting `frd` model assumes:

- Current values of the tunable components for tunable control design blocks
- Nominal model values for uncertain control design blocks
- Identified LTI models, such as `idtf`, `idss`, `idproc`, `idpoly`, and `idgrey` models. (Using identified models requires System Identification Toolbox software.)

Properties**ResponseData — Frequency response data**

multidimensional array of complex numbers

Frequency response data, specified as a multidimensional array of complex numbers.

- For SISO systems, `ResponseData` is a 1-by-1-by-`Nf` array of frequency response values at the `Nf` frequency points specified in the `Frequency` property.
- For MIMO systems with `Nu` inputs and `Ny` outputs, `ResponseData` is an `Ny`-by-`Nu`-by-`Nf` array, where `Nf` is the number of frequency points.

For instance, `ResponseData(ky, ku, kf)` represents the frequency response from the input `ku` to the output `ky` at the frequency `Frequency(kf)`.

- For an `S1-...-by-Sn` array of models with `Nu` inputs and `Ny` outputs, `ResponseData` is a multidimensional array of size `[Ny Nu Nf S1 ... Sn]`.

For instance, a `ResponseData` of size `[Ny,Nu,Nf,3,4]` represents the response data for a 3-by-4 array of models. Each model has `Ny` outputs, `Nu` inputs, and `Nf` frequency points.

Frequency — Frequency points

vector

Frequency points corresponding to `ResponseData`, specified as a vector that contains `Nf` points in the units specified by `FrequencyUnit`.

FrequencyUnit — Units for frequency vector

'rad/TimeUnit' (default) | 'cycles/TimeUnit' | 'rad/s' | 'Hz' | 'kHz' | 'MHz' | 'GHz' | 'rpm'

Units of the frequency vector in the `Frequency` property, specified as one of the following values:

- 'rad/TimeUnit'
- 'cycles/TimeUnit'

- 'rad/s'
- 'Hz'
- 'kHz'
- 'MHz'
- 'GHz'
- 'rpm'

The units 'rad/TimeUnit' and 'cycles/TimeUnit' are relative to the time units specified in the TimeUnit property.

Changing this property does not resample or convert the data. Modifying the property changes only the interpretation of the existing data. Use `chgFreqUnit` to convert the data to different frequency units.

IODelay — Transport delay

0 (default) | scalar | Ny-by-Nu array

Transport delay, specified as one of the following:

- Scalar — Specify the transport delay for a SISO system or the same transport delay for all input/output pairs of a MIMO system.
- Ny-by-Nu array — Specify separate transport delays for each input/output pair of a MIMO system. Here, Ny is the number of outputs and Nu is the number of inputs.

For continuous-time systems, specify transport delays in the time unit specified by the TimeUnit property. For discrete-time systems, specify transport delays in integer multiples of the sample time, Ts.

InputDelay — Input delay

0 (default) | scalar | Nu-by-1 vector

Input delay for each input channel, specified as one of the following:

- Scalar — Specify the input delay for a SISO system or the same delay for all inputs of a multi-input system.
- Nu-by-1 vector — Specify separate input delays for input of a multi-input system, where Nu is the number of inputs.

For continuous-time systems, specify input delays in the time unit specified by the TimeUnit property. For discrete-time systems, specify input delays in integer multiples of the sample time, Ts.

For more information, see “Time Delays in Linear Systems”.

OutputDelay — Output delay

0 (default) | scalar | Ny-by-1 vector

Output delay for each output channel, specified as one of the following:

- Scalar — Specify the output delay for a SISO system or the same delay for all outputs of a multi-output system.
- Ny-by-1 vector — Specify separate output delays for output of a multi-output system, where Ny is the number of outputs.

For continuous-time systems, specify output delays in the time unit specified by the `TimeUnit` property. For discrete-time systems, specify output delays in integer multiples of the sample time, `Ts`.

For more information, see “Time Delays in Linear Systems”.

Ts — Sample time

0 (default) | positive scalar | -1

Sample time, specified as:

- 0 for continuous-time systems.
- A positive scalar representing the sampling period of a discrete-time system. Specify `Ts` in the time unit specified by the `TimeUnit` property.
- -1 for a discrete-time system with an unspecified sample time.

Note Changing `Ts` does not discretize or resample the model.

TimeUnit — Time variable units

'seconds' (default) | 'nanoseconds' | 'microseconds' | 'milliseconds' | 'minutes' | 'hours' | 'days' | 'weeks' | 'months' | 'years' | ...

Time variable units, specified as one of the following:

- 'nanoseconds'
- 'microseconds'
- 'milliseconds'
- 'seconds'
- 'minutes'
- 'hours'
- 'days'
- 'weeks'
- 'months'
- 'years'

Changing `TimeUnit` has no effect on other properties, but changes the overall system behavior. Use `chgTimeUnit` to convert between time units without modifying system behavior.

InputName — Input channel names

' ' (default) | character vector | cell array of character vectors

Input channel names, specified as one of the following:

- A character vector, for single-input models.
- A cell array of character vectors, for multi-input models.
- ' ', no names specified, for any input channels.

Alternatively, you can assign input names for multi-input models using automatic vector expansion. For example, if `sys` is a two-input model, enter the following:

```
sys.InputName = 'controls';
```

The input names automatically expand to {'controls(1)'; 'controls(2)'}

You can use the shorthand notation `u` to refer to the `InputName` property. For example, `sys.u` is equivalent to `sys.InputName`.

Use `InputName` to:

- Identify channels on model display and plots.
- Extract subsystems of MIMO systems.
- Specify connection points when interconnecting models.

InputUnit — Input channel units

' ' (default) | character vector | cell array of character vectors

Input channel units, specified as one of the following:

- A character vector, for single-input models.
- A cell array of character vectors, for multi-input models.
- ' ', no units specified, for any input channels.

Use `InputUnit` to specify input signal units. `InputUnit` has no effect on system behavior.

InputGroup — Input channel groups

structure

Input channel groups, specified as a structure. Use `InputGroup` to assign the input channels of MIMO systems into groups and refer to each group by name. The field names of `InputGroup` are the group names and the field values are the input channels of each group. For example, enter the following to create input groups named `controls` and `noise` that include input channels 1 and 2, and 3 and 5, respectively.

```
sys.InputGroup.controls = [1 2];
sys.InputGroup.noise = [3 5];
```

You can then extract the subsystem from the `controls` inputs to all outputs using the following.

```
sys(:, 'controls')
```

By default, `InputGroup` is a structure with no fields.

OutputName — Output channel names

' ' (default) | character vector | cell array of character vectors

Output channel names, specified as one of the following:

- A character vector, for single-output models.
- A cell array of character vectors, for multi-output models.
- ' ', no names specified, for any output channels.

Alternatively, you can assign output names for multi-output models using automatic vector expansion. For example, if `sys` is a two-output model, enter the following.

```
sys.OutputName = 'measurements';
```

The output names automatically expand to `{'measurements(1)'; 'measurements(2)'}`.

You can also use the shorthand notation `y` to refer to the `OutputName` property. For example, `sys.y` is equivalent to `sys.OutputName`.

Use `OutputName` to:

- Identify channels on model display and plots.
- Extract subsystems of MIMO systems.
- Specify connection points when interconnecting models.

OutputUnit — Output channel units

`''` (default) | character vector | cell array of character vectors

Output channel units, specified as one of the following:

- A character vector, for single-output models.
- A cell array of character vectors, for multi-output models.
- `''`, no units specified, for any output channels.

Use `OutputUnit` to specify output signal units. `OutputUnit` has no effect on system behavior.

OutputGroup — Output channel groups

structure

Output channel groups, specified as a structure. Use `OutputGroup` to assign the output channels of MIMO systems into groups and refer to each group by name. The field names of `OutputGroup` are the group names and the field values are the output channels of each group. For example, create output groups named `temperature` and `measurement` that include output channels 1, and 3 and 5, respectively.

```
sys.OutputGroup.temperature = [1];
sys.OutputGroup.measurement = [3 5];
```

You can then extract the subsystem from all inputs to the `measurement` outputs using the following.

```
sys('measurement', :)
```

By default, `OutputGroup` is a structure with no fields.

Name — System name

`''` (default) | character vector

System name, specified as a character vector. For example, `'system_1'`.

Notes — User-specified text

`{}` (default) | character vector | cell array of character vectors

User-specified text that you want to associate with the system, specified as a character vector or cell array of character vectors. For example, `'System is MIMO'`.

UserData — User-specified data

`[]` (default) | any MATLAB data type

User-specified data that you want to associate with the system, specified as any MATLAB data type.

SamplingGrid — Sampling grid for model arrays

structure array

Sampling grid for model arrays, specified as a structure array.

Use `SamplingGrid` to track the variable values associated with each model in a model array, including identified linear time-invariant (IDLTI) model arrays.

Set the field names of the structure to the names of the sampling variables. Set the field values to the sampled variable values associated with each model in the array. All sampling variables must be numeric scalars, and all arrays of sampled values must match the dimensions of the model array.

For example, you can create an 11-by-1 array of linear models, `sysarr`, by taking snapshots of a linear time-varying system at times `t = 0:10`. The following code stores the time samples with the linear models.

```
sysarr.SamplingGrid = struct('time',0:10)
```

Similarly, you can create a 6-by-9 model array, `M`, by independently sampling two variables, `zeta` and `w`. The following code maps the (`zeta,w`) values to `M`.

```
[zeta,w] = ndgrid(<6 values of zeta>,<9 values of w>)
M.SamplingGrid = struct('zeta',zeta,'w',w)
```

When you display `M`, each entry in the array includes the corresponding `zeta` and `w` values.

`M`

```
M(:,:,1,1) [zeta=0.3, w=5] =
```

```
      25
-----
s^2 + 3 s + 25
```

```
M(:,:,2,1) [zeta=0.35, w=5] =
```

```
      25
-----
s^2 + 3.5 s + 25
```

...

For model arrays generated by linearizing a Simulink model at multiple parameter values or operating points, the software populates `SamplingGrid` automatically with the variable values that correspond to each entry in the array. For instance, the Simulink Control Design commands `linearize` and `sLinearizer` populate `SamplingGrid` automatically.

By default, `SamplingGrid` is a structure with no fields.

Object Functions

The following lists contain a representative subset of the functions you can use with `frd` models. In general, many functions applicable to “Dynamic System Models” are also applicable to a `frd` object. `frd` models do not work with any time-domain analysis functions.

Frequency Response Analysis

bode	Bode plot of frequency response, or magnitude and phase data
sigma	Singular value plot of dynamic system
nyquist	Nyquist plot of frequency response
nichols	Nichols chart of frequency response
bandwidth	Frequency response bandwidth
freqresp	Evaluate system response over a grid of frequencies
margin	Gain margin, phase margin, and crossover frequencies

Model Transformation

chgFreqUnit	Change frequency units of frequency-response data model
chgTimeUnit	Change time units of dynamic system
frdfun	Apply a function to the frequency response value at each frequency of an frd model object
fselect	Select frequency points or range in FRD model
interp	Interpolate FRD model
fcats	Concatenate FRD models along frequency dimension
fnorm	Pointwise peak gain of FRD model

Model Interconnection

feedback	Feedback connection of multiple models
connect	Block diagram interconnections of dynamic systems
series	Series connection of two models
parallel	Parallel connection of two models

Controller Design

pidtune	PID tuning algorithm for linear plant model
---------	---

Examples

SISO Frequency-Response Data Model

Create an frd object from frequency response data.

For this example, load the frequency response data collected for a water tank model.

```
load wtankData.mat
```

This data contains the frequency response data collected for the frequency range 10^{-3} rad/s to 10^2 rad/s.

Create the model.

```
sys = frd(response, frequency)
```

```
sys =
```

Frequency (rad/s)	Response
-----	-----
0.0010	1.562e+01 - 1.9904i
0.0018	1.560e+01 - 2.0947i

0.0034	1.513e+01 - 3.3670i
0.0062	1.373e+01 - 5.4306i
0.0113	1.047e+01 - 7.5227i
0.0207	5.829e+00 - 7.6529i
0.0379	2.340e+00 - 5.6271i
0.0695	7.765e-01 - 3.4188i
0.1274	2.394e-01 - 1.9295i
0.2336	7.216e-02 - 1.0648i
0.4281	2.157e-02 - 0.5834i
0.7848	6.433e-03 - 0.3188i
1.4384	1.916e-03 - 0.1740i
2.6367	5.705e-04 - 0.0950i
4.8329	1.698e-04 - 0.0518i
8.8587	5.055e-05 - 0.0283i
16.2378	1.505e-05 - 0.0154i
29.7635	4.478e-06 - 0.0084i
54.5559	1.333e-06 - 0.0046i
100.0000	3.967e-07 - 0.0025i

Continuous-time frequency response.

Plot sys.

bode(sys)

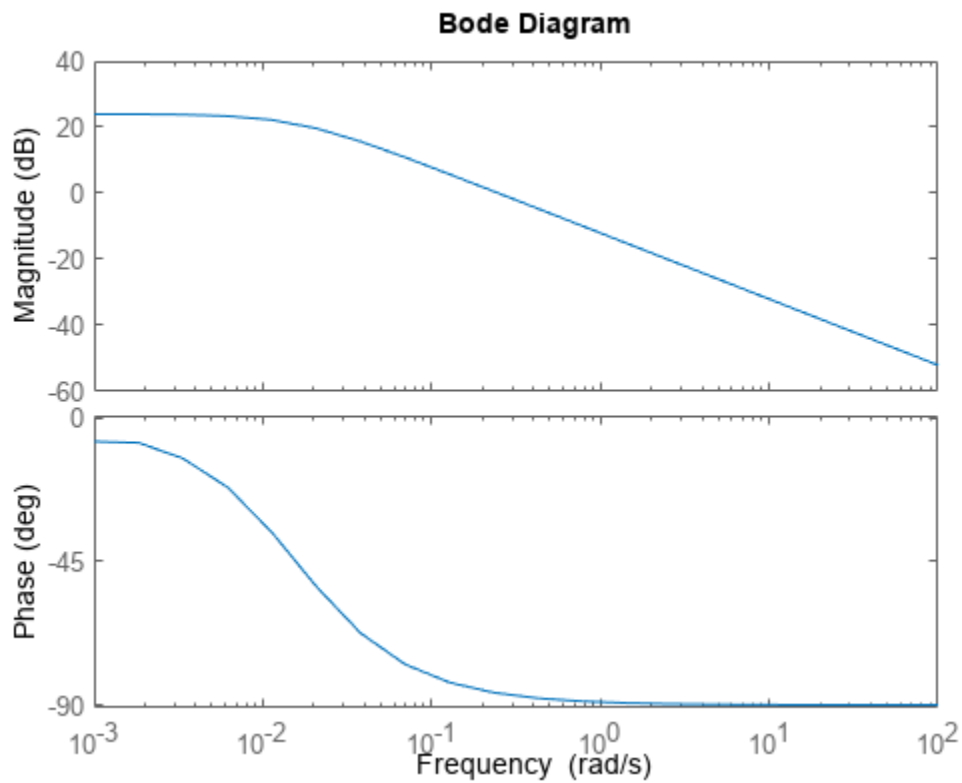

Discrete-Time MIMO Frequency-Response Data Model

For this example, consider randomly generated response data and frequencies.

Generate a 3-by-2-by-7 complex array and a frequency vector with seven points between 0.01 and 100 rad/s. Set the sample time T_s to 5 seconds.

```
rng(0)
r = randn(3,2,7)+1i*randn(3,2,7);
w = logspace(-2,2,7);
Ts = 5;
```

Create the model.

```
sys = frd(r,w,Ts)
```

```
sys =
```

From input 1 to:

Frequency(rad/s)	output 1	output 2
0.0100	0.5377 + 0.3192i	1.8339 + 0.3129i
0.0464	-0.4336 + 1.0933i	0.3426 + 1.1093i
0.2154	0.7254 - 0.0068i	-0.0631 + 1.5326i
1.0000	1.4090 - 1.0891i	1.4172 + 0.0326i
4.6416	0.4889 - 1.4916i	1.0347 - 0.7423i
21.5443	0.8884 - 0.1924i	-1.1471 + 0.8886i
100.0000	0.3252 - 0.1774i	-0.7549 - 0.1961i

From input 1 to:

Frequency(rad/s)	output 3
0.0100	-2.2588 - 0.8649i
0.0464	3.5784 - 0.8637i
0.2154	0.7147 - 0.7697i
1.0000	0.6715 + 0.5525i
4.6416	0.7269 - 1.0616i
21.5443	-1.0689 - 0.7648i
100.0000	1.3703 + 1.4193i

From input 2 to:

Frequency(rad/s)	output 1	output 2
0.0100	0.8622 - 0.0301i	0.3188 - 0.1649i
0.0464	2.7694 + 0.0774i	-1.3499 - 1.2141i
0.2154	-0.2050 + 0.3714i	-0.1241 - 0.2256i
1.0000	-1.2075 + 1.1006i	0.7172 + 1.5442i
4.6416	-0.3034 + 2.3505i	0.2939 - 0.6156i
21.5443	-0.8095 - 1.4023i	-2.9443 - 1.4224i
100.0000	-1.7115 + 0.2916i	-0.1022 + 0.1978i

From input 2 to:

Frequency(rad/s)	output 3
0.0100	-2.2588 - 0.8649i
0.0464	3.5784 - 0.8637i
0.2154	0.7147 - 0.7697i
1.0000	0.6715 + 0.5525i
4.6416	0.7269 - 1.0616i
21.5443	-1.0689 - 0.7648i
100.0000	1.3703 + 1.4193i

```

0.0100      -1.3077 + 0.6277i
0.0464      3.0349 - 1.1135i
0.2154      1.4897 + 1.1174i
1.0000      1.6302 + 0.0859i
4.6416     -0.7873 + 0.7481i
21.5443     1.4384 + 0.4882i
100.0000    -0.2414 + 1.5877i

```

Sample time: 5 seconds
Discrete-time frequency response.

The specified data results in a two-input, three-output frd model.

Frequency-Response Data Model with Inherited Properties

For this example, create a frequency-response data model with properties inherited from a transfer function model.

Create a transfer function `sys1` with the `TimeUnit` property set to 'minutes' and `InputDelay` property set to 3.

```

numerator1 = [2,0];
denominator1 = [1,8,0];
sys1 = tf(numerator1,denominator1,'TimeUnit','minutes','InputDelay',3)

```

`sys1 =`

$$\exp(-3*s) * \frac{2 s}{s^2 + 8 s}$$

Continuous-time transfer function.

```
propValues1 = {sys1.TimeUnit,sys1.InputDelay}
```

```
propValues1=1x2 cell array
    {'minutes'}    {[3]}
```

Create an frd model with properties inherited from `sys1`.

```

rng(0)
response = randn(1,1,7)+1i*randn(1,1,7);
w = logspace(-2,2,7);
sys2 = frd(response,w,sys1)

```

`sys2 =`

Frequency(rad/minute)	Response
0.0100	0.5377 + 0.3426i
0.0464	1.8339 + 3.5784i
0.2154	-2.2588 + 2.7694i
1.0000	0.8622 - 1.3499i
4.6416	0.3188 + 3.0349i
21.5443	-1.3077 + 0.7254i

```
100.0000 -0.4336 - 0.0631i
Input delays (minutes): 3
Continuous-time frequency response.
propValues2 = {sys2.TimeUnit,sys2.InputDelay}
propValues2=1x2 cell array
{'minutes'} {[3]}
```

Observe that the frd model sys2 has that same properties as sys1.

Specify State and Input Names for Frequency-Response Data Model

For this example, load the frequency response data collected for a water tank model.

```
load wtankData.mat
```

The model has one input, Voltage, and one output, Water height.

Create an frd model, specifying the input and output names.

```
sys = frd(response,frequency,'InputName','Voltage','OutputName','Height');
```

Plot the frequency response.

```
bode(sys)
```

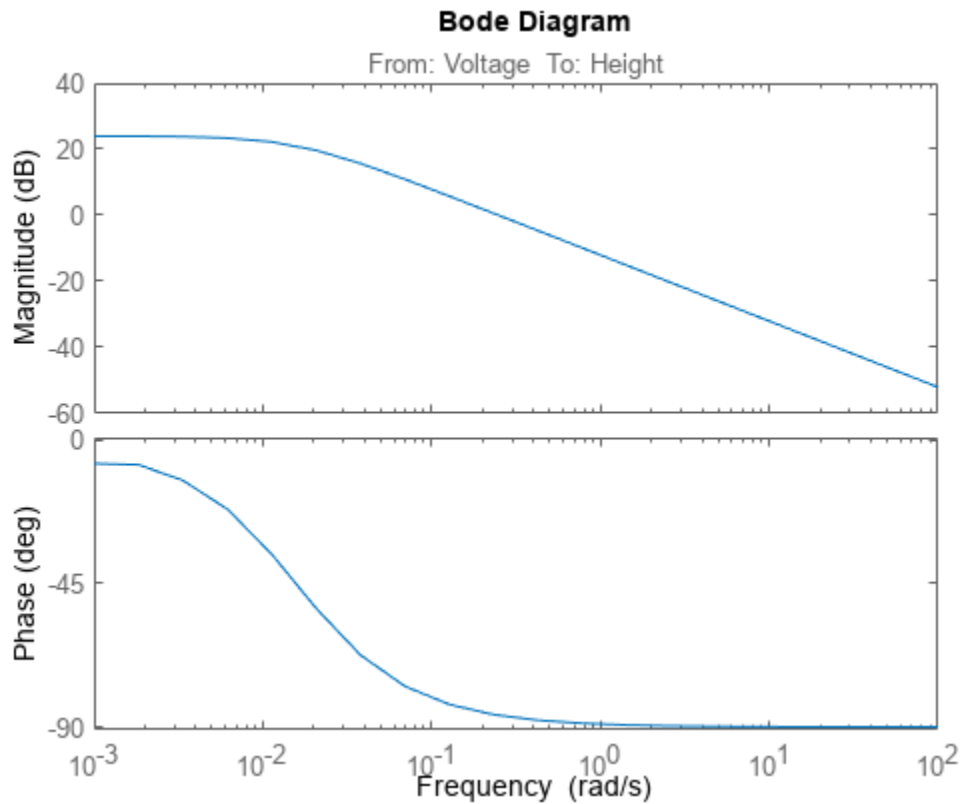

The input and output names appear on the Bode plot. Naming the inputs and outputs can be useful when dealing with response plots for MIMO systems.

Convert State-Space Model to Frequency-Response Data Model

For this example, compute the `frd` model of the following state-space model:

$$A = \begin{bmatrix} -2 & -1 \\ 1 & -2 \end{bmatrix}, B = \begin{bmatrix} 1 & 1 \\ 2 & -1 \end{bmatrix}, C = [1 \ 0], D = [0 \ 1]$$

Create a state-space model using the state-space matrices.

```
A = [-2 -1; 1 -2];
B = [1 1; 2 -1];
C = [1 0];
D = [0 1];
ltiSys = ss(A,B,C,D);
```

Convert the state-space model `ltiSys` to a `frd` model for frequencies between 0.01 and 100 rad/s.

```
w = logspace(-2,2,50);
sys = frd(ltiSys,w);
```

Compare the frequency responses.

```
bode(ltiSys, 'b', sys, 'r--')
```

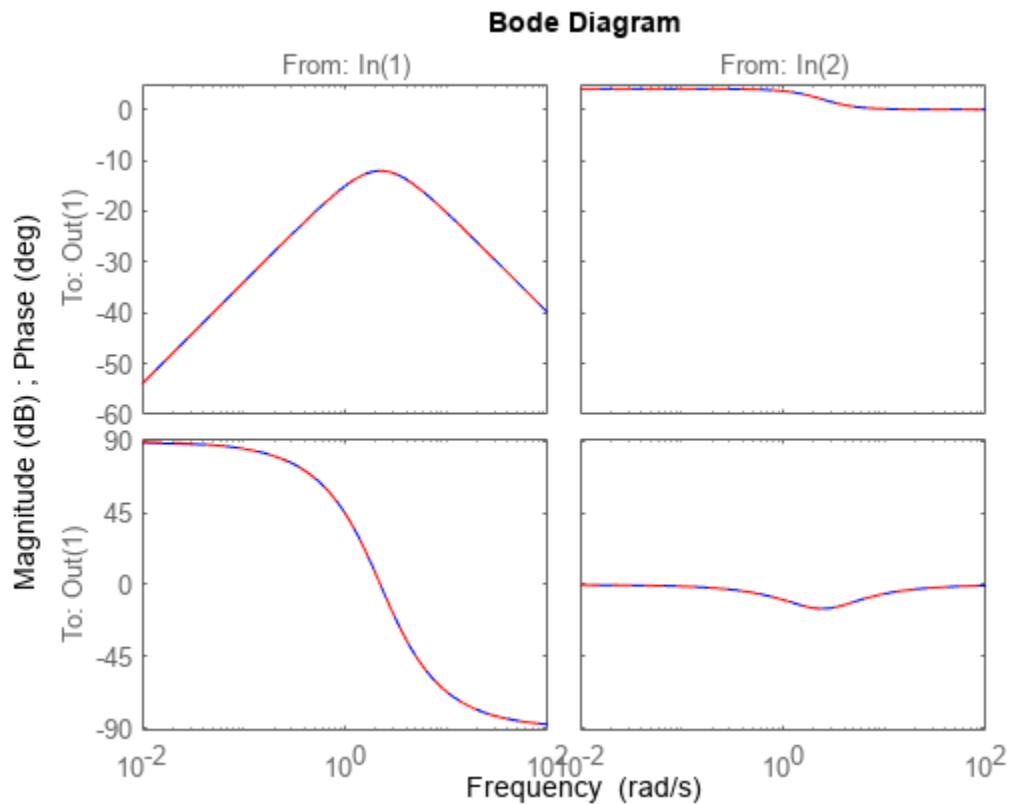

The responses are identical.

Array of Frequency-Response Data Models

To create arrays of `frd` models, you can specify a multidimensional array of frequency response data.

For instance, when you specify the response data as a numeric array of size `[NY NU NF S1 ... Sn]`, the function returns a `S1-by-...-by-Sn` array of `frd` models. Each of these models has `NY` outputs, `NU` inputs, and `NF` frequency points.

Generate a 2-by-3 array of random response data with one-output, two-input models at 10 frequency points between 0.1 and 10 rad/s.

```
w = logspace(-1,1,10);
r = randn(1,2,10,2,3)+1i*randn(1,2,10,2,3);
sys = frd(r,w);
```

Extract the model at the index (2,1) from the model array.

```
sys21 = sys(:,:,2,1)
sys21 =
```

From input 1 to:

Frequency(rad/s)	output 1
-----	-----
0.1000	0.6715 + 0.0229i
0.1668	0.7172 - 1.7502i
0.2783	0.4889 - 0.8314i
0.4642	0.7269 - 1.1564i
0.7743	0.2939 - 2.0026i
1.2915	0.8884 + 0.5201i
2.1544	-1.0689 - 0.0348i
3.5938	-2.9443 + 1.0187i
5.9948	0.3252 - 0.7145i
10.0000	1.3703 - 0.2248i

From input 2 to:

Frequency(rad/s)	output 1
-----	-----
0.1000	-1.2075 - 0.2620i
0.1668	1.6302 - 0.2857i
0.2783	1.0347 - 0.9792i
0.4642	-0.3034 - 0.5336i
0.7743	-0.7873 + 0.9642i
1.2915	-1.1471 - 0.0200i
2.1544	-0.8095 - 0.7982i
3.5938	1.4384 - 0.1332i
5.9948	-0.7549 + 1.3514i
10.0000	-1.7115 - 0.5890i

Continuous-time frequency response.

Frequency-Response Data Model with Negative Frequencies

You can specify negative frequency values in an frd object. This capability is useful when you want to capture the frequency response data of models with complex coefficients.

Create a frequency vector with both positive and negative values.

```
w0 = sort([-logspace(-2,2,50) 0 logspace(-2,2,50)]);
```

Create a state-space model with complex coefficients.

```
A = [-3.50, -1.25-0.25i; 2, 0];
B = [1; 0];
C = [-0.75-0.5i, 0.625-0.125i];
D = 0.5;
Gc = ss(A,B,C,D);
```

Convert the model to an frd model at the specified frequencies.

```
sys = frd(Gc,w0);
```

Plot the frequency response of the models.

```
bode(Gc, 'b', sys, 'r--')
```

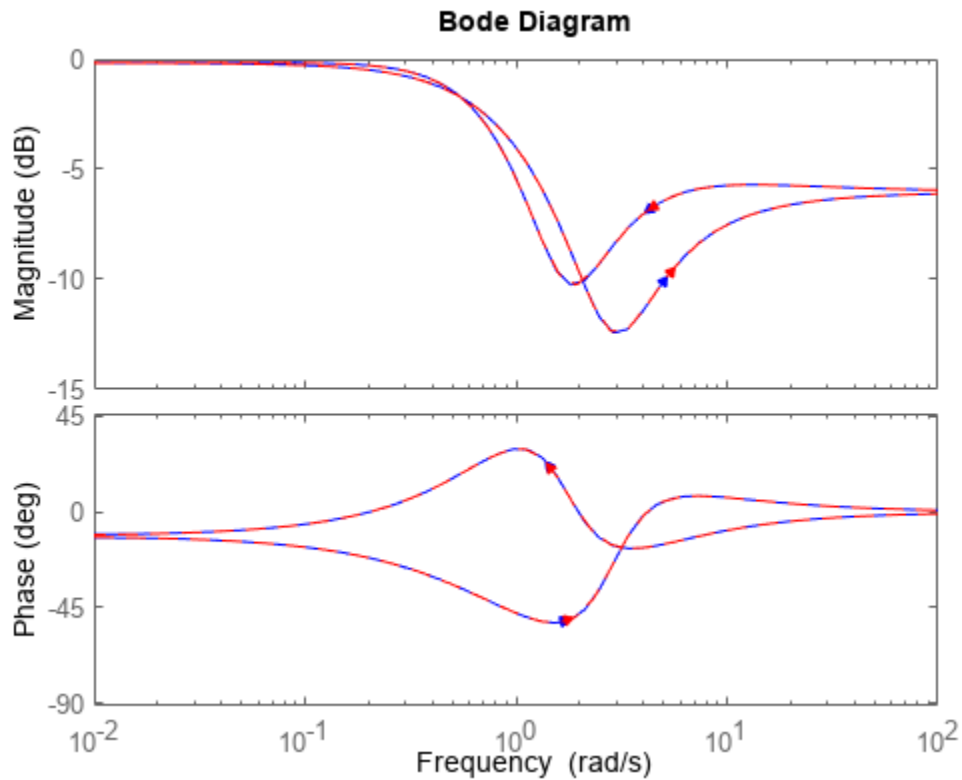

The plot responses match closely. The plot shows two branches for models with complex coefficients, one for positive frequencies, with a right-pointing arrow, and one for negative frequencies, with a left-pointing arrow. In both branches, the arrows indicate the direction of increasing frequencies.

Version History

Introduced before R2006a

See Also

`get` | `set` | `ss` | `zpk` | `tf` | `frdata` | `genfrd` | `frdfun` | `bode` | `pidtune`

Topics

"Frequency Response Data (FRD) Models"

"What Are Model Objects?"

"MIMO Frequency Response Data Models"

frdata

Access data for frequency response data (FRD) object

Syntax

```
[response,freq] = frdata(sys)
[response,freq,covresp] = frdata(sys)
[response,freq,Ts,covresp] = frdata(sys,'v')
[response,freq,Ts] = frdata(sys)
```

Description

`[response,freq] = frdata(sys)` returns the response data and frequency samples of the FRD model `sys`. For an FRD model with `Ny` outputs and `Nu` inputs at `Nf` frequencies:

- `response` is an `Ny`-by-`Nu`-by-`Nf` multidimensional array where the (i,j) entry specifies the response from input `j` to output `i`.
- `freq` is a column vector of length `Nf` that contains the frequency samples of the FRD model.

See the `frd` reference page for more information on the data format for FRD response data.

`[response,freq,covresp] = frdata(sys)` also returns the covariance `covresp` of the response data `resp` for `idfrd` model `sys`. (Using `idfrd` models requires System Identification Toolbox software.) The covariance `covresp` is a 5D-array where `covH(i,j,k,:,:)` contains the 2-by-2 covariance matrix of the response `resp(i,j,k)`. The $(1,1)$ element is the variance of the real part, the $(2,2)$ element the variance of the imaginary part and the $(1,2)$ and $(2,1)$ elements the covariance between the real and imaginary parts.

For SISO FRD models, the syntax

```
[response,freq] = frdata(sys,'v')
```

forces `frdata` to return the response data as a column vector rather than a 3-dimensional array (see example below). Similarly

```
[response,freq,Ts,covresp] = frdata(sys,'v')
```

for an IDFRD model `sys` returns `covresp` as a 3-dimensional rather than a 5-dimensional array.

```
[response,freq,Ts] = frdata(sys)
```

also returns the sample time `Ts`.

Other properties of `sys` can be accessed with `get` or by direct structure-like referencing (e.g., `sys.Frequency`).

Arguments

The input argument `sys` to `frdata` must be an FRD model.

Examples

Extract Data from Frequency Response Data Model

Create a frequency response data model by computing the response of a transfer function on a grid of frequencies.

```
H = tf([-1.2, -2.4, -1.5], [1, 20, 9.1]);  
w = logspace(-2, 3, 101);  
sys = frd(H, w);
```

`sys` is a SISO frequency response data (`frd`) model containing the frequency response at 101 frequencies.

Extract the frequency response data from `sys`.

```
[response, freq] = frdata(sys);
```

`response` is a 1-by-1-by-101 array. `response(1, 1, k)` is the complex frequency response at the frequency `freq(k)`.

Version History

Introduced before R2006a

See Also

`frd` | `get` | `set` | `freqresp`

freqresp

Evaluate system response over a grid of frequencies

Syntax

```
[H,wout] = freqresp(sys)
H = freqresp(sys,w)
H = freqresp(sys,w,units)
[H,wout,covH] = freqresp(sys, ___)
```

Description

Use `freqresp` to evaluate the system response over a grid of frequencies. To obtain the magnitude and phase data as well as plots of the frequency response, use `bode` instead.

`[H,wout] = freqresp(sys)` returns the frequency response of the dynamic system model `sys` at frequencies `wout`. `freqresp` automatically determines the frequencies based on the dynamics of `sys`. For more information about frequency response, see “Frequency Response” on page 2-319.

`H = freqresp(sys,w)` returns the frequency response on the real frequency grid specified by the vector `w`.

`H = freqresp(sys,w,units)` explicitly specifies the frequency units of `w` with `units`.

`[H,wout,covH] = freqresp(sys, ___)` also returns the covariance `covH` of the frequency response. Use this syntax only when `sys` is an identified model of one of the types listed in “Identified LTI Models”.

Examples

Frequency Response of SISO System

For this example, consider the following SISO state-space model:

$$A = \begin{bmatrix} -1.5 & -2 \\ 1 & 0 \end{bmatrix} \quad B = \begin{bmatrix} 0.5 \\ 0 \end{bmatrix} \quad C = [0 \ 1] \quad D = 0$$

Create the SISO state-space model defined by the following state-space matrices:

```
A = [-1.5, -2; 1, 0];
B = [0.5; 0];
C = [0, 1];
D = 0;
sys = ss(A,B,C,D);
```

Compute the frequency response of the system.

```
[H,wout] = freqresp(sys);
size(H)
```

```
ans = 1×3
      1      1      56
```

H contains the frequency response at 56 frequencies that are automatically chosen based on the dynamics of `sys`.

```
size(wout)
```

```
ans = 1×2
      56      1
```

`wout` contains the corresponding 56 frequencies.

Compute Frequency Response of System

Create the following 2-input, 2-output system:

$$\text{sys} = \begin{bmatrix} 0 & \frac{1}{s+1} \\ \frac{s-1}{s+2} & 1 \end{bmatrix}$$

```
sys11 = 0;
sys22 = 1;
sys12 = tf(1,[1 1]);
sys21 = tf([1 -1],[1 2]);
sys = [sys11,sys12;sys21,sys22];
```

Compute the frequency response of the system.

```
[H,wout] = freqresp(sys);
```

H is a 2-by-2-by-45 array. Each entry $H(:, :, k)$ in H is a 2-by-2 matrix giving the complex frequency response of all input-output pairs of `sys` at the corresponding frequency `wout(k)`. The 45 frequencies in `wout` are automatically selected based on the dynamics of `sys`.

Compute Frequency Response on Specified Frequency Grid

Create the following 2-input, 2-output system:

$$\text{sys} = \begin{bmatrix} 0 & \frac{1}{s+1} \\ \frac{s-1}{s+2} & 1 \end{bmatrix}$$

```
sys11 = 0;
sys22 = 1;
```

```
sys12 = tf(1,[1 1]);
sys21 = tf([1 -1],[1 2]);
sys = [sys11,sys12;sys21,sys22];
```

Create a logarithmically-spaced grid of 200 frequency points between 10 and 100 radians per second.

```
w = logspace(1,2,200);
```

Compute the frequency response of the system on the specified frequency grid.

```
H = freqresp(sys,w);
```

H is a 2-by-2-by-200 array. Each entry $H(:, :, k)$ in H is a 2-by-2 matrix giving the complex frequency response of all input-output pairs of `sys` at the corresponding frequency $w(k)$.

Compute Frequency Response and Associated Covariance

Compute the frequency response and associated covariance for an identified process model at its peak response frequency.

Load estimation data `z1`.

```
load iddata1 z1
```

Estimate a SISO process model using the data.

```
model = procest(z1,'P2UZ');
```

Compute the frequency at which the model achieves the peak frequency response gain. To get a more accurate result, specify a tolerance value of $1e-6$.

```
[gpeak,fpeak] = getPeakGain(model,1e-6);
```

Compute the frequency response and associated covariance for `model` at its peak response frequency.

```
[H,wout,covH] = freqresp(model,fpeak);
```

H is the response value at `fpeak` frequency, and `wout` is the same as `fpeak`.

`covH` is a 5-dimensional array that contains the covariance matrix of the response from the input to the output at frequency `fpeak`. Here `covH(1,1,1,1,1)` is the variance of the real part of the response, and `covH(1,1,1,2,2)` is the variance of the imaginary part. The `covH(1,1,1,1,2)` and `covH(1,1,1,2,1)` elements are the covariance between the real and imaginary parts of the response.

Input Arguments

sys — Dynamic system

dynamic system model | model array

Dynamic system, specified as a SISO or MIMO dynamic system model or array of dynamic system models. Dynamic systems that you can use include:

- LTI models such as `ss`, `tf`, and `zpk` models.
- Sparse state-space models, such as `sparss` or `mechss` models.
- Generalized or uncertain state-space models such as `genss` or `uss` models. (Using uncertain models requires Robust Control Toolbox software.)
 - For tunable control design blocks, the function evaluates the model at its current value to evaluate the frequency response.
 - For uncertain control design blocks, the function evaluates the frequency response at the nominal value and random samples of the model.
- Identified state-space models, such as `idss` models. (Using identified models requires System Identification Toolbox software.)

For a complete list of models, see “Dynamic System Models”.

w — Frequency values to evaluate system response

vector of scalar values | vector of complex values

Frequency values to evaluate system response, specified as either a vector of scalar values or a vector of complex values. Specify frequencies in units of `rad/TimeUnit`, where `TimeUnit` is the time units specified in the `TimeUnit` property of `sys`.

You can specify the frequency in terms of the Laplace variable `s` or `z` based on whether `sys` is a continuous-time or discrete-time model, respectively. For instance, if you want to evaluate the frequency response of a system `sys` at a frequency value of `w` rad/s, then specify the values in terms of

- $s = jw$, if `sys` is in continuous-time.
- $z = e^{jwT}$, if `sys` is in discrete-time. Here, `T` is the sample time.

units — Units of the values in the input frequency vector

`rad/TimeUnit` (default) | `'cycles/TimeUnit'` | `'rad/s'` | ...

Units of the frequencies in the input frequency vector `w`, specified as one of the following values:

- `'rad/TimeUnit'` — radians per the time unit specified in the `TimeUnit` property of `sys`
- `'cycles/TimeUnit'` — cycles per the time unit specified in the `TimeUnit` property of `sys`
- `'rad/s'`
- `'Hz'`
- `'kHz'`
- `'MHz'`
- `'GHz'`
- `'rpm'`

Output Arguments

H — Frequency response values

array

Frequency response values, returned as an array.

When `sys` is

- An individual dynamic system model with N_y outputs and N_u inputs, `H` is a 3D array with dimensions N_y -by- N_u -by- N_w , where N_w is the number of frequency points. Thus, `H(:, :, k)` is the response at the frequency $w(k)$ or `wout(k)`.
- A model array of size `[Ny Nu S1 . . . Sn]`, `H` is an array with dimensions N_y -by- N_u -by- N_w -by- S_1 -by-...-by- S_n array.
- A frequency response data model (such as `frd`, `genfrd`, or `idfrd`), `freqresp(sys, w)` evaluates to `NaN` for values of w falling outside the frequency interval defined by `sys.frequency`. The `freqresp` command can interpolate between frequencies in `sys.frequency`. However, `freqresp` cannot extrapolate beyond the frequency interval defined by `sys.frequency`.

wout — Output frequencies corresponding to the frequency response

vector

Output frequencies corresponding to the frequency response `H`, returned as a vector. When you omit `w` from the inputs to `freqresp`, the command automatically determines the frequencies of `wout` based on the system dynamics. If you specify `w`, then `wout = w`

covH — Covariance of the frequency response

array

Covariance of the frequency response, returned as a 5D array. For instance, `covH(i, j, k, :, :)` contains the 2-by-2 covariance matrix of the response from the i th input to the j th output at frequency $w(k)$. The (1,1) element of this 2-by-2 matrix is the variance of the real part of the response. The (2,2) element is the variance of the imaginary part. The (1,2) and (2,1) elements are the covariance between the real and imaginary parts of the response.

More About

Frequency Response

In continuous time, the frequency response at a frequency ω is the transfer function value at $s = j\omega$. For state-space models, this value is given by

$$H(j\omega) = D + C(j\omega I - A)^{-1}B$$

In discrete time, the frequency response is the transfer function evaluated at points on the unit circle that correspond to the real frequencies. `freqresp` maps the real frequencies `w(1), ..., w(N)` to points on the unit circle using the transformation $z = e^{j\omega T_s}$. T_s is the sample time. The function returns the values of the transfer function at the resulting z values. For models with unspecified sample time, `freqresp` uses $T_s = 1$.

Algorithms

For transfer functions or zero-pole-gain models, `freqresp` evaluates the numerator(s) and denominator(s) at the specified frequency points. For continuous-time state-space models (A, B, C, D), the frequency response is

$$D + C(j\omega - A)^{-1}B, \quad \omega = \omega_1, \dots, \omega_N$$

For efficiency, A is reduced to upper Hessenberg form and the linear equation $(j\omega - A)X = B$ is solved at each frequency point, taking advantage of the Hessenberg structure. The reduction to Hessenberg

form provides a good compromise between efficiency and reliability. For more details on this technique, see [1].

Version History

Introduced before R2006a

References

[1] Laub, A.J., "Efficient Multivariable Frequency Response Computations," *IEEE Transactions on Automatic Control*, AC-26 (1981), pp. 407-408.

See Also

`evalfr` | `bode` | `nyquist` | `nichols` | `sigma` | `interp` | `spectrum`

frdfun

Apply a function to the frequency response value at each frequency of an `frd` model object

Syntax

```
fsys = frdfun(fun,sys)
```

Description

`fsys = frdfun(fun,sys)` applies the function `fun` to the frequency response value at each frequency of `sys` and collects the results in `fsys`.

Examples

Apply Functions to Frequency Response Model

For this example, create a frequency response data model by computing the response of a transfer function on a grid of frequencies. For this example, assume a set of 10 frequencies.

```
H = tf([-1.2, -2.4, -1.5], [1, 20, 9.1]);
w = logspace(-2, 3, 10);
sys = frd(H, w)
```

```
sys =
```

Frequency (rad/s)	Response
-----	-----
0.0100	-0.1648 + 9.847e-04i
0.0359	-0.1644 + 3.508e-03i
0.1292	-0.1597 + 1.130e-02i
0.4642	-0.1294 + 9.857e-03i
1.6681	-0.1058 - 7.515e-02i
5.9948	-0.1883 - 3.050e-01i
21.5443	-0.7004 - 5.495e-01i
77.4264	-1.1337 - 2.623e-01i
278.2559	-1.1946 - 7.725e-02i
1000.0000	-1.1996 - 2.159e-02i

Continuous-time frequency response.

`sys` is a SISO frequency response data (`frd`) model containing the frequency response at 10 frequencies.

Use the `frdfun` command to apply the function `imag` on the `frd` model `sys` to obtain the imaginary parts of the frequency response as a function of frequency.

```
sysImag = frdfun(@imag, sys)
```

```
sysImag =
```

Frequency (rad/s)	Response
-------------------	----------

```

-----
    0.0100    9.847e-04
    0.0359    3.508e-03
    0.1292    1.130e-02
    0.4642    9.857e-03
    1.6681   -7.515e-02
    5.9948   -3.050e-01
   21.5443   -5.495e-01
   77.4264   -2.623e-01
  278.2559   -7.725e-02
 1000.0000   -2.159e-02

```

Continuous-time frequency response.

You can also obtain the magnitude of the frequency response of `sys` with the `abs` function.

```
sysMag = frdfun(@abs,sys)
```

```
sysMag =
```

Frequency (rad/s)	Response
-----	-----
0.0100	0.1648
0.0359	0.1644
0.1292	0.1601
0.4642	0.1298
1.6681	0.1298
5.9948	0.3585
21.5443	0.8902
77.4264	1.1637
278.2559	1.1971
1000.0000	1.1998

Continuous-time frequency response.

Magnitude of Specific I/O Pairs in MIMO Frequency Response Model

For this example, consider a 2x2 MIMO frequency response model `sys` that contains 100 test frequencies for each I/O pair.

Load the `frd` object `sys` from the MAT-file `frdModelMIMO.mat`.

```
load('frdModelMIMO.mat','sys')
size(sys)
```

FRD model with 2 outputs, 2 inputs, and 100 frequency points.

Define a function to compute the magnitude of the frequency response of the second I/O pair in `sys`.

```
fun = @(h) abs(h(2,2));
```

Use the `frdfun` command to apply the function `fun` to the specific I/O pair in `sys`.

```
fsys = frdfun(fun,sys);
```

Input Arguments

fun — Function to be applied to frd model

MATLAB function

Function to be applied to frd model, specified as a MATLAB function. The function fun must accept a single matrix and return a scalar, vector, or matrix of fixed size across frequency.

sys — Frequency response data model

frd model object | genfrd model object | ufrd model object

Frequency response data model, specified as an frd, genfrd, or ufrd model object. When you specify sys as a genfrd or ufrd object, frdfun converts it to an frd object first before applying the function fun.

For more information on frequency response data models, see frd.

Output Arguments

fsys — Output frequency response data model

frd model object

Output frequency response data model, returned as an frd model object. frdfun applies the function fun to the frequency response value at each frequency of sys and collects the results in fsys.

For more information on frequency response data models, see frd.

Version History

Introduced in R2020a

See Also

frd | genfrd | ufrd

freqsep

Slow-fast decomposition

Syntax

```
[Gs,Gf] = freqsep(G,fcut)  
[Gs,Gf] = freqsep(G,fcut,options)
```

Description

`[Gs,Gf] = freqsep(G,fcut)` decomposes a linear dynamic system into slow and fast components around the specified cutoff frequency. The decomposition is such that $G = G_s + G_f$.

`[Gs,Gf] = freqsep(G,fcut,options)` specifies additional options for the decomposition.

Examples

Decompose Model into Fast and Slow Dynamics

Load a dynamic system model.

```
load numdemo Pd  
bode(Pd)
```

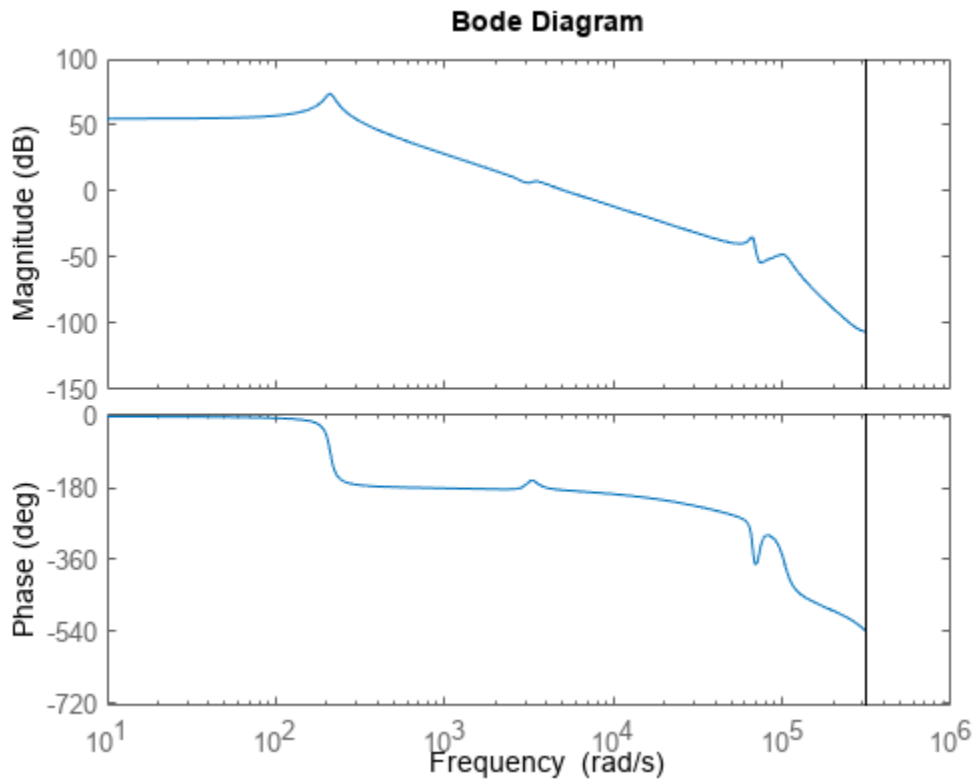

Pd has four complex poles and one real pole. The Bode plot shows a resonance around 210 rad/s and a higher-frequency resonance below 10,000 rad/s.

Decompose this model around 1000 rad/s to separate these two resonances.

```
[Gs,Gf] = freqsep(Pd,10^3);
bode(Pd,Gs,Gf)
legend('original','slow','fast','Location','Southwest')
```

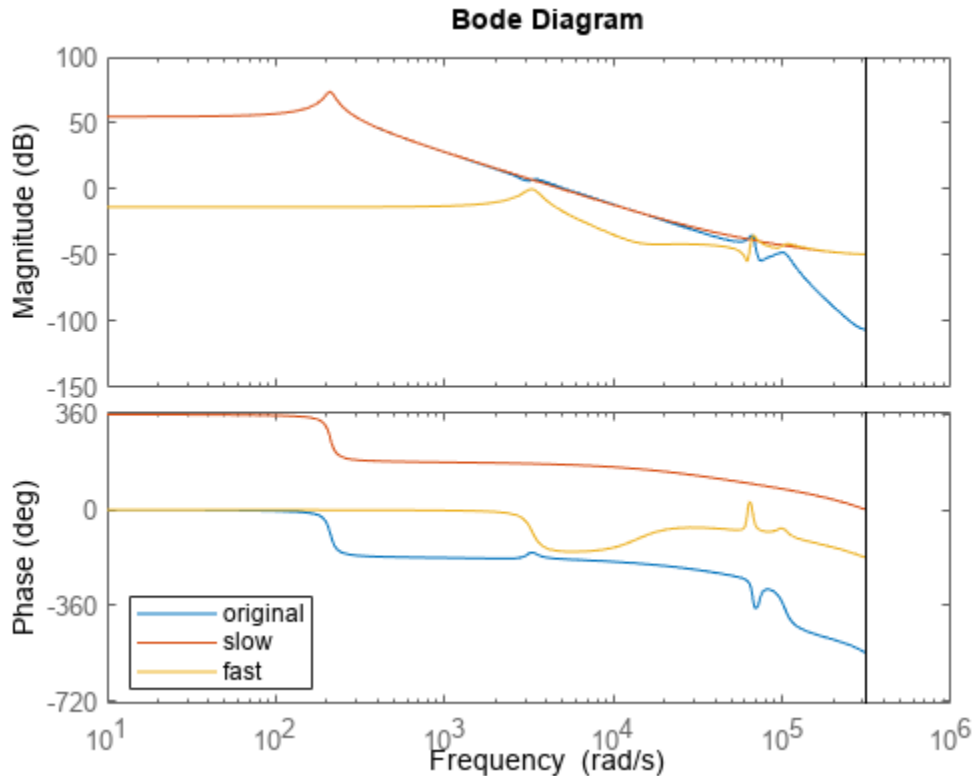

The Bode plot shows that the slow component, G_s , contains only the lower-frequency resonance. This component also matches the DC gain of the original model. The fast component, G_f , contains the higher-frequency resonances and matches the response of the original model at high frequencies. The sum of the two components G_s+G_f yields the original model.

Separate Nearby Modes by Adjusting Tolerance

Decompose a model into slow and fast components between poles that are closely spaced.

The following system includes a real pole and a complex pair of poles that are all close to $s = -2$.

```
G = zpk(-.5, [-1.9999 -2+1e-4i -2-1e-4i], 10);
```

Try to decompose the model about 2 rad/s, so that the slow component contains the real pole and the fast component contains the complex pair.

```
[Gs,Gf] = freqsep(G,2);
```

Warning: One or more fast modes could not be separated from the slow modes. To force separation,

These poles are too close together for `freqsep` to separate. Increase the relative tolerance to allow the separation.

```
options = freqsepOptions('SepTol',5e10);
[Gs,Gf] = freqsep(G,2,options);
```

Now freqsep successfully separates the dynamics.

```
slowpole = pole(Gs)
slowpole = -1.9999
fastpole = pole(Gf)
fastpole = 2×1 complex
  -2.0000 + 0.0001i
  -2.0000 - 0.0001i
```

Input Arguments

G — Dynamic system to decompose

numeric LTI model

Dynamic system to decompose, specified as a numeric LTI model, such as a `ss` or `tf` model.

fcut — Cutoff frequency

positive scalar

Cutoff frequency for fast-slow decomposition, specified as a positive scalar. The output `Gs` contains all poles with natural frequency less than `fcut`. The output `Gf` contains all poles with natural frequency greater than or equal to `fcut`.

options — Options for decomposition

`freqsepOptions` options set

Options for the decomposition, specified as an options set you create with `freqsepOptions`. Available options include absolute and relative tolerance for accuracy of the decomposed systems.

Output Arguments

Gs — Slow dynamics

numeric LTI model

Slow dynamics of the decomposed system, returned as a numeric LTI model of the same type as `G`. `Gs` contains all poles of `G` with natural frequency less than `fcut`, and is such that $G = G_s + G_f$.

Gf — Fast dynamics

numeric LTI model

Fast dynamics of the decomposed system, returned as a numeric LTI model of the same type as `G`. `Gf` contains all poles of `G` with natural frequency greater than or equal to `fcut`, and is such that $G = G_s + G_f$.

Alternative Functionality

App

Model Reducer

Live Editor Task

Reduce Model Order

Version History

Introduced in R2014a

See Also

freqsepOptions | **Model Reducer** | **Reduce Model Order**

Topics

“Model Reduction Basics”

“Mode-Selection Model Reduction”

freqsepOptions

Options for slow-fast decomposition

Syntax

```
opt = freqsepOptions
opt = freqsepOptions(Name,Value)
```

Description

`opt = freqsepOptions` returns the default options for `freqsep`.

`opt = freqsepOptions(Name,Value)` returns an options set with the options specified by one or more `Name,Value` pair arguments.

Examples

Separate Nearby Modes by Adjusting Tolerance

Decompose a model into slow and fast components between poles that are closely spaced.

The following system includes a real pole and a complex pair of poles that are all close to $s = -2$.

```
G = zpk(-.5,[-1.9999 -2+1e-4i -2-1e-4i],10);
```

Try to decompose the model about 2 rad/s, so that the slow component contains the real pole and the fast component contains the complex pair.

```
[Gs,Gf] = freqsep(G,2);
```

Warning: One or more fast modes could not be separated from the slow modes. To force separation,

These poles are too close together for `freqsep` to separate. Increase the relative tolerance to allow the separation.

```
options = freqsepOptions('SepTol',5e10);
[Gs,Gf] = freqsep(G,2,options);
```

Now `freqsep` successfully separates the dynamics.

```
slowpole = pole(Gs)
```

```
slowpole = -1.9999
```

```
fastpole = pole(Gf)
```

```
fastpole = 2×1 complex
```

```
-2.0000 + 0.0001i
-2.0000 - 0.0001i
```

Input Arguments

Name-Value Pair Arguments

Specify optional pairs of arguments as `Name1=Value1, ..., NameN=ValueN`, where `Name` is the argument name and `Value` is the corresponding value. Name-value arguments must appear after other arguments, but the order of the pairs does not matter.

Before R2021a, use commas to separate each name and value, and enclose `Name` in quotes.

Example: `'SepTol',5`

SepTol — Accuracy loss factor

10 (default) | nonnegative scalar

Accuracy loss factor for slow-fast decomposition, specified as a nonnegative scalar value. `freqresp` ensures that the frequency responses of the original system, `G`, and the sum of the decomposed systems `G1+G2`, differ by no more than `SepTol` times the absolute accuracy of the computed value of `G(s)`. Increasing `SepTol` helps separate modes straddling the slow/fast boundary at the expense of accuracy.

Output Arguments

opt — Options for `freqsep`

`freqsepOptions` options set

Options for `freqsep`, returned as a `freqsepOptions` options set. Use `opt` as the last argument to `freqsep` when computing slow-fast decomposition.

Version History

Introduced in R2014a

See Also

`freqsep`

fselect

Select frequency points or range in FRD model

Syntax

```
subsys = fselect(sys, fmin, fmax)
subsys = fselect(sys, index)
```

Description

`subsys = fselect(sys, fmin, fmax)` takes an FRD model `sys` and selects the portion of the frequency response between the frequencies `fmin` and `fmax`. The selected range `[fmin, fmax]` should be expressed in the FRD model units. For an IDFRD model (requires System Identification Toolbox software), the `SpectrumData`, `CovarianceData` and `NoiseCovariance` values, if non-empty, are also selected in the chosen range.

`subsys = fselect(sys, index)` selects the frequency points specified by the vector of indices `index`. The resulting frequency grid is

```
sys.Frequency(index)
```

Version History

Introduced before R2006a

See Also

`interp` | `fcat` | `fdel` | `frd`

full

Convert sparse models to dense storage

Syntax

```
fsys = full(sys)
```

Description

`fsys = full(sys)` converts the `sparss` and `mechss` model `sys` to dense state-space representation `ss`. For `mechss` models, the conversion to dense representation is equivalent to `full(sparss(sys))`. For other model types, `full` leaves `sys` unchanged.

Use the `full` command to convert small scale sparse models to dense storage to perform operations like pole/zero extraction, model order reduction, and controller design and tuning. Converting to dense storage is not recommended for large scale sparse models as it may saturate available memory and cause severe performance degradation.

Examples

Convert Sparse Second-Order Model to Dense Representation

For this example, consider `sparseS0Full.mat` that contains a sparse second-order model with 50 nodes.

Load the sparse second-order model and convert it to dense representation using `full`.

```
load('sparseS0Full.mat','sys');  
fsys = full(sys);  
size(fsys)
```

State-space model with 1 outputs, 1 inputs, and 100 states.

Since, `sys` is a `mechss` model, the conversion to dense storage is equivalent to `fsys = full(sparss(sys))`. The resultant model `fsys` is a full storage `ss` model object with 100 states since the mass matrix is full rank.

Compare the storage size of the two representations.

`whos`

Name	Size	Bytes	Class	Attributes
<code>fsys</code>	1x1	162930	<code>ss</code>	
<code>sys</code>	1x1	6576	<code>mechss</code>	<code>sparse</code>

Converting to dense storage is not recommended for large scale sparse models as it may saturate available memory and cause severe performance degradation.

Input Arguments

sys — Sparse state-space model

`sparss` model object | `mechss` model object

Sparse state-space model, specified as a `sparss` or `mechss` model object. For other model types, `full` leaves `sys` unchanged.

Output Arguments

fsys — Dense state-space model

`ss` model object

Dense state-space model, returned as an `ss` model object. For more information on dense state-space model representation, see `ss`.

Version History

Introduced in R2020b

See Also

`sparss` | `mechss` | `ss`

Topics

“Sparse Model Basics”

gcare

(Not recommended) Generalized solver for continuous-time algebraic Riccati equation

Note `gcare` is not recommended. Use `icare` instead. For more information, see “Compatibility Considerations”.

Syntax

```
[X,L,report] = gcare(H,J,ns)
[X1,X2,D,L] = gcare(H,...,'factor')
```

Description

`[X,L,report] = gcare(H,J,ns)` computes the unique stabilizing solution X of the continuous-time algebraic Riccati equation associated with a Hamiltonian pencil of the form

$$H - tJ = \begin{bmatrix} A & F & S1 \\ G & -A' & -S2 \\ S2' & S1' & R \end{bmatrix} - \begin{bmatrix} E & 0 & 0 \\ 0 & E' & 0 \\ 0 & 0 & 0 \end{bmatrix}$$

The optional input `ns` is the row size of the A matrix. Default values for J and `ns` correspond to $E = I$ and $R = []$.

Optionally, `gcare` returns the vector L of closed-loop eigenvalues and a diagnosis report with value:

- -1 if the Hamiltonian pencil has jw -axis eigenvalues
- -2 if there is no finite stabilizing solution X
- 0 if a finite stabilizing solution X exists

This syntax does not issue any error message when X fails to exist.

`[X1,X2,D,L] = gcare(H,...,'factor')` returns two matrices $X1$, $X2$ and a diagonal scaling matrix D such that $X = D*(X2/X1)*D$. The vector L contains the closed-loop eigenvalues. All outputs are empty when the associated Hamiltonian matrix has eigenvalues on the imaginary axis.

Version History

Introduced before R2006a

gcare is not recommended

Not recommended starting in R2019a

Starting in R2019a, use the `icare` command to solve continuous-time Riccati equations. This approach has improved accuracy through better scaling and the computation of K is more accurate when R is ill-conditioned relative to `gcare`. Furthermore, `icare` includes an optional `info` structure to gather the implicit solution data of the Riccati equation.

The following table shows some typical uses of `gcare` and how to update your code to use `icare` instead.

Not Recommended	Recommended
<code>[X,L] = gcare(H,J,NS)</code>	<code>[X,K,L] = icare(A,B,Q,R,S,E,G)</code> computes the stabilizing solution <code>X</code> , the state-feedback gain <code>K</code> and the closed-loop eigenvalues <code>L</code> of the continuous-time algebraic Riccati equation. For more information, see <code>icare</code> .
<code>[X,L,report] = gcare(H,J,NS)</code>	<code>[X,K,L,info] = icare(A,B,Q,R,S,E,G)</code> computes the stabilizing solution <code>X</code> , the state-feedback gain <code>K</code> , the closed-loop eigenvalues <code>L</code> of the continuous-time algebraic Riccati equation. The <code>info</code> structure contains the implicit solution data. For more information, see <code>icare</code> .

There are no plans to remove `gcare` at this time.

See Also

`icare`

gdare

(Not recommended) Generalized solver for discrete-time algebraic Riccati equation

Note `gdare` is not recommended. Use `idare` instead. For more information, see “Compatibility Considerations”.

Syntax

```
[X,L,report] = gdare(H,J,ns)
[X1,X2,D,L] = gdare(H,J,NS,'factor')
```

Description

`[X,L,report] = gdare(H,J,ns)` computes the unique stabilizing solution X of the discrete-time algebraic Riccati equation associated with a Symplectic pencil of the form

$$H - tJ = \begin{bmatrix} A & F & B \\ -Q & E' & -S \\ S' & 0 & R \end{bmatrix} - \begin{bmatrix} E & 0 & 0 \\ 0 & A' & 0 \\ 0 & B' & 0 \end{bmatrix}$$

The third input `ns` is the row size of the A matrix.

Optionally, `gdare` returns the vector `L` of closed-loop eigenvalues and a diagnosis `report` with value:

- -1 if the Symplectic pencil has eigenvalues on the unit circle
- -2 if there is no finite stabilizing solution X
- 0 if a finite stabilizing solution X exists

This syntax does not issue any error message when X fails to exist.

`[X1,X2,D,L] = gdare(H,J,NS,'factor')` returns two matrices $X1$, $X2$ and a diagonal scaling matrix D such that $X = D*(X2/X1)*D$. The vector `L` contains the closed-loop eigenvalues. All outputs are empty when the Symplectic pencil has eigenvalues on the unit circle.

Version History

Introduced before R2006a

gdare not recommended

Not recommended starting in R2019a

Starting in R2019a, use the `idare` command to solve discrete-time Riccati equations. This approach has improved accuracy through better scaling and the computation of K is more accurate when R is ill-conditioned relative to `gdare`. Furthermore, `idare` includes an optional `info` structure to gather the implicit solution data of the Riccati equation.

The following table shows some typical uses of `gdare` and how to update your code to use `idare` instead.

Not Recommended	Recommended
[X,L] = gdare(H,J,NS)	[X,K,L] = idare(A,B,Q,R,S,E) computes the stabilizing solution X, the state-feedback gain K and the closed-loop eigenvalues L of the discrete-time algebraic Riccati equation. For more information, see idare.
[X,L,report] = gdare(H,J,NS)	[X,K,L,info] = idare(A,B,Q,R,S,E) computes the stabilizing solution X, the state-feedback gain K, the closed-loop eigenvalues L of the discrete-time algebraic Riccati equation. The info structure contains the implicit solution data. For more information, see idare.

There are no plans to remove gdare at this time.

See Also

idare

genfrd

Generalized frequency response data (FRD) model

Description

Generalized FRD (`genfrd`) models arise when you combine numeric FRD models with models containing tunable components (Control Design Blocks). `genfrd` models keep track of how the tunable blocks interact with the tunable components. For more information about Control Design Blocks, see “Generalized Models”.

Construction

To construct a `genfrd` model, use `series`, `parallel`, `lft`, or `connect`, or the arithmetic operators `+`, `-`, `*`, `/`, `\`, and `^`, to combine a numeric FRD model with control design blocks.

You can also convert any numeric LTI model or control design block `sys` to `genfrd` form.

`frdsys = genfrd(sys, freqs, frequits)` converts any static model or dynamic system `sys` to a generalized FRD model. If `sys` is not an `frd` model object, `genfrd` computes the frequency response of each frequency point in the vector `freqs`. The frequencies `freqs` are in the units specified by the optional argument `frequits`. If `frequits` is omitted, the units of `freqs` are `'rad/TimeUnit'`.

`frdsys = genfrd(sys, freqs, frequits, timeunits)` further specifies the time units for converting `sys` to `genfrd` form.

For more information about time and frequency units of `genfrd` models, see “Properties” on page 2-339.

Input Arguments

`sys`

A static model or dynamic system model object.

`freqs`

Vector of frequency points. Express frequencies in the unit specified in `frequits`.

`frequits`

Frequency units of the `genfrd` model, specified as one of the following values:

- `'rad/TimeUnit'`
- `'cycles/TimeUnit'`
- `'rad/s'`
- `'Hz'`
- `'kHz'`
- `'MHz'`

- 'GHz'
- 'rpm'

Default: 'rad/TimeUnit'

timeunits

Time units of the genfrd model, specified as one of the following values:

- 'nanoseconds'
- 'microseconds'
- 'milliseconds'
- 'seconds'
- 'minutes'
- 'hours'
- 'days'
- 'weeks'
- 'months'
- 'years'

Default: 'seconds'

Properties

Blocks

Structure containing the control design blocks included in the generalized LTI model or generalized matrix. The field names of `Blocks` are the `Name` property of each control design block.

You can change some attributes of these control design blocks using dot notation. For example, if the generalized LTI model or generalized matrix `M` contains a `realp` tunable parameter `a`, you can change the current value of `a` using:

```
M.Blocks.a.Value = -1;
```

Frequency

Frequency points of the frequency response data. Specify `Frequency` values in the units specified by the `FrequencyUnit` property.

FrequencyUnit

Frequency units of the model.

`FrequencyUnit` specifies the units of the frequency vector in the `Frequency` property. Set `FrequencyUnit` to one of the following values:

- 'rad/TimeUnit'
- 'cycles/TimeUnit'
- 'rad/s'

- 'Hz'
- 'kHz'
- 'MHz'
- 'GHz'
- 'rpm'

The units 'rad/TimeUnit' and 'cycles/TimeUnit' are relative to the time units specified in the TimeUnit property.

Changing this property changes the overall system behavior. Use `chgFreqUnit` to convert between frequency units without modifying system behavior.

Default: 'rad/TimeUnit'

InputDelay

Input delay for each input channel, specified as a scalar value or numeric vector. For continuous-time systems, specify input delays in the time unit stored in the TimeUnit property. For discrete-time systems, specify input delays in integer multiples of the sample time Ts. For example, `InputDelay = 3` means a delay of three sample times.

For a system with Nu inputs, set InputDelay to an Nu-by-1 vector. Each entry of this vector is a numerical value that represents the input delay for the corresponding input channel.

You can also set InputDelay to a scalar value to apply the same delay to all channels.

Default: 0

OutputDelay

Output delays. OutputDelay is a numeric vector specifying a time delay for each output channel. For continuous-time systems, specify output delays in the time unit stored in the TimeUnit property. For discrete-time systems, specify output delays in integer multiples of the sample time Ts. For example, `OutputDelay = 3` means a delay of three sampling periods.

For a system with Ny outputs, set OutputDelay to an Ny-by-1 vector, where each entry is a numerical value representing the output delay for the corresponding output channel. You can also set OutputDelay to a scalar value to apply the same delay to all channels.

Default: 0 for all output channels

Ts

Sample time. For continuous-time models, `Ts = 0`. For discrete-time models, Ts is a positive scalar representing the sampling period. This value is expressed in the unit specified by the TimeUnit property of the model. To denote a discrete-time model with unspecified sample time, set `Ts = -1`.

Changing this property does not discretize or resample the model.

Default: 0 (continuous time)

TimeUnit

Units for the time variable, the sample time T_s , and any time delays in the model, specified as one of the following values:

- 'nanoseconds'
- 'microseconds'
- 'milliseconds'
- 'seconds'
- 'minutes'
- 'hours'
- 'days'
- 'weeks'
- 'months'
- 'years'

Changing this property has no effect on other properties, and therefore changes the overall system behavior. Use `chgTimeUnit` to convert between time units without modifying system behavior.

Default: 'seconds'

InputName

Input channel names, specified as one of the following:

- Character vector — For single-input models, for example, 'controls'.
- Cell array of character vectors — For multi-input models.

Alternatively, use automatic vector expansion to assign input names for multi-input models. For example, if `sys` is a two-input model, enter:

```
sys.InputName = 'controls';
```

The input names automatically expand to {'controls(1)'; 'controls(2)'}

You can use the shorthand notation `u` to refer to the `InputName` property. For example, `sys.u` is equivalent to `sys.InputName`.

Input channel names have several uses, including:

- Identifying channels on model display and plots
- Extracting subsystems of MIMO systems
- Specifying connection points when interconnecting models

Default: '' for all input channels

InputUnit

Input channel units, specified as one of the following:

- Character vector — For single-input models, for example, 'seconds'.

- Cell array of character vectors — For multi-input models.

Use `InputUnit` to keep track of input signal units. `InputUnit` has no effect on system behavior.

Default: '' for all input channels

InputGroup

Input channel groups. The `InputGroup` property lets you assign the input channels of MIMO systems into groups and refer to each group by name. Specify input groups as a structure. In this structure, field names are the group names, and field values are the input channels belonging to each group. For example:

```
sys.InputGroup.controls = [1 2];  
sys.InputGroup.noise = [3 5];
```

creates input groups named `controls` and `noise` that include input channels 1, 2 and 3, 5, respectively. You can then extract the subsystem from the `controls` inputs to all outputs using:

```
sys(:, 'controls')
```

Default: Struct with no fields

OutputName

Output channel names, specified as one of the following:

- Character vector — For single-output models. For example, 'measurements'.
- Cell array of character vectors — For multi-output models.

Alternatively, use automatic vector expansion to assign output names for multi-output models. For example, if `sys` is a two-output model, enter:

```
sys.OutputName = 'measurements';
```

The output names automatically expand to {'measurements(1)'; 'measurements(2)'}

You can use the shorthand notation `y` to refer to the `OutputName` property. For example, `sys.y` is equivalent to `sys.OutputName`.

Output channel names have several uses, including:

- Identifying channels on model display and plots
- Extracting subsystems of MIMO systems
- Specifying connection points when interconnecting models

Default: '' for all output channels

OutputUnit

Output channel units, specified as one of the following:

- Character vector — For single-output models. For example, 'seconds'.
- Cell array of character vectors — For multi-output models.

Use `OutputUnit` to keep track of output signal units. `OutputUnit` has no effect on system behavior.

Default: '' for all output channels

OutputGroup

Output channel groups. The `OutputGroup` property lets you assign the output channels of MIMO systems into groups and refer to each group by name. Specify output groups as a structure. In this structure, field names are the group names, and field values are the output channels belonging to each group. For example:

```
sys.OutputGroup.temperature = [1];
sys.InputGroup.measurement = [3 5];
```

creates output groups named `temperature` and `measurement` that include output channels 1, and 3, 5, respectively. You can then extract the subsystem from all inputs to the measurement outputs using:

```
sys('measurement', :)
```

Default: Struct with no fields

Name

System name, specified as a character vector. For example, `'system_1'`.

Default: ''

Notes

Any text that you want to associate with the system, stored as a string or a cell array of character vectors. The property stores whichever data type you provide. For instance, if `sys1` and `sys2` are dynamic system models, you can set their `Notes` properties as follows:

```
sys1.Notes = "sys1 has a string.";
sys2.Notes = 'sys2 has a character vector.';
sys1.Notes
sys2.Notes
```

```
ans =
```

```
    "sys1 has a string."
```

```
ans =
```

```
    'sys2 has a character vector.'
```

Default: [0×1 string]

UserData

Any type of data you want to associate with system, specified as any MATLAB data type.

Default: []

SamplingGrid

Sampling grid for model arrays, specified as a data structure.

For model arrays that are derived by sampling one or more independent variables, this property tracks the variable values associated with each model in the array. This information appears when you display or plot the model array. Use this information to trace results back to the independent variables.

Set the field names of the data structure to the names of the sampling variables. Set the field values to the sampled variable values associated with each model in the array. All sampling variables should be numeric and scalar valued, and all arrays of sampled values should match the dimensions of the model array.

For example, suppose you create a 11-by-1 array of linear models, `sysarr`, by taking snapshots of a linear time-varying system at times `t = 0:10`. The following code stores the time samples with the linear models.

```
sysarr.SamplingGrid = struct('time',0:10)
```

Similarly, suppose you create a 6-by-9 model array, `M`, by independently sampling two variables, `zeta` and `w`. The following code attaches the (`zeta,w`) values to `M`.

```
[zeta,w] = ndgrid(<6 values of zeta>,<9 values of w>)
M.SamplingGrid = struct('zeta',zeta,'w',w)
```

When you display `M`, each entry in the array includes the corresponding `zeta` and `w` values.

`M`

```
M(:,:,1,1) [zeta=0.3, w=5] =
```

```
      25
-----
s^2 + 3 s + 25
```

```
M(:,:,2,1) [zeta=0.35, w=5] =
```

```
      25
-----
s^2 + 3.5 s + 25
```

...

For model arrays generated by linearizing a Simulink model at multiple parameter values or operating points, the software populates `SamplingGrid` automatically with the variable values that correspond to each entry in the array. For example, the Simulink Control Design commands `linearize` and `sLinearizer` populate `SamplingGrid` in this way.

Default: []

Tips

- You can manipulate genfrd models as ordinary frd models. Frequency-domain analysis commands such as bode evaluate the model by replacing each tunable parameter with its current value.

Version History

Introduced in R2011a

See Also

frd | frdfun | genss | getValue | chgFreqUnit

Topics

“Models with Tunable Coefficients”

“Generalized Models”

genmat

Generalized matrix with tunable parameters

Description

Generalized matrices (`genmat`) are matrices that depend on tunable parameters (see `realp`). You can use generalized matrices for parameter studies. You can also use generalized matrices for building generalized LTI models (see `genss`) that represent control systems having a mixture of fixed and tunable components.

Construction

Generalized matrices arise when you combine numeric values with static blocks such as `realp` objects. You create such combinations using any of the arithmetic operators `+`, `-`, `*`, `/`, `\`, and `^`. For example, if `a` and `b` are tunable parameters, the expression `M = a + b` is represented as a generalized matrix.

The internal data structure of the `genmat` object `M` keeps track of how `M` depends on the parameters `a` and `b`. The `Blocks` property of `M` lists the parameters `a` and `b`.

`M = genmat(A)` converts the numeric array or tunable parameter `A` into a `genmat` object.

Input Arguments

A

Static control design block, such as a `realp` object.

If `A` is a numeric array, `M` is a generalized matrix of the same dimensions as `A`, with no tunable parameters.

If `A` is a static control design block, `M` is a generalized matrix whose `Blocks` property lists `A` as the only block.

Properties

Blocks

Structure containing the control design blocks included in the generalized LTI model or generalized matrix. The field names of `Blocks` are the `Name` property of each control design block.

You can change some attributes of these control design blocks using dot notation. For example, if the generalized LTI model or generalized matrix `M` contains a `realp` tunable parameter `a`, you can change the current value of `a` using:

```
M.Blocks.a.Value = -1;
```

SamplingGrid

Sampling grid for model arrays, specified as a data structure.

For model arrays that are derived by sampling one or more independent variables, this property tracks the variable values associated with each model in the array. This information appears when you display or plot the model array. Use this information to trace results back to the independent variables.

Set the field names of the data structure to the names of the sampling variables. Set the field values to the sampled variable values associated with each model in the array. All sampling variables should be numeric and scalar valued, and all arrays of sampled values should match the dimensions of the model array.

For example, suppose you create a 11-by-1 array of linear models, `sysarr`, by taking snapshots of a linear time-varying system at times `t = 0:10`. The following code stores the time samples with the linear models.

```
sysarr.SamplingGrid = struct('time',0:10)
```

Similarly, suppose you create a 6-by-9 model array, `M`, by independently sampling two variables, `zeta` and `w`. The following code attaches the (`zeta`,`w`) values to `M`.

```
[zeta,w] = ndgrid(<6 values of zeta>,<9 values of w>)
M.SamplingGrid = struct('zeta',zeta,'w',w)
```

When you display `M`, each entry in the array includes the corresponding `zeta` and `w` values.

`M`

```
M(:,:,1,1) [zeta=0.3, w=5] =
```

```
      25
-----
s^2 + 3 s + 25
```

```
M(:,:,2,1) [zeta=0.35, w=5] =
```

```
      25
-----
s^2 + 3.5 s + 25
```

...

For model arrays generated by linearizing a Simulink model at multiple parameter values or operating points, the software populates `SamplingGrid` automatically with the variable values that correspond to each entry in the array. For example, the Simulink Control Design commands `linearize` and `sLinearizer` populate `SamplingGrid` in this way.

Default: []

Name

System name, specified as a character vector. For example, `'mat_1'`. When you convert a static control design block such as `tunableSurface` to a generalized matrix using `genmat(blk)`, the `Name` property of the block is preserved.

Default: ''

Examples

Generalized Matrix With Two Tunable Parameters

This example shows how to use algebraic combinations of tunable parameters to create the generalized matrix:

$$M = \begin{bmatrix} 1 & a + b \\ 0 & ab \end{bmatrix},$$

where a and b are tunable parameters with initial values -1 and 3 , respectively.

- 1 Create the tunable parameters using `realp`.

```
a = realp('a', -1);
b = realp('b', 3);
```

- 2 Define the generalized matrix using algebraic expressions of a and b .

```
M = [1 a+b; 0 a*b]
```

M is a generalized matrix whose `Blocks` property contains a and b . The initial value of M is $M = [1 \ 2; 0 \ -3]$, from the initial values of a and b .

- 3 (Optional) Change the initial value of the parameter a .

```
M.Blocks.a.Value = -3;
```

- 4 (Optional) Use `double` to display the new value of M .

```
double(M)
```

The new value of M is $M = [1 \ 0; 0 \ -9]$.

Version History

Introduced in R2011a

See Also

`realp` | `genss` | `getValue`

Topics

“Models with Tunable Coefficients”

“Dynamic System Models”

gensig

Create periodic signals for simulating system response with `lsim`

Syntax

```
[u,t] = gensig(type,tau)
[u,t] = gensig(type,tau,Tf)
[u,t] = gensig(type,tau,Tf,Ts)
```

Description

`[u,t] = gensig(type,tau)` generates a unit-amplitude periodic signal with the specified type and period. Use the signal `u` and corresponding time vector `t` to simulate the time response of a single-input dynamic system using `lsim` or `lsimplot` or to obtain response characteristics using `lsiminfo`. To create signals for multi-input systems, use repeated calls to `gensig` and stack the resulting `u` vectors into a matrix. When you use `u` and `t` to simulate a dynamic system model, the software interprets `t` as having the units of the `TimeUnit` property of the model.

`[u,t] = gensig(type,tau,Tf)` generates a signal with a duration of `Tf`. `t` runs from 0 to `Tf` in increments of `tau/64`.

`[u,t] = gensig(type,tau,Tf,Ts)` generates a signal with a sample time of `Ts`. `t` runs from 0 to `Tf` in increments of `Ts`. To generate a signal for simulating a discrete-time model, use this syntax and set `Ts` to the sample time of the model.

Examples

Generate Square Wave

Generate a square wave with a period of 2 s to use for simulating a dynamic system response with `lsim`.

```
tau = 2;
[u,t] = gensig("square",tau);
```

`gensig` returns the signal as the vector `u` and the corresponding time vector `t`. When you do not specify the duration of the signal, `gensig` generates a signal that runs for five periods (`Tf = 5*tau`). When you do not specify a time step, the function defaults to 64 samples per period (`Ts = tau/64`). Thus, this signal runs for 10 s with a time step of 0.03125 s. Plot the signal.

```
plot(t,u)
```

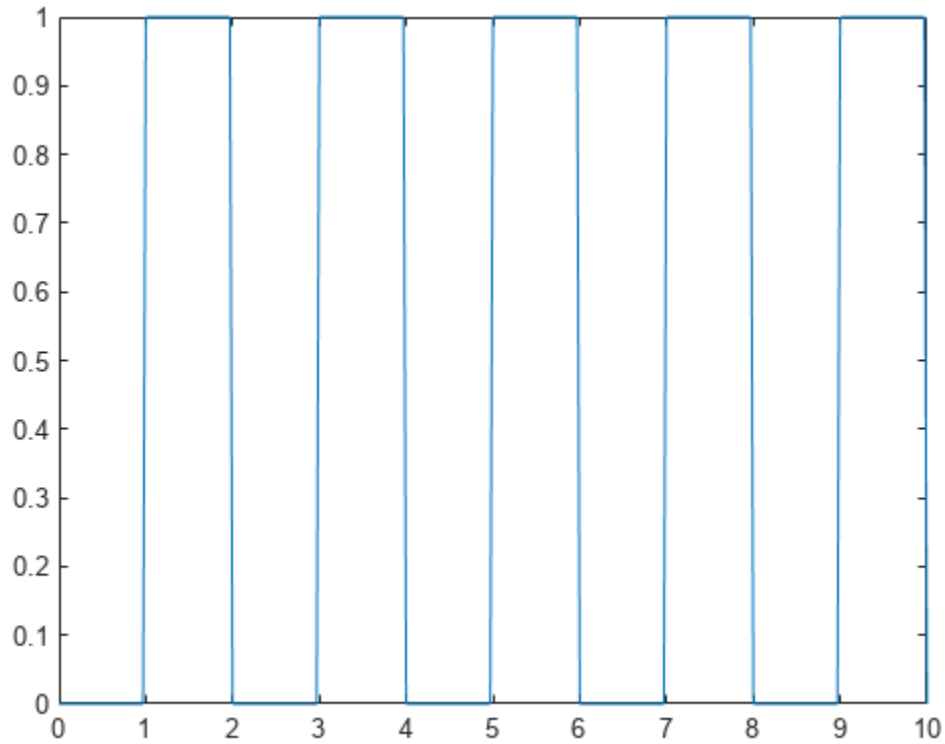

`gensig` returns a square wave of unit amplitude that starts at zero. You can modify `u` to obtain a square wave with a different amplitude and different endpoints. Create a square wave of period 5 that runs for 15 s, and that switches between values of -1 and 1.

```
tau = 5;  
Tf = 15;  
[u0,t] = gensig("square",tau,Tf);  
u = 2*u0-1;  
plot(t,u)
```

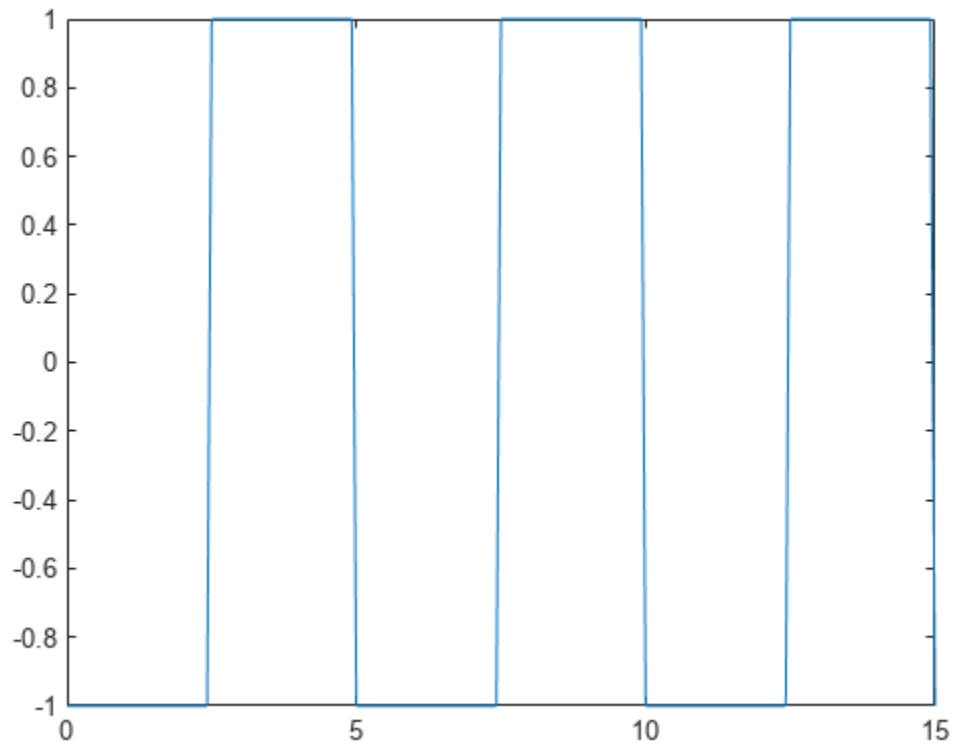
Use t and u to simulate the response of a dynamic system with `lsim`. The `lsim` command assumes the values of t are in the units of the dynamic system model that you simulate (`sys.TimeUnit`).

```
sys = tf(30,[1 5 30]);  
lsim(sys,u,t)
```

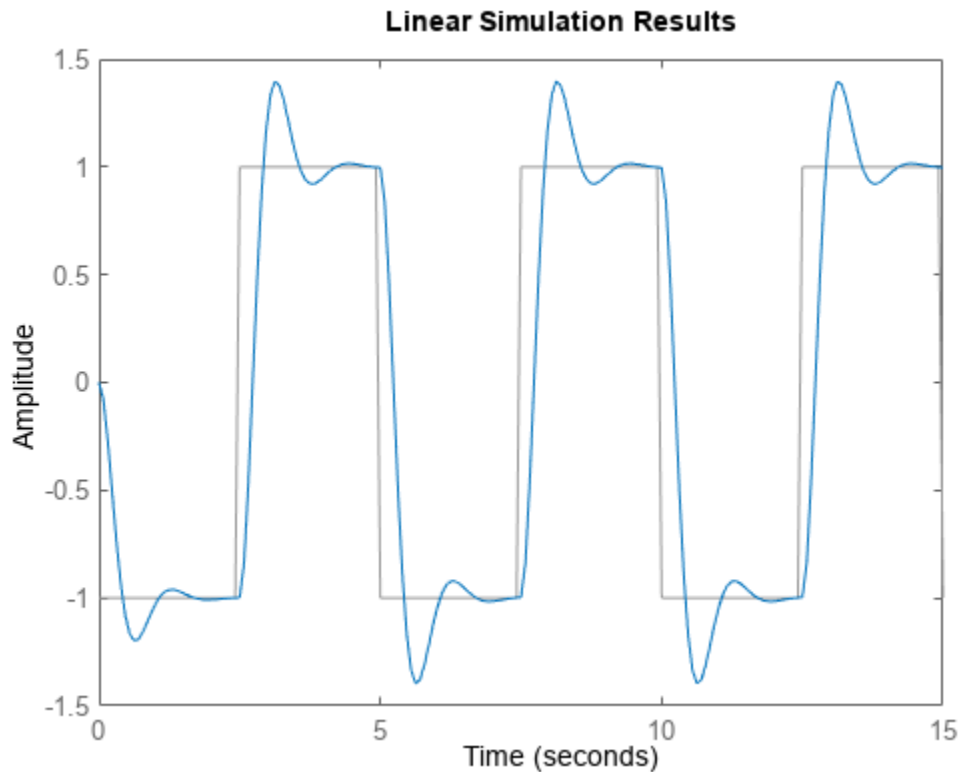

Generate Signal with Specified Sample Time

If you do not specify a time step (sample time), `gensig` defaults to 64 samples per period, or $T_s = \tau/64$. When you want to simulate a discrete-time model with `lsim`, the time step must equal the sample time of the model. Provide `gensig` with this sample time to generate a suitable signal. For example, generate a sine wave for simulating a discrete-time dynamic system model with a 0.1 s sample time.

```
tau = 3;  
Tf = 6;  
Ts = 0.1;  
[u,t] = gensig("sine",tau,Tf,Ts);
```

Simulate the model response to the generated signal.

```
sys = zpk([],[-0.1,-0.5],1,Ts);  
lsim(sys,u,t,Ts)
```

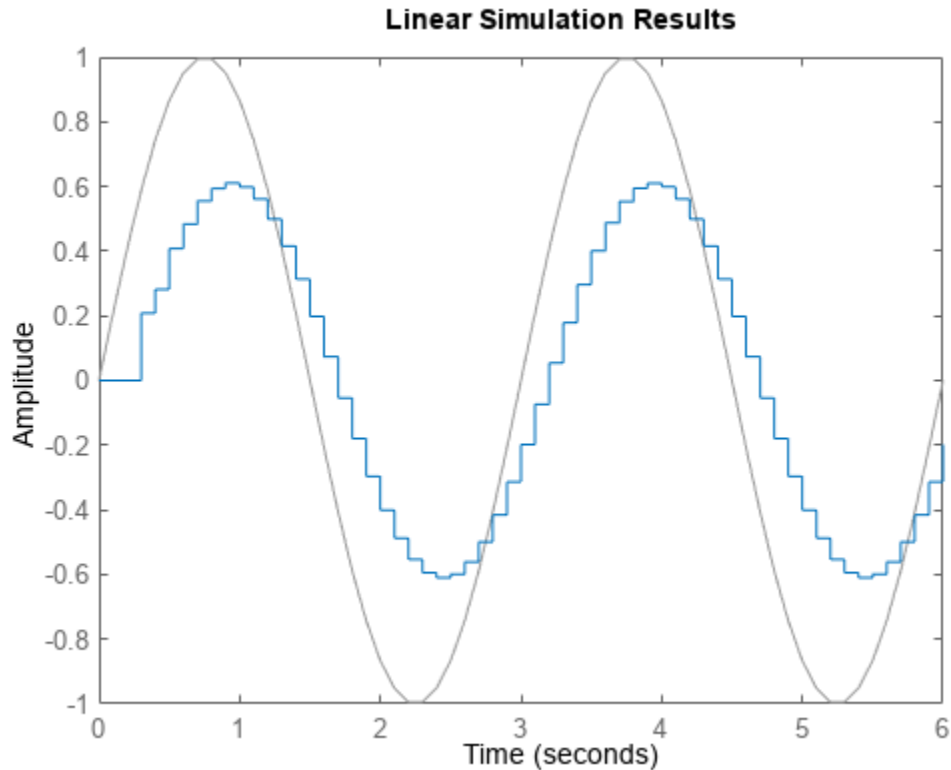

Generate Input for Simulating Multi-Input System

To simulate a multi-input system with `lsim`, you provide the input signals as a matrix whose columns represent the signal applied to each input. In other words, $u(:, j)$ is the signal applied to the j th input at each time step. To use `gensig` to generate such an input matrix, create the signals for each input together and stack them together in a matrix.

For instance, create a signal for simulating a two-input system that injects a square wave of period 2 s into the first input, and a pulse every 1.5 s into the second input. Specify a duration and sample time so that the two vectors have the same length, which is necessary for combining them into a matrix.

```
Tf = 8;
Ts = 0.02;
[uSq,t] = gensig("square",2,Tf,Ts);
[uPu,~] = gensig("pulse",1.5,Tf,Ts);
u = [uSq uPu];
size(u)
```

```
ans = 1x2
```

```
401    2
```

Each row $u(i, :)$ of u is the signal (u_1, u_2) applied to the inputs at the corresponding time $t(i)$.

You can combine signals that are not created with `gensig` provided they have the same length. For instance, suppose that you want to simulate a three-input system by applying `uSq` to the first input and `uPu` to second input. You also want to apply a ramp to the third input that starts at 0 and increases to 1 at the final time `Tf = 8`. Ensure that the signal is a column vector with the same length as `uSq` and `uPu`. Then combine it with the other signals to create the input matrix.

```
uRa = linspace(0,1,401)';  
u = [uSq uPu uRa];  
size(u)
```

```
ans = 1×2
```

```
401    3
```

```
plot(t,u)
```

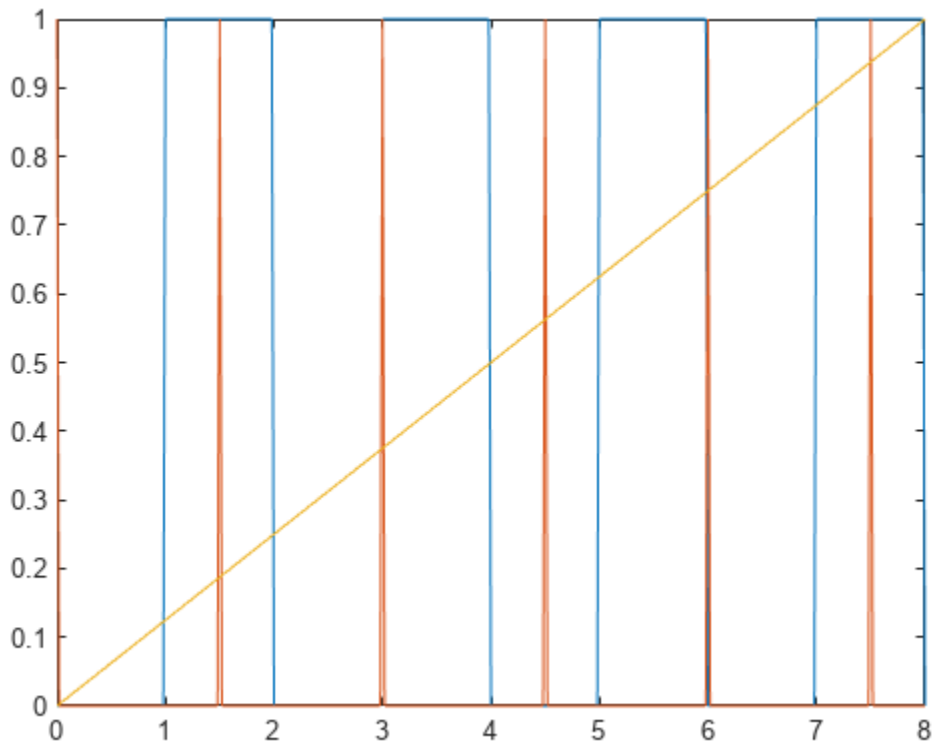

You can now use `u` and `t` to simulate a three-input model. Generate a three-input, two-output state-space model, and simulate the response at its two outputs to `u` applied at the inputs.

```
rng('default')  
sys = rss(3,2,3);  
lsim(sys,u,t)
```

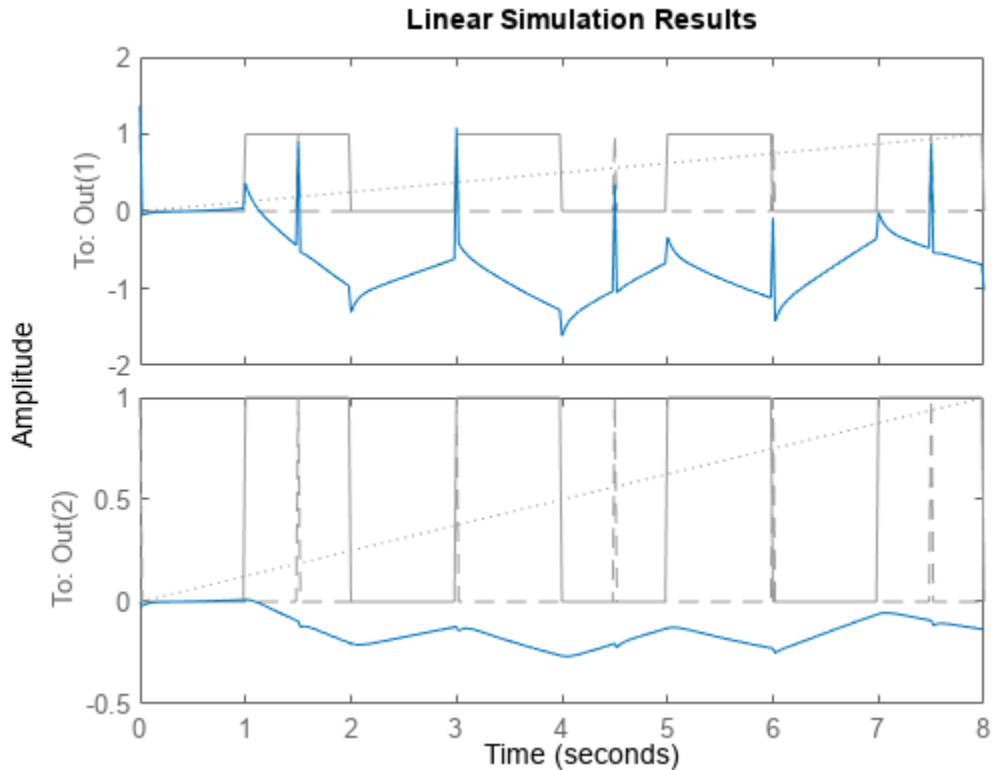

Input Arguments

type — Type of periodic signal

"sine" | "square" | "pulse"

Type of periodic signal to generate, specified as one of the following:

- "sine" — Sine wave
- "square" — Square wave
- "pulse" — Periodic pulse

All signals have unit amplitude and have the initial value 0 at $t = 0$. You can specify the type with a character vector instead of a string (for example, 'sine').

tau — Period

positive scalar

Period of generated signal, specified as a positive scalar value. Specify `tau` in the units of the dynamic system model you want to simulate with `lsim`. For instance, if `sys.TimeUnit` is 'seconds', then to generate a signal for simulating `sys` with a period of 30 s, set `tau` to 30. If `sys.TimeUnit` is 'minutes', then to generate such a signal, set `tau` to 0.5.

Tf — Duration

5*tau (default) | positive scalar

Duration of signal for simulation, specified as a positive scalar value. The output vector **t** is of the form $0:T_s:T_f$, where the time step is set by T_s . When you use **t** with `lsim` to simulate a dynamic system model, `lsim` interprets **t** as having the units specified in the `TimeUnit` property of the model.

Ts — Time step

`tau/64` (default) | positive scalar

Time step, specified as a positive scalar value. The output vector **t** is of the form $0:T_s:T_f$. The units of T_s are the units specified by the `TimeUnit` property dynamic system model you intend to simulate with `lsim`. When you are simulating a discrete-time model, set T_s equal to the sample time T_s of the model.

Output Arguments**u — Generated signal**

column vector

Generated signal, returned as a column vector of the same length as **t**. The shape of the signal is determined by `type`. The signal has unit amplitude with a baseline of 0.

t — Time vector

column vector

Time vector, returned as a column vector of the form $0:T_s:T_f$. If you do not specify a duration T_f , then `gensig` uses $T_f = 5*\tau$. If you do not specify a time step T_s , then `gensig` uses $\tau/64$.

Version History

Introduced before R2006a

See Also

`lsim` | `lsiminfo` | `lsimplot`

genss

Generalized state-space model

Description

Generalized state-space (**genss**) models are state-space models that include tunable parameters or components. **genss** models arise when you combine numeric LTI models with models containing tunable components (control design blocks). For more information about numeric LTI models and control design blocks, see “Models with Tunable Coefficients”.

You can use generalized state-space models to represent control systems having a mixture of fixed and tunable components. Use generalized state-space models for control design tasks such as parameter studies and parameter tuning with commands such as **systemtune** and **looptune**.

Construction

To construct a **genss** model:

- Use **series**, **parallel**, **lft**, or **connect**, or the arithmetic operators **+**, **-**, *****, **/**, ****, and **^**, to combine numeric LTI models with control design blocks.
- Use **tf** or **ss** with one or more input arguments that is a generalized matrix (**genmat**) instead of a numeric array
- Convert any numeric LTI model, control design block, or **sLTuner** interface (requires Simulink Control Design), for example, **sys**, to **genss** form using:

```
gensys = genss(sys)
```

When **sys** is an **sLTuner** interface, **gensys** contains all the tunable blocks and analysis points specified in this interface. To compute a tunable model of a particular I/O transfer function, call **getIOTransfer(gensys, in, out)**. Here, **in** and **out** are the analysis points of interest. (Use **getPoints(sys)** to get the full list of analysis points.) Similarly, to compute a tunable model of a particular open-loop transfer function, use **getLoopTransfer(gensys, loc)**. Here, **loc** is the analysis point of interest.

Properties

Blocks

Structure containing the control design blocks included in the generalized LTI model or generalized matrix. The field names of **Blocks** are the **Name** property of each control design block.

You can change some attributes of these control design blocks using dot notation. For example, if the generalized LTI model or generalized matrix **M** contains a **realp** tunable parameter **a**, you can change the current value of **a** using:

```
M.Blocks.a.Value = -1;
```

A, B, C, D

Dependency of state-space matrices on tunable and uncertain parameters, stored as a generalized matrix (`genmat`), uncertain matrix (`umat`), or double array.

These properties model the dependency of the state-space matrices on static control design blocks, `realp`, `ureal`, `ucomplex`, or `ucomplexm`. Dynamic control design blocks such as `tunableGain` or `tunableSS` set to their current values, and internal delays are set to zero.

When the corresponding state-space matrix does not depend on any static control design blocks, these properties evaluate to double matrices.

For an example, see “Dependence of State-Space Matrices on Parameters” on page 2-367.

E

E matrix, stored as a double matrix when the generalized state-space equations are implicit. The value `E = []` means that the generalized state-space equations are explicit. For more information about implicit state-space models, see “State-Space Models”.

StateName

State names, stored as one of the following:

- Character vector — For first-order models, for example, `'velocity'`.
- Cell array of character vectors — For models with two or more states, for example, `{'position'; 'velocity'}`.
- `''` — For unnamed states.

You can assign state names to a `genss` model only when all its control design blocks are static. Otherwise, specify the state names for the component models before interconnecting them to create the `genss` model. When you do so, the `genss` model tracks the assigned state names. For an example, see “Track State Names in Generalized State-Space Model” on page 2-366.

Default: `''` for all states

StateUnit

State unit labels, stored as one of the following:

- Character vector — For first-order models, for example, `'m/s'`.
- Cell array of character vectors — For models with two or more states, for example, `{'m'; 'm/s'}`.
- `''` — For unnamed states.

`StateUnit` labels the units of each state for convenience, and has no effect on system behavior.

You can assign state units to a `genss` model only when all its control design blocks are static. Otherwise, specify the state units for the component models before interconnecting them to create the `genss` model. When you do so, the `genss` model tracks the assigned state units. For an example, see “Track State Names in Generalized State-Space Model” on page 2-366.

Default: `''` for all states

InternalDelay

Vector storing internal delays.

Internal delays arise, for example, when closing feedback loops on systems with delays, or when connecting delayed systems in series or parallel. For more information about internal delays, see “Closing Feedback Loops with Time Delays”.

For continuous-time models, internal delays are expressed in the time unit specified by the `TimeUnit` property of the model. For discrete-time models, internal delays are expressed as integer multiples of the sample time T_s . For example, `InternalDelay = 3` means a delay of three sampling periods.

You can modify the values of internal delays. However, the number of entries in `sys.InternalDelay` cannot change, because it is a structural property of the model.

InputDelay

Input delay for each input channel, specified as a scalar value or numeric vector. For continuous-time systems, specify input delays in the time unit stored in the `TimeUnit` property. For discrete-time systems, specify input delays in integer multiples of the sample time T_s . For example, `InputDelay = 3` means a delay of three sample times.

For a system with N_u inputs, set `InputDelay` to an N_u -by-1 vector. Each entry of this vector is a numerical value that represents the input delay for the corresponding input channel.

You can also set `InputDelay` to a scalar value to apply the same delay to all channels.

Default: 0

OutputDelay

Output delays. `OutputDelay` is a numeric vector specifying a time delay for each output channel. For continuous-time systems, specify output delays in the time unit stored in the `TimeUnit` property. For discrete-time systems, specify output delays in integer multiples of the sample time T_s . For example, `OutputDelay = 3` means a delay of three sampling periods.

For a system with N_y outputs, set `OutputDelay` to an N_y -by-1 vector, where each entry is a numerical value representing the output delay for the corresponding output channel. You can also set `OutputDelay` to a scalar value to apply the same delay to all channels.

Default: 0 for all output channels

T_s

Sample time. For continuous-time models, $T_s = 0$. For discrete-time models, T_s is a positive scalar representing the sampling period. This value is expressed in the unit specified by the `TimeUnit` property of the model. To denote a discrete-time model with unspecified sample time, set $T_s = -1$.

Changing this property does not discretize or resample the model.

Default: 0 (continuous time)

TimeUnit

Units for the time variable, the sample time T_s , and any time delays in the model, specified as one of the following values:

- 'nanoseconds'
- 'microseconds'
- 'milliseconds'
- 'seconds'
- 'minutes'
- 'hours'
- 'days'
- 'weeks'
- 'months'
- 'years'

Changing this property has no effect on other properties, and therefore changes the overall system behavior. Use `chgTimeUnit` to convert between time units without modifying system behavior.

Default: 'seconds'

InputName

Input channel names, specified as one of the following:

- Character vector — For single-input models, for example, 'controls'.
- Cell array of character vectors — For multi-input models.

Alternatively, use automatic vector expansion to assign input names for multi-input models. For example, if `sys` is a two-input model, enter:

```
sys.InputName = 'controls';
```

The input names automatically expand to {'controls(1)'; 'controls(2)'}

You can use the shorthand notation `u` to refer to the `InputName` property. For example, `sys.u` is equivalent to `sys.InputName`.

Input channel names have several uses, including:

- Identifying channels on model display and plots
- Extracting subsystems of MIMO systems
- Specifying connection points when interconnecting models

Default: '' for all input channels

InputUnit

Input channel units, specified as one of the following:

- Character vector — For single-input models, for example, 'seconds'.
- Cell array of character vectors — For multi-input models.

Use `InputUnit` to keep track of input signal units. `InputUnit` has no effect on system behavior.

Default: '' for all input channels

InputGroup

Input channel groups. The `InputGroup` property lets you assign the input channels of MIMO systems into groups and refer to each group by name. Specify input groups as a structure. In this structure, field names are the group names, and field values are the input channels belonging to each group. For example:

```
sys.InputGroup.controls = [1 2];
sys.InputGroup.noise = [3 5];
```

creates input groups named `controls` and `noise` that include input channels 1, 2 and 3, 5, respectively. You can then extract the subsystem from the `controls` inputs to all outputs using:

```
sys(:, 'controls')
```

Default: Struct with no fields

OutputName

Output channel names, specified as one of the following:

- Character vector — For single-output models. For example, `'measurements'`.
- Cell array of character vectors — For multi-output models.

Alternatively, use automatic vector expansion to assign output names for multi-output models. For example, if `sys` is a two-output model, enter:

```
sys.OutputName = 'measurements';
```

The output names automatically expand to `{'measurements(1)'; 'measurements(2)'}`.

You can use the shorthand notation `y` to refer to the `OutputName` property. For example, `sys.y` is equivalent to `sys.OutputName`.

Output channel names have several uses, including:

- Identifying channels on model display and plots
- Extracting subsystems of MIMO systems
- Specifying connection points when interconnecting models

Default: `''` for all output channels

OutputUnit

Output channel units, specified as one of the following:

- Character vector — For single-output models. For example, `'seconds'`.
- Cell array of character vectors — For multi-output models.

Use `OutputUnit` to keep track of output signal units. `OutputUnit` has no effect on system behavior.

Default: `''` for all output channels

OutputGroup

Output channel groups. The `OutputGroup` property lets you assign the output channels of MIMO systems into groups and refer to each group by name. Specify output groups as a structure. In this

structure, field names are the group names, and field values are the output channels belonging to each group. For example:

```
sys.OutputGroup.temperature = [1];  
sys.InputGroup.measurement = [3 5];
```

creates output groups named `temperature` and `measurement` that include output channels 1, and 3, 5, respectively. You can then extract the subsystem from all inputs to the measurement outputs using:

```
sys('measurement', :)
```

Default: Struct with no fields

Name

System name, specified as a character vector. For example, `'system_1'`.

Default: `''`

Notes

Any text that you want to associate with the system, stored as a string or a cell array of character vectors. The property stores whichever data type you provide. For instance, if `sys1` and `sys2` are dynamic system models, you can set their `Notes` properties as follows:

```
sys1.Notes = "sys1 has a string."  
sys2.Notes = 'sys2 has a character vector.'  
sys1.Notes  
sys2.Notes
```

```
ans =
```

```
    "sys1 has a string."
```

```
ans =
```

```
    'sys2 has a character vector.'
```

Default: `[0×1 string]`

UserData

Any type of data you want to associate with system, specified as any MATLAB data type.

Default: `[]`

SamplingGrid

Sampling grid for model arrays, specified as a data structure.

For model arrays that are derived by sampling one or more independent variables, this property tracks the variable values associated with each model in the array. This information appears when you display or plot the model array. Use this information to trace results back to the independent variables.

Set the field names of the data structure to the names of the sampling variables. Set the field values to the sampled variable values associated with each model in the array. All sampling variables should be numeric and scalar valued, and all arrays of sampled values should match the dimensions of the model array.

For example, suppose you create a 11-by-1 array of linear models, `sysarr`, by taking snapshots of a linear time-varying system at times `t = 0:10`. The following code stores the time samples with the linear models.

```
sysarr.SamplingGrid = struct('time',0:10)
```

Similarly, suppose you create a 6-by-9 model array, `M`, by independently sampling two variables, `zeta` and `w`. The following code attaches the (`zeta,w`) values to `M`.

```
[zeta,w] = ndgrid(<6 values of zeta>,<9 values of w>)
M.SamplingGrid = struct('zeta',zeta,'w',w)
```

When you display `M`, each entry in the array includes the corresponding `zeta` and `w` values.

`M`

```
M(:,:,1,1) [zeta=0.3, w=5] =
```

```
      25
-----
s^2 + 3 s + 25
```

```
M(:,:,2,1) [zeta=0.35, w=5] =
```

```
      25
-----
s^2 + 3.5 s + 25
```

...

For model arrays generated by linearizing a Simulink model at multiple parameter values or operating points, the software populates `SamplingGrid` automatically with the variable values that correspond to each entry in the array. For example, the Simulink Control Design commands `linearize` and `sLinearizer` populate `SamplingGrid` in this way.

Default: []

Examples

Tunable Low-Pass Filter

In this example, you will create a low-pass filter with one tunable parameter a :

$$F = \frac{a}{s + a}$$

Since the numerator and denominator coefficients of a `tunableTF` block are independent, you cannot use `tunableTF` to represent F . Instead, construct F using the tunable real parameter object `realp`.

Create a real tunable parameter with an initial value of 10.

```
a = realp('a',10)
```

```
a =
    Name: 'a'
    Value: 10
    Minimum: -Inf
    Maximum: Inf
    Free: 1
```

Real scalar parameter.

Use `tf` to create the tunable low-pass filter `F`.

```
numerator = a;
denominator = [1,a];
F = tf(numerator,denominator)
```

```
F =
```

```
Generalized continuous-time state-space model with 1 outputs, 1 inputs, 1 states, and the following parameters:
a: Scalar parameter, 2 occurrences.
```

Type `"ss(F)"` to see the current value, `"get(F)"` to see all properties, and `"F.Blocks"` to interact with the blocks.

`F` is a `genss` object which has the tunable parameter `a` in its `Blocks` property. You can connect `F` with other tunable or numeric models to create more complex control system models. For an example, see “Control System with Tunable Components”.

Create State-Space Model with Both Fixed and Tunable Parameters

This example shows how to create a state-space `genss` model having both fixed and tunable parameters.

$$A = \begin{bmatrix} 1 & a+b \\ 0 & ab \end{bmatrix}, \quad B = \begin{bmatrix} -3.0 \\ 1.5 \end{bmatrix}, \quad C = [0.3 \ 0], \quad D = 0,$$

where a and b are tunable parameters, whose initial values are -1 and 3 , respectively.

Create the tunable parameters using `realp`.

```
a = realp('a',-1);
b = realp('b',3);
```

Define a generalized matrix using algebraic expressions of a and b .

```
A = [1 a+b;0 a*b];
```

`A` is a generalized matrix whose `Blocks` property contains a and b . The initial value of `A` is `[1 2;0 -3]`, from the initial values of a and b .

Create the fixed-value state-space matrices.

```
B = [-3.0;1.5];
C = [0.3 0];
D = 0;
```

Use `ss` to create the state-space model.

```
sys = ss(A,B,C,D)
```

```
sys =
```

```
Generalized continuous-time state-space model with 1 outputs, 1 inputs, 2 states, and the following parameters:
  a: Scalar parameter, 2 occurrences.
  b: Scalar parameter, 2 occurrences.
```

Type `"ss(sys)"` to see the current value, `"get(sys)"` to see all properties, and `"sys.Blocks"` to inspect the blocks.

`sys` is a generalized LTI model (`genss`) with tunable parameters `a` and `b`.

Control System Model with Both Numeric and Tunable Components

This example shows how to create a tunable model of a control system that has both fixed plant and sensor dynamics and tunable control components.

Consider the control system of the following illustration.

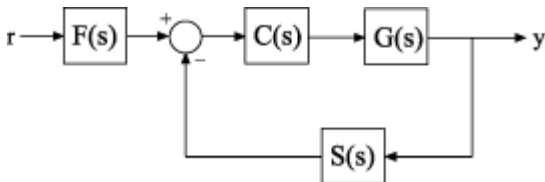

Suppose that the plant response is $G(s) = 1/(s + 1)^2$, and that the model of the sensor dynamics is $S(s) = 5/(s + 4)$. The controller C is a tunable PID controller, and the prefilter $F = a/(s + a)$ is a low-pass filter with one tunable parameter, a .

Create models representing the plant and sensor dynamics. Because the plant and sensor dynamics are fixed, represent them using numeric LTI models.

```
G = zpk([], [-1, -1], 1);
S = tf(5, [1 4]);
```

To model the tunable components, use Control Design Blocks. Create a tunable representation of the controller C .

```
C = tunablePID('C', 'PID');
```

`C` is a `tunablePID` object, which is a Control Design Block with a predefined proportional-integral-derivative (PID) structure.

Create a model of the filter $F = a/(s + a)$ with one tunable parameter.

```
a = realp('a', 10);
F = tf(a, [1 a]);
```

`a` is a `realp` (real tunable parameter) object with initial value 10. Using `a` as a coefficient in `tf` creates the tunable `genss` model object `F`.

Interconnect the models to construct a model of the complete closed-loop response from r to y .

```
T = feedback(G*C,S)*F
```

```
T =
```

```
Generalized continuous-time state-space model with 1 outputs, 1 inputs, 5 states, and the following tunable elements:
  C: Tunable PID controller, 1 occurrences.
  a: Scalar parameter, 2 occurrences.
```

Type "ss(T)" to see the current value, "get(T)" to see all properties, and "T.Blocks" to interact with the tunable elements.

T is a `genss` model object. In contrast to an aggregate model formed by connecting only numeric LTI models, T keeps track of the tunable elements of the control system. The tunable elements are stored in the `Blocks` property of the `genss` model object. Examine the tunable elements of T.

```
T.Blocks
```

```
ans = struct with fields:
  C: [1x1 tunablePID]
  a: [1x1 realp]
```

When you create a `genss` model of a control system that has tunable components, you can use tuning commands such as `systune` to tune the free parameters to meet design requirements you specify.

Track State Names in Generalized State-Space Model

Create a `genss` model with labeled state names. To do so, label the states of the component LTI models before connecting them. For instance, connect a two-state fixed-coefficient plant model and a one-state tunable controller.

```
A = [-1 -1; 1 0];
B = [1; 0];
C = [0 1];
D = 0;
G = ss(A,B,C,D);
G.StateName = {'Pstate1', 'Pstate2'};
```

```
C = tunableSS('C',1,1,1);
```

```
L = G*C;
```

The `genss` model L preserves the state names of the components that created it. Because you did not assign state names to the tunable component C, the software automatically does so. Examine the state names of L to confirm them.

```
L.StateName
```

```
ans = 3x1 cell
    {'Pstate1'}
    {'Pstate2'}
    {'C.x1' }
```

The automatic assignment of state names to control design blocks allows you to trace which states in the generalized model are contributed by tunable components.

State names are also preserved when you convert a genss model to a fixed-coefficient state-space model. To confirm, convert L to ss form.

```
Lfixed = ss(L);
Lfixed.StateName

ans = 3x1 cell
    {'Pstate1'}
    {'Pstate2'}
    {'C.x1' }
```

State unit labels, stored in the StateUnit property of the genss model, behave similarly.

Dependence of State-Space Matrices on Parameters

Create a generalized model with a tunable parameter, and examine the dependence of the A matrix on that parameter. To do so, examine the A property of the generalized model.

```
G = tf(1,[1 10]);
k = realp('k',1);
F = tf(k,[1 k]);
L1 = G*F;
L1.A
```

```
ans =
```

```
Generalized matrix with 2 rows, 2 columns, and the following blocks:
    k: Scalar parameter, 2 occurrences.
```

Type "double(ans)" to see the current value, "get(ans)" to see all properties, and "ans.Blocks" to see the blocks.

The A property is a generalized matrix that preserves the dependence on the real tunable parameter k. The state-space matrix properties A, B, C, and D only preserve dependencies on static parameters. When the genss model has dynamic control design blocks, these are set to their current value for evaluating the state-space matrix properties. For example, examine the A matrix property of a genss model with a tunable PI block.

```
C = tunablePID('C','PI');
L2 = G*C;
L2.A
```

```
ans = 2x2
```

```
   -10.0000    0.0010
         0         0
```

Here, the A matrix is stored as a double matrix, whose value is the A matrix of the current value of L2.

```
L2cur = ss(L2);
L2cur.A
```

```
ans = 2x2
```

```
-10.0000    0.0010  
      0      0
```

Additionally, extracting state-space matrices using `ssdata` sets all control design blocks to their current or nominal values, including static blocks. Thus, the following operations all return the current value of the A matrix of L1.

```
[A,B,C,D] = ssdata(L1);  
A
```

```
A = 2×2
```

```
-10    1  
      0   -1
```

```
double(L1.A)
```

```
ans = 2×2
```

```
-10    1  
      0   -1
```

```
L1cur = ss(L1);  
L1cur.A
```

```
ans = 2×2
```

```
-10    1  
      0   -1
```

Tips

- You can manipulate `genss` models as ordinary `ss` models. Analysis commands such as `bode` and `step` evaluate the model by replacing each tunable parameter with its current value.

Version History

Introduced in R2011a

See Also

`realp` | `genmat` | `genfrd` | `tf` | `ss` | `getValue` | `tunablePID` | `feedback` | `connect`

Topics

“Models with Tunable Coefficients”

“Dynamic System Models”

“Control Design Blocks”

get

Access model property values

Syntax

```
Value = get(sys, 'PropertyName')
Struct = get(sys)
```

Description

`Value = get(sys, 'PropertyName')` returns the current value of the property `PropertyName` of the model object `sys`. `'PropertyName'` can be the full property name (for example, `'UserData'`) or any unambiguous case-insensitive abbreviation (for example, `'user'`). See reference pages for the individual model object types for a list of properties available for that model.

`Struct = get(sys)` converts the TF, SS, or ZPK object `sys` into a standard MATLAB structure with the property names as field names and the property values as field values.

Without left-side argument,

```
get(sys)
```

displays all properties of `sys` and their values.

Examples

Display Model Property Values

Create the following discrete-time SISO transfer function model:

$$H(z) = \frac{1}{z+2}$$

Specify the sample time as 0.1 seconds and input channel name as `Voltage`.

```
h = tf(1, [1 2], 0.1, 'InputName', 'Voltage')
```

```
h =
```

```
From input "Voltage" to output:
```

```
  1
  ----
 z + 2
```

```
Sample time: 0.1 seconds
Discrete-time transfer function.
```

Display all the properties of the transfer function.

```
get(h)
```

```
    Numerator: {[0 1]}
  Denominator: {[1 2]}
    Variable: 'z'
    IODelay: 0
  InputDelay: 0
OutputDelay: 0
  InputName: {'Voltage'}
  InputUnit: {''}
  InputGroup: [1x1 struct]
  OutputName: {''}
  OutputUnit: {''}
  OutputGroup: [1x1 struct]
    Notes: [0x1 string]
  UserData: []
    Name: ''
    Ts: 0.1000
  TimeUnit: 'seconds'
SamplingGrid: [1x1 struct]
```

Display the numerator of the transfer function.

```
num = get(h, 'Numerator')

num = 1x1 cell array
    {[0 1]}
```

The numerator data is stored as a cell array, thus the `Numerator` property is a cell array containing the row vector `[0 1]`.

```
num{1}

ans = 1x2

    0    1
```

Display the sample time `Ts` of the transfer function.

```
get(h, 'Ts')

ans = 0.1000
```

Alternatively, use dot notation to access the property value.

```
h.Ts

ans = 0.1000
```

Tips

An alternative to the syntax

```
Value = get(sys, 'PropertyName')
```

is the structure-like referencing

```
Value = sys.PropertyName
```

For example,

```
sys.Ts  
sys.A  
sys.user
```

return the values of the sample time, *A* matrix, and `UserData` property of the (state-space) model `sys`.

Version History

Introduced before R2006a

See Also

[frdata](#) | [set](#) | [ssdata](#) | [tfdata](#) | [zpkdata](#) | [idssdata](#) | [polydata](#)

getBlockValue

Current value of Control Design Block in Generalized Model

Syntax

```
val = getBlockValue(M,blockname)
[val1,val2,...] = getBlockValue(M,blockname1,blockname2,...)
S = getBlockValue(M)
```

Description

`val = getBlockValue(M,blockname)` returns the current value of the Control Design Block `blockname` in the Generalized Model `M`. (For uncertain blocks, the “current value” is the nominal value of the block.)

`[val1,val2,...] = getBlockValue(M,blockname1,blockname2,...)` returns the values of the specified Control Design Blocks.

`S = getBlockValue(M)` returns the values of all Control Design Blocks of the generalized model in a structure. This syntax lets you transfer the block values from one generalized model to another model that uses the same Control Design Blocks, as follows:

```
S = getBlockValue(M1);
setBlockValue(M2,S);
```

Input Arguments

M

Generalized LTI (gens) model or generalized matrix (genmat).

blockname

Name of the Control Design Block in the model `M` whose current value is evaluated.

To get a list of the Control Design Blocks in `M`, enter `M.Blocks`.

Output Arguments

val

Numerical LTI model or numerical value, equal to the current value of the Control Design Block `blockname`.

S

Current values of all Control Design Blocks in `M`, returned as a structure. The names of the fields in `S` are the names of the blocks in `M`. The values of the fields are numerical LTI models or numerical values equal to the current values of the corresponding Control Design Blocks.

Examples

Get Current Values of Single Blocks

Create a tunable `genss` model, and evaluate the current value of the Control Design Blocks of the model.

Typically, you use `getBlockValue` to retrieve the tuned values of control design blocks after tuning the `genss` model using a tuning command such as `systemtune`. For this example, create the model and retrieve the initial block values.

```
G = zpk([], [-1, -1], 1);
C = tunablePID('C', 'PID');
a = realp('a', 10);
F = tf(a, [1 a]);
T = feedback(G*C, 1)*F;
```

```
Cval = getBlockValue(T, 'C')
```

Continuous-time I-only controller:

$$K_i * \frac{1}{s}$$

With $K_i = 0.001$

`Cval` is a numeric pid controller object.

```
aval = getBlockValue(T, 'a')
```

```
aval =
    10
```

`aval` is a numeric scalar, because `a` is a real scalar parameter.

Get All Current Values as Structure

Using the `genss` model of the previous example, get the current values of all blocks in the model.

```
G = zpk([], [-1, -1], 1);
C = tunablePID('C', 'PID');
a = realp('a', 10);
F = tf(a, [1 a]);
T = feedback(G*C, 1)*F;
```

```
S = getBlockValue(T)
```

```
S =
```

```
    C: [1x1 pid]
    a: 10
```

Version History

Introduced in R2011b

See Also

setBlockValue | showBlockValue | getValue

Topics

Generalized Model

Control Design Block

getCompSensitivity

Complementary sensitivity function from generalized model of control system

Syntax

```
T = getCompSensitivity(CL,location)
T = getCompSensitivity(CL,location,opening)
```

Description

`T = getCompSensitivity(CL,location)` returns the complementary sensitivity on page 2-378 measured at the specified location for a generalized model of a control system.

`T = getCompSensitivity(CL,location,opening)` specifies additional loop openings for the complementary sensitivity function calculation. Use an opening, for example, to calculate the complementary sensitivity function of an inner loop, with the outer loop open.

If `opening` and `location` list the same point, the software opens the loop after adding the disturbance signal at the point.

Examples

Complementary Sensitivity Function at a Location

Compute the complementary sensitivity at the plant output, X , of the control system of the following illustration.

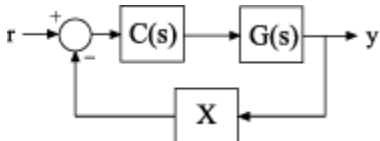

Create a model of the system by specifying and connecting a numeric LTI plant model G , a tunable controller C , and the `AnalysisPoint` block X . Use the `AnalysisPoint` block to mark the location where you assess the complementary sensitivity, which in this example is the plant output.

```
G = tf([1],[1 5]);
C = tunablePID('C','p');
C.Kp.Value = 3;
X = AnalysisPoint('X');
CL = feedback(G*C,X);
```

`CL` is a `genss` model that represents the closed-loop response of the control system from r to y . Examine the Control Design Blocks of the model.

`CL.Blocks`

```
ans = struct with fields:
    C: [1x1 tunablePID]
```

```
X: [1x1 AnalysisPoint]
```

The model's blocks include the `AnalysisPoint` block, `X`, that identifies the analysis-point location.

Calculate the complementary sensitivity, T , at `X`.

```
T = getCompSensitivity(CL, 'X')
```

```
T =
```

```
Generalized continuous-time state-space model with 1 outputs, 1 inputs, 1 states, and the following blocks:
```

```
C: Tunable PID controller, 1 occurrences.
```

```
X: Analysis point, 1 channels, 1 occurrences.
```

Type `"ss(T)"` to see the current value, `"get(T)"` to see all properties, and `"T.Blocks"` to interact with the blocks.

`getCompSensitivity` preserves the Control Design Blocks of `CL`, and returns a `genss` model. To get a numeric model, you can convert `T` to transfer-function form, using the current value of the tunable block.

```
Tnum = tf(T)
```

```
Tnum =
```

```
From input "X" to output "X":
```

```
  -3
  ----
  s + 8
```

Continuous-time transfer function.

Specify Additional Loop Opening for Complementary Sensitivity Function Calculation

In the multiloop system of the following illustration, calculate the inner-loop sensitivity at the output of `G2`, with the outer loop open.

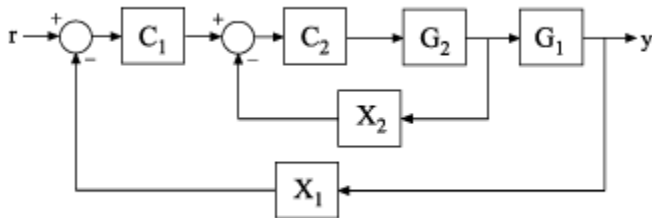

Create a model of the system by specifying and connecting the numeric plant models, tunable controllers, and `AnalysisPoint` blocks. `G1` and `G2` are plant models, `C1` and `C2` are tunable controllers, and `X1` and `X2` are `AnalysisPoint` blocks that mark potential loop-opening locations.

```
G1 = tf(10,[1 10]);
G2 = tf([1 2],[1 0.2 10]);
C1 = tunablePID('C','pi');
```

```
C2 = tunableGain('G',1);
X1 = AnalysisPoint('X1');
X2 = AnalysisPoint('X2');
CL = feedback(G1*feedback(G2*C2,X2)*C1,X1);
```

Calculate the complementary sensitivity, T , at X2, with the outer loop open at X1. Specifying X1 as the third input argument tells `getCompSensitivity` to open the loop at that location.

```
T = getCompSensitivity(CL, 'X2', 'X1');
tf(T)
```

```
ans =
```

```
From input "X2" to output "X2":
      -s - 2
-----
s^2 + 1.2 s + 12
```

Continuous-time transfer function.

Input Arguments

CL — Model of control system

generalized state-space model

Model of a control system, specified as a generalized state-space model (`genss`).

Locations at which you can perform sensitivity analysis or open loops are marked by `AnalysisPoint` blocks in CL. Use `getPoints(CL)` to get the list of such locations.

location — Location

character vector | cell array of character vectors

Location at which you calculate the complementary sensitivity function on page 2-378, specified as a character vector or cell array of character vectors. To extract the complementary sensitivity function at multiple locations, use a cell array of character vectors.

Each specified location must match an analysis point in CL. Analysis points are marked using `AnalysisPoint` blocks. To get the list of available analysis points in CL, use `getPoints(CL)`.

Example: 'u' or {'u','y'}

opening — Additional loop opening

character vector | cell array of character vectors

Additional loop opening used to calculate the complementary sensitivity function on page 2-378, specified as a character vector or cell array of character vectors. To open the loop at multiple locations, use a cell array of character vectors.

Each specified opening must match an analysis point in CL. Analysis points are marked using `AnalysisPoint` blocks. To get the list of available analysis points in CL, use `getPoints(CL)`.

Use an opening, for example, to calculate the complementary sensitivity function of an inner loop, with the outer loop open.

If `opening` and `location` list the same point, the software opens the loop after adding the disturbance signal at the point.

Example: `'y_outer'` or `{'y_outer', 'y_outer2'}`

Output Arguments

T – Complementary sensitivity function

generalized state-space model

Complementary sensitivity function on page 2-378 of the control system, T , measured at `location`, returned as a generalized state-space model (`genss`).

- If `location` specifies a single analysis point, then T is a SISO `genss` model.
- If `location` is a vector signal, or specifies multiple analysis points, then T is a MIMO `genss` model.

More About

Complementary Sensitivity

The complementary sensitivity function, T , at a point is the closed-loop transfer function around the feedback loop measured at the specified location. It is related to the open-loop transfer function, L , and the sensitivity function, S , at the same point as follows:

$$T = \frac{L}{1-L} = S - 1.$$

Use `getLoopTransfer` and `getSensitivity` to compute L and S .

Consider the following model:

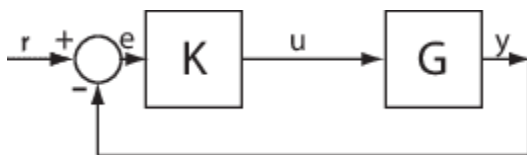

The complementary sensitivity, T , at y is defined as the transfer function from dy to y .

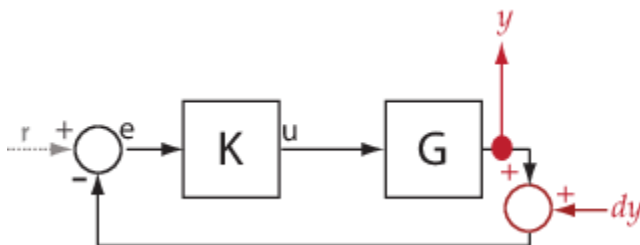

Observe that, in contrast to the sensitivity function, the disturbance, dy , is added *after* the measurement, y .

$$\begin{aligned}
 y &= -GK(y + dy) \\
 \rightarrow y &= -GKy - GKdy \\
 \rightarrow (I + GK)y &= -GKdy \\
 \rightarrow y &= \square_T (I + GK)^{-1} GKdy.
 \end{aligned}$$

Here, I is an identity matrix of the same size as GK . The complementary sensitivity transfer function at y is equal to -1 times the closed-loop transfer function from r to y .

Complementary sensitivity at multiple locations, for example, u and y , is defined as the MIMO transfer function from the disturbances to measurements:

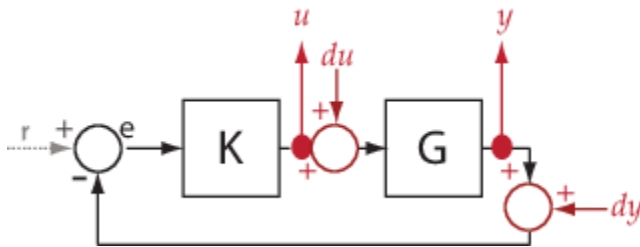

$$T = \begin{bmatrix} T_{du \rightarrow u} & T_{dy \rightarrow u} \\ T_{du \rightarrow y} & T_{dy \rightarrow y} \end{bmatrix}.$$

Version History

Introduced in R2014a

See Also

getPoints | AnalysisPoint | genss | getLoopTransfer | systune | getIOTransfer | getSensitivity | getValue | getCompSensitivity

getComponents

Extract SISO control components from a 2-DOF PID controller

Syntax

```
[C,X] = getComponents(C2,looptype)
```

Description

`[C,X] = getComponents(C2,looptype)` decomposes the 2-DOF PID controller `C2` into two SISO control components. One of the control components, `C`, is a 1-DOF PID controller. The other, `X`, is a SISO dynamic system. When `C` and `X` are connected in the loop structure specified by `looptype`, the resulting closed-loop system is equivalent to the 2-DOF control loop.

For more information about 2-DOF PID control architectures, see “Two-Degree-of-Freedom PID Controllers”.

Examples

Extract SISO Components from 2-DOF PID Controller

Decompose a 2-DOF PID controller into SISO control components, using each of the feedforward, feedback, and filter configurations.

To start, obtain a 2-DOF PID controller. For this example, create a plant model and tune a 2-DOF PID controller for it.

```
G = tf(1,[1 0.5 0.1]);
C2 = pidtune(G,'pidf2',1.5)
```

```
C2 =
```

$$u = K_p (b*r-y) + K_i \frac{1}{s} (r-y) + K_d \frac{s}{T_f*s+1} (c*r-y)$$

with $K_p = 1.12$, $K_i = 0.23$, $K_d = 1.3$, $T_f = 0.122$, $b = 0.664$, $c = 0.0136$

Continuous-time 2-DOF PIDF controller in parallel form.

`C2` is a `pid2` controller object, with two inputs and one output. Decompose `C2` into SISO control components using the feedforward configuration.

```
[Cff,Xff] = getComponents(C2,'feedforward')
```

```
Cff =
```

$$K_p + K_i * \frac{1}{s} + K_d * \frac{s}{T_f*s+1}$$

with $K_p = 1.12$, $K_i = 0.23$, $K_d = 1.3$, $T_f = 0.122$

Continuous-time PIDF controller in parallel form.

Xff =

$$\frac{-10.898 (s+0.2838)}{(s+8.181)}$$

Continuous-time zero/pole/gain model.

As the display shows, this command returns the SISO PID controller Cff as a pid object. The feedforward compensator X is returned as a zpk object.

Decompose C2 using the feedback configuration. In this case as well, Cfb is a pid controller object, and the feedback compensator X is a zpk model.

```
[Cfb,Xfb] = getComponents(C2, 'feedback');
```

Decompose C2 using the filter configuration. Again, the components are a SISO pid controller and a zpk model representing the prefilter.

```
[Cfr,Xfr] = getComponents(C2, 'filter');
```

Input Arguments

C2 — 2-DOF PID controller

pid2 object | pidstd2 object

2-DOF PID controller to decompose, specified as a pid2 or pidstd2 controller object.

looptype — Loop structure

'feedforward' (default) | 'feedback' | 'filter'

Loop structure for decomposing the 2-DOF controller, specified as 'feedforward', 'feedback', or 'filter'. These correspond to the following control decompositions and architectures:

- 'feedforward' — C is a conventional SISO PID controller that takes the error signal as its input. X is a feedforward controller, as shown:

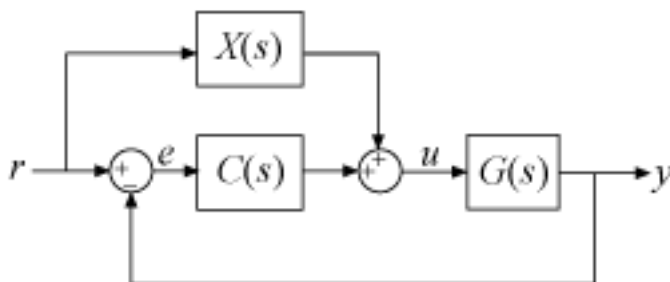

If C2 is a continuous-time, parallel-form controller, then the components are given by:

$$C(s) = K_p + \frac{K_i}{s} + \frac{K_d s}{T_f s + 1},$$

$$X(s) = (b - 1)K_p + \frac{(c - 1)K_d s}{T_f s + 1}.$$

The following command constructs the closed-loop system from r to y for the feedforward configuration.

`T = G*(C+X)*feedback(1,G*C);`

- 'feedback' — C is a conventional SISO PID controller that takes the error signal as its input. X is a feedback controller from y to u , as shown:

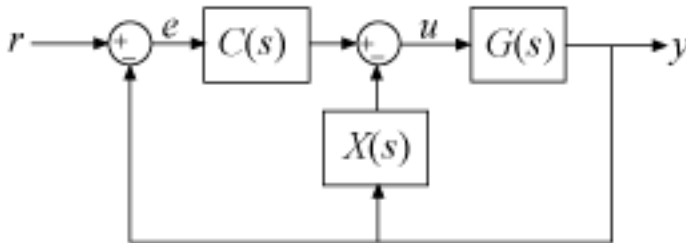

If C2 is a continuous-time, parallel-form controller, then the components are given by:

$$C(s) = bK_p + \frac{K_i}{s} + \frac{cK_d s}{T_f s + 1},$$

$$X(s) = (1 - b)K_p + \frac{(1 - c)K_d s}{T_f s + 1}.$$

The following command constructs the closed-loop system from r to y for the feedback configuration.

`T = G*C*feedback(1,G*(C+X));`

- 'filter' — X is a prefilter on the reference signal. C is a conventional SISO PID controller that takes as its input the difference between the filtered reference and the output, as shown:

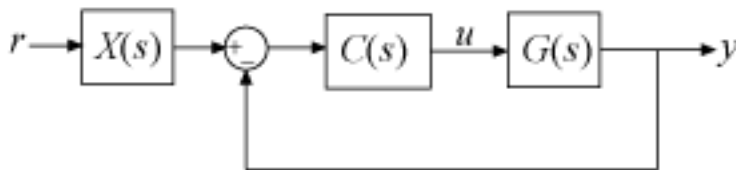

If C2 is a continuous-time, parallel-form controller, then the components are given by:

$$C(s) = K_p + \frac{K_i}{s} + \frac{K_d s}{T_f s + 1},$$

$$X(s) = \frac{(bK_p T_f + cK_d)s^2 + (bK_p + K_i T_f)s + K_i}{(K_p T_f + K_d)s^2 + (K_p + K_i T_f)s + K_i}.$$

The following command constructs the closed-loop system from r to y for the filter configuration.

```
T = X*feedback(G*C,1);
```

The formulas shown above pertain to continuous-time, parallel-form controllers. Standard-form controllers and controllers in discrete time can be decomposed into analogous configurations. The `getComponents` command works on all 2-DOF PID controller objects.

Output Arguments

C — SISO PID controller

`pid` object | `pidstd` object

SISO PID controller, returned as a `pid` or `pidstd` controller object. The form of `C` corresponds to the form of the input controller `C2`. For example, if `C2` is a standard-form `pidstd2` controller, then `C` is a `pidstd` object.

The precise functional form of `C` depends on the loop structure you specify with the `looptype` argument, as described in “Input Arguments” on page 2-381.

X — SISO control component

`zpk` model

SISO control component, specified as a zero-pole-gain (`zpk`) model. The precise functional form of `X` depends on the loop structure you specify with the `looptype` argument, as described in “Input Arguments” on page 2-381.

Version History

Introduced in R2015b

See Also

`pid2` | `pidstd2` | `make1DOF` | `make2DOF`

Topics

“Decompose a 2-DOF PID Controller into SISO Components”

“Two-Degree-of-Freedom PID Controllers”

getData

Get current values of tunable-surface coefficients

Syntax

```
Kco = getData(K)
KcoJ = getData(K,J)
```

Description

`Kco = getData(K)` extracts the current value of a tunable surface. `K` is a `tunableSurface` object that represents the parametric gain surface:

$$K(n(\sigma)) = \gamma[K_0 + K_1F_1(n(\sigma)) + \dots + K_MF_M(n(\sigma))],$$

where:

- σ is a vector of scheduling variables.
- $n(\sigma)$ is a normalization function (see the `Normalization` property of `tunableSurface`).
- γ is a scaling factor (see the `Normalization` property of `tunableSurface`).
- F_1, \dots, F_M are basis functions.
- K_0, \dots, K_M are tunable coefficients.

`getData` evaluates `K` at the current values of the coefficients K_0, \dots, K_M .

`KcoJ = getData(K, J)` extracts the current value of the coefficient of the J th basis function F_J . Use $J = 0$ to get the constant coefficient K_0 .

Input Arguments

K — Gain surface

`tunableSurface` object

Gain surface, specified as a `tunableSurface` object.

J — Index of basis function

nonnegative integer

Index of basis function, specified as a nonnegative integer. To extract the constant coefficient K_0 , use $J = 0$.

Output Arguments

Kco — Current coefficient values

array

Current coefficient values of the tunable surface, returned as an array.

If the tunable surface K is a scalar-valued gain, then the length of K is $(M+1)$, where M is the number of basis functions in the parameterization. For example, if K represents the tunable gain surface:

$$K(\alpha, V) = K_0 + K_1\alpha + K_2V + K_3\alpha V,$$

then K_{co} is the 1-by-4 vector $[K_0, K_1, K_2, K_3]$.

For array-valued gains, each coefficient expands to the I/O dimensions of the gain. These expanded coefficients are concatenated horizontally in K_{co} . (See `tunableSurface`.) For example, for a two-input, two-output gain surface, K_{co} has dimensions $[2, 2(M+1)]$.

KcoJ — Coefficient of J th basis function

scalar | array

Coefficient of the J th basis function in the tunable surface parameterization, returned as a scalar or an array.

If the tunable surface K is a scalar-valued gain, then K_{coJ} is a scalar. If K is an array-valued gain, then K_{coJ} is an array that matches the I/O dimensions of the gain.

Version History

Introduced in R2015b

See Also

`tunableSurface` | `setData` | `evalSurf` | `viewSurf`

getDelayModel

State-space representation of internal delays

Syntax

```
[H,tau] = getDelayModel(sys)
[A,B1,B2,C1,C2,D11,D12,D21,D22,E,tau] = getDelayModel(sys)
```

Description

`[H,tau] = getDelayModel(sys)` decomposes a state-space model `sys` with internal delays into a delay-free state-space model, `H`, and a vector of internal delays, `tau`. The relationship among `sys`, `H`, and `tau` is shown in the following diagram.

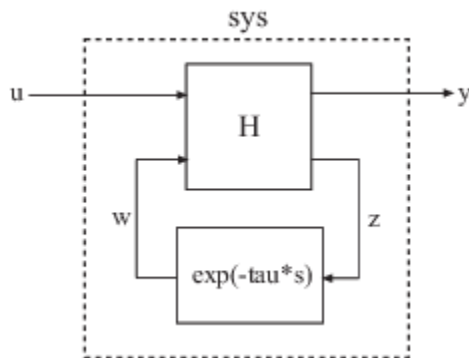

`[A,B1,B2,C1,C2,D11,D12,D21,D22,E,tau] = getDelayModel(sys)` returns the set of state-space matrices and internal delay vector, `tau`, that explicitly describe the state-space model `sys`. These state-space matrices are defined by the state-space equations:

- Continuous-time `sys`:

$$E \frac{dx(t)}{dt} = Ax(t) + B_1u(t) + B_2w(t)$$

$$y(t) = C_1x(t) + D_{11}u(t) + D_{12}w(t)$$

$$z(t) = C_2x(t) + D_{21}u(t) + D_{22}w(t)$$

$$w(t) = z(t - \tau)$$

- Discrete-time `sys`:

$$Ex[k + 1] = Ax[k] + B_1u[k] + B_2w[k]$$

$$y[k] = C_1x[k] + D_{11}u[k] + D_{12}w[k]$$

$$z[k] = C_2x[k] + D_{21}u[k] + D_{22}w[k]$$

$$w[k] = z[k - \tau]$$

Input Arguments

sys

Any state-space (ss) model.

Output Arguments

H

Delay-free state-space model (ss). H results from decomposing `sys` into a delay-free component and a component $\exp(-\tau s)$ that represents all internal delays.

If `sys` has no internal delays, H is equal to `sys`.

tau

Vector of internal delays of `sys`, expressed in the time units of `sys`. The vector `tau` results from decomposing `sys` into a delay-free state-space model H and a component $\exp(-\tau s)$ that represents all internal delays.

If `sys` has no internal delays, `tau` is empty.

A, B1, B2, C1, C2, D11, D12, D21, D22, E

Set of state-space matrices that, with the internal delay vector `tau`, explicitly describe the state-space model `sys`.

For explicit state-space models ($E = I$, or `sys.e = []`), the output $E = []$.

If `sys` has no internal delays, the outputs B2, C2, D12, D21, and D22 are all empty (`[]`).

Examples

Get Delay-Free State-Space Model and Internal Delay

Decompose the following closed-loop system with internal delay into a delay-free component and a component representing the internal delay.

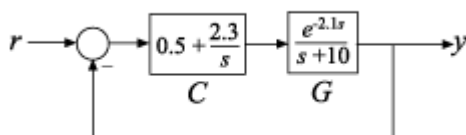

Create the closed-loop model `sys` from `r` to `y`.

```
G = tf(1,[1 10], 'InputDelay',2.1);
C = pid(0.5,2.3);
sys = feedback(C*G,1);
```

`sys` is a state-space (ss) model with an internal delay that arises from closing the feedback loop on a plant with an input delay.

Decompose `sys` into a delay-free state-space model and the value of the internal delay.

```
[H,tau] = getDelayModel(sys);
```

Confirm that the internal delay matches the original input delay on the plant.

```
tau
```

```
tau = 2.1000
```

Version History

Introduced in R2006a

See Also

`setDelayModel`

Topics

“Internal Delays”

getGainCrossover

Crossover frequencies for specified gain

Syntax

```
wc = getGainCrossover(sys,gain)
```

Description

`wc = getGainCrossover(sys,gain)` returns the vector `wc` of frequencies at which the frequency response of the dynamic system model, `sys`, has principal gain of `gain`. For SISO systems, the principal gain is the frequency response. For MIMO models, the principal gain is the largest singular value of `sys`.

Examples

Unity Gain Crossover

Find the 0dB crossover frequencies of a single-loop control system with plant given by:

$$G(s) = \frac{1}{(s + 1)^3},$$

and PI controller given by:

$$C(s) = 1.14 + \frac{0.454}{s}.$$

```
G = zpk([], [-1, -1, -1], 1);
C = pid(1.14, 0.454);
sys = G*C;
wc = getGainCrossover(sys, 1)
```

```
wc = 0.5214
```

The 0 dB crossover frequencies are the frequencies at which the open-loop response `sys = G*C` has unity gain. Because this system only crosses unity gain once, `getGainCrossover` returns a single value.

Notch Filter Stopband

Find the 20 dB stopband of

$$\text{sys} = \frac{s^2 + 0.05s + 100}{s^2 + 5s + 100}.$$

`sys` is a notch filter centered at 10 rad/s.

```
sys = tf([1 0.05 100],[1 5 100]);  
gain = db2mag(-20);  
wc = getGainCrossover(sys,gain)  
  
wc = 2×1  
  
    9.7531  
   10.2531
```

The `db2mag` command converts the gain value of -20 dB to absolute units. The `getGainCrossover` command returns the two frequencies that define the stopband.

Input Arguments

sys — Input dynamic system

dynamic system model

Input dynamic system, specified as any SISO or MIMO dynamic system model.

gain — Input gain

positive real scalar

Input gain in absolute units, specified as a positive real scalar.

- If `sys` is a SISO model, the gain is the frequency response magnitude of `sys`.
- If `sys` is a MIMO model, gain means the largest singular value of `sys`.

Output Arguments

wc — Crossover frequencies

column vector

Crossover frequencies, returned as a column vector. This vector lists the frequencies at which the gain or largest singular value of `sys` is `gain`.

Algorithms

`getGainCrossover` computes gain crossover frequencies using structure-preserving eigensolvers from the SLICOT library. For more information about the SLICOT library, see <http://slicot.org>.

Version History

Introduced in R2012a

See Also

`freqresp` | `bode` | `sigma` | `bandwidth` | `getPeakGain`

Topics

“Dynamic System Models”

getGoal

Evaluate variable tuning goal at specified design point

Syntax

```
TG = getGoal(VG, 'index', k)
TG = getGoal(VG, 'index', k1, k2, ...)
TG = getGoal(VG, 'value', x1, x2, ...)
```

Description

When tuning controllers for multiple operating conditions, `varyingGoal` lets you adjust the tuning objectives as a function of the design point. Use `getGoal` to evaluate a variable goal at a particular design point or for particular values of the sampling variables.

`TG = getGoal(VG, 'index', k)` returns the effective tuning goal at the *k*th design point. The absolute index *k* is relative to the arrays of parameter values in the `Parameters` property of the varying goal `VG`. If you have specified `VG.SamplingGrid`, then *k* is relative to the grid of design points in that property.

`TG = getGoal(VG, 'index', k1, k2, ...)` returns the effective tuning goal at the design point with coordinates (k_1, k_2, \dots) . These coordinates are indices into the multidimensional arrays in `VG.Parameters` and `VG.SamplingGrid`. This syntax is useful when your design grid includes multiple scheduling variables.

`TG = getGoal(VG, 'value', x1, x2, ...)` returns the effective tuning goal at the design point whose scheduling-variable values are (x_1, x_2, \dots) . Use this syntax only if you have specified design points in `VG.SamplingGrid`. For example, if `VG.SamplingGrid` specifies a grid of design points (a, b) , then `TG = getGoal(VG, 'value', -1, 3)` returns the tuning goal at the design point $(a, b) = (-1, 3)$. If (x_1, x_2, \dots) does not match any point in `VG.SamplingGrid`, then `getGoal` returns the nearest point, in a relative sense.

Examples

Get Goal at Design Point from Varying Tuning Goal

Suppose you use the following 5-by-5 grid of design points to tune your controller.

```
[alpha, V] = ndgrid(linspace(0, 20, 5), linspace(700, 1300, 5));
```

Create a variable tuning goal that specifies gain and phase margins at a signal named 'u' that vary across a grid of design points.

```
[GM, PM] = ndgrid(linspace(7, 20, 5), linspace(45, 70, 5));
FH = @(gm, pm) TuningGoal.Margins('u', gm, pm);
VG = varyingGoal(FH, GM, PM);
```

Use the grid to specify the `SamplingGrid` property of `VG`.

```
VG.SamplingGrid = struct('alpha', alpha, 'V', V);
```

Evaluate this variable design goal at $(\alpha, V) = (5, 1150)$. This point is the second α value and the fourth V value, so you can index into the `varyingGoal` using $(k1, k2) = (2, 4)$.

```
TGi = getGoal(VG, 'index', 2, 4);
```

Because you have the specific (α, V) values at which you want the tuning goal, you can use those values instead of indexing.

```
TGv = getGoal(VG, 'value', 5, 1150)
```

```
TGv =
  Margins with properties:

    GainMargin: 10.2500
    PhaseMargin: 63.7500
    ScalingOrder: 0
        Focus: [0 Inf]
    Location: {'u'}
        Models: 17
    Openings: {0x1 cell}
        Name: ''
```

Input Arguments

VG — Varying tuning goal

`varyingGoal` object

Varying tuning goal, specified as a `varyingGoal` object. VG captures the variation of a tuning goal over a grid of design points for gain-scheduled tuning (see `tunableSurface`).

k — Index into design-point grid

integer

Index into design point grid, specified as an integer. You can provide one integer index, k , or multiple indices $k1, k2, \dots$.

If you provide a single index, k , then `getGoal` treats k as a linear index into the parameter arrays of VG. `Parameters` or the structures of VG. `SamplingGrid` that specify the design points.

- If VG varies over a 1-D sampling grid (one scheduling variable), then $TG = \text{getGoal}(VG, 'index', k)$ returns the tuning goal for the k th entry in VG. `Parameters`.
- If VG varies over two or more scheduling-variables, then $TG = \text{getGoal}(VG, 'index', k)$ returns the k th entry in that grid, determined by linear indexing. (See “Array Indexing”.)

If you provide multiple indices, $k1, k2, \dots$, then `getGoal` treats them as indices into the multidimensional arrays of VG. `Parameters` or VG. `SamplingGrid`.

x — Variable value at design point

scalar

Variable value at design point, specified as a scalar. Use inputs $x1, x2, \dots$, to get the tuning goal for a particular set of scheduling-variable values. Provide as many values as you have scheduling variables in your system. For example, if the operating conditions are described by two scheduling

variables (a, b) , then use $(x1, x2)$ to specify the (a, b) value at which you want to extract the tuning goal.

Output Arguments

TG — Tuning goal at design point

TuningGoal object | []

Tuning goal at the specified design point, returned as a TuningGoal object. If any of the tuning goal parameters is NaN at the specified design point, then TG = []. (See varyingGoal).

Version History

Introduced in R2017b

See Also

varyingGoal | tunableSurface

getIOTransfer

Closed-loop transfer function from generalized model of control system

Syntax

```
H = getIOTransfer(T,in,out)
H = getIOTransfer(T,in,out,openings)
```

Description

`H = getIOTransfer(T,in,out)` returns the transfer function from specified inputs to specified outputs of a control system, computed from a closed-loop generalized model of the control system.

`H = getIOTransfer(T,in,out,openings)` returns the transfer function calculated with one or more loops open.

Examples

Closed-Loop Responses of Control System Model

Analyze responses of a control system by using `getIOTransfer` to compute responses between various inputs and outputs of a closed-loop model of the system.

Consider the following control system.

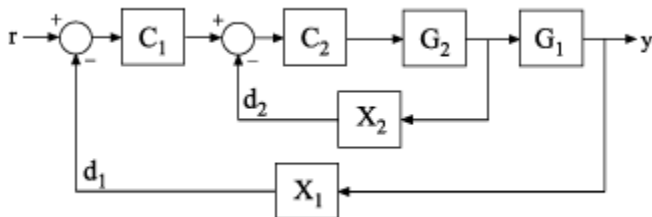

Create a `genss` model of the system by specifying and connecting the numeric plant models `G1` and `G2`, the tunable controllers `C1` and `C2`, and the `AnalysisPoint` blocks `X1` and `X2` that mark potential loop-opening or signal injection sites.

```
G1 = tf(10,[1 10]);
G2 = tf([1 2],[1 0.2 10]);
C1 = tunablePID('C','pi');
C2 = tunableGain('G',1);
X1 = AnalysisPoint('X1');
X2 = AnalysisPoint('X2');
T = feedback(G1*feedback(G2*C2,X2)*C1,X1);
T.InputName = 'r';
T.OutputName = 'y';
```

If you tuned the free parameters of this model (for example, using the tuning command `systemtune`), you might want to analyze the tuned system performance by examining various system responses.

For example, examine the response at the output, y , to a disturbance injected at the point d_1 .

```
H1 = getIOTransfer(T, 'X1', 'y');
```

H1 represents the closed-loop response of the control system to a disturbance injected at the implicit input associated with the `AnalysisPoint` block X1, which is the location of d_1 :



H1 is a `genss` model that includes the tunable blocks of T. If you have tuned the free parameters of T, H1 allows you to validate the disturbance response of your tuned system. For example, you can use analysis commands such as `bodeplot` or `stepplot` to examine the responses of H1. You can also use `getValue` to obtain the current value of H1, in which all the tunable blocks are evaluated to their current numeric values.

Similarly, examine the response at the output to a disturbance injected at the point d_2 .

```
H2 = getIOTransfer(T, 'X2', 'y');
```

You can also generate a two-input, one-output model representing the response of the control system to simultaneous disturbances at both d_1 and d_2 . To do so, provide `getIOTransfer` with a cell array that specifies the multiple input locations.

```
H = getIOTransfer(T, {'X1', 'X2'}, 'y');
```

Responses with Some Loops Open and Others Closed

Compute the response from r to y of the following cascaded control system, with the inner loop open, and the outer loop closed.

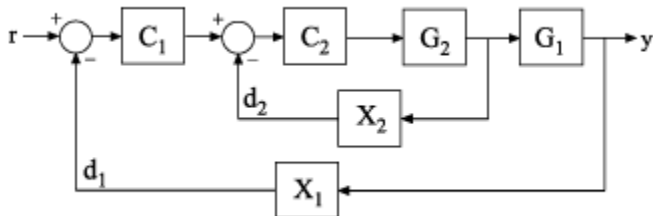

Create a `genss` model of the system by specifying and connecting the numeric plant models G1 and G2, the tunable controllers C1 and C2, and the `AnalysisPoint` blocks X1 and X2 that mark potential loop-opening or signal injection sites.

```
G1 = tf(10,[1 10]);
G2 = tf([1 2],[1 0.2 10]);
```

```

C1 = tunablePID('C','pi');
C2 = tunableGain('G',1);
X1 = AnalysisPoint('X1');
X2 = AnalysisPoint('X2');
T = feedback(G1*feedback(G2*C2,X2)*C1,X1);
T.InputName = 'r';
T.OutputName = 'y';

```

If you tuned the free parameters of this model (for example, using the tuning command `systemtune`), you might want to analyze the tuned system performance by examining various system responses.

For example, compute the response of the system with the inner loop open, and the outer loop closed.

```
H = getIOTransfer(T,'r','y','X2');
```

By default, the loops are closed at the analysis points X1 and X2. Specifying 'X2' for the `openings` argument causes `getIOTransfer` to open the loop at X2 for the purposes of computing the requested transfer from *r* to *y*. The switch at X1 remains closed for this computation.

Input Arguments

T — Model of control system

generalized state-space model

Model of a control system, specified as a generalized state-space model (`genss`).

in — Input to extracted transfer function

character vector | cell array of character vectors

Input to extracted transfer function, specified as a character vector or cell array of character vectors. To extract a multiple-input transfer function from the control system, use a cell array of character vectors. Each specified input must match either:

- An input of the control system model *T*; that is, a channel name from *T.InputName*.
- An analysis point in *T*, corresponding to a channel of an `AnalysisPoint` block in *T*. To get the list of available analysis points in *T*, use `getPoints(T)`.

When you specify an analysis point as an input *in*, `getIOTransfer` uses the input implicitly associated with the `AnalysisPoint` channel, arranged as follows.



This input signal models a disturbance entering at the output of the switch.

If an analysis point has the same name as an input of *T*, then `getIOTransfer` uses the input of *T*.

Example: `{ 'r', 'X1' }`

out — Output of extracted transfer function

character vector | cell array of character vectors

Output of extracted transfer function, specified as a character vector or cell array of character vectors. To extract a multiple-output transfer function from the control system, use a cell array of character vectors. Each specified output must match either:

- An output of the control system model `T`; that is, a channel name from `T.OutputName`.
- An analysis point in `T`, corresponding to a channel of an `AnalysisPoint` block in `T`. To get the list of available analysis points in `T`, use `getPoints(T)`.

When you specify an analysis point as an output `out`, `getIOTransfer` uses the output implicitly associated with the `AnalysisPoint` channel, arranged as follows.



If an analysis point has the same name as an output of `T`, then `getIOTransfer` uses the output of `T`.

Example: `{ 'y' , 'X2' }`

openings — Locations for opening feedback loops

character vector | cell array of character vectors

Locations for opening feedback loops for computation of the response from `in` to `out`, specified as a character vector or cell array of character vectors that identify analysis points in `T`. Analysis points are marked by `AnalysisPoint` blocks in `T`. To get the list of available analysis points in `T`, use `getPoints(T)`.

Use `openings` when you want to compute the response from `in` to `out` with some loops in the control system open. For example, in a cascaded loop configuration, you can calculate the response from the system input to the system output with the inner loop open.

Output Arguments

H — Closed-loop transfer function

generalized state-space model

Closed-loop transfer function of the control system `T` from `in` to `out`, returned as a generalized state-space model (`genss`).

- If both `in` and `out` specify a single signal, then `T` is a SISO `genss` model.
- If `in` or `out` specifies multiple signals, then `T` is a MIMO `genss` model.

Tips

- You can use `getIOTransfer` to extract various subsystem responses, given a generalized model of the overall control system. This is useful for validating responses of a control system that you tune with tuning commands such as `systeme`.

For example, in addition to evaluating the overall response of a tuned control system from inputs to outputs, you can use `getIOTransfer` to extract the transfer function from a disturbance input

to a system output. Evaluate the responses of that transfer function (such as with `step` or `bode`) to confirm that the tuned system meets your disturbance rejection requirements.

- `getIOTransfer` is the `genss` equivalent to the Simulink Control Design `getIOTransfer` command, which works with the `sLTuner` and `sLLinearizer` interfaces. Use the Simulink Control Design command when your control system is modeled in Simulink.

Version History

Introduced in R2012b

See Also

`AnalysisPoint` | `getPoints` | `genss` | `getLoopTransfer` | `systune` | `getIOTransfer`

getLFTModel

Decompose generalized LTI model

Syntax

```
[H,B,S] = getLFTModel(M)
```

Description

`[H,B,S] = getLFTModel(M)` extracts the components H , B , and S that make up the Generalized matrix or Generalized LTI model M . The model M decomposes into H , B , and S . These components are related to M as shown in the following illustration.

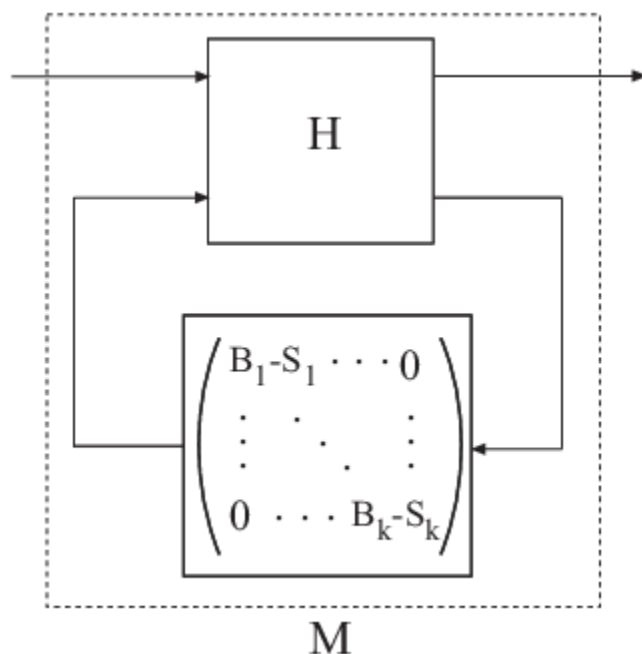

The cell array B contains the Control Design Blocks of M . The component H is a numeric matrix, `ss` model, or `frd` model that describes the fixed portion of M and the interconnections between the blocks of B . The matrix $S = \text{blkdiag}(S_1, \dots, S_k)$ contains numerical offsets that ensure that the interconnection is well-defined when the current (nominal) value of M is finite.

You can recombine H , B , and S into M using `lft`, as follows:

```
M = lft(H,blkdiag(B{:})-S);
```

Input Arguments

M

Generalized LTI model (`genss` or `genfrd`) or Generalized matrix (`genmat`).

Output Arguments

H

Matrix, `ss` model, or `frd` model describing the numeric portion of `M` and how it the numeric portion is connected to the Control Design Blocks of `M`.

B

Cell array of Control Design Blocks (for example, `realp` or `tunableSS`) of `M`.

S

Matrix of offset values. The software might introduce offsets when you build a Generalized model to ensure that `H` is finite when the current (nominal) value of `M` is finite.

Tips

- `getLFTModel` gives you access to the internal representation of Generalized LTI models and Generalized Matrices. For more information about this representation, see “Internal Structure of Generalized Models”.

Version History

Introduced in R2011a

See Also

`genfrd` | `genss` | `genmat` | `lft` | `getValue` | `nblocks`

Topics

“Generalized Matrices”

“Generalized and Uncertain LTI Models”

“Models with Tunable Coefficients”

“Internal Structure of Generalized Models”

getLoopTransfer

Open-loop transfer function of control system represented by `genss` model

Syntax

```
L = getLoopTransfer(T,Locations)
L = getLoopTransfer(T,Locations,sign)
L = getLoopTransfer(T,Locations,sign,openings)
```

Description

`L = getLoopTransfer(T,Locations)` returns the point-to-point open-loop transfer function of a control system at specified analysis points. The control system is represented by a generalized state-space model `T`, containing the analysis points specified by `Locations`. The point-to-point open-loop transfer function is the response obtained by opening the loop at the specified locations, injecting signals at those locations, and measuring the return signals at the same locations.

`L = getLoopTransfer(T,Locations,sign)` specifies the feedback sign for calculating the open-loop response. The relationship between the closed-loop response `T` and the open-loop response `L` is `T = feedback(L,1,sign)`.

`L = getLoopTransfer(T,Locations,sign,openings)` specifies additional loop-opening locations to open for computing the open-loop response at `Locations`.

Examples

Open-Loop Transfer Function at Analysis Point

Compute the open-loop response of the following control system model at an analysis point specified by an `AnalysisPoint` block, `X`.

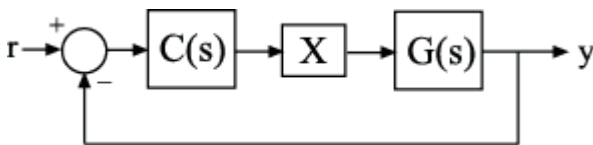

Create a model of the system by specifying and connecting a numeric LTI plant model, `G`, a tunable controller, `C`, and the `AnalysisPoint`, `X`.

```
G = tf([1 2],[1 0.2 10]);
C = tunablePID('C','pi');
X = AnalysisPoint('X');
T = feedback(G*X*C,1);
```

`T` is a `genss` model that represents the closed-loop response of the control system from `r` to `y`. The model contains `AnalysisPoint` block `X`, which identifies the potential loop-opening location.

Calculate the open-loop point-to-point loop transfer at location `X`.

```
L = getLoopTransfer(T, 'X');
```

This command computes the transfer function you would obtain by opening the loop at X, injecting a signal into G, and measuring the resulting response at the output of C. By default, `getLoopTransfer` computes the positive feedback transfer function, which is the loop transfer assuming that the loop will be closed at X without a change of sign. In this example, the positive feedback transfer function is $L(s) = -C(s)G(s)$.

The output L is a `genss` model that includes the tunable block C. You can use `getValue` to obtain the current value of L, in which all the tunable blocks of L are evaluated to their current numeric value.

Stability Margins of Closed-Loop System

Compute the stability margins of the following closed-loop system at an analysis point specified by an `AnalysisPoint` block, X.

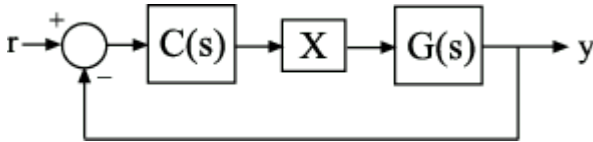

Create a model of the system by specifying and connecting a numeric LTI plant model G, a tunable controller C, and the `AnalysisPoint` block X.

```
G = tf([1 2],[1 0.2 10]);
C = pid(0.1,1.5);
X = AnalysisPoint('X');
T = feedback(G*X*C,1);
```

T is a `genss` model that represents the closed-loop response of the control system from r to y . The model contains the `AnalysisPoint` block X that identifies the potential loop-opening location.

By default, `getLoopTransfer` returns a transfer function L at the specified analysis point such that $T = \text{feedback}(L, 1, +1)$. However, `margin` assumes negative feedback, so that `margin(L)` computes the stability margin of the negative feedback closed-loop system `feedback(L, 1)`. Therefore, to analyze the stability margins, set the `sign` input argument to -1 to extract a transfer function L such that $T = \text{feedback}(L, 1)$. In this example, this transfer function is $L(s) = C(s)G(s)$.

```
L = getLoopTransfer(T, 'X', -1);
```

This command computes the open-loop transfer function from the input of G to the output of C, assuming that the loop is closed with negative feedback, so that you can use it with analysis commands like `margin`.

```
[Gm,Pm] = margin(L)
```

```
Gm = 1.4100
```

```
Pm = 4.9486
```

Transfer Function with Additional Loop Openings

Compute the open-loop response of the inner loop of the following cascaded control system, with the outer loop open.

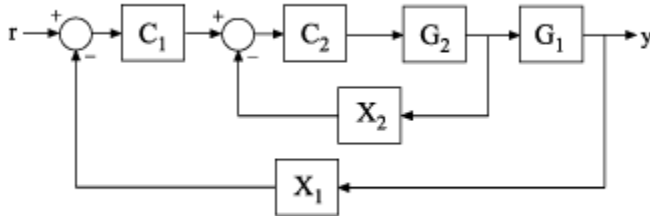

Create a model of the system by specifying and connecting the numeric plant models G1 and G2, the tunable controllers C1, and the AnalysisPoint blocks X1 and X2 that mark potential loop-opening locations.

```
G1 = tf(10,[1 10]);
G2 = tf([1 2],[1 0.2 10]);
C1 = tunablePID('C','pi');
C2 = tunableGain('G',1);
X1 = AnalysisPoint('X1');
X2 = AnalysisPoint('X2');
T = feedback(G1*feedback(G2*C2,X2)*C1,X1);
```

Compute the negative-feedback open-loop response of the inner loop, at the location X2, with the outer loop opened at X1.

```
L = getLoopTransfer(T,'X2',-1,'X1');
```

By default, the loop is closed at the analysis-point location marked by the AnalysisPoint block X1. Specifying 'X1' for the openings argument causes getLoopTransfer to open the loop at X1 for the purposes of computing the requested loop transfer at X2. In this example, the negative-feedback open-loop response $L(s) = G_2(s)C_2(s)$.

Input Arguments

T — Model of control system

generalized state-space model

Model of a control system, specified as a Generalized State-Space (genss) Model. Locations at which you can open loops and perform open-loop analysis are marked by AnalysisPoint blocks in T.

Locations — Analysis-point locations

character vector | cell array of character vectors

Analysis-point locations in the control system model at which to compute the open-loop point-to-point response, specified as a character vector or a cell array of character vectors that identify analysis-point locations in T.

Analysis-point locations are marked by `AnalysisPoint` blocks in `T`. An `AnalysisPoint` block can have single or multiple channels. The `Location` property of an `AnalysisPoint` block gives names to these feedback channels.

The name of any channel in an `AnalysisPoint` block in `T` is a valid entry for the `Locations` argument to `getLoopTransfer`. To get a full list of available analysis points in `T`, use `getPoints(T)`.

`getLoopTransfer` computes the open-loop response you would obtain by injecting a signal at the implicit input associated with an `AnalysisPoint` channel, and measuring the response at the implicit output associated with the channel. These implicit inputs and outputs are arranged as follows.



L is the open-loop transfer function from `in` to `out`.

sign — Sign of transfer function for analysis

+1 (default) | -1

Sign of open-loop transfer function for analysis, specified as +1 or -1.

By default, for an input closed-loop system `T`, the function returns a transfer function L at the specified analysis point, such that $T = \text{feedback}(L, 1, +1)$. However, certain analysis commands that take an open-loop response assume that the loop will be closed with negative feedback. For instance, `margin(L)` computes the stability margin of the negative feedback closed-loop system `feedback(L, 1)`. Similarly, the stability margins you can obtain by right-clicking on a `bode` plot make the same assumption. Therefore, when you use `getLoopTransfer` to extract an open-loop transfer function with the purpose of analyzing closed-loop stability, you can set `sign = -1` to extract a transfer function L such that $T = \text{feedback}(L, 1)$.

For example, consider the following system, where T is the closed-loop transfer function from r to y .

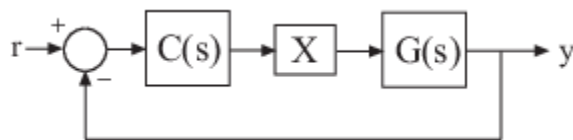

By default, $L = \text{getLoopTransfer}(T, 'X')$ computes the transfer function $L = -C(s)G(s)$, such that $T = \text{feedback}(L, 1, +1)$. To compute the stability margins at X using the `margin` command, which assumes negative feedback, you must compute a transfer function $L = C(s)G(s)$, such that $T = \text{feedback}(L, 1)$. To do so, use $L = \text{getLoopTransfer}(T, 'X', -1)$.

openings — Additional locations for opening feedback loops

character vector | cell array of character vectors

Additional locations for opening feedback loops for computation of the open-loop response, specified as character vector or cell array of character vectors that identify analysis-point locations in `T`. Analysis-point locations are marked by `AnalysisPoint` blocks in `T`. Any channel name contained in the `Location` property of an `AnalysisPoint` block in `T` is a valid entry for `openings`.

Use `openings` when you want to compute the open-loop response at one analysis-point location with other loops also open at other locations. For example, in a cascaded loop configuration, you can calculate the inner loop open-loop response with the outer loop also open. Use `getPoints(T)` to get a full list of available analysis-point locations in `T`.

Output Arguments

L — Point-to-point open-loop response

generalized state-space model

Point-to-point open-loop response of the control system `T` measured at the analysis points specified by `Locations`, returned as a generalized state-space (`genss`) model.

- If `Locations` specifies a single analysis point, then `L` is a SISO `genss` model. In this case, `L` represents the response obtained by opening the loop at `Locations`, injecting signals and measuring the return signals at the same location.
- If `Locations` is a vector signal, or specifies multiple analysis points, then `L` is a MIMO `genss` model. In this case, `L` represents the open-loop MIMO response obtained by opening loops at all locations listed in `Locations`, injecting signals and measuring the return signals at those locations.

Tips

- You can use `getLoopTransfer` to extract open-loop responses given a generalized model of the overall control system. This is useful, for example, for validating open-loop responses of a control system that you tune with the a tuning command such as `systune` .
- `getLoopTransfer` is the `genss` equivalent to the Simulink Control Design command `getLoopTransfer`, which works with the `sLTuner` and `sLLinearizer` interfaces. Use the Simulink Control Design command when your control system is modeled in Simulink.

Version History

Introduced in R2012b

See Also

`AnalysisPoint` | `getPoints` | `genss` | `getIOTransfer` | `systune` | `getLoopTransfer`

getoptions

Package:

Return plot options handle or plot options property

Syntax

```
p = getoptions(h)
p = getoptions(h,propertyName)
```

Description

You can use `getoptions` to obtain the plot handle options or properties list and use it to customize the plot, such as modify the axes labels, limits and units. For a list of the properties and values available for each plot type, see “Properties and Values Reference”. To customize an existing plot using the plot handle:

- 1 Obtain the plot handle
- 2 Use `getoptions` to obtain the option set
- 3 Update the plot using `setoptions` to modify the required options

For more information, see “Customizing Response Plots from the Command Line”.

`p = getoptions(h)` returns the plot options handle associated with plot handle `h`. `p` contains all the settable options for a given response plot.

`p = getoptions(h,propertyName)` returns the specified options property, `propertyName`, for the plot with handle `h`. You can use this to interrogate a plot handle.

Examples

Impulse Plot with Specified Grid Color

For this example, consider a MIMO state-space model with 3 inputs, 3 outputs and 3 states. Create a impulse plot with red colored grid lines.

Create the MIMO state-space model `sys_mimo`.

```
J = [8 -3 -3; -3 8 -3; -3 -3 8];
F = 0.2*eye(3);
A = -J\F;
B = inv(J);
C = eye(3);
D = 0;
sys_mimo = ss(A,B,C,D);
size(sys_mimo)
```

State-space model with 3 outputs, 3 inputs, and 3 states.

Create an impulse plot with plot handle `h` and use `getoptions` for a list of the options available.

```
h = impulseplot(sys_mimo)
```

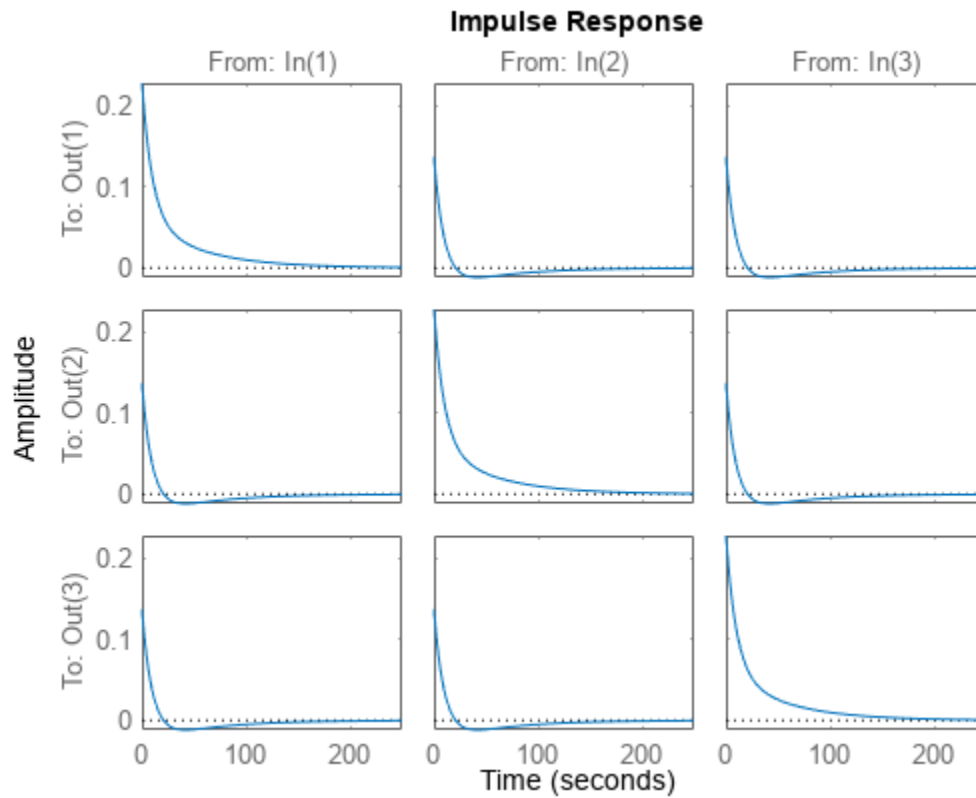

```
h =
```

```
respack.timeplot
```

```
p = getoptions(h)
```

```
p =
```

```

        Normalize: 'off'
    SettleTimeThreshold: 0.0200
        RiseTimeLimits: [0.1000 0.9000]
            TimeUnits: 'seconds'
ConfidenceRegionNumberSD: 1
    IOGrouping: 'none'
    InputLabels: [1x1 struct]
    OutputLabels: [1x1 struct]
    InputVisible: {3x1 cell}
    OutputVisible: {3x1 cell}
        Title: [1x1 struct]
        XLabel: [1x1 struct]
        YLabel: [1x1 struct]
    TickLabel: [1x1 struct]
        Grid: 'off'
    GridColor: [0.1500 0.1500 0.1500]
        XLim: {3x1 cell}
        YLim: {3x1 cell}

```

```
XLimMode: {3x1 cell}
YLimMode: {3x1 cell}
```

Use `setoptions` to update the plot with the required customization.

```
setoptions(h, 'Grid', 'on', 'GridColor', [1 0 0]);
```

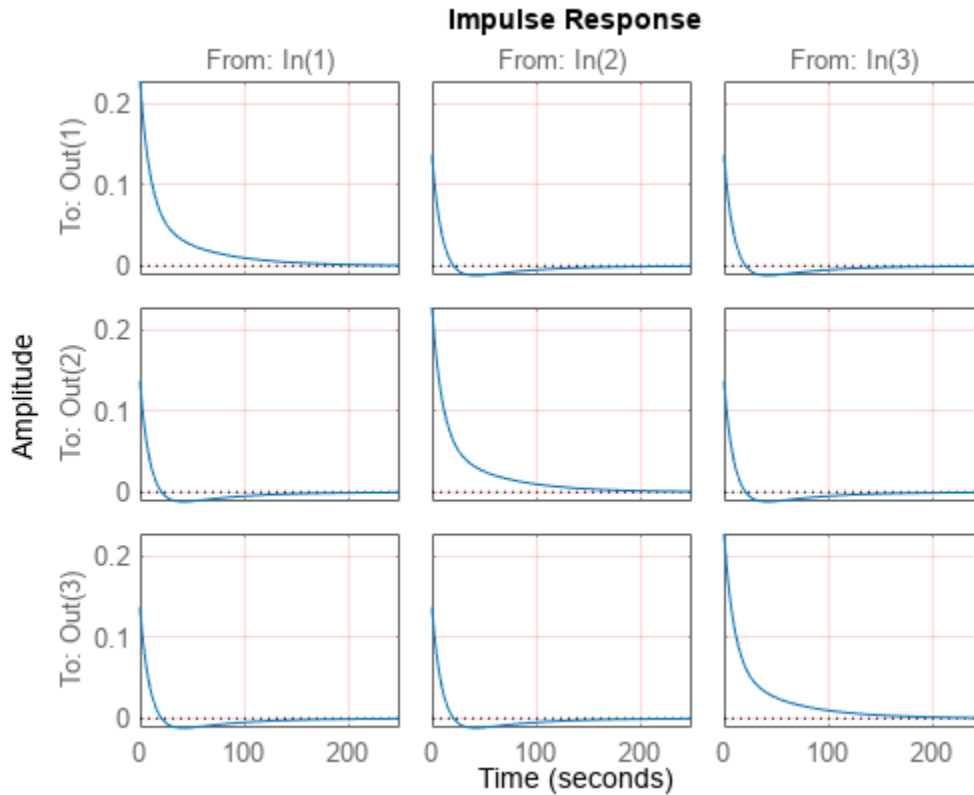

The impulse plot automatically updates when you call `setoptions`. For MIMO models, `impzplot` produces a grid of plots, each plot displaying the impulse response of one I/O pair.

Bode Plot with Specified Frequency Scale and Units

For this example, consider a MIMO state-space model with 3 inputs, 3 outputs and 3 states. Create a Bode plot with linear frequency scale, specify frequency units in Hz and turn the grid on.

Create the MIMO state-space model `sys_mimo`.

```
J = [8 -3 -3; -3 8 -3; -3 -3 8];
F = 0.2*eye(3);
A = -J\F;
B = inv(J);
C = eye(3);
D = 0;
sys_mimo = ss(A,B,C,D);
size(sys_mimo)
```

State-space model with 3 outputs, 3 inputs, and 3 states.

Create a Bode plot with plot handle `h` and use `getoptions` for a list of the options available.

```
h = bodeplot(sys_mimo);
```

```
p = getoptions(h)
```

```
p =
```

```

        FreqUnits: 'rad/s'
        FreqScale: 'log'
        MagUnits: 'dB'
        MagScale: 'linear'
        MagVisible: 'on'
    MagLowerLimMode: 'auto'
        PhaseUnits: 'deg'
        PhaseVisible: 'on'
        PhaseWrapping: 'off'
        PhaseMatching: 'off'
    PhaseMatchingFreq: 0
ConfidenceRegionNumberSD: 1
        MagLowerLim: 0
    PhaseMatchingValue: 0
PhaseWrappingBranch: -180
        IOGrouping: 'none'
    InputLabels: [1x1 struct]
    OutputLabels: [1x1 struct]
    InputVisible: {3x1 cell}
    OutputVisible: {3x1 cell}
        Title: [1x1 struct]
        XLabel: [1x1 struct]
        YLabel: [1x1 struct]
    TickLabel: [1x1 struct]
        Grid: 'off'
    GridColor: [0.1500 0.1500 0.1500]
        XLim: {3x1 cell}
        YLim: {6x1 cell}
    XLimMode: {3x1 cell}
    YLimMode: {6x1 cell}

```

Use `setoptions` to update the plot with the requires customization.

```
setoptions(h, 'FreqScale', 'linear', 'FreqUnits', 'Hz', 'Grid', 'on');
```

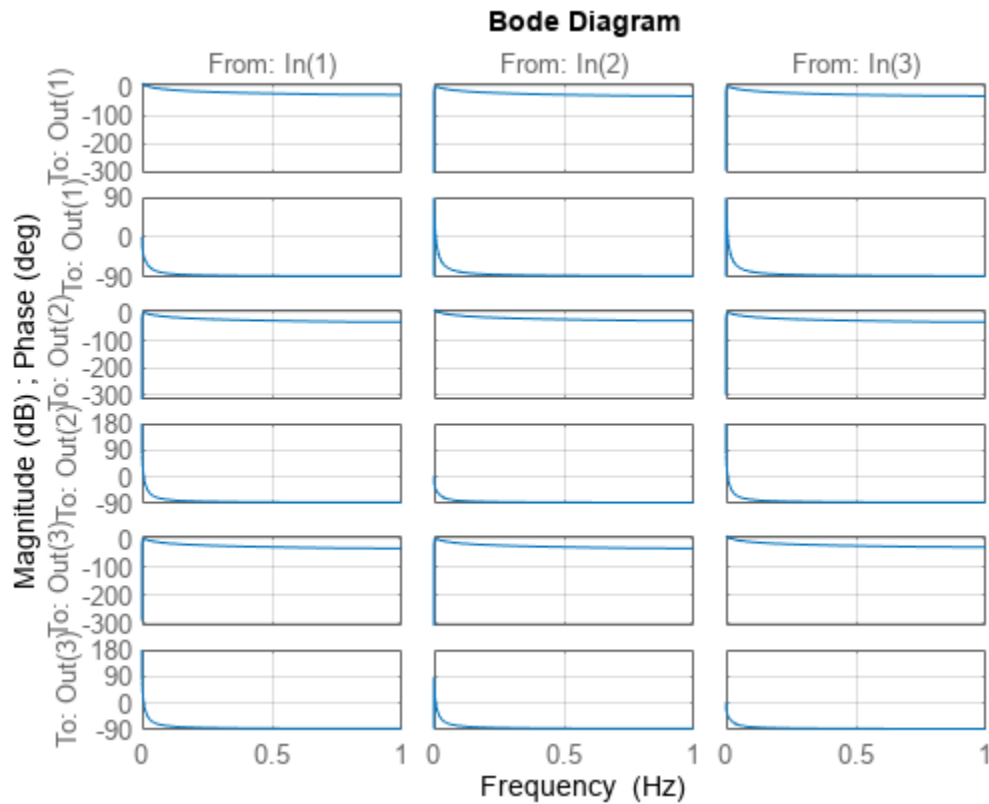

The Bode plot automatically updates when you call `setoptions`. For MIMO models, `bodeplot` produces an array of Bode plots, each plot displaying the frequency response of one I/O pair.

Input Arguments

h — Plot handle

plot handle object

Plot handle, specified as a plot handle object. For example, `h` is a `mpzplot` object for a pole-zero or I/O pole-zero plot.

propertyName — Specific property name

string | character vector

Specific property name, specified as a string or character vector. For a list of the properties and values available for each plot type, see “Properties and Values Reference”.

Output Arguments

p — Plot options handle

plot options handle object

Plot options handle, returned as a plot options handle object. For example, `p` is a `PZMapOptions` object for a pole-zero or I/O pole-zero plot.

Version History

Introduced before R2006a

See Also

setoptions

Topics

"Properties and Values Reference"

"Customizing Response Plots from the Command Line"

getPassiveIndex

Compute passivity index of linear system

Syntax

```
R = getPassiveIndex(G)
nu = getPassiveIndex(G, 'input')
rho = getPassiveIndex(G, 'output')
tau = getPassiveIndex(G, 'io')
DX = getPassiveIndex(G, dQ)

index = getPassiveIndex( ____, tol)
index = getPassiveIndex( ____, tol, fband)
[index, FI] = getPassiveIndex( ____)
[index, FI, Qout, dQout] = getPassiveIndex( ____ )
```

Description

`getPassiveIndex` computes various measures of the excess or shortage of passivity for a given system.

A linear system $G(s)$ is passive if all its I/O trajectories $(u(t), y(t))$ satisfy:

$$\int_0^T y(t)^T u(t) dt > 0,$$

for all $T > 0$. Equivalently, a system is passive if its frequency response is positive real, such that for all $\omega > 0$,

$$G(j\omega) + G(j\omega)^H > 0$$

(or the discrete-time equivalent).

`R = getPassiveIndex(G)` computes the relative passivity index. G is passive when R is less than one. R measures the relative excess ($R < 1$) or shortage ($R > 1$) of passivity.

For more information about the notion of passivity indices, see “About Passivity and Passivity Indices”.

`nu = getPassiveIndex(G, 'input')` computes the input passivity index. The system is input strictly passive when $nu > 0$. nu is also called the input feedforward passivity (IFP) index. The value of nu is the minimum feedforward action such that the resulting system is passive.

For more information about the notion of passivity indices, see “About Passivity and Passivity Indices”.

`rho = getPassiveIndex(G, 'output')` computes the output passivity index. The system is output strictly passive when $rho > 0$. rho is also called the output feedback passivity (OFP) index. The value of rho is the minimum feedback action such that the resulting system is passive.

For more information about the notion of passivity indices, see “About Passivity and Passivity Indices”.

`tau = getPassiveIndex(G, 'io')` computes the combined I/O passivity index. The system is very strictly passive when `tau > 0`.

For more information about the notion of passivity indices, see “About Passivity and Passivity Indices”.

`DX = getPassiveIndex(G, dQ)` computes the directional passivity index in the direction specified by the matrix `dQ`.

`index = getPassiveIndex(____, tol)` computes the passivity index with relative accuracy specified by `tol`. Use this syntax with any of the previous combinations of input arguments. `index` is the corresponding passivity index `R`, `nu`, `rho`, `tau`, or `DX`.

`index = getPassiveIndex(____, tol, fband)` computes passivity indices restricted to a specified frequency interval.

`[index, FI] = getPassiveIndex(____,)` also returns the frequency at which the returned index value is achieved.

`[index, FI, Qout, dQout] = getPassiveIndex(____,)` also returns the sector matrix `Qout` for passivity and the directional index matrix `dQout`.

Examples

Relative, Input, and Output Passivity Indices

Compute passivity indices for the following dynamic system:

$$G(s) = \frac{s^2 + s + 5s + 0.1}{s^3 + 2s^2 + 3s + 4}$$

```
G = tf([1,1,5, .1],[1,2,3,4]);
```

Compute the relative passivity index.

```
R = getPassiveIndex(G)
```

```
R = 0.9512
```

The system is passive, but with a relatively small excess of passivity.

Compute the input and output passivity indices.

```
nu = getPassiveIndex(G, 'input')
```

```
nu = 0.0250
```

```
rho = getPassiveIndex(G, 'output')
```

```
rho = 0.2583
```

This system is both input strictly passive and output strictly passive.

Compute the combined I/O passivity index.

```
tau = getPassiveIndex(G, 'io')
```

```
tau = 0.0250
```

The system is very strictly passive as well. A system that is very strictly passive is also strictly positive real. Examining the Nyquist plot confirms this, showing that the frequency response lies entirely within the right half-plane.

```
nyquistplot(G)
```

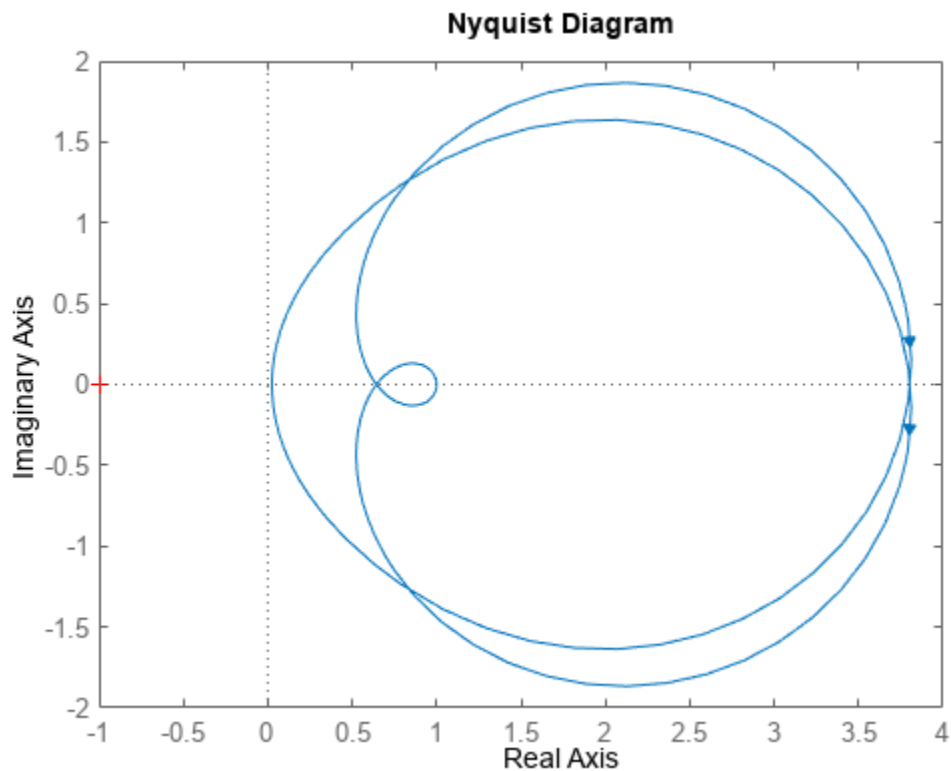

The relatively small τ value is reflected in how close the frequency response comes to the imaginary axis.

Relative Passivity Index and Frequency for Systems with Complex Coefficients

For systems with complex coefficients, `getPassiveIndex` can return indices at a negative or positive frequency depending on the `fband` you specify.

Load the state-space model with complex data.

```
load compCoeffModel.mat
```

Compute the relative passivity index and its frequency with a relative accuracy of 0.0001%. Also, specify `fband = [0.1, 1]` to compute the index in the frequency interval $[-1, -0.1] \cup [0.1, 1]$.

```
[R,FI] = getPassiveIndex(sys,1e-6,[0.1,1])
```

```
R = 3.0050
```

```
FI = -0.6518
```

In this interval, `sys` achieves a relative passivity index of 3.0050 at a negative frequency value of -0.6518 rad/s. Use `passiveplot` to plot the indices in this range.

```
opt = sectorplotoptions;
opt.FreqScale = 'Linear';
opt.IndexScale = 'Linear';
w = linspace(-1,1,100);
passiveplot(sys,w,opt)
```

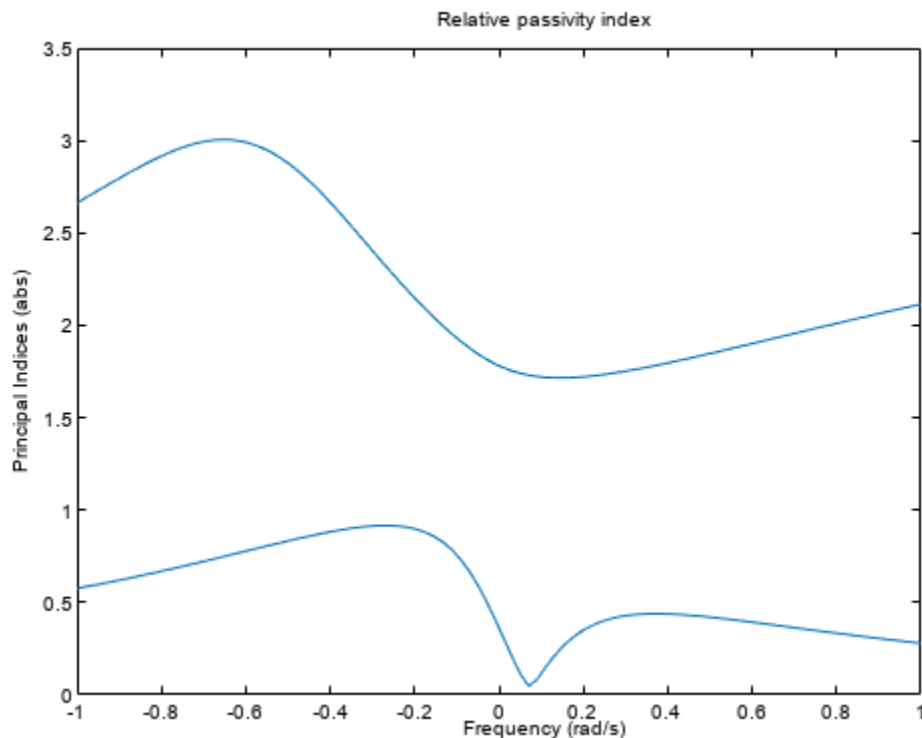

Now compute the relative passivity index in the frequency interval $[-10, -1.5] \cup [1.5, 10]$. To do so, specify `fband = [1.5, 10]`.

```
[R,FI] = getPassiveIndex(sys,1e-6,[1.5,10])
```

```
R = 2.4162
```

```
FI = 2.1707
```

In this interval, `sys` achieves a relative passivity index of 2.4162 at a positive frequency value of 2.1707 rad/s. Plot the indices in this range to confirm the result.

```
w = linspace(-10,10,1000);
passiveplot(sys,w,opt)
```

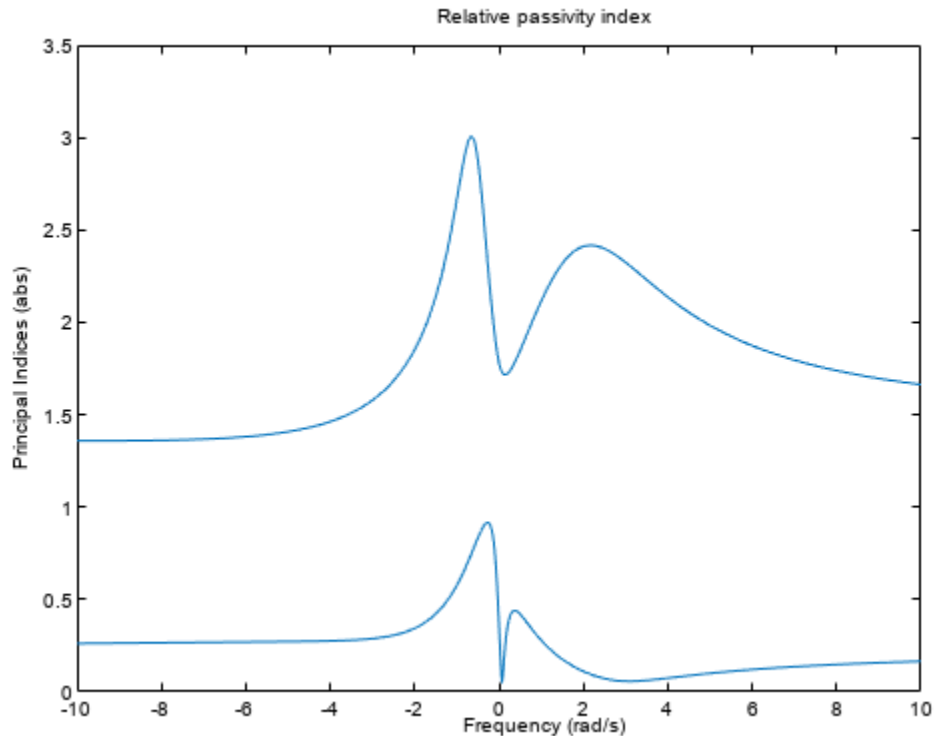

Input Arguments

G — Model to analyze

dynamic system model | model array

Model to analyze for passivity, specified as a dynamic system model such as a `tf`, `ss`, or `genss` model. `G` can be MIMO, if the number of inputs equals the number of outputs. `G` can be continuous or discrete. If `G` is a generalized model with tunable or uncertain blocks, `getPassiveIndex` evaluates passivity of the current, nominal value of `G`.

If `G` is a model array, then `getPassiveIndex` returns the passivity index as an array of the same size, where:

```
index(k) = getPassivityIndex(G(:,:,k),___)
```

Here, `index` is any of `R`, `nu`, `rho`, `tau`, or `DX`, depending on which input arguments you use.

dQ — Custom direction

matrix

Custom direction in which to compute passivity, specified as a symmetric square matrix that is $2 \times n_y$ on a side, where n_y is the number of outputs of `G`.

The rho, nu, and tau indices each correspond to a particular direction in the y/u space of the system, with a corresponding dQ value. (See dQout for these values.) Use this argument to specify your own value for this direction.

tol — Relative accuracy

0.01 (default) | positive real value

Relative accuracy for the calculated passivity index. By default, the tolerance is 1%, meaning that the returned passivity index is within 1% of the actual passivity index.

fband — Frequency interval

1-by-2 array

Frequency interval for determining passivity index, specified as an array of the form $[fmin, fmax]$ with $0 \leq fmin < fmax$. When you provide fband, then getPassiveIndex restricts the frequency-domain computation of the passivity index to that frequency range. For example, the relative passivity index R is the peak gain of the bilinear-transformed system $(I - G)(I + G)^{-1}$ (for minimum-phase $(I + G)$). When you provide fband, then R is the peak gain within the frequency band.

For models with complex coefficients, getPassiveIndex computes the passivity index in the range $[-fmax, -fmin] \cup [fmin, fmax]$. As a result, the function can return indices at a negative frequency.

Specify frequencies in units of rad/TimeUnit, where TimeUnit is the TimeUnit property of the dynamic system model G.

Output Arguments

R — Relative passivity index

scalar | array

Relative passivity index, returned as a scalar, or an array if G is an array.

The system G is passive when R is less than one.

- $R < 1$ indicates a relative excess of passivity.
- $R > 1$ indicates a relative shortage of passivity.

When $I + G$ is minimum phase, R is the peak gain of the bilinear-transformed system $(I - G)(I + G)^{-1}$.

For more information about the notion of passivity indices, see “About Passivity and Passivity Indices”.

nu — Input passivity index

scalar | array

Input passivity index, returned as a scalar, or an array if G is an array. nu is defined as the largest value of ν for which:

$$\int_0^T y(t)^T u(t) dt > \nu \int_0^T u(t)^T u(t) dt,$$

for all $T > 0$. Equivalently, nu is the largest ν for which:

$$G(j\omega) + G(j\omega)^H > 2\nu I$$

(or the discrete-time equivalent). The system is input strictly passive when $\nu > 0$. ν is also called the input feedforward passivity (IFP) index. The value of ν is the minimum feedforward action such that the resulting system is passive.

rho — Output passivity index

scalar | array

Output passivity index, returned as a scalar, or an array if G is an array. ρ is defined as the largest value of ρ for which:

$$\int_0^T y(t)^T u(t) dt > \rho \int_0^T y(t)^T y(t) dt,$$

for all $T > 0$. The system is output strictly passive when $\rho > 0$. ρ is also called the output feedback passivity (OFP) index. The value of ρ is the minimum feedback action such that the resulting system is passive.

tau — Combined I/O passivity index

scalar | array

Combined I/O passivity index, returned as a scalar, or an array if G is an array. τ is defined as the largest value of τ for which:

$$\int_0^T y(t)^T u(t) dt > \tau \int_0^T (u(t)^T u(t) + y(t)^T y(t)) dt,$$

for all $T > 0$. The system is very strictly passive when $\tau > 0$.

DX — Directional passivity index

scalar | array

Directional passivity index in the direction specified by dQ , returned as a scalar, or an array if G is an array. The directional passivity index is the largest value of D for which:

$$\int_0^T y(t)^T u(t) dt > D \int_0^T \begin{pmatrix} y(t) \\ u(t) \end{pmatrix}^T dQ \begin{pmatrix} y(t) \\ u(t) \end{pmatrix} dt,$$

for all $T > 0$. The ρ , ν , and τ indices correspond to particular choices of dQ (see the output argument `dQout`). To compute DX , the software uses the custom dQ value you supply, `dQ`.

FI — Frequency at which index is achieved

scalar | array

Frequency at which the returned passivity index is achieved, returned as a scalar, or an array if G is an array. In general, the passivity indices vary with frequency (see `passiveplot`). For each index type, the returned value is the largest value over all frequencies. FI is the frequency at which this value occurs, returned in units of rad/TimeUnit, where `TimeUnit` is the `TimeUnit` property of G .

FI can be negative for systems with complex coefficients.

Qout — Sector geometry

matrix

Sector geometry used for computing the passivity index, returned as a matrix. For passivity indices, $Qout$ is given by:

```
Qout = [zeros(ny), -1/2*eye(ny); -1/2*eye(ny), zeros(ny)];
```

where n_y is the number of outputs of G . For example, for a SISO G ,

```
Qout = [ 0, -0.5;
        -0.5, 0  ];
```

For more information about sector geometry, see `getSectorIndex`.

dQout — Direction

matrix

Direction in which passivity is computed, returned as a square matrix that is $2*n_y$ on a side, where n_y is the number of outputs of G . The value returned for `dQout` depends on what kind of passivity index you calculate:

- `nu` — For the input passivity index, `dQout` is given by:

```
dQout = [zeros(ny), zeros(ny); zeros(ny), eye(ny)];
```

 For instance, for a SISO system, `dQout = [0,0;0,1]`.
- `rho` — For the output passivity index, `dQout` is given by:

```
dQout = [eye(ny), zeros(ny); zeros(ny), zeros(ny)];
```

 For instance, for a SISO system, `dQout = [1,0;0,0]`.
- `tau` — For the combined I/O passivity index, `dQout` is given by:

```
dQout = eye(2*ny);
```

 For instance, for a SISO system, `dQout = [1,0;0,1]`.
- `DX` — `dQout` is the custom value you provide in the `dQ` input argument.
- `R` — The relative passivity index does not involve a direction, so in this case the function returns `dQout = []`.

For more information about directional indices, see `getSectorIndex`.

Limitations

- `getPassiveIndex(G, 'output')` might return incorrect results when one of the following conditions occurs:
 - G^{-1} is improper, that is, has infinite gain at $s = \text{Inf}$ or $z = \text{Inf}$.
 - G^{-1} has poles on the imaginary axis (for continuous-time G) or on the unit circle (for discrete-time G).

To circumvent this limitation, perturb G to have as many zeros as poles and only stable zeros. For example:

```
G = tf([1 0],[1 0.2 1]);
[rho,freq] = getPassiveIndex(G,'output') % returns incorrect answer

zpk(G+1e-4) % perturbed G is bi-proper and has stable zeros
[rho,freq] = getPassiveIndex(G+1e-4,'output') % returns expected answer
```

Version History

Introduced in R2016a

References

- [1] Xia, M., P. Gahinet, N. Abroug, C. Buhr, and E. Laroche. "Sector Bounds in Stability Analysis and Control Design." *International Journal of Robust and Nonlinear Control* 30, no. 18 (December 2020): 7857-82. <https://doi.org/10.1002/rnc.5236>.

See Also

`isPassive` | `passiveplot` | `getSectorIndex` | `getSectorCrossover` | `nyquist` | `sectorplot`

Topics

"Passivity Indices"

"About Passivity and Passivity Indices"

getPeakGain

Peak gain of dynamic system frequency response

Syntax

```
gpeak = getPeakGain(sys)
gpeak = getPeakGain(sys,tol)
gpeak = getPeakGain(sys,tol,fband)
[gpeak,fpeak] = getPeakGain( ___ )
```

Description

`gpeak = getPeakGain(sys)` returns the peak input/output gain in absolute units of the dynamic system model, `sys`.

- If `sys` is a SISO model, then the peak gain is the largest value of the frequency response magnitude.
- If `sys` is a MIMO model, then the peak gain is the largest value of the frequency response 2-norm (the largest singular value across frequency) of `sys`. This quantity is also called the L_∞ norm of `sys`, and coincides with the H_∞ norm for stable systems (see `norm`).
- If `sys` is a model that has tunable or uncertain parameters, `getPeakGain` evaluates the peak gain at the current or nominal value of `sys`.
- If `sys` is a model array, `getPeakGain` returns an array of the same size as `sys`, where `gpeak(k) = getPeakGain(sys(:, :, k))`.

`gpeak = getPeakGain(sys,tol)` returns the peak gain of `sys` with relative accuracy `tol`.

`gpeak = getPeakGain(sys,tol,fband)` returns the peak gain in the frequency interval `fband = [fmin,fmax]` with $0 \leq fmin < fmax$. This syntax also takes into account the negative frequencies in the band `[-fmax,-fmin]` for models with complex coefficients.

`[gpeak,fpeak] = getPeakGain(___)` also returns the frequency `fpeak` at which the gain achieves the peak value `gpeak`, and can include any of the input arguments in previous syntaxes. `fpeak` can be negative for systems with complex coefficients.

Examples

Peak Gain of Transfer Function

Compute the peak gain of the resonance in the following transfer function:

$$\text{sys} = \frac{90}{s^2 + 1.5s + 90}$$

```
sys = tf(90,[1,1.5,90]);
gpeak = getPeakGain(sys)
```

```
gpeak = 6.3444
```

The `getPeakGain` command returns the peak gain in absolute units.

Peak Gain with Specified Accuracy

Compute the peak gain of the resonance in the transfer function with a relative accuracy of 0.01%.

$$\text{sys} = \frac{90}{s^2 + 1.5s + 90}.$$

```
sys = tf(90,[1,1.5,90]);
gpeak = getPeakGain(sys,0.0001)
```

```
gpeak = 6.3444
```

The second argument specifies a relative accuracy of 0.0001. The `getPeakGain` command returns a value that is within 0.0001 (0.01%) of the true peak gain of the transfer function. By default, the relative accuracy is 0.01 (1%).

Peak Gain Within Specified Band

Compute the peak gain of the higher-frequency resonance in the transfer function

$$\text{sys} = \left(\frac{1}{s^2 + 0.2s + 1} \right) \left(\frac{100}{s^2 + s + 100} \right).$$

`sys` is the product of resonances at 1 rad/s and 10 rad/s.

```
sys = tf(1,[1,.2,1])*tf(100,[1,1,100]);
fband = [8,12];
gpeak = getPeakGain(sys,0.01,fband);
```

The `fband` argument causes `getPeakGain` to return the local peak gain between 8 and 12 rad/s.

Frequency of Peak Gain

Identify which of the two resonances has higher gain in the transfer function

$$\text{sys} = \left(\frac{1}{s^2 + 0.2s + 1} \right) \left(\frac{100}{s^2 + s + 100} \right).$$

`sys` is the product of resonances at 1 rad/s and 10 rad/s.

```
sys = tf(1,[1,.2,1])*tf(100,[1,1,100]);
[gpeak,fpeak] = getPeakGain(sys)
```

```
gpeak = 5.0747
```

```
fpeak = 0.9902
```

`fPeak` is the frequency corresponding to the peak gain `gPeak`. The peak at 1 rad/s is the overall peak gain of `sys`.

Frequency of Peak Gain for System with Complex Coefficients

For systems with complex coefficients, `getPeakGain` can return a peak at a negative or positive frequency depending on the shape and `fband` you specify.

Generate a random state-space model with complex data.

```
rng(1)
A = complex(randn(10),randn(10));
B = complex(randn(10,3),randn(10,3));
C = complex(randn(2,10),randn(2,10));
D = complex(randn(2,3),randn(2,3));
sys = ss(A,B,C,D);
```

Compute the peak gain with a relative accuracy of 0.1%. Also, specify `fband = [0,1]` to compute the peak in the frequency interval `[-1,1]`.

```
[gPeak, fPeak] = getPeakGain(sys, 1e-3, [0,1])
```

```
gPeak = 126.2396
```

```
fPeak = -0.4579
```

In this interval, `sys` attains a peak at a negative frequency value. Create a singular value plot in this range to confirm the result.

```
w = linspace(-1,1,100);
opt = sigmaoptions;
opt.FreqScale = 'Linear';
opt.MagUnits = 'abs';
sigmaplot(sys,w,opt)
```

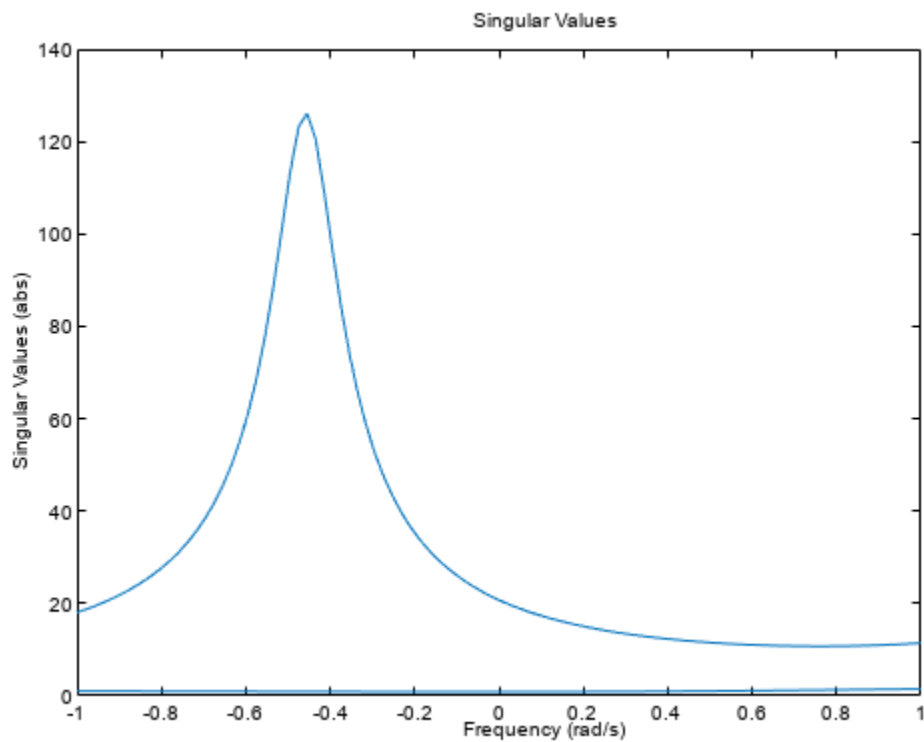

Now compute the peak gain in the frequency interval $[-50,-1] \cup [1,50]$. To do so, specify `fband = [1, 50]`.

```
[gPeak, fPeak] = getPeakGain(sys, 1e-3, [1, 50])
```

```
gPeak = 43.3303
```

```
fPeak = 1.8097
```

In this interval, `sys` attains a peak at a positive frequency value.

Create a singular value plot in this range to confirm the result.

```
w = linspace(-50, 50, 5000);  
sigmaplot(sys, w, opt)
```

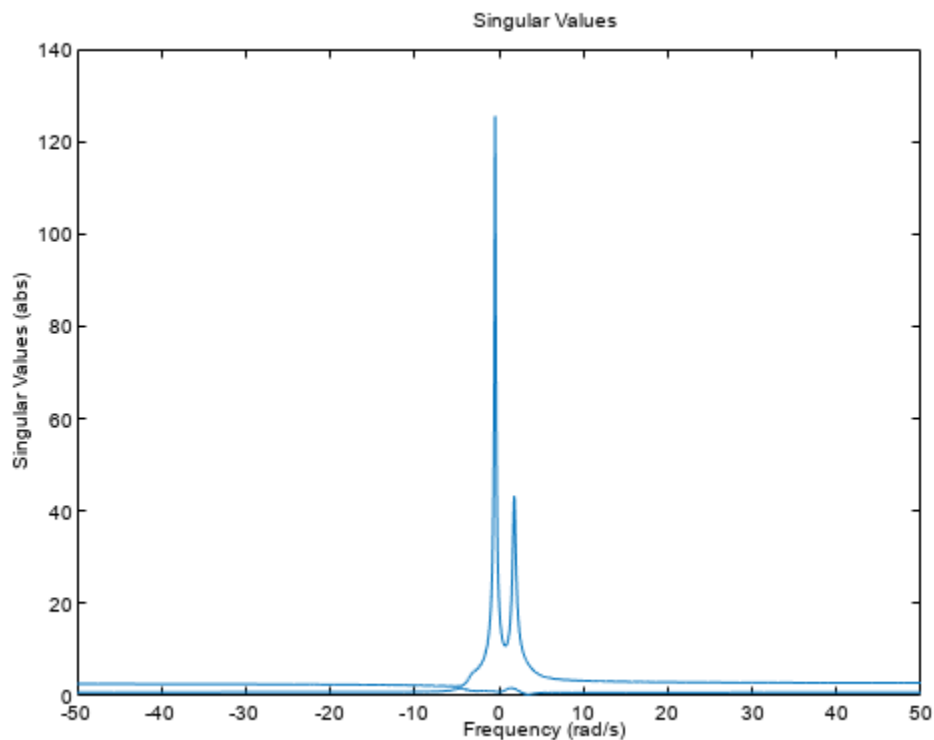

For this interval, `getPeakGain` returns the magnitude and frequency value for the smaller peak shown in the plot.

Input Arguments

sys — Input dynamic system

dynamic system model | model array

Input dynamic system, specified as any dynamic system model or model array. `sys` can be SISO or MIMO.

tol — Relative accuracy

0.01 (default) | positive real scalar

Relative accuracy of the peak gain, specified as a positive real scalar value. `getPeakGain` calculates `gpeak` such that the fractional difference between `gpeak` and the true peak gain of `sys` is no greater than `tol`. The default value is 0.01, meaning that `gpeak` is within 1% of the true peak gain.

fband — Frequency interval

[0, Inf] (default) | 1-by-2 vector of positive real values

Frequency interval in which to calculate the peak gain, specified as a 1-by-2 vector of positive real values. Specify `fband` as a row vector of the form `[fmin, fmax]` with $0 \leq fmin < fmax$.

For models with complex coefficients, `getPeakGain` calculates the peak gain in the range $[-f_{\max}, -f_{\min}] \cup [f_{\min}, f_{\max}]$. As a result, the function can return a peak at a negative frequency.

Output Arguments

gpeak — Peak gain of dynamic system

scalar | array

Peak gain of the dynamic system model or model array `sys`, returned as a scalar value or an array.

- If `sys` is a single model, then `gpeak` is a scalar value.
- If `sys` is a model array, then `gpeak` is an array of the same size as `sys`, where `gpeak(k) = getPeakGain(sys(:, :, k))`.

fpeak — Frequency of peak gain

real scalar | array of real values

Frequency at which the gain achieves the peak value `gpeak`, returned as a real scalar value or an array of real values. The frequency is expressed in units of rad/TimeUnit, relative to the `TimeUnit` property of `sys`.

- If `sys` is a single model, then `fpeak` is a scalar.
- If `sys` is a model array, then `fpeak` is an array of the same size as `sys`, where `fpeak(k)` is the peak gain frequency of `sys(:, :, k)`.

`fpeak` can be negative for systems with complex coefficients.

Algorithms

`getPeakGain` uses the algorithm of [1]. All eigenvalue computations are performed using structure-preserving algorithms from the SLICOT library. For more information about the SLICOT library, see <http://slicot.org>.

Version History

Introduced in R2012a

References

- [1] Bruinsma, N.A., and M. Steinbuch. "A Fast Algorithm to Compute the H_{∞} Norm of a Transfer Function Matrix." *Systems & Control Letters*, 14, no.4 (April 1990): 287–93.

See Also

`freqresp` | `bode` | `sigma` | `getGainCrossover` | `norm` | `hinfnorm`

Topics

"Dynamic System Models"

getPIDLoopResponse

Closed-loop and open-loop responses of systems with PID controllers

Syntax

```
response = getPIDLoopResponse(C,G,looptype)
```

Description

`response = getPIDLoopResponse(C,G,looptype)` returns a response of the control loop formed by the PID controller C and the plant G . The function returns the closed-loop, open-loop, controller action, or disturbance response that you specify with the `looptype` argument. The function assumes the following control architecture.

- When C is a `pid` or `pidstd` controller object (1-DOF controller):

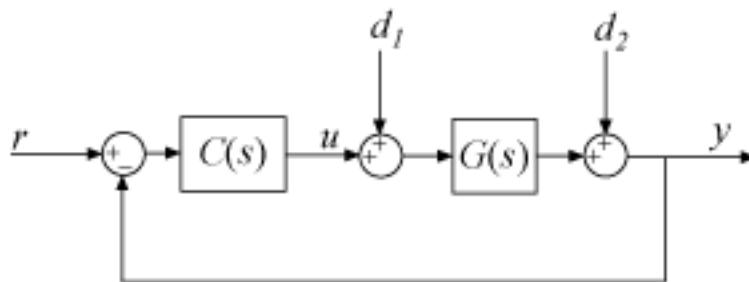

- When C is a `pid2` or `pidstd2` controller object (2-DOF controller):

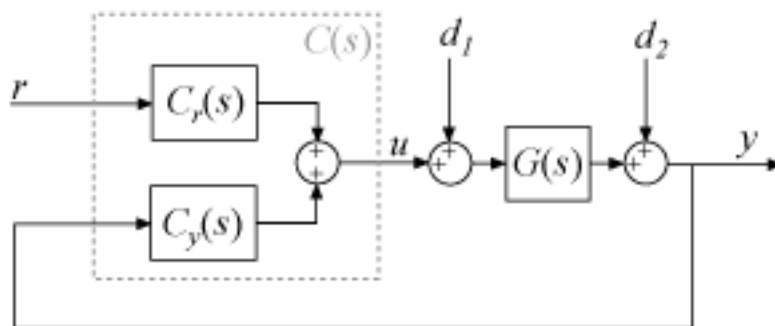

Examples

Validate Controller Performance by Examining Closed-Loop Responses

Design a PI controller for a SISO plant and examine its performance in reference tracking and disturbance rejection. For reference tracking, use the "closed-loop" response. For rejection of a load disturbance, use "input-disturbance".

```
G = tf(1,[1 1 1]);
C = pidtune(G,'PI');
Tref = getPIDLoopResponse(C,G,"closed-loop");
Tdist = getPIDLoopResponse(C,G,"input-disturbance");
step(Tref,Tdist)
legend("Reference Tracking","Disturbance Rejection")
```

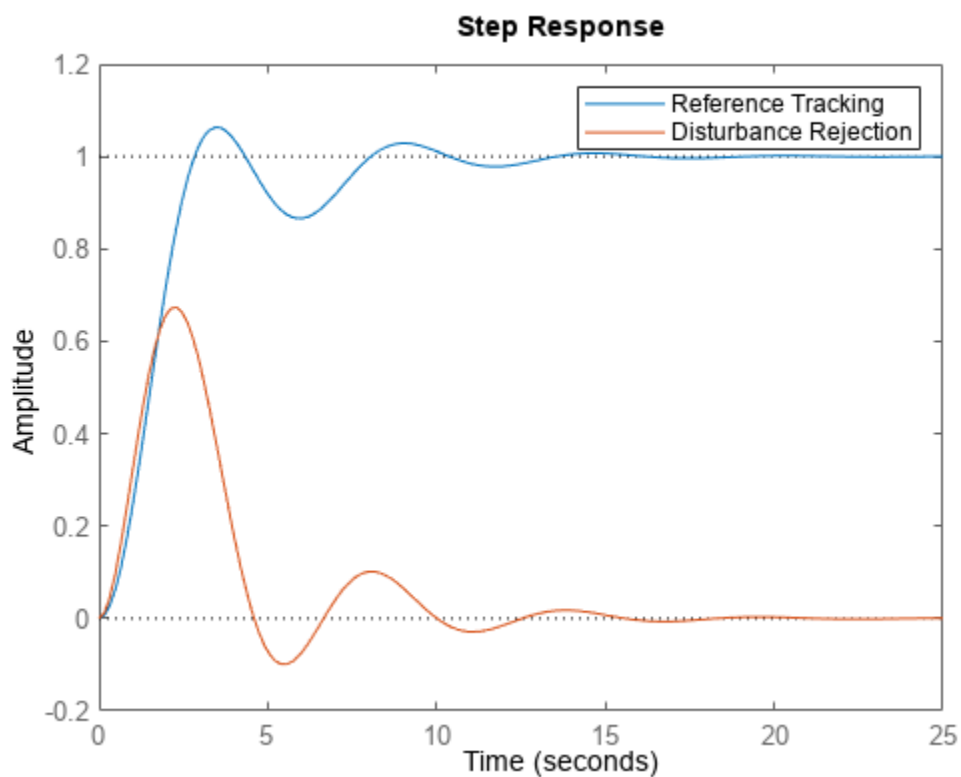

Validate the tuned controller by comparing the extracted responses to your design requirements for settling time and overshoot.

Responses of System with 2-DOF PID Controller

Design a two-degree-of-freedom (2-DOF) PID controller for a plant and examine its performance in reference tracking and disturbance rejection. For reference tracking, use the "closed-loop" response. For rejection of a load disturbance, use "input-disturbance".

```
G = tf(1,[1 0.5 0.1]);
w0 = 1.5;
```

```

C = pidtune(G, 'PID2', w0);
Tref = getPIDLoopResponse(C, G, "closed-loop");
Tdist = getPIDLoopResponse(C, G, "input-disturbance");
step(Tref, Tdist)
legend("Reference Tracking", "Disturbance Rejection")

```

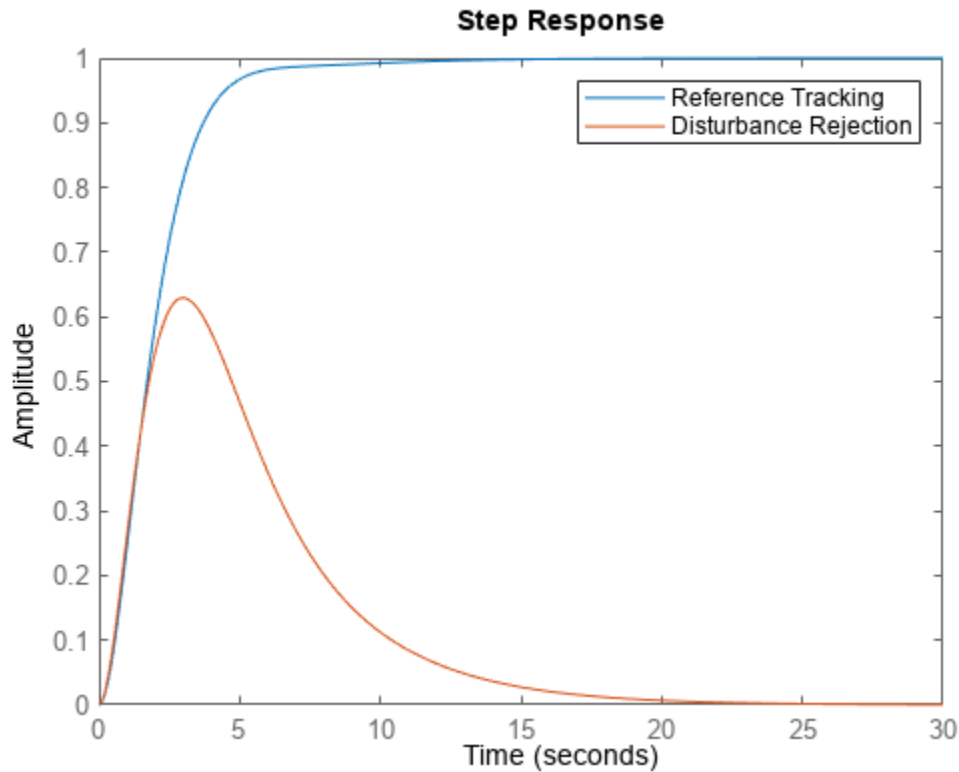

Input Arguments

C — PID controller

PID controller object

PID controller, specified as a PID controller object (`pid`, `pidstd`, `pid2`, or `pidstd2`).

G — Plant

dynamic system model

Plant, specified as a SISO dynamic system model, such as a `tf`, `ss`, `zpk`, or `frd` model object. If `G` is a model with tunable or uncertain elements (such as a `genss` or `uss` model), then the function uses the current or nominal value of the model.

looptype — Loop response to return

string | character vector

Loop response to return, specified as a string or character vector. The available loop responses are given in the following table.

Response	1-DOF Controller	2-DOF Controller	Description
"open-loop"	GC	$-GC_y$	Response of the open-loop controller-plant system. Use for frequency-domain design. Use when your design specifications include robustness criteria such as open-loop gain margin and phase margin.
"closed-loop"	$\frac{GC}{1+GC}$ (from r to y)	$\frac{GC_r}{1-GC_y}$ (from r to y)	Closed-loop system response to a step change in setpoint. Use when your design specifications include setpoint tracking.
"controller-effort"	$\frac{C}{1+GC}$ (from r to u)	$\frac{C_r}{1-GC_y}$ (from r to u)	Closed-loop controller output response to a step change in setpoint. Use when your design is limited by practical constraints, such as controller saturation.
"input-disturbance"	$\frac{G}{1+GC}$ (from d_1 to y)	$\frac{G}{1-GC_y}$ (from d_1 to y)	Closed-loop system response to load disturbance (a step disturbance at the plant input). Use when your design specifications include input disturbance rejection.
"output-disturbance"	$\frac{1}{1+GC}$ (from d_2 to y)	$\frac{1}{1-GC_y}$ (from d_2 to y)	Closed-loop system response to a step disturbance at plant output. Use when you want to analyze sensitivity to modeling errors.

Output Arguments

response — Selected loop response

ss model | frd model

Selected loop response, returned as a state-space (ss) or frequency-response data (frd) model. If G is an frd model, then response is also an frd model with the same frequencies as G . Otherwise, response is an ss model.

Version History

Introduced in R2019a

See Also

pid | pidstd | pid2 | pidstd2 | pidtune

getPoints

Get list of analysis points in generalized model of control system

Syntax

```
points = getPoints(T)
```

Description

`points = getPoints(T)` returns the names of all analysis-point locations in a generalized state-space model of a control system. Use this function to query the list of available analysis points in the model for control system analysis or tuning. You can refer to the analysis-point locations by name to create design goals control system tuning or to compute open-loop and closed-loop responses using analysis commands such as `getLoopTransfer` and `getIOTransfer`.

Examples

Analysis-Point Locations in Control System Model

Build a closed-loop model of a cascaded feedback loop system, and get a list of analysis point locations in the model.

Create a model of the following cascaded feedback loop. C_1 and C_2 are tunable controllers. AP_1 and AP_2 are points of interest for analysis, which you mark with `AnalysisPoint` blocks.

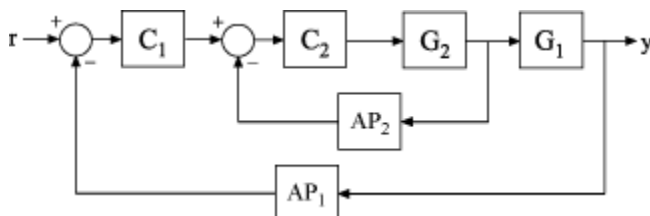

```
G1 = tf(10,[1 10]);
G2 = tf([1 2],[1 0.2 10]);
C1 = tunablePID('C','pi');
C2 = tunableGain('G',1);
AP1 = AnalysisPoint('AP1');
AP2 = AnalysisPoint('AP2');
T = feedback(G1*feedback(G2*C2,AP2)*C1,AP1);
```

T is a `genss` model whose Control Design Blocks include the tunable controllers and the switches `AP1` and `AP2`.

Get a list of the loop-opening sites in T.

```
points = getPoints(T)
```

```
points = 2x1 cell
    {'AP1'}
```

```
{ 'AP2' }
```

`getPoints` returns a cell array listing loop-opening sites in the model.

For more complicated closed-loop models, you can use `getPoints` to keep track of a larger number of analysis points.

Input Arguments

T — Model of control system

generalized state-space model

Model of a control system, specified as a generalized state-space (`genss`) model. Locations in the model at which you can calculate system responses or specify design goals for tuning are marked by `AnalysisPoint` blocks in `T`.

Output Arguments

points — Analysis-point locations

cell array of character vectors

Analysis-point locations in the control system model, returned as a cell array of character vectors. This output is obtained by concatenating the `Location` properties of all `AnalysisPoint` blocks in the control system model.

Version History

Introduced in R2014b

See Also

`AnalysisPoint` | `genss` | `getLoopTransfer` | `getIOTransfer`

Topics

“Generalized Models”

getSectorCrossover

Crossover frequencies for sector bound

Syntax

```
wc = getSectorCrossover(H,Q)
```

Description

`wc = getSectorCrossover(H,Q)` returns the frequencies at which the following matrix $M(\omega)$ is singular:

$$M(\omega) = H(j\omega)^H Q H(j\omega).$$

When a frequency-domain sector plot exists, these frequencies are the frequencies at which the relative sector index (R-index) for H and Q equals 1. See “About Sector Bounds and Sector Indices” for details.

Examples

Find Sector Crossover Frequency

Find the crossover frequencies for the dynamic system $G(s) = (s + 2)/(s + 1)$ and the sector defined by:

$$S = \{(y, u) : au^2 < uy < bu^2\},$$

for various values of a and b .

In U/Y space, this sector is the shaded region of the following diagram (for $a, b > 0$).

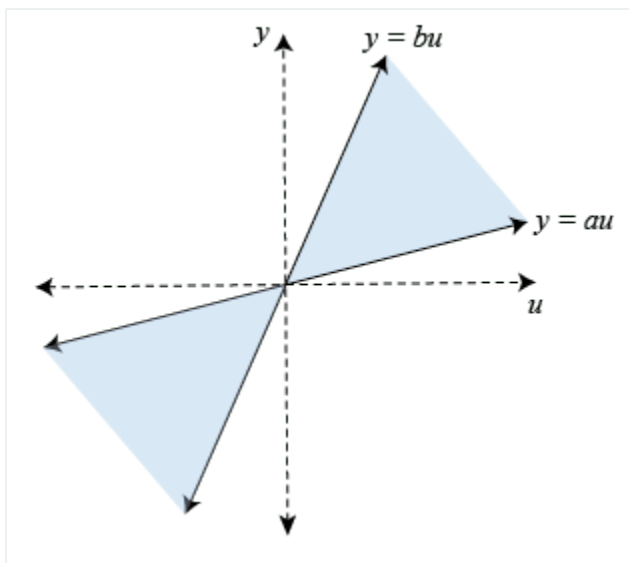

The Q matrix for this sector is given by:

$$Q = \begin{bmatrix} 1 & -(a+b)/2 \\ -(a+b)/2 & ab \end{bmatrix}; \quad a = 0.1, b = 10.$$

`getSectorCrossover` finds the frequencies at which $H(s)^H Q H(s)$ is singular, for $H(s) = [G(s); I]$. For instance, find these frequencies for the sector defined by Q with $a = 0.1$ and $b = 10$.

```
G = tf([1 2],[1 1]);
H = [G;1];

a = 0.1;
b = 10;
Q = [1 -(a+b)/2 ; -(a+b)/2 a*b];

w = getSectorCrossover(H,Q)

w =

    0x1 empty double column vector
```

The empty result means that there are no such frequencies.

Now find the frequencies at which $H^H Q H$ is singular for a narrower sector, with $a = 0.5$ and $b = 1.5$.

```
a2 = 0.5;
b2 = 1.5;
Q2 = [1 -(a2+b2)/2 ; -(a2+b2)/2 a2*b2];

w2 = getSectorCrossover(H,Q2)

w2 = 1.7321
```

Here the resulting frequency is where the R-index for H and Q2 is equal to 1, as shown in the sector plot.

```
sectorplot(H,Q2)
```

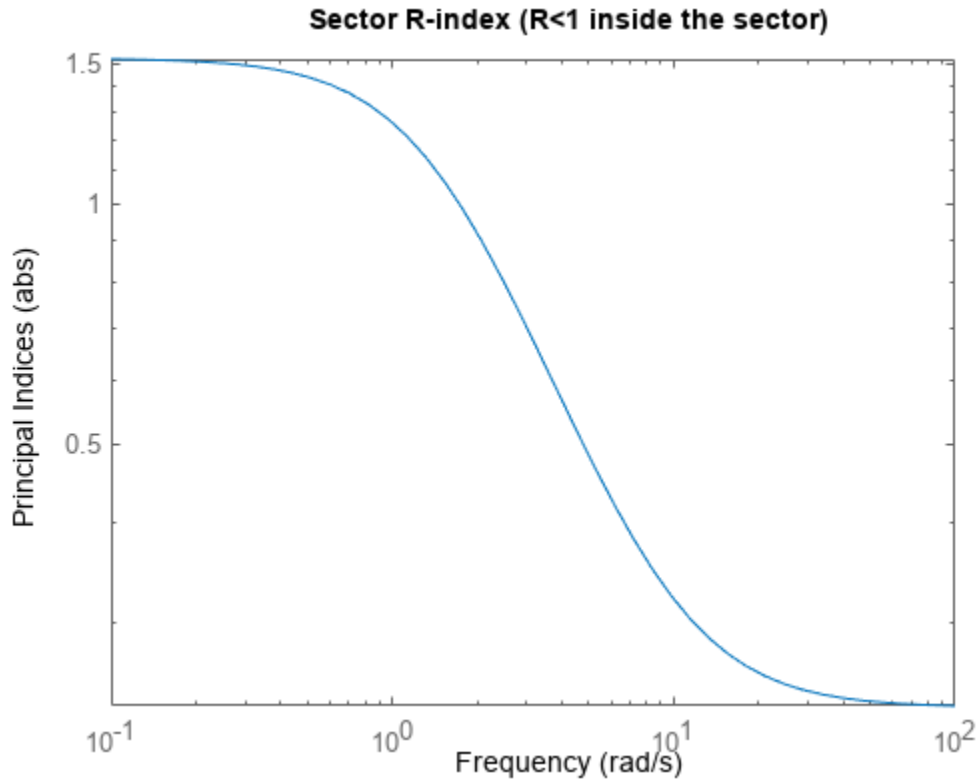

Thus, when a sector plot exists for a system H and sector Q , `getSectorCrossover` finds the frequencies at which the R-index is 1.

Input Arguments

H — Model to analyze

dynamic system model

Model to analyze against sector bounds, specified as a dynamic system model such as a `tf`, `ss`, or `genss` model. H can be continuous or discrete. If H is a generalized model with tunable or uncertain blocks, `getSectorCrossover` analyzes the current, nominal value of H .

To get the frequencies at which the I/O trajectories (u, y) of a linear system G lie in a particular sector, use $H = [G; I]$, where $I = \text{eyes}(nu)$, and nu is the number of inputs of G .

Q — Sector geometry

matrix | LTI model

Sector geometry, specified as:

- A matrix, for constant sector geometry. Q is a symmetric square matrix that is ny on a side, where ny is the number of outputs of H .
- An LTI model, for frequency-dependent sector geometry. Q satisfies $Q(s)' = Q(-s)$. In other words, $Q(s)$ evaluates to a Hermitian matrix at each frequency.

The matrix Q must be indefinite to describe a well-defined conic sector. An indefinite matrix has both positive and negative eigenvalues.

For more information, see “About Sector Bounds and Sector Indices”.

Output Arguments

wc — Sector crossover frequencies

vector | []

Sector crossover frequencies, returned as a vector. The frequencies are expressed in rad/TimeUnit, relative to the TimeUnit property of H. If the trajectories of H never cross the boundary, wc = [].

Version History

Introduced in R2016a

See Also

getSectorIndex | getGainCrossover | sectorplot

Topics

“About Sector Bounds and Sector Indices”

getSectorIndex

Compute conic-sector index of linear system

Syntax

```
RX = getSectorIndex(H,Q)
RX = getSectorIndex(H,Q,tol)
RX = getSectorIndex(H,Q,tol,fband)
[RX,FX] = getSectorIndex(____)
[RX,FX,W1,W2,Z] = getSectorIndex(____)
```

```
DX = getSectorIndex(H,Q,dQ)
DX = getSectorIndex(H,Q,dQ,tol)
```

Description

`RX = getSectorIndex(H,Q)` computes the relative index `RX` for the linear system `H` and the conic sector specified by `Q`. When `RX < 1`, all output trajectories $y(t) = Hu(t)$ lie in the sector defined by:

$$\int_0^T y(t)^T Q y(t) dt < 0,$$

for all $T \geq 0$.

`getSectorIndex` can also check whether all I/O trajectories $\{u(t),y(t)\}$ of a linear system `G` lie in the sector defined by:

$$\int_0^T \begin{pmatrix} y(t) \\ u(t) \end{pmatrix}^T Q \begin{pmatrix} y(t) \\ u(t) \end{pmatrix} dt < 0,$$

for all $T \geq 0$. To do so, use `getSectorIndex` with `H = [G;I]`, where `I = eyes(nu)`, and `nu` is the number of inputs of `G`.

For more information about sector bounds and the relative index, see “About Sector Bounds and Sector Indices”.

`RX = getSectorIndex(H,Q,tol)` computes the index with relative accuracy specified by `tol`.

`RX = getSectorIndex(H,Q,tol,fband)` computes the passivity index by restricting the inequalities that define the index to a specified frequency interval. This syntax is available only when `Q` has as many negative eigenvalues as there are inputs in `H`.

`[RX,FX] = getSectorIndex(____)` also returns the frequency `FX` at which the index value `RX` is achieved. `FX` is set to `NaN` when the number of negative eigenvalues in `Q` differs from the number of inputs in `H`. You can use this syntax with any of the previous combinations of input arguments.

`[RX,FX,W1,W2,Z] = getSectorIndex(____)` also returns the decomposition of `Q` into its positive and negative parts, as well as the spectral factor `Z` when `Q` is dynamic. When `Q` is a matrix (constant sector bounds), `Z = 1`. You can use this syntax with any of the previous combinations of input arguments.

$DX = \text{getSectorIndex}(H, Q, dQ)$ computes the index in the direction specified by the matrix dQ . If $DX > 0$, then the output trajectories of H fit in the conic sector specified by Q . For more information about the directional index, see "About Sector Bounds and Sector Indices".

The directional index is not available if H is a frequency-response data (frd) model.

$DX = \text{getSectorIndex}(H, Q, dQ, tol)$ computes the index with relative accuracy specified by tol .

Examples

Check Sector Bounds

Test whether, on average, the I/O trajectories of $G(s) = (s + 2)/(s + 1)$ belong within the sector defined by:

$$S = \{(y, u) : 0.1u^2 < uy < 10u^2\}.$$

In U/Y space, this sector is the shaded region of the following diagram.

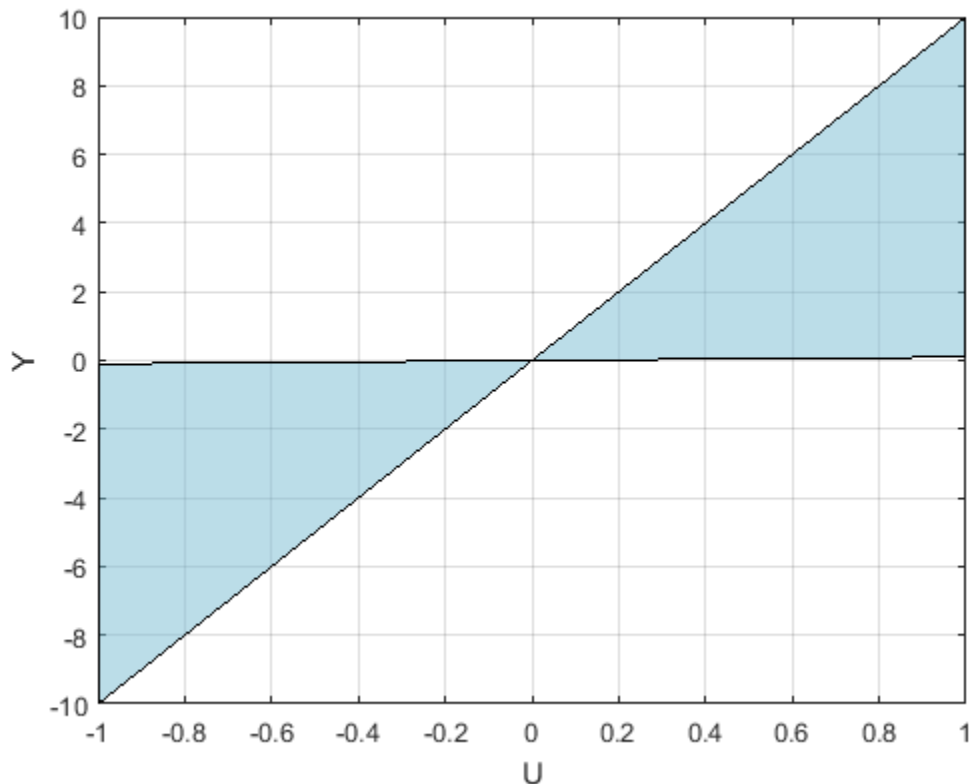

The Q matrix corresponding to this sector is given by:

$$Q = \begin{bmatrix} 1 & -(a+b)/2 \\ -(a+b)/2 & ab \end{bmatrix}; \quad a = 0.1, \quad b = 10.$$

A trajectory $y(t) = Gu(t)$ lies within the sector S when for all $T > 0$,

$$0.1 \int^T u(t)^2 < \int^T u(t)y(t)dt < 10 \int^T u(t)^2 dt.$$

To check whether trajectories of G satisfy the sector bound, represented by Q , compute the R -index for $H = [G; 1]$.

```
G = tf([1 2],[1 1]);
a = 0.1; b = 10;
Q = [1 -(a+b)/2 ; -(a+b)/2 a*b];
R = getSectorIndex([G;1],Q)
R = 0.4074
```

This resulting R is less than 1, indicating that the trajectories fit within the sector. The value of R tells you how much tightly the trajectories fit in the sector. This value, $R = 0.41$, means that the trajectories would fit in a narrower sector with a base $1/0.41 = 2.4$ times smaller.

R-Index in Frequency Band for System with Complex Coefficients

For systems with complex coefficients, `getSectorIndex` can return indices at a negative or a positive frequency depending on the `fband` you specify.

Load a state-space model with complex coefficients and complex sector matrix.

```
load dataSysQ sys Q
```

Compute the R -index and its frequency with a relative accuracy of 0.0001%. Also, specify `fband = [1, 10]` to compute the index in the frequency interval $[-10, -1] \cup [1, 10]$.

```
[R,FX] = getSectorIndex(sys,Q,1e-6,[1,10])
R = 1.5811
FX = -7.2320
```

In this interval, `sys` achieves an index of 1.5811 at a negative frequency value of -7.2320 rad/s. Use `sectorplot` to plot the indices in this range.

```
opt = sectorplotoptions;
opt.FreqScale = 'Linear';
opt.IndexScale = 'Linear';
w = linspace(-10,10,1000);
sectorplot(sys,Q,w,opt)
```

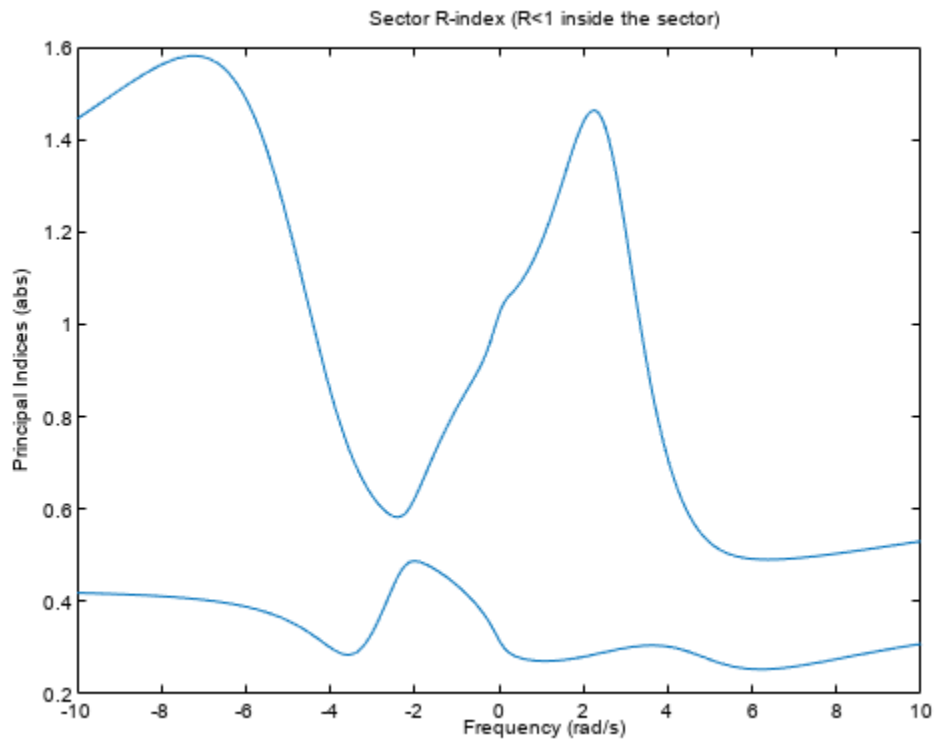

Now compute the index in the frequency interval $[-5,-1] \cup [1,5]$. To do so, specify `fband = [1, 5]`.

```
[r, f] = getSectorIndex(sys, 0, 1e-6, [1, 5])
```

```
r = 1.4630
```

```
f = 2.2499
```

In this interval, `sys` achieves an index of 1.4630 at a positive frequency value of 2.2499 rad/s. Plot the indices in this range to confirm the result.

```
w = linspace(-5, 5, 500);
sectorplot(sys, 0, w, opt)
```

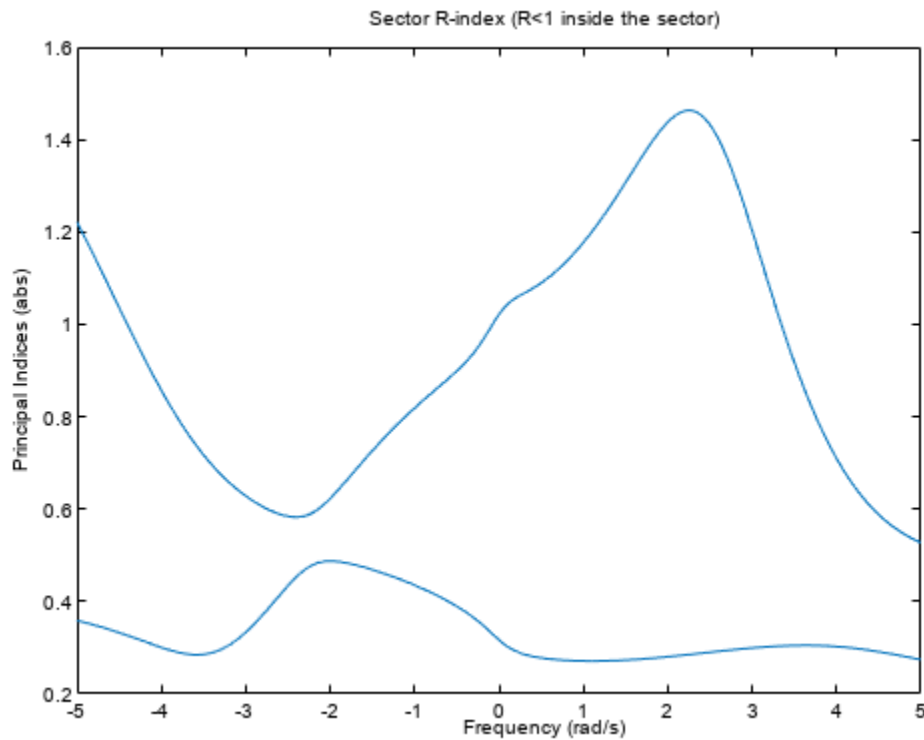

Input Arguments

H — Model to analyze

dynamic system model | model array

Model to analyze against sector bounds, specified as a dynamic system model such as a `tf`, `ss`, or `genss` model. `H` can be continuous or discrete. If `H` is a generalized model with tunable or uncertain blocks, `getSectorIndex` analyzes the current, nominal value of `H`.

To analyze whether all I/O trajectories $\{u(t), y(t)\}$ of a linear system G lie in a particular sector, use $H = [G; I]$.

If `H` is a model array, then `getSectorIndex` returns the passivity index as an array of the same size, where:

```
index(k) = getSectorIndex(H(:, :, k), ___)
```

Here, `index` is either `RX`, or `DX`, depending on which input arguments you use.

Q — Sector geometry

matrix | LTI model

Sector geometry, specified as:

- A matrix, for constant sector geometry. `Q` is a symmetric square matrix that is `ny` on a side, where `ny` is the number of outputs of `H`.

- An LTI model, for frequency-dependent sector geometry. Q satisfies $Q(s)' = Q(-s)$. In other words, $Q(s)$ evaluates to a Hermitian matrix at each frequency.

The matrix Q must be indefinite to describe a well-defined conic sector. An indefinite matrix has both positive and negative eigenvalues.

For more information, see “About Sector Bounds and Sector Indices”.

tol — Relative accuracy

0.01 (default) | positive real value

Relative accuracy for the calculated sector index. By default, the tolerance is 1%, meaning that the returned index is within 1% of the actual index.

fband — Frequency interval

1-by-2 array

Frequency interval for calculating the sector index, specified as an array of the form $[fmin, fmax]$ with $0 \leq fmin < fmax$. When you provide **fband**, `getSectorIndex` restricts to the specified frequency interval the inequalities that define the index.

For models with complex coefficients, `getSectorIndex` computes the index in the range $[-fmax, -fmin] \cup [fmin, fmax]$. As a result, the function can return indices at a negative frequency.

Specify frequencies in units of $\text{rad}/\text{TimeUnit}$, where `TimeUnit` is the `TimeUnit` property of the dynamic system model H .

dQ — Direction

matrix

Direction in which to compute directional sector index, specified as a nonnegative definite matrix. The matrix dQ is a symmetric square matrix that is ny on a side, where ny is the number of outputs of H .

Output Arguments

RX — Relative sector index

scalar | array

Relative index of the system H for the sector specified by Q , returned as a scalar value, or an array if H is an array. If $RX < 1$, then the output trajectories of H fit inside the cone of Q .

The value of RX provides a measure of how tightly the output trajectories of H fit inside the cone. Let the following be an orthogonal decomposition of the symmetric matrix Q into its positive and negative parts.

$$Q = W_1 W_1^T - W_2 W_2^T, \quad W_1^T W_2 = 0.$$

(Such a decomposition is readily obtained from the Schur decomposition of Q .) Then, RX is the smallest R that satisfies:

$$\int_0^T y(t)^T (W_1 W_1^T - R^2 W_2 W_2^T) y(t) dt < 0,$$

for all $T \geq 0$. Varying R is equivalent to adjusting the slant angle of the cone specified by Q until the cone fits tightly around the output trajectories of H . The cone base-to-height ratio is proportional to R .

For more information about interpretations of the relative index, see “About Sector Bounds and Sector Indices”.

FX — Frequency at which index is achieved

scalar | array

Frequency at which the index RX is achieved, returned as a scalar, or an array if H is an array. In general, the index varies with frequency (see `sectorplot`). The returned value is the largest value over all frequencies. FX is the frequency at which this value occurs, returned in units of $\text{rad}/\text{TimeUnit}$, where TimeUnit is the TimeUnit property of H .

FX can be negative for systems with complex coefficients.

W1, W2 — Positive and negative factors of Q

matrices

Positive and negative factors of Q , returned as matrices. For a constant Q , $W1$ and $W2$ satisfy:

$$Q = W_1 W_1^T - W_2 W_2^T, \quad W_1^T W_2 = 0.$$

Z — Bistable model

state-space model | 1

Bistable model in the factorization of Q , returned as:

- If Q is a constant matrix, $Z = 1$.
- If Q is frequency-dependent, then Z is a state-space (ss) model such that:

$$Q(j\omega) = Z(j\omega)^H (W_1 W_1^T - W_2 W_2^T) Z(j\omega).$$

DX — Directional sector index

scalar | array

Directional sector index of the system H for the sector specified by Q in the direction dQ , returned as a scalar value, or an array if H is an array. The directional index is the largest τ which satisfies:

$$\int_0^T y(t)^T (Q + \tau dQ) y(t) dt < 0,$$

for all $T \geq 0$.

Version History

Introduced in R2016a

See Also

`getSectorCrossover` | `getPassiveIndex` | `getPeakGain` | `nyquist` | `sectorplot`

Topics

“About Sector Bounds and Sector Indices”

getSensitivity

Sensitivity function from generalized model of control system

Syntax

```
S = getSensitivity(T,location)
S = getSensitivity(T,location,opening)
```

Description

`S = getSensitivity(T,location)` returns the sensitivity function on page 2-448 at the specified location for a generalized model of a control system.

`S = getSensitivity(T,location,opening)` specifies additional loop openings for the sensitivity function calculation. Use an opening, for example, to calculate the sensitivity function of an inner loop, with the outer loop open.

If `opening` and `location` list the same point, the software opens the loop after measuring the signal at the point.

Examples

Sensitivity Function at a Location

Compute the sensitivity at the plant input, marked by the analysis point X.

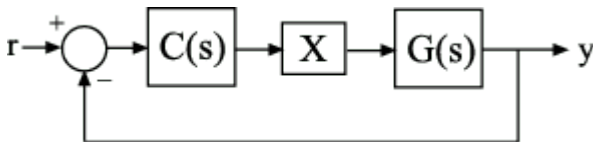

Create a model of the system by specifying and connecting a numeric LTI plant model `G`, a tunable controller `C`, and the `AnalysisPoint` block `X`. Use the `AnalysisPoint` block to mark the location where you assess the sensitivity (plant input in this example).

```
G = tf([1],[1 5]);
C = tunablePID('C','p');
C.Kp.Value = 3;
X = AnalysisPoint('X');
T = feedback(G*X*C,1);
```

`T` is a `genss` model that represents the closed-loop response of the control system from r to y . The model contains the `AnalysisPoint` block, `X`, that identifies the analysis point.

Calculate the sensitivity, S , at `X`.

```
S = getSensitivity(T,'X');
tf(S)
```



```
ans =
```

```
From input "X" to output "X":
s + 5
-----
s + 8
```

Continuous-time transfer function.

Specify Additional Loop Opening for Sensitivity Function Calculation

Calculate the inner-loop sensitivity at the output of G2, with the outer loop open.

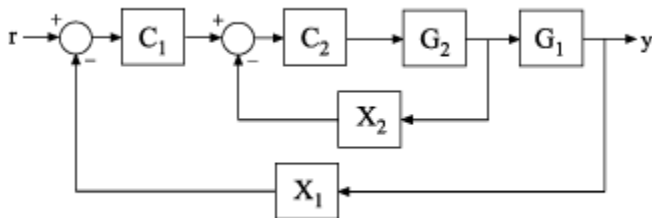

Create a model of the system by specifying and connecting the numeric plant models, tunable controllers, and AnalysisPoint blocks. G1 and G2 are plant models, C1 and C2 are tunable controllers, and X1 and X2 are AnalysisPoint blocks that mark potential loop-opening locations.

```
G1 = tf(10,[1 10]);
G2 = tf([1 2],[1 0.2 10]);
C1 = tunablePID('C','pi');
C2 = tunableGain('G',1);
X1 = AnalysisPoint('X1');
X2 = AnalysisPoint('X2');
T = feedback(G1*feedback(G2*C2,X2)*C1,X1);
```

Calculate the sensitivity, S, at X2, with the outer loop open at X1.

```
S = getSensitivity(T,'X2','X1');
tf(S)
```

```
ans =
```

```
From input "X2" to output "X2":
s^2 + 0.2 s + 10
-----
s^2 + 1.2 s + 12
```

Continuous-time transfer function.

Input Arguments

T — Model of control system

generalized state-space model

Model of a control system, specified as a generalized state-space model (*genss*).

Locations at which you can perform sensitivity analysis or open loops are marked by `AnalysisPoint` blocks in `T`. Use `getPoints(T)` to get the list of such locations.

location — Location

character vector | cell array of character vectors

Location at which you calculate the sensitivity function on page 2-448, specified as a character vector or cell array of character vectors. To extract the sensitivity function at multiple locations, use a cell array of character vectors.

Each specified location must match an analysis point in `T`. Analysis points are marked using `AnalysisPoint` blocks. To get the list of available analysis points in `T`, use `getPoints(T)`.

Example: `'u'` or `{'u','y'}`

opening — Additional loop opening

character vector | cell array of character vectors

Additional loop opening used to calculate the sensitivity function on page 2-446, specified as a character vector or cell array of character vectors. To open the loop at multiple locations, use a cell array of character vectors.

Each specified opening must match an analysis point in `T`. Analysis points are marked using `AnalysisPoint` blocks. To get the list of available analysis points in `T`, use `getPoints(T)`.

Use an opening, for example, to calculate the sensitivity function of an inner loop, with the outer loop open.

If `opening` and `location` list the same point, the software opens the loop after measuring the signal at the point.

Example: `'y_outer'` or `{'y_outer','y_outer2'}`

Output Arguments

S — Sensitivity function

generalized state-space model

Sensitivity function on page 2-448 of the control system, `T`, measured at `location`, returned as a generalized state-space model (*genss*).

- If `location` specifies a single analysis point, then `S` is a SISO *genss* model.
- If `location` is a vector signal, or specifies multiple analysis points, then `S` is a MIMO *genss* model.

More About

Sensitivity Function

The sensitivity function, also referred to simply as sensitivity, measures how sensitive a signal is to an added disturbance. Feedback reduces the sensitivity in the frequency band where the open-loop gain is greater than 1.

Consider the following model:

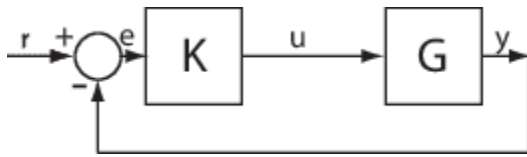

The sensitivity, S_u , at u is defined as the transfer function from du to u :

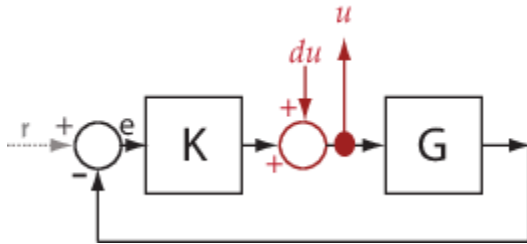

$$\begin{aligned}
 u &= du - KG u \\
 \rightarrow (I + KG)u &= du \\
 \rightarrow u &= \underbrace{(I + KG)^{-1}}_{S_u} du.
 \end{aligned}$$

Here, I is an identity matrix of the same size as KG .

Sensitivity at multiple locations, for example, u and y , is defined as the MIMO transfer function from the disturbances to sensitivity measurements:

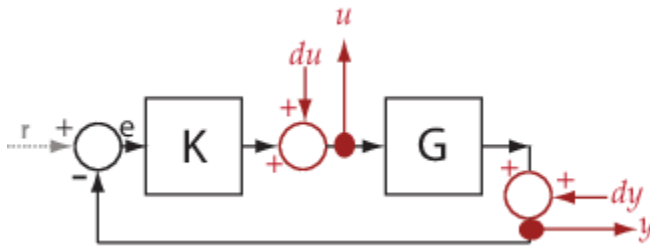

$$S = \begin{bmatrix} S_{du \rightarrow u} & S_{dy \rightarrow u} \\ S_{du \rightarrow y} & S_{dy \rightarrow y} \end{bmatrix}.$$

Version History

Introduced in R2014a

See Also

getPoints | AnalysisPoint | genss | getLoopTransfer | systune | getIOTransfer | getCompSensitivity | getValue | getSensitivity

getStateEstimate

Extract best state estimate and covariance from particles

Syntax

```
State = getStateEstimate(pf)
[State, StateCovariance] = getStateEstimate(pf)
```

Description

`State = getStateEstimate(pf)` returns the best state estimate based on the current set of particles. The estimate is extracted based on the `StateEstimationMethod` property from the `particleFilter` object, `pf`.

`[State, StateCovariance] = getStateEstimate(pf)` also returns the covariance of the state estimate. The covariance is a measure of the uncertainty of the state estimate. Not all state estimation methods support covariance output. In this case, `getStateEstimate` returns `StateCovariance` as `[]`.

The `State` and `StateCovariance` information can directly be accessed as properties of the particle filter object `pf`, as `pf.State` and `pf.StateCovariance`. However, when both these quantities are needed, using the `getStateEstimation` method with two output arguments is more computationally efficient.

Examples

State Estimation using Particle Filter

Create a particle filter, and set the state transition and measurement likelihood functions.

```
myPF = particleFilter(@vdpParticleFilterStateFcn,@vdpMeasurementLikelihoodFcn);
```

Initialize the particle filter at state `[2; 0]` with unit covariance, and use 1000 particles.

```
initialize(myPF, 1000, [2;0], eye(2));
```

Pick the mean state estimation and systematic resampling methods.

```
myPF.StateEstimationMethod = 'mean';
myPF.ResamplingMethod = 'systematic';
myPF
```

```
myPF =
```

```
particleFilter with properties:
```

```
    NumStateVariables: 2
      NumParticles: 1000
  StateTransitionFcn: @vdpParticleFilterStateFcn
MeasurementLikelihoodFcn: @vdpMeasurementLikelihoodFcn
  IsStateVariableCircular: [0 0]
```

```

    ResamplingPolicy: [1x1 particleResamplingPolicy]
    ResamplingMethod: 'systematic'
    StateEstimationMethod: 'mean'
    StateOrientation: 'column'
        Particles: [2x1000 double]
        Weights: [1.0000e-03 1.0000e-03 1.0000e-03 ... ]
        State: 'Use the getStateEstimate function to see the value.'
    StateCovariance: 'Use the getStateEstimate function to see the value.'
```

Assuming a measurement 2.1, run one predict and correct step.

```
[PredictedState, PredictedStateCovariance] = predict(myPF);
[CorrectedState, CorrectedStateCovariance] = correct(myPF,2.1);
```

Get the best state estimate and covariance based on the StateEstimationMethod property.

```
[State, StateCovariance] = getStateEstimate(myPF)
```

```
State = 2x1
```

```
    2.1018
   -0.1413
```

```
StateCovariance = 2x2
```

```
    0.0175    -0.0096
   -0.0096    0.5394
```

Input Arguments

pf — Particle filter

particleFilter object

Particle filter, specified as an object. See particleFilter for more information.

Output Arguments

State — Best state estimate

[] (default) | vector

Best state estimate, defined as a vector based on the condition of the StateOrientation property:

- If StateOrientation is 'row' then State is a 1-by-NumStateVariables vector
- If StateOrientation is 'column' then State is a NumStateVariables-by-1 vector

StateCovariance — Current estimate of state estimation error covariance

NumStateVariables-by-NumStateVariables array (default) | [] | array

Current estimate of state estimation error covariance, defined as an NumStateVariables-by-NumStateVariables array. StateCovariance is calculated based on the StateEstimationMethod. If you specify a state estimation method that does not support covariance, then the function returns StateCovariance as [].

Version History

Introduced in R2017b

See Also

`correct` | `particleFilter` | `initialize` | `predict`

Topics

“Nonlinear State Estimation Using Unscented Kalman Filter and Particle Filter”

getValue

Current value of Generalized Model

Syntax

```
curval = getValue(M)
curval = getValue(M,blockvalues)
curval = getValue(M,Mref)
```

Description

`curval = getValue(M)` returns the current value `curval` of the Generalized LTI model or Generalized matrix `M`. The current value is obtained by replacing all Control Design Blocks in `M` by their current value. (For uncertain blocks, the “current value” is the nominal value of the block.)

`curval = getValue(M,blockvalues)` uses the block values specified in the structure `blockvalues` to compute the current value. The field names and values of `blockvalues` specify the block names and corresponding values. Blocks of `M` not specified in `blockvalues` are replaced by their current values.

`curval = getValue(M,Mref)` inherits block values from the generalized model `Mref`. This syntax is equivalent to `curval = getValue(M,Mref.Blocks)`. Use this syntax to evaluate the current value of `M` using block values computed elsewhere (for example, tuned values obtained with tuning commands such as `systemtune`, `looptune`, or the Robust Control Toolbox command `hinfstruct`).

Input Arguments

M

Generalized LTI model or Generalized matrix.

blockvalues

Structure specifying blocks of `M` to replace and the values with which to replace those blocks.

The field names of `blockvalues` match names of Control Design Blocks of `M`. Use the field values to specify the replacement values for the corresponding blocks of `M`. The field values can be numeric values, dynamic system models, or static models. If some field values are Control Design Blocks or Generalized LTI models, the current values of those models are used to compute `curval`.

Mref

Generalized LTI model. If you provide `Mref`, `getValue` computes `curval` using the current values of the blocks in `Mref` whose names match blocks in `M`.

Output Arguments

curval

Numeric array or Numeric LTI model representing the current value of `M`.

If you do not specify a replacement value for a given Control Design Block of `M`, `getValue` uses the current value of that block.

Examples

Evaluate Model for Specified Values of its Blocks

This example shows how to replace a Control Design Block in a Generalized LTI model with a specified replacement value using `getValue`.

Consider the following closed-loop system:

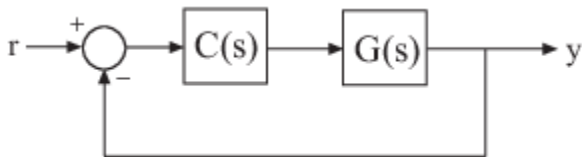

The following code creates a `genss` model of this system with $G(s) = \frac{(s-1)}{(s+1)^3}$ and a tunable PI controller `C`.

```
G = zpk(1, [-1, -1, -1], 1);
C = tunablePID('C', 'pi');
Try = feedback(G*C, 1)
```

The `genss` model `Try` has one Control Design Block, `C`. The block `C` is initialized to default values, and the model `Try` has a current value that depends on the current value of `C`. Use `getValue` to evaluate `C` and `Try` to examine the current values.

- 1 Evaluate `C` to obtain its current value.

```
Cnow = getValue(C)
```

This command returns a numeric `pid` object whose coefficients reflect the current values of the tunable parameters in `C`.

- 2 Evaluate `Try` to obtain its current value.

```
Tnow = getValue(Try)
```

This command returns a numeric model that is equivalent to `feedback(G*Cnow, 1)`.

Access Values of Tuned Models and Blocks

Propagate changes in block values from one model to another using `getValue`.

This technique is useful for accessing values of models and blocks tuned with tuning commands such as `systemtune`, `looptune`, or `hinfstruct`. For example, if you have a closed-loop model of your control system `T0`, with two tunable blocks, `C1` and `C2`, you can tune it using:

```
[T, fSoft] = systemtune(T0, SoftReqs);
```

You can then access the tuned values of `C1` and `C2`, as well as any closed-loop model `H` that depends on `C1` and `C2`, using the following:

```
C1t = getValue(C1,T);  
C2t = getValue(C2,T);  
Ht = getValue(H,T);
```

Version History

Introduced in R2011b

See Also

genss | replaceBlock | systune | looptune | hinfstruct

getx0

Map initial conditions from a `mechss` object to a `sparss` object

Syntax

```
x0 = getx0(sys,q0,dq0)
x0 = getx0(sys,q1,q2)
```

Description

`x0 = getx0(sys,q0,dq0)` computes a matching initial condition `x0` for an equivalent sparse first-order model using the initial conditions for displacement `q0` and velocity `dq0` from the continuous-time sparse second-order model `sys`. You can omit the second and third input arguments when `q0`

and `dq0` are zero. The output, $x_0 = \begin{bmatrix} q_0 \\ dq_0 \end{bmatrix} = \begin{bmatrix} q(0) \\ \frac{dq}{dt}(0) \end{bmatrix}$ when the `[sys.M;sys.G]` matrices has no zero columns.

In general, the states of the `sparss` model is $x = \begin{bmatrix} q \\ dq(jnz) \end{bmatrix}$ where `jnzs` are the indices of the nonzero columns of `[sys.M;sys.G]`. The resulting number of states n_x is $n_x = n_q + \text{numel}(jnzs) \leq 2n_q$ where n_q is the number of nodes in the `mechss` object `sys`.

`x0 = getx0(sys,q1,q2)` computes a matching initial condition using initial values `q1 = q[k]` and `q2 = q[k+1]` for discrete-time systems. The second and third input arguments can be omitted when `q0` and `dq0` are zero. The output, $x_0 = \begin{bmatrix} q_1 \\ q_2 \end{bmatrix} = \begin{bmatrix} q[k] \\ q[k+1] \end{bmatrix}$ when the `M` and `G` matrices of the `mechss` model `sys` has no zero columns.

Examples

Map Initial Conditions from Continuous-Time Sparse Second-Order Model to Equivalent First-Order Model

For this example, consider a continuous-time sparse second-order model with 108 nodes. The row vectors `q0` and `dq0` are the initial conditions for displacement and velocity, respectively. The vectors `q0` and `dq0` have the same size as the number of nodes in `sys`.

Load the data in `sparseSOC.mat` and find the initial conditions for an equivalent sparse first-order model using `getx0`.

```
load('sparseSOC.mat','sys','q0','dq0');
x0 = getx0(sys,q0,dq0);
size(x0)
```

```
ans = 1x2
```

```
216    1
```

In this case, vector x_0 contains 216 states, since $x_0 = \begin{bmatrix} q_0 \\ dq_0 \end{bmatrix}$.

Map Initial Conditions from Discrete-Time Sparse Second-Order Model to Equivalent First-Order Model

For this example, consider a discrete-time sparse second-order model with 7102 nodes. The row vectors q_1 and q_2 are the initial conditions for k and $k+1$ time steps, respectively. The vectors q_1 and q_2 have the same size as the number of nodes in `sys`.

Load the data in `sparseSOD.mat` and find the initial conditions for an equivalent discrete-time sparse first-order model using `getx0`.

```
load('sparseSOD.mat','sys','q1','q2');
x0 = getx0(sys,q1,q2);
size(x0)
```

```
ans = 1×2
```

```
14204      1
```

In this case, vector x_0 contains 14204 states since $x_0 = \begin{bmatrix} q_1 \\ q_2 \end{bmatrix}$.

Input Arguments

sys — Continuous-time or discrete-time sparse second-order model

`mechss` model object

Continuous-time or discrete-time sparse second-order model to be converted to a sparse first-order model, specified as a `mechss` model object.

For more information, see the `mechss` reference page.

q0 — Initial values of the displacement vector

row vector of length N_q

Initial values of the displacement vector, specified as a row vector of length N_q , where N_q is the number of states in the continuous-time second-order sparse model `sys`.

dq0 — Initial values of the velocity vector

row vector of length N_q

Initial values of the velocity vector, specified as a row vector of length N_q , where N_q is the number of states in the continuous-time second-order sparse model `sys`.

q1 — Initial values of state vector at k

row vector of length N_q

Initial values of state vector at k , specified as a row vector of length N_q , where N_q is the number of states in the continuous-time second-order sparse model `sys`. In other words, $q_1 = q[k]$.

q2 – Initial values of state vector at k+1row vector of length Nq

Initial values of state vector at k , specified as a row vector of length Nq , where Nq is the number of states in the continuous-time second-order sparse model `sys`. In other words, $q2 = q[k+1]$.

Output Arguments**x0 – Mapped initial conditions for the equivalent sparse first-order model**

array of doubles

Mapped initial conditions for the equivalent sparse first-order model, returned as an array of doubles. When the mass matrix M and the velocity-to-output matrix G of the `mechss` object contains no zero columns, then:

- $x0 = \begin{bmatrix} q0 \\ dq0 \end{bmatrix} = \begin{bmatrix} q(0) \\ \frac{dq}{dt}(0) \end{bmatrix}$ for continuous-time systems.
- $x0 = \begin{bmatrix} q1 \\ q2 \end{bmatrix} = \begin{bmatrix} q[k] \\ q[k + 1] \end{bmatrix}$ for discrete-time systems.

Version History

Introduced in R2020b

See Also`mechss` | `sparss`**Topics**

"Sparse Model Basics"

gram

Controllability and observability Gramians

Syntax

```
Wc = gram(sys, 'c')
Wo = gram(sys, 'o')
Wc = gram( ___, opt)
```

Description

`Wc = gram(sys, 'c')` calculates the controllability Gramian of the state-space (ss) model `sys`.

`Wo = gram(sys, 'o')` calculates the observability Gramian of the ss model `sys`.

`Wc = gram(___, opt)` calculates time-limited or frequency-limited Gramians. `opt` is an option set that specifies time or frequency intervals for the computation. Create `opt` using the `gramOptions` command.

You can use Gramians to study the controllability and observability properties of state-space models and for model reduction [1]. They have better numerical properties than the controllability and observability matrices formed by `ctrb` and `obsv`.

Given the continuous-time state-space model

$$\begin{aligned}\dot{x} &= Ax + Bu \\ y &= Cx + Du\end{aligned}$$

the controllability Gramian is defined by

$$W_c = \int_0^{\infty} e^{A\tau} B B^T e^{A^T \tau} d\tau$$

The controllability Gramian is positive definite if and only if (A, B) is controllable.

The observability Gramian is defined by

$$W_o = \int_0^{\infty} e^{A^T \tau} C^T C e^{A\tau} d\tau$$

The observability Gramian is positive definite if and only if (A, C) is observable.

The discrete-time counterparts of the controllability and observability Gramians are

$$W_c = \sum_{k=0}^{\infty} A^k B B^T (A^T)^k, \quad W_o = \sum_{k=0}^{\infty} (A^T)^k C^T C A^k$$

respectively.

Use time-limited or frequency-limited Gramians to examine the controllability or observability of states within particular time or frequency intervals. The definition of these Gramians is as described in [2].

Examples

Compute Frequency-Limited Gramian

Compute the controllability Gramian of the following state-space model. Focus the computation on the frequency interval with the most energy.

```
sys = ss([-0.1 -1; 1 0],[1;0],[0 1],0);
```

The model contains a peak at 1 rad/s. Use `gramOptions` to specify an interval around that frequency.

```
opt = gramOptions('FreqIntervals',[0.8 1.2]);
gc = gram(sys,'c',opt)
```

```
gc = 2×2
```

```
    4.2132    -0.0000
   -0.0000    4.2433
```

Limitations

The A matrix must be stable (all eigenvalues have negative real part in continuous time, and magnitude strictly less than one in discrete time).

Algorithms

The controllability Gramian W_c is obtained by solving the continuous-time Lyapunov equation

$$AW_c + W_cA^T + BB^T = 0$$

or its discrete-time counterpart

$$AW_cA^T - W_c + BB^T = 0$$

Similarly, the observability Gramian W_o solves the Lyapunov equation

$$A^TW_o + W_oA + C^TC = 0$$

in continuous time, and the Lyapunov equation

$$A^TW_oA - W_o + C^TC = 0$$

in discrete time.

The computation of time-limited and frequency-limited Gramians is as described in [2].

Version History

Introduced before R2006a

References

- [1] Kailath, T., *Linear Systems*, Prentice-Hall, 1980.
- [2] Gawronski, W. and J.N. Juang. "Model Reduction in Limited Time and Frequency Intervals."
International Journal of Systems Science. Vol. 21, Number 2, 1990, pp. 349-376.

See Also

gramOptions | hsvd | balreal | lyap | dlyap

gramOptions

Options for the gram command

Syntax

```
opt = gramOptions
opt = gramOptions(Name,Value)
```

Description

`opt = gramOptions` returns an option set with the default options for `gram`.

`opt = gramOptions(Name,Value)` returns an options set with the options specified by one or more `Name,Value` pair arguments.

Examples

Compute Frequency-Limited Gramian

Compute the controllability Gramian of the following state-space model. Focus the computation on the frequency interval with the most energy.

```
sys = ss([-0.1 -1;1 0],[1;0],[0 1],0);
```

The model contains a peak at 1 rad/s. Use `gramOptions` to specify an interval around that frequency.

```
opt = gramOptions('FreqIntervals',[0.8 1.2]);
gc = gram(sys,'c',opt)
```

```
gc = 2×2
```

```
    4.2132    -0.0000
   -0.0000    4.2433
```

Input Arguments

Name-Value Pair Arguments

Specify optional pairs of arguments as `Name1=Value1, ..., NameN=ValueN`, where `Name` is the argument name and `Value` is the corresponding value. Name-value arguments must appear after other arguments, but the order of the pairs does not matter.

Before R2021a, use commas to separate each name and value, and enclose `Name` in quotes.

Example: `'FreqIntervals',[0.8 1.2]`

FreqIntervals — Frequency intervals for computing Gramians

`[]` (default) | two-column matrix

Frequency intervals for computing frequency-limited controllability and observability Gramians, specified as a matrix with two columns. Each row specifies a frequency interval $[f_{\min} \ f_{\max}]$, where f_{\min} and f_{\max} are nonnegative frequencies, expressed in the frequency unit of the model. For example:

- To restrict the computation to the range between 3 rad/s and 15 rad/s, assuming the frequency unit of the model is rad/s, set `FreqIntervals` to `[3 15]`.
- To restrict the computation to two frequency intervals, 3-15 rad/s and 40-60 rad/s, use `[3 15; 40 60]`.
- To specify all frequencies below a cutoff frequency `fcut`, use `[0 fcut]`.
- To specify all frequencies above the cutoff, use `[fcut Inf]` in continuous time, or `[fcut pi/Ts]` in discrete time, where T_s is the sample time of the model.

The default value, `[]`, imposes no frequency limitation and is equivalent to `[0 Inf]` in continuous time or `[0 pi/Ts]` in discrete time. However, if you specify a `TimeIntervals` value other than `[]`, then this limit overrides `FreqIntervals = []`. If you specify both a `TimeIntervals` value and a `FreqIntervals` value, then the computation uses the union of these intervals.

TimeIntervals — Time intervals for computing Gramians

`[]` (default) | two-column matrix

Time intervals for computing time-limited controllability and observability Gramians, specified as a matrix with two columns. Each row specifies a time interval $[t_{\min} \ t_{\max}]$, where t_{\min} and t_{\max} are nonnegative times, expressed in the time unit of the model. For example:

- To restrict the computation to the range between 3 s and 15 s, assuming the time unit of the model is seconds, set `TimeIntervals` to `[3 15]`.
- To restrict the computation to two time intervals, 3-15 s and 40-60 s, use `[3 15; 40 60]`.
- To specify all times from zero up to a cutoff time `tcut`, use `[0 tcut]`. To specify all times after the cutoff, use `[tcut Inf]`.

The default value, `[]`, imposes no time limitation and is equivalent to `[0 Inf]`. However, if you specify a `FreqIntervals` value other than `[]`, then this limit overrides `Timeintervals = []`. If you specify both a `TimeIntervals` value and a `FreqIntervals` value, then the computation uses the union of these intervals.

Output Arguments

opt — Options for `gram`

`gramOptions options set`

Options for `gram`, returned as a `gramOptions options set`. Use `opt` as the last argument to `gram` to compute time-limited or frequency-limited Gramians.

Version History

Introduced in R2016a

See Also

`gram` | `hsvd`

hasdelay

True for linear model with time delays

Syntax

```
B = hasdelay(sys)
B = hasdelay(sys, 'elem')
```

Description

`B = hasdelay(sys)` returns 1 (true) if the model `sys` has input delays, output delays, I/O delays, or internal delays, and 0 (false) otherwise. If `sys` is a model array, then `B` is true if least one model in `sys` has delays.

`B = hasdelay(sys, 'elem')` returns a logical array of the same size as the model array `sys`. The logical array indicates which models in `sys` have delays.

Version History

Introduced before R2006a

See Also

`absorbDelay` | `totaldelay`

hasInternalDelay

Determine if model has internal delays

Syntax

```
B = hasInternalDelay(sys)
B = hasInternalDelay(sys, 'elem')
```

Description

`B = hasInternalDelay(sys)` returns 1 (true) if the model `sys` has internal delays, and 0 (false) otherwise. If `sys` is a model array, then `B` is true if at least one model in `sys` has delays.

`B = hasInternalDelay(sys, 'elem')` checks each model in the model array `sys` and returns a logical array of the same size as `sys`. The logical array indicates which models in `sys` have internal delays.

Examples

Check Model for Internal Delays

Build a dynamic system model of the following closed-loop system.

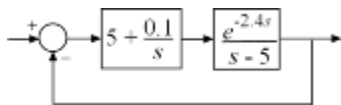

```
s = tf('s');
G = exp(-2.4*s)/(s-5);
C = pid(5,0.1);
sys = feedback(G*C,1);
```

Check the model for internal delays.

```
B = hasInternalDelay(sys)
```

```
B = logical
     1
```

The model, `sys`, has an internal delay because of the transport delay in the plant `G`. Therefore, `hasInternalDelay` returns 1.

Input Arguments

sys — Model or array to check

dynamic system model | model array

Model or array to check for internal delays, specified as a dynamic system model or array of dynamic system models.

Output Arguments

B – Flag indicating presence of internal delays

logical | logical array

Flag indicating presence of internal delays in input model or array, returned as a logical value or logical array.

Version History

Introduced in R2013a

See Also

hasdelay | getDelayModel

hsvd

(Not recommended) Hankel singular values of dynamic system

Note `hsvd` is not recommended. Use `balred` instead. For more information, see “Compatibility Considerations”.

Syntax

```
hsv = hsvd(sys)
hsv = hsvd(sys,opts)
[hsv,baldata] = hsvd(____)
hsvd(____)
```

Description

`hsv = hsvd(sys)` computes the Hankel singular values `hsv` of the dynamic system `sys`. In state coordinates that equalize the input-to-state and state-to-output energy transfers, the Hankel singular values measure the contribution of each state to the input/output behavior. Hankel singular values are to model order what singular values are to matrix rank. In particular, small Hankel singular values signal states that can be discarded to simplify the model (see `balred`).

For models with unstable poles, `hsvd` only computes the Hankel singular values of the stable part and entries of `hsv` corresponding to unstable modes are set to `Inf`.

`hsv = hsvd(sys,opts)` computes the Hankel singular values using options that you specify using `hsvdOptions`. Options include offset and tolerance options for computing the stable-unstable decompositions. The options also allow you to limit the HSV computation to energy contributions within particular time and frequency intervals. See `balredOptions` for details.

`[hsv,baldata] = hsvd(____)` returns additional data to speed up model order reduction. You can use this syntax with any of the previous combinations of input arguments.

`hsvd(____)` displays a Hankel singular values plot.

Examples

Compute Hankel Singular Values of System With Near-Unstable Pole

Create a system with a stable pole very near to 0, and display the Hankel singular values.

```
sys = zpk([1 2],[-1 -2 -3 -10 -1e-7],1);
hsv = hsvd(sys)
```

```
hsv = 5×1
105 ×

    1.6667
    0.0000
```

```
0.0000
0.0000
0.0000
```

Notice the dominant Hankel singular value with magnitude 10^5 , which is so much larger that the significant digits of the other modes are not displayed. This value is due to the near-unstable mode at $s = 10^{-7}$. Use the 'Offset' option to treat this mode as unstable.

```
opts = hsvdOptions('Offset',1e-7);
hsvu = hsvd(sys,opts)
```

```
hsvu = 5×1
```

```
      Inf
0.0688
0.0138
0.0024
0.0001
```

The Hankel singular value of modes that are unstable, or treated as unstable, is returned as `Inf`. Create a Hankel singular-value plot while treating this mode as unstable.

```
hsvd(sys,opts)
```

```
ans = 5×1
```

```
      Inf
0.0688
0.0138
0.0024
0.0001
```

The unstable mode is shown in red on the plot.

By default, `hsvd` uses a linear scale. To switch the plot to a log scale, right-click on the plot and select **Y Scale > Log**. For information about programmatically changing properties of HSV plots, see `hsvplot`.

Frequency-Limited Hankel Singular Values

Compute the Hankel singular values of a model with low-frequency and high-frequency dynamics. Focus the calculation on the high-frequency modes.

Load the model and examine its frequency response.

```
load modeselect Gms
bodeplot(Gms)
```

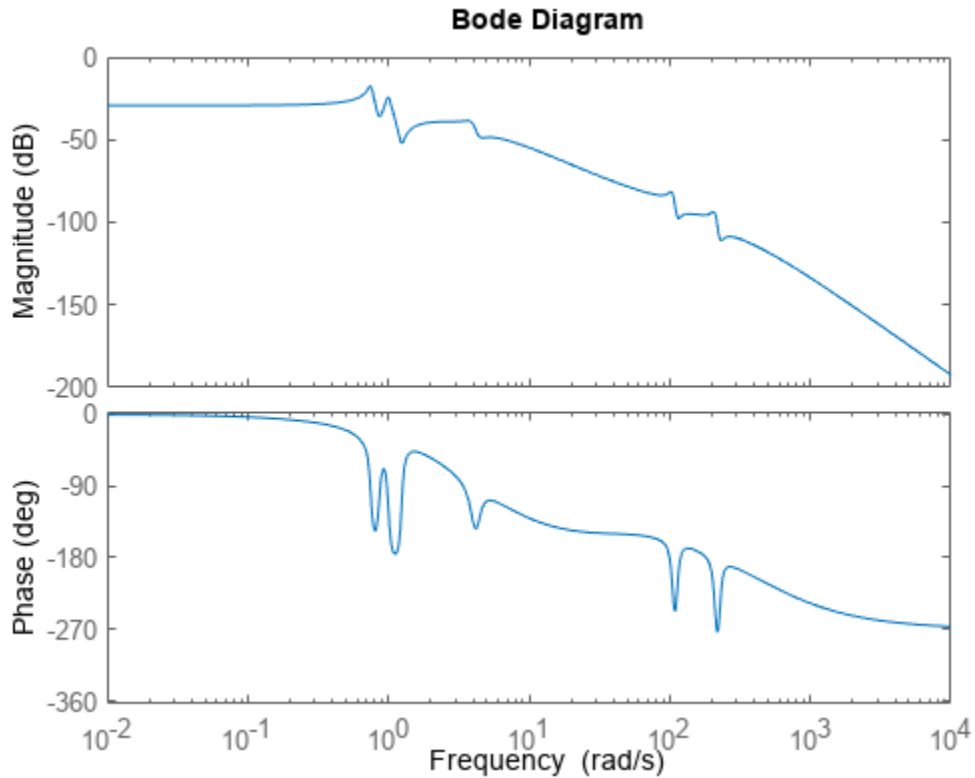

Gms has two sets of resonances, one at relatively low frequency and the other at relatively high frequency. Compute the Hankel singular values of the high-frequency modes, excluding the energy contributions to the low-frequency dynamics. To do so, use `hsvdOptions` to specify a frequency interval above 30 rad/s.

```
opts = hsvdOptions('FreqInterval',[30 Inf]);
hsvd(Gms,opts)
```

```
ans = 18x1
10-4 ×
```

```
0.6237
0.4558
0.3183
0.2468
0.0895
0.0847
0.0243
0.0028
0.0000
0.0000
⋮
```

Tips

To create a Hankel singular-value plot with more flexibility to programmatically customize the plot, use `hsvplot`.

Version History

Introduced before R2006a

hsvd is not recommended

Not recommended starting in R2021a

Starting in R2021a, use the `balred` command to compute Hankel singular values. This approach facilitates better workflow since you can also compute reduced-order model approximations using the same command. Furthermore, the enhanced workflow also includes new options that preserve roll-off characteristics.

The following table shows some typical uses of `hsvd` and how to update your code to use `balred` instead.

Not Recommended	Recommended
<code>hsv = hsvd(sys)</code>	<code>[~,info] = balred(sys,order)</code> computes the Hankel singular values and the error approximations of <code>sys</code> . For more information, see <code>balred</code> .
<code>hsv = hsvd(sys,opts)</code>	<code>[~,info] = balred(sys,order,opts)</code> computes the Hankel singular values with options specified in the option set <code>opts</code> . For more information, see <code>balred</code> .

There are no plans to remove `hsvd` at this time.

See Also

`balredOptions` | `hsvplot` | `balred` | `balreal`

hsvdOptions

(Not recommended) Create option set for computing Hankel singular values and input/output balancing

Note `hsvdOptions` is not recommended. Use `balredOptions` instead. For more information, see “Compatibility Considerations”.

Syntax

```
opts = hsvdOptions
opts = hsvdOptions(Name,Value)
```

Description

`opts = hsvdOptions` returns the default options for the `hsvd` and `balreal` commands.

`opts = hsvdOptions(Name,Value)` returns an options set with the options specified by one or more `Name,Value` pair arguments.

Input Arguments

Name-Value Pair Arguments

Specify comma-separated pairs of `Name,Value` arguments. `Name` is the argument name and `Value` is the corresponding value. `Name` must appear inside single quotes (' '). You can specify several name and value pair arguments in any order as `Name1,Value1,...,NameN,ValueN`.

FreqIntervals

Frequency intervals for computing frequency-limited Hankel singular values (`balred`) or balanced realization (`balreal`), specified as a matrix with two columns. Each row specifies a frequency interval `[fmin fmax]`, where `fmin` and `fmax` are nonnegative frequencies, expressed in the frequency unit of the model. For example:

- To restrict the computation to the range between 3 rad/s and 15 rad/s, assuming the frequency unit of the model is rad/s, set `FreqIntervals` to `[3 15]`.
- To restrict the computation to two frequency intervals, 3-15 rad/s and 40-60 rad/s, use `[3 15; 40 60]`.
- To specify all frequencies below a cutoff frequency `fcut`, use `[0 fcut]`.
- To specify all frequencies above the cutoff, use `[fcut Inf]` in continuous time, or `[fcut pi/Ts]` in discrete time, where `Ts` is the sample time of the model.

The default value, `[]`, imposes no frequency limitation and is equivalent to `[0 Inf]` in continuous time or `[0 pi/Ts]` in discrete time. However, if you specify a `TimeIntervals` value other than `[]`, then this limit overrides `FreqIntervals = []`. If you specify both a `TimeIntervals` value and a `FreqIntervals` value, then the computation uses the union of these intervals.

Default: `[]`

TimeIntervals

Time intervals for computing time-limited Hankel singular values (`balred`) or balanced realization (`balreal`), specified as a matrix with two columns. Each row specifies a time interval [`tmin tmax`], where `tmin` and `tmax` are nonnegative times, expressed in the time unit of the model. The software computes state contributions to the system's impulse response in these time intervals only. For example:

- To restrict the computation to the range between 3 s and 15 s, assuming the time unit of the model is seconds, set `TimeIntervals` to `[3 15]`.
- To restrict the computation to two time intervals, 3-15 s and 40-60 s, use `[3 15; 40 60]`.
- To specify all times from zero up to a cutoff time `tcut`, use `[0 tcut]`. To specify all times after the cutoff, use `[tcut Inf]`.

The default value, `[]`, imposes no time limitation and is equivalent to `[0 Inf]`. However, if you specify a `FreqIntervals` value other than `[]`, then this limit overrides `Timeintervals = []`. If you specify both a `TimeIntervals` value and a `FreqIntervals` value, then the computation uses the union of these intervals.

SepTol

Maximum loss of accuracy value in stable and unstable decomposition. For models with unstable poles, `balred` first extracts the stable dynamics using `stabsep`. Use 'SepTol' to control the decomposition accuracy.

For more information, see `balredOptions`.

Default: `SepTol = 'auto'`

Offset

Offset for the stable/unstable boundary. Positive scalar value. In the stable/unstable decomposition, the stable term includes only poles satisfying:

- $\text{Re}(s) < -\text{Offset} * \max(1, |\text{Im}(s)|)$ (Continuous time)
- $|z| < 1 - \text{Offset}$ (Discrete time)

Increase the value of `Offset` to treat poles close to the stability boundary as unstable.

Default: `1e-8`

For additional information on the options and how they affect the calculation, see `balredOptions`. The time-limited and frequency-limited state contributions are calculated using the time-limited and frequency-limited controllability and observability Gramians, as described in `gram` and in [1].

Examples

Hankel Singular-Value Plot with Near-Unstable Pole

Compute the Hankel singular values of the system given by:

$$\text{sys} = \frac{(s + 0.5)}{(s + 10^{-6})(s + 2)}$$

Use the `Offset` option to force `hsvd` to exclude the pole at $s = 10^{-6}$ from the stable term of the stable/unstable decomposition.

```
sys = zpk(-.5, [-1e-6 -2], 1);
opts = hsvdOptions('Offset', .001);
hsvd(sys, opts)
```

```
ans = 2×1
      Inf
    0.1875
```

The plot shows that one state is treated as unstable. `hsvd` computes the energy contributions of the stable states only.

Frequency-Limited Hankel Singular Values

Compute the Hankel singular values of a model with low-frequency and high-frequency dynamics. Focus the calculation on the high-frequency modes.

Load the model and examine its frequency response.

```
load modeselect Gms
bodeplot(Gms)
```

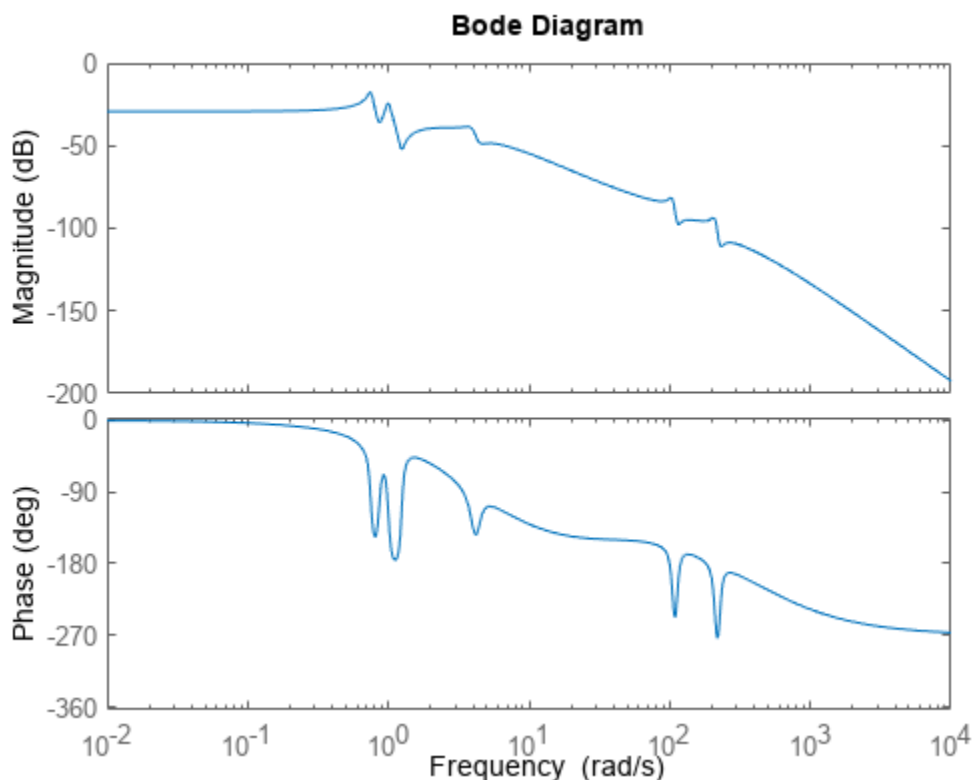

Gms has two sets of resonances, one at relatively low frequency and the other at relatively high frequency. Compute the Hankel singular values of the high-frequency modes, excluding the energy contributions to the low-frequency dynamics. To do so, use `hsvdOptions` to specify a frequency interval above 30 rad/s.

```
opts = hsvdOptions('FreqInterval',[30 Inf]);
hsvd(Gms,opts)
```

```
ans = 18×1
10-4 ×
```

```
0.6237
0.4558
0.3183
0.2468
0.0895
0.0847
0.0243
0.0028
0.0000
0.0000
⋮
```

Version History

Introduced in R2010a

hsvdOptions is not recommended

Not recommended starting in R2021a

Starting in R2021a, use the `balredOptions` command to create the options set with your specific options. `balredOptions` also includes new options that preserve roll-off characteristics.

The following table shows some typical uses of `hsvd` and how to update your code to use `balredOptions` instead.

Not Recommended	Recommended
<code>opts = hsvdOptions(Name,Value)</code>	<code>opts = balredOptions(Name,Value)</code> creates the option set with the specified options. For more information, see <code>balredOptions</code> .

There are no plans to remove `hsvdOptions` at this time.

References

[1] Gawronski, W. and J.N. Juang. "Model Reduction in Limited Time and Frequency Intervals." *International Journal of Systems Science*. Vol. 21, Number 2, 1990, pp. 349-376.

See Also

`balreal` | `gram` | `balred` | `balredOptions`

hsvoptions

Create list of Hankel singular value plot options

Description

Use the `hsvoptions` command to create a `HSVOptions` object to customize Hankel singular value (HSV) plot appearance. You can also use the command to override the plot preference settings in the MATLAB session in which you create the HSV plots.

Creation

Syntax

```
plotoptions = hsvoptions
plotoptions = hsvoptions('cstprefs')
```

Description

`plotoptions = hsvoptions` returns a default set of plot options for use with the `hsvplot` command. You can use these options to customize the HSV plot appearance using the command line. This syntax is useful when you want to write a script to generate plots that look the same regardless of the preference settings of the MATLAB session in which you run the script.

`plotoptions = hsvoptions('cstprefs')` initializes the plot options with the options you selected in the Control System Toolbox Preferences Editor. For more information about the editor, see "Toolbox Preferences Editor". This syntax is useful when you want to change a few plot options but otherwise use your default preferences. A script that uses this syntax may generate results that look different when run in a session with different preferences.

Properties

YScale — Scale for Y-axis

'log' (default) | 'linear'

Scale for Y-axis, specified as either 'log' or 'linear'.

Title — Title text and style

structure (default)

Title text and style, specified as a structure with the following fields:

- **String** — Label text, specified as a character vector. By default, the plot is titled 'Hankel Singular Values and Approximation Error'.
- **FontSize** — Font size, specified as a scalar value greater than zero in point units. The default font size depends on the specific operating system and locale. One point equals 1/72 inch.

- **FontWeight** — Character thickness, specified as 'Normal' or 'bold'. MATLAB uses the **FontWeight** property to select a font from those available on your system. Not all fonts have a bold weight. Therefore, specifying a bold font weight can still result in the normal font weight.
- **FontAngle** — Character slant, specified as 'Normal' or 'italic'. Not all fonts have both font styles. Therefore, the italic font might look the same as the normal font.
- **Color** — Text color, specified as an RGB triplet. The default color is black specified by the RGB triplet $[0, 0, 0]$.
- **Interpreter** — Text interpreter, specified as one of these values:
 - 'tex' — Interpret characters using a subset of TeX markup. This is the default value of **Interpreter**.
 - 'latex' — Interpret characters using LaTeX markup.
 - 'none' — Display literal characters.

XLabel — X-axis label text and style

structure (default)

X-axis label text and style, specified as a structure with the following fields:

- **String** — Label text, specified as a character vector. By default, the axis is titled 'Order (Number of States)'.
- **FontSize** — Font size, specified as a scalar value greater than zero in point units. The default font size depends on the specific operating system and locale. One point equals 1/72 inch.
- **FontWeight** — Character thickness, specified as 'Normal' or 'bold'. MATLAB uses the **FontWeight** property to select a font from those available on your system. Not all fonts have a bold weight. Therefore, specifying a bold font weight can still result in the normal font weight.
- **FontAngle** — Character slant, specified as 'Normal' or 'italic'. Not all fonts have both font styles. Therefore, the italic font might look the same as the normal font.
- **Color** — Text color, specified as an RGB triplet. The default color is black specified by the RGB triplet $[0, 0, 0]$.
- **Interpreter** — Text interpreter, specified as one of these values:
 - 'tex' — Interpret characters using a subset of TeX markup. This is the default value of **Interpreter**.
 - 'latex' — Interpret characters using LaTeX markup.
 - 'none' — Display literal characters.

YLabel — Y-axis label text and style

structure (default)

Y-axis label text and style, specified as a structure with the following fields:

- **String** — Label text, specified as a cell array of character vectors. By default, the axis label is titled 'State Contribution'.
- **FontSize** — Font size, specified as a scalar value greater than zero in point units. The default font size depends on the specific operating system and locale. One point equals 1/72 inch.
- **FontWeight** — Character thickness, specified as 'Normal' or 'bold'. MATLAB uses the **FontWeight** property to select a font from those available on your system. Not all fonts have a bold weight. Therefore, specifying a bold font weight can still result in the normal font weight.

- **FontAngle** — Character slant, specified as 'Normal' or 'italic'. Not all fonts have both font styles. Therefore, the italic font might look the same as the normal font.
- **Color** — Text color, specified as an RGB triplet. The default color is black specified by the RGB triplet [0,0,0].
- **Interpreter** — Text interpreter, specified as one of these values:
 - 'tex' — Interpret characters using a subset of TeX markup. This is the default value of Interpreter.
 - 'latex' — Interpret characters using LaTeX markup.
 - 'none' — Display literal characters.

TickLabel — Tick label style

structure (default)

Tick label style, specified as a structure with the following fields:

- **FontSize** — Font size, specified as a scalar value greater than zero in point units. The default font size depends on the specific operating system and locale. One point equals 1/72 inch.
- **FontWeight** — Character thickness, specified as 'Normal' or 'bold'. MATLAB uses the **FontWeight** property to select a font from those available on your system. Not all fonts have a bold weight. Therefore, specifying a bold font weight can still result in the normal font weight.
- **FontAngle** — Character slant, specified as 'Normal' or 'italic'. Not all fonts have both font styles. Therefore, the italic font might look the same as the normal font.
- **Color** — Text color, specified as an RGB triplet. The default color is black specified by the RGB triplet [0,0,0].

Grid — Toggle grid display

'off' (default) | 'on'

Toggle grid display on the plot, specified as either 'off' or 'on'.

GridColor — Color of the grid lines

[0.15,0.15,0.15] (default) | RGB triplet

Color of the grid lines, specified as an RGB triplet. The default color is light grey specified by the RGB triplet [0.15,0.15,0.15].

XLimMode — X-axis limit selection mode

'auto' (default) | 'manual' | cell array

Selection mode for the x-axis limits, specified as one of these values:

- 'auto' — Enable automatic limit selection, which is based on the total span of the plotted data.
- 'manual' — Manually specify the axis limits. To specify the axis limits, set the **XLim** property.

YLimMode — Y-axis limit selection mode

'auto' (default) | 'manual' | cell array

Selection mode for the y-axis limits, specified as one of these values:

- 'auto' — Enable automatic limit selection, which is based on the total span of the plotted data.

- 'manual' — Manually specify the axis limits. To specify the axis limits, set the `YLim` property.

XLim — X-axis limits

'{[1,10]}' (default) | cell array of two-element vector of the form [min,max] | cell array

X-axis limits, specified as a cell array of two-element vector of the form [min,max].

YLim — Y-axis limits

'{[1,10]}' (default) | cell array of two-element vector of the form [min,max] | cell array

Y-axis limits, specified as a cell array of two-element vector of the form [min,max].

Object Functions

`hsvplot` Plot Hankel singular values and return plot handle

Examples**Set Properties in HSV Plot**

Use `hsvplot` to create a Hankel singular-value plot and customized plot properties.

Create an options set for `hsvplot` that sets the `Yscale` property and the title font size.

```
P = hsvoptions;  
P.YScale = 'linear';  
P.Title.FontSize = 14;
```

Use the options set to generate an HSV plot. Note the linear y-axis scale in the plot.

```
h = hsvplot(rss(12),P);
```

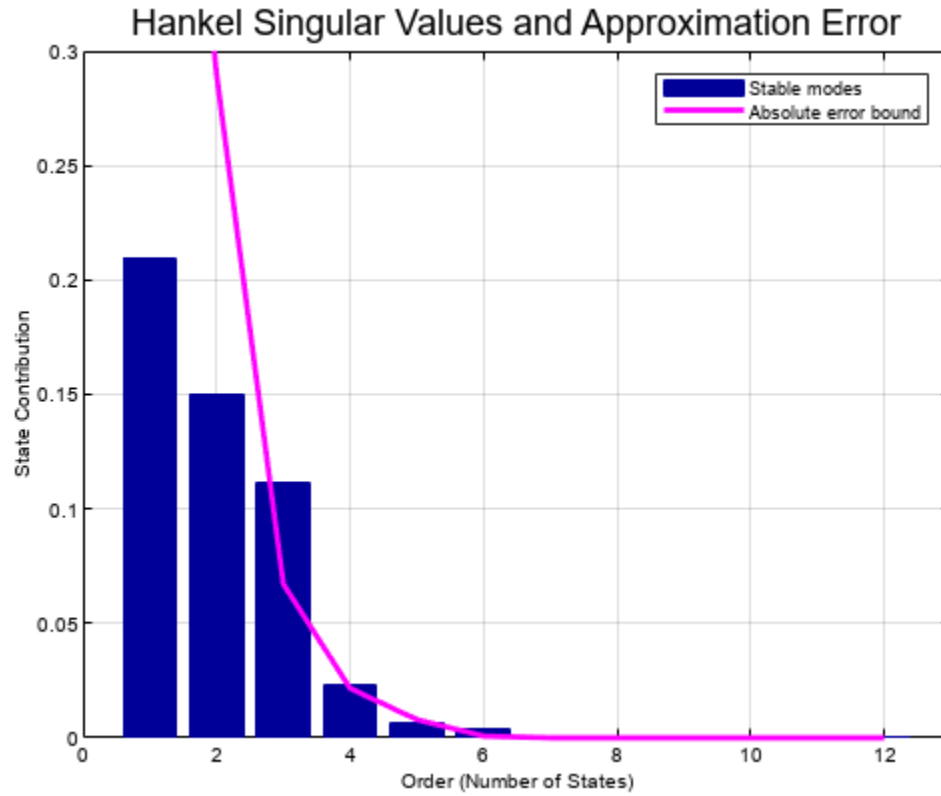
`hsvplot` returns a plot handle. You can use the plot handle to change properties of the existing plot. For example, switch to log scale and turn off the grid.

```
setoptions(h, 'Yscale', 'log', 'Grid', 'Off')
```

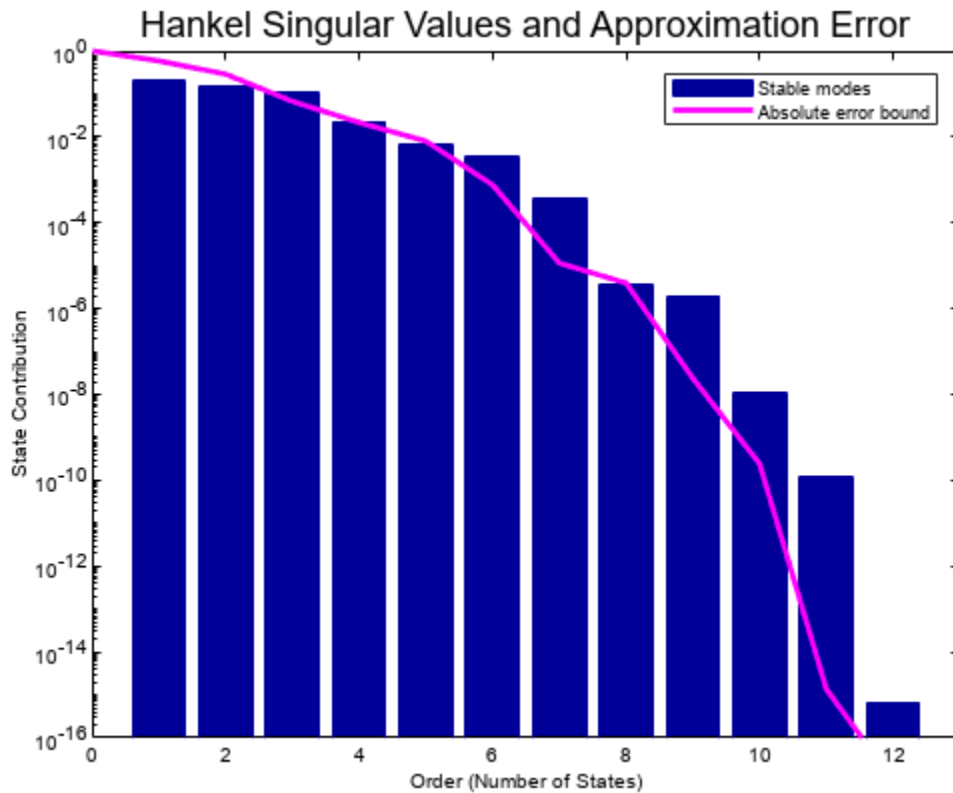

Tips

- Both `balred` and `hsvplot` generate Hankel singular-value plots. `hsvplot` is useful when you want to customize properties of your plot such as axis limits, scale, and label styles. Use `hsvoptions` with `hsvplot` to define properties for your plot. For information on the ways to change properties of your plots, see “Ways to Customize Plots”.

Version History

Introduced in R2008a

See Also

`balred` | `balredOptions` | `hsvplot` | `getoptions` | `setoptions` | `stabsep`

Topics

“Toolbox Preferences Editor”

hsvplot

Plot Hankel singular values and return plot handle

Syntax

```
hsvplot(sys)
hsvplot(AX,sys,...)
hsvplot(...,numOpts,plotOpts)
h = hsvplot(____)
```

Description

`hsvplot(sys)` plots the Hankel singular values (HSVs) of the LTI model `sys`. See `balred` for details on the meaning and purpose of Hankel singular values. The Hankel singular values for the stable and unstable modes of `sys` are shown in blue and red, respectively. Reduced-order models of various orders can be obtained by dropping the states associated with the smallest HSVs. `hsvplot` also shows the maximum approximation error as a function of the approximation order (number of states in reduced-order model).

`hsvplot(AX,sys,...)` attaches the plot to the axes `AX`.

`hsvplot(...,numOpts,plotOpts)` specifies additional options for computing and plotting the results. Use `balredOptions` to create `numOpts` and `hsvoptions` to create `plotOpts`.

`h = hsvplot(____)` returns the plot handle `h` to the Hankel singular value plot. You can use this handle to customize the plot with the `getoptions` and `setoptions` commands. See `hsvoptions` for a list of some available plot options.

Examples

Set Properties in HSV Plot

Use `hsvplot` to create a Hankel singular-value plot and customized plot properties.

Create an options set for `hsvplot` that sets the `Yscale` property and the title font size.

```
P = hsvoptions;
P.YScale = 'linear';
P.Title.FontSize = 14;
```

Use the options set to generate an HSV plot. Note the linear y-axis scale in the plot.

```
h = hsvplot(rss(12),P);
```

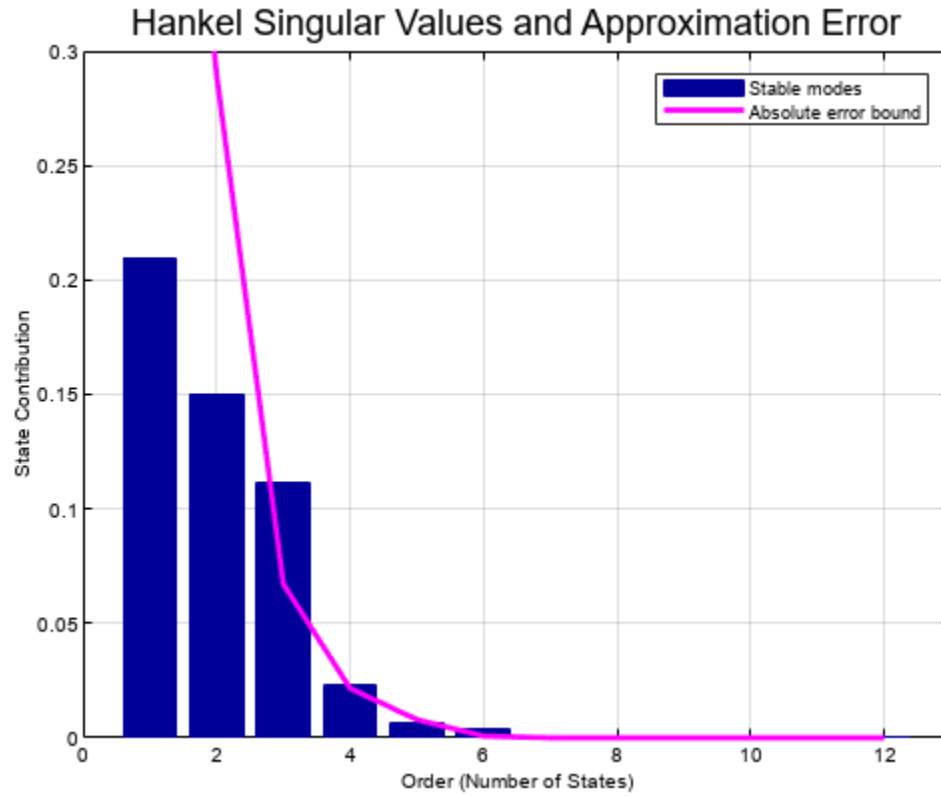

`hsvplot` returns a plot handle. You can use the plot handle to change properties of the existing plot. For example, switch to log scale and turn off the grid.

```
setoptions(h, 'Yscale', 'log', 'Grid', 'Off')
```

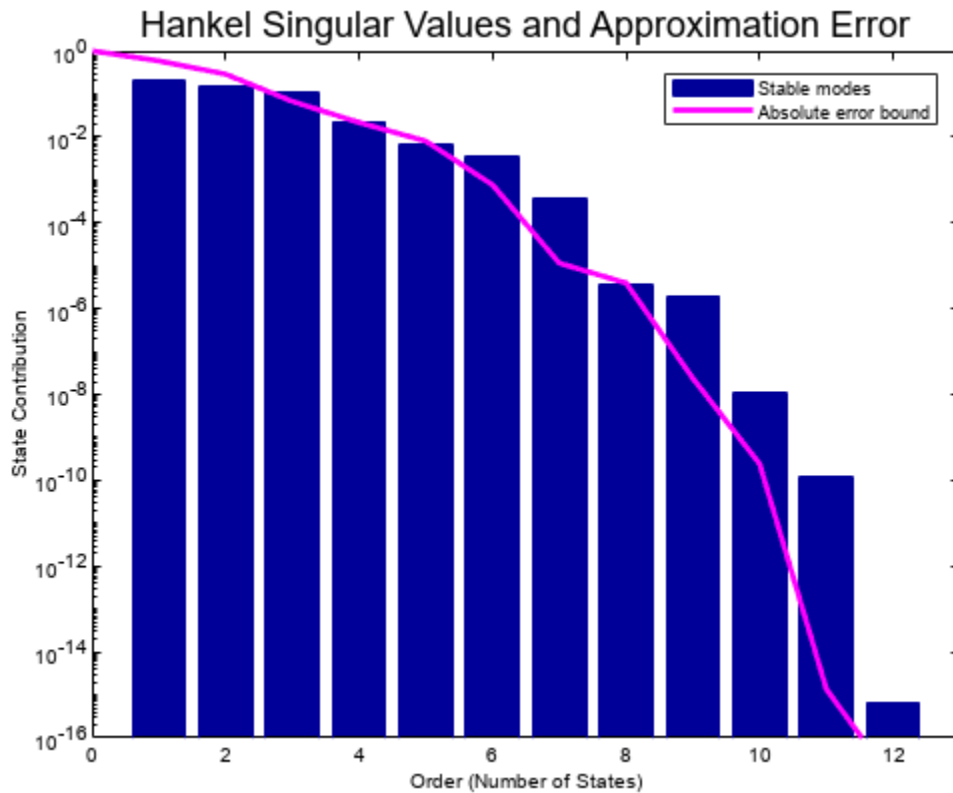

Tips

- Both `balred` and `hsvplot` generate Hankel singular-value plots. `hsvplot` is useful when you want to customize properties of your plot such as axis limits, scale, and label styles. Use `hsvoptions` with `hsvplot` to define properties for your plot. For information on the ways to change properties of your plots, see “Ways to Customize Plots”.

Version History

Introduced before R2006a

See Also

`balred` | `balredOptions` | `getoptions` | `hsvoptions` | `setoptions`

icare

Implicit solver for continuous-time algebraic Riccati equations

Syntax

```
[X,K,L] = icare(A,B,Q,R,S,E,G)
[X,K,L,info] = icare(____)
[____] = icare(____, 'noscaling')
[____] = icare(____, 'anti')
```

Description

`[X,K,L] = icare(A,B,Q,R,S,E,G)` computes the unique stabilizing solution X , state-feedback gain K , and the closed-loop eigenvalues L of the following continuous-time algebraic Riccati equation.

$$A^T X E + E^T X A + E^T X G X E - (E^T X B + S) R^{-1} (B^T X E + S^T) + Q = 0$$

The stabilizing solution X puts all the eigenvalues L in the left half-plane.

Algebraic Riccati equations play a key role in LQR/LQG control, H2- and H-infinity control, Kalman filtering, and spectral or co-prime factorizations.

`[X,K,L,info] = icare(____)` also returns a structure `info` which contains additional information about the solution to the continuous-time algebraic Riccati equation.

`[____] = icare(____, 'noscaling')` turns off the built-in scaling and sets all entries of the scaling vectors `info.Sx` and `info.Sr` to 1. Turning off scaling speeds up computation but can be detrimental to accuracy when A, B, Q, R, S, E, G are poorly scaled.

`[____] = icare(____, 'anti')` computes the anti-stabilizing solution X that puts all eigenvalues L in the right half-plane.

Examples

Solve Continuous-Time Algebraic Riccati Equation

To solve the algebraic Riccati equation $A^T X + X A - X B B^T X + C C^T = 0$, consider the following matrices:

$$A = \begin{bmatrix} 1 & -2 & 3 \\ -4 & 5 & 6 \\ 7 & 8 & 9 \end{bmatrix} \quad B = \begin{bmatrix} 5 \\ 6 \\ -7 \end{bmatrix} \quad C = [7 \ -8 \ 9].$$

The least effort approach is to use $G = -B B^T$ and $Q = C^T C$, and then find the solution using `icare`.

```
A = [-1,2,3;4,5,-6;7,-8,9];
B = [5;6;-7];
C = [7,-8,9];
```

```
G = -B*B';
Q = C'*C;
[X1,K1,L1] = icare(A,[],Q,[],[],[],G)
```

```
X1 = 3×3
```

```
    15.3201    4.2369    17.0090
     4.2369    2.6252    4.4123
    17.0090    4.4123    19.0374
```

```
K1 =
```

```
    0×3 empty double matrix
```

```
L1 = 3×1
```

```
   -3.2139
  -10.1191
  -76.9693
```

The above approach may lead to numerical inaccuracies when matrices B and C have large entries, since they are squared-up to compute the G and Q matrices. Due to limited numerical range, the computation may be less accurate or even fail. For example, if $\text{norm}(B)$ is $1e6$, then $\text{norm}(G)$ is $1e12$, and any eigenvalue within $1e-4$ of the imaginary axis may be diagnosed as 'imaginary' due to numerical errors.

For greater numerical accuracy, re-write the algebraic Riccati equation in the following way:

$$A^T X + XA - [XB, C^T] * [I, 0; 0, -I] [B^T X; C] = 0.$$

The above equation is the standard form of $A^T X + XA - (XB + S)R^{-1}(B^T X + S^T) = 0$,

where $B = [B, 0]$, $S = [0, C^T]$, and $R = [I, 0; 0, -I]$.

Compute the solution using `icare` with the above values.

```
n = size(A,1);
m = size(B,2);
p = size(C,1);
R = blkdiag(eye(m), -eye(p));
BB = [B,zeros(n,p)];
S = [zeros(n,m),C'];
[X2,K2,L2,info] = icare(A,BB,0,R,S,[],[])
```

```
X2 = 3×3
```

```
    15.3201    4.2369    17.0090
     4.2369    2.6252    4.4123
    17.0090    4.4123    19.0374
```

```
K2 = 2×3
```

```
   -17.0406    6.0501   -21.7435
```

```

-7.0000    8.0000   -9.0000

L2 = 3×1

-3.2139
-10.1191
-76.9693

info = struct with fields:
    Sx: [3×1 double]
    Sr: [2×1 double]
    U: [3×3 double]
    V: [3×3 double]
    W: [2×3 double]
    Report: 0

```

Here, X2 is the unique stabilizing solution, K2 contains the state-feedback gain and L2 contains the closed-loop eigenvalues.

Anti-Stabilizing Solution of Continuous-Time Algebraic Riccati Equation

To find the anti-stabilizing solution of the continuous-time algebraic Riccati equation $A^T X + XA - XBB^T X + CC^T = 0$, consider the following matrices:

$$A = \begin{bmatrix} 1 & -2 & 3 \\ -4 & 5 & 6 \\ 7 & 8 & 9 \end{bmatrix} \quad B = \begin{bmatrix} 5 \\ 6 \\ -7 \end{bmatrix} \quad C = [7 \ -8 \ 9].$$

For greater numerical accuracy, re-write the algebraic Riccati equation in the following way:

$$A^T X + XA - [XB, C^T] * [I, 0; 0, -I] [B^T X; C] = 0.$$

The above equation is the standard form of $A^T X + XA - (XB + S)R^{-1}(B^T X + S^T) = 0$,

where $B = [B, 0]$, $S = [0, C^T]$, and $R = [I, 0; 0, -I]$.

Compute the anti-stabilizing solution using the 'anti' option.

```

A = [-1,2,3;4,5,-6;7,-8,9];
B = [5;6;-7];
C = [7,-8,9];
n = size(A,1);
m = size(B,2);
p = size(C,1);
R = blkdiag(eye(m),-eye(p));
BB = [B,zeros(n,p)];
S = [zeros(n,m),C'];
[X,K,L] = icare(A,BB,0,R,S,[],[],'anti')

```

$X = 3 \times 3$

```
-18.0978  10.9090  -1.8466
 10.9090  -6.7195   1.4354
 -1.8466   1.4354  -0.9426
```

$K = 2 \times 3$

```
-12.1085   4.1803   5.9774
 -7.0000   8.0000  -9.0000
```

$L = 3 \times 1$

```
76.9693
 10.1191
  3.2139
```

Here, X is the unique anti-stabilizing solution, K contains the state-feedback gain and L contains the closed-loop eigenvalues.

Input Arguments

A, B, Q, R, S, E, G — Input matrices matrices

Input matrices, specified as matrices.

The matrices Q , R and G must be Hermitian. A square matrix is Hermitian if it is equal to its complex conjugate transpose, that is, $a_{i,j} = \bar{a}_{j,i}$.

For more information on Hermitian matrices, see `ishermitian`.

Matrices R and E must be invertible.

When matrices B , R , S , E and G are omitted or set to `[]`, `icare` uses the following default values:

- $B = 0$
- $R = I$
- $S = 0$
- $E = I$
- $G = 0$

If the inputs Q , R and G are scalar-valued, `icare` interprets them as multiples of the identity matrix.

'noscaling' — Option to turn off built-in scaling 'noscaling'

Option to turn off built-in scaling, specified as `'noscaling'`. When you turn off the built-in scaling, `icare` sets all entries in the scaling vectors `info.Sx` and `info.Sr` to 1. Turning off scaling speeds up computation but can be detrimental to accuracy when A, B, Q, R, S, E, G are poorly scaled.

'anti' — Option to compute the anti-stabilizing solution`'anti'`

Option to compute the anti-stabilizing solution, specified as `'anti'`. When you enable this option, `icare` computes the anti-stabilizing solution X that puts all eigenvalues of $(A+G*X*E-B*K, E)$ in the right half-plane.

The unique stabilizing and anti-stabilizing are both needed to know the complete phase portrait of the Riccati differential equations.

Output Arguments**X — Unique solution to the Riccati equation**

matrix

Unique solution to the continuous-time algebraic Riccati equation, returned as a matrix.

By default, X is the stabilizing solution of the continuous-time algebraic Riccati equation. When the `'anti'` option is used, X is the anti-stabilizing solution.

`icare` returns `[]` for X when the associated Hamiltonian matrix has eigenvalues on the imaginary axis.

K — State-feedback gain

matrix

State-feedback gain, returned as a matrix.

The state-feedback gain K is computed as:

$$K = R^{-1}(B^T X E + S^T).$$

`icare` returns `[]` for K when the associated Hamiltonian matrix has eigenvalues on the imaginary axis.

L — Closed-loop eigenvalues

matrix

Closed-loop eigenvalues, returned as a matrix.

The closed-loop eigenvalues L is computed as:

$$L = eig(A + G X E - B K, E).$$

`icare` returns `[]` for X and K when the associated Hamiltonian matrix has eigenvalues on the imaginary axis. In other words, L is non-empty even when X and K are empty matrices.

info — Information about the unique solution

structure

Information about the unique solution, returned as a structure with the following fields:

- S_x — Vector of values used to scale the states.
- S_r — Vector of values used to scale the R matrix.

- U, V and W — Vectors of values representing the basis of the stable invariant subspace of the associated scaled matrix pencil. For more information, see “Algorithms” on page 2-489.
- Report — A scalar with one of the following values:
 - 0 — The unique solution is accurate.
 - 1 — The solution accuracy is poor.
 - 2 — The solution is not finite.
 - 3 — No solution found since the Hamiltonian spectrum, denoted by $[L; -L]$, has eigenvalues on the imaginary axis.

Limitations

- $(A - sE, B)$ must be stabilizable, and E and R must be invertible for a finite stabilizing solution X to exist and be finite. While these conditions are not sufficient in general, they become sufficient when the following conditions are met:
 - $\begin{bmatrix} Q & S \\ S^T & R \end{bmatrix} \geq 0$
 - $[A - BR^{-1}S^T \quad Q - SR^{-1}S^T]$ is detectible

Algorithms

Basis of the invariant subspace

icare works with the following pencil, and computes a basis $[U;V;W]$ of the invariant subspace associated with the stable or anti-stable finite eigenvalues of this pencil.

$$M - sN = \begin{bmatrix} A & G & B \\ -Q & -A^T & -S \\ S^T & B^T & R \end{bmatrix} - s \begin{bmatrix} E & 0 & 0 \\ 0 & E^T & 0 \\ 0 & 0 & 0 \end{bmatrix}$$

The data is automatically scaled to reduce the sensitivity of eigenvalues near the imaginary axis and increase separation between the stable and anti-stable invariant subspaces.

Relationship between the solution, the state-feedback gain, and the scaling vectors

The solution X and state-feedback gain K are related to the scaling vectors, and U, V, W by the following set of equations:

$$X = D_x VU^{-1} D_x E^{-1},$$

$$K = -D_r WU^{-1} D_x,$$

where,

$$D_x = \text{diag}(S_x),$$

$$D_r = \text{diag}(S_r).$$

Basis of the invariant subspace

`icare` works with the following pencil, and computes a basis $[U;V;W]$ of the invariant subspace associated with the stable or anti-stable finite eigenvalues of this pencil.

Version History

Introduced in R2019a

See Also

`ishermitian` | `idare` | `lyap` | `lqr` | `lqg` | `kalman` | `h2syn` | `hinfsyn` | `spectralfact` | `lncf` | `rncf`

idare

Implicit solver for discrete-time algebraic Riccati equations

Syntax

```
[X,K,L] = idare(A,B,Q,R,S,E)
[X,K,L,info] = idare(____)
[____] = idare(____,'noscaling')
[____] = idare(____,'anti')
```

Description

`[X,K,L] = idare(A,B,Q,R,S,E)` computes the unique stabilizing solution X , state-feedback gain K , and the closed-loop eigenvalues L of the following discrete-time algebraic Riccati equation.

$$A^T X A - E^T X E - (A^T X B + S)(B^T X B + R)^{-1}(A^T X B + S)^T + Q = 0$$

The stabilizing solution X puts all the eigenvalues L inside the unit disk.

Algebraic Riccati equations play a key role in LQR/LQG control, H2- and H-infinity control, Kalman filtering, and spectral or co-prime factorizations.

`[X,K,L,info] = idare(____)` also returns a structure `info` which contains additional information about the solution to the discrete-time algebraic Riccati equation.

`[____] = idare(____,'noscaling')` turns off the built-in scaling and sets all entries of the scaling vectors `info.Sx` and `info.Sr` to 1. Turning off scaling speeds up computation but can be detrimental to accuracy when A, B, Q, R, S, E are poorly scaled.

`[____] = idare(____,'anti')` computes the anti-stabilizing solution X that puts all eigenvalues L outside the unit disk.

Examples

Solve Discrete-Time Algebraic Riccati Equation

For this example, solve the discrete-time algebraic Riccati equation considering the following set of matrices:

$$A = \begin{bmatrix} -0.9 & -3 \\ 0.7 & 0.1 \end{bmatrix} \quad B = \begin{bmatrix} 1 \\ 1 \end{bmatrix} \quad Q = \begin{bmatrix} 1 & 0 \\ 0 & 3 \end{bmatrix} \quad R = 0.1.$$

Find the stabilizing solution using `idare` to solve for the above matrices with default values for S and E .

```
A = [-0.9, -0.3; 0.7, 0.1];
B = [1; 1];
Q = [1, 0; 0, 3];
```

```

R = 0.1;
[X,K,L,info] = idare(A,B,Q,R,[],[])

X = 2x2

    4.7687    0.9438
    0.9438    3.2369

K = 1x2

   -0.2216   -0.1297

L = 2x1

   -0.4460
   -0.0027

info = struct with fields:
    Sx: [2x1 double]
    Sr: 1
    U: [2x2 double]
    V: [2x2 double]
    W: [-0.0232 0.0428]
    Report: 0

```

Here, X is the unique stabilizing solution, K contains the state-feedback gain, L contains the closed-loop eigenvalues, while `info` contains additional information about the solution.

Anti-Stabilizing Solution of Discrete-Time Algebraic Riccati Equation

For this example, solve the discrete-time algebraic Riccati equation considering the following set of matrices:

$$A = \begin{bmatrix} -0.9 & -3 \\ 0.7 & 0.1 \end{bmatrix} \quad B = \begin{bmatrix} 1 \\ 1 \end{bmatrix} \quad Q = \begin{bmatrix} 1 & 0 \\ 0 & 3 \end{bmatrix} \quad R = 0.1.$$

Find the anti-stabilizing solution using the 'anti' option to solve for the above matrices with default values for S and E.

```

A = [-0.9, -0.3; 0.7, 0.1];
B = [1; 1];
Q = [1, 0; 0, 3];
R = 0.1;
[X,K,L] = idare(A,B,Q,R,[],[], 'anti')

X = 2x2

   -0.5423    0.4996
    0.4996   -0.5569

```

```
K = 1x2
    -118.0177  490.9023
```

```
L = 2x1
    -371.4426
     -2.2420
```

Here, X is the unique anti-stabilizing solution, K contains the state-feedback gain, and L contains the closed-loop eigenvalues.

Input Arguments

A, B, Q, R, S, E — Input matrices

matrices

Input matrices, specified as matrices.

The matrices Q and R must be Hermitian. A square matrix is Hermitian if it is equal to its complex conjugate transpose, that is, $a_{i,j} = \bar{a}_{j,i}$.

For more information on Hermitian matrices, see `ishermitian`.

Matrix E must be non-singular.

When matrices R , S and E are omitted or set to `[]`, `idare` uses the following default values:

- $R = I$
- $S = 0$
- $E = I$

If the inputs Q and R are scalar-valued, `idare` interprets them as multiples of the identity matrix.

'noscaling' — Option to turn off built-in scaling

'noscaling'

Option to turn off built-in scaling, specified as `'noscaling'`. When you turn off the built-in scaling, `idare` sets all entries in the scaling vectors `info.Sx` and `info.Sr` to 1. Turning off scaling speeds up computation but can be detrimental to accuracy when A, B, Q, R, S, E are poorly scaled.

'anti' — Option to compute the anti-stabilizing solution

'anti'

Option to compute the anti-stabilizing solution, specified as `'anti'`. When you enable this option, `idare` computes the anti-stabilizing solution X that puts all eigenvalues of $(A - B*K, E)$ outside the unit disk.

The unique stabilizing and anti-stabilizing are both needed to know the complete phase portrait of the Riccati differential equations.

Output Arguments

X — Unique solution to the Riccati equation

matrix

Unique solution to the discrete-time algebraic Riccati equation, returned as a matrix.

By default, X is the stabilizing solution of the discrete-time algebraic Riccati equation. When the 'anti' option is used, X is the anti-stabilizing solution.

idare returns [] for X when there is no finite stabilizing solution.

K — State-feedback gain

matrix

State-feedback gain, returned as a matrix.

The state-feedback gain K is computed as:

$$K = (B^T X B + R)^{-1} (B^T X A + S^T).$$

idare returns [] for K when there is no finite stabilizing solution.

L — Closed-loop eigenvalues

matrix

Closed-loop eigenvalues, returned as a matrix.

The closed-loop eigenvalues L is computed as:

$$L = \text{eig}(A - BK, E).$$

idare returns [] for X and K when there is no finite stabilizing solution. L is non-empty even when X and K are empty matrices.

info — Information about the unique solution

structure

Information about the unique solution, returned as a structure with the following fields:

- Sx — Vector of values used to scale the states.
- Sr — Vector of values used to scale the R matrix.
- U, V and W — Vectors of values representing the basis of the stable invariant subspace of the associated scaled matrix pencil. For more information, see “Algorithms” on page 2-489.
- Report — A scalar with one of the following values:
 - 0 — The unique solution is accurate.
 - 1 — The solution accuracy is poor.
 - 2 — The solution is not finite.
 - 3 — No solution found since the Symplectic spectrum, denoted by $[L; 1./L]$, has eigenvalues on the unit circle.

Limitations

- $(A - zE, B)$ must be stabilizable, E and R must be invertible, and $[B; S; R]$ have full column rank for a finite stabilizing solution X to exist and be finite. While these conditions are not sufficient in general, they become sufficient when the following conditions are met:
 - $\begin{bmatrix} Q & S \\ S^T & R \end{bmatrix} \succeq 0$
 - $[A - BR^{-1}S^T \quad Q - SR^{-1}S^T]$ is detectible

Algorithms

Basis of the invariant subspace

idare works with the following pencil, and computes a basis $[U; V; W]$ of the invariant subspace associated with the stable or anti-stable finite eigenvalues of this pencil.

$$M - zN = \begin{bmatrix} A & 0 & B \\ -Q & E^T & -S \\ S^T & 0 & R \end{bmatrix} - z \begin{bmatrix} E & 0 & 0 \\ 0 & A^T & 0 \\ 0 & -B^T & 0 \end{bmatrix}$$

The data is automatically scaled to reduce the sensitivity of eigenvalues near the unit circle and increase separation between the stable and anti-stable invariant subspaces.

Relationship between the solution, the state-feedback gain, and the scaling vectors

The solution X and state-feedback gain K are related to the scaling vectors, and U, V, W by the following set of equations:

$$\begin{aligned} X &= D_x VU^{-1} D_x E^{-1}, \\ K &= -D_r WU^{-1} D_x, \end{aligned}$$

where,

$$\begin{aligned} D_x &= \text{diag}(S_x), \\ D_r &= \text{diag}(S_r). \end{aligned}$$

Version History

Introduced in R2019a

See Also

ishermitian | dlyap | icare | lqr | lqg | kalman | h2syn | hinfsyn | spectralfact | lncf | rncf

imp2exp

Convert implicit linear relationship to explicit input-output relation

Syntax

```
B = imp2exp(A,yidx,uidx)
B = imp2exp(A,yidx,uidx,'min')
```

Description

`B = imp2exp(A,yidx,uidx)` transforms a linear constraint between variables y and u of the form $A(:,[yidx;uidx])*[y;u] = \theta$ into an explicit input/output relationship $y = B*u$. The vectors `yidx` and `uidx` refer to the columns (inputs) of A as referenced by the explicit relationship for B .

`B = imp2exp(A,yidx,uidx,'min')` eliminates extra states to obtain a model B with as many states as A . Use this syntax when $A(:,yidx)$ has a proper inverse. This option is ignored for sparse models because it typically destroys sparsity. For `ss`, `genss` and `uss` models, B is returned in implicit form by default. Use `isproper` or `ss(sys,'explicit')` to extract an explicit model if desired.

Examples

Uncertain Matrix Algebraic Constraint

Consider two uncertain motor/generator constraints among 4 variables $\begin{bmatrix} V \\ I \\ T \\ W \end{bmatrix}$, namely

$$\begin{bmatrix} 1 & -R & 0 & -K \\ 0 & -K & 1 & 0 \end{bmatrix} * \begin{bmatrix} V \\ I \\ T \\ W \end{bmatrix} = 0. \text{ Find the uncertain 2-by-2 matrix } B \text{ so that } \begin{bmatrix} V \\ T \end{bmatrix} = B * \begin{bmatrix} W \\ I \end{bmatrix}.$$

```
R = ureal('R',1,'Percentage',[-10 40]);
K = ureal('K',2e-3,'Percentage',[-30 30]);
A = [1 -R 0 -K;0 -K 1 0];
Yidx = [1 3];
Uidx = [4 2];
B = imp2exp(A,Yidx,Uidx)
```

B =

```
Uncertain matrix with 2 rows and 2 columns.
The uncertainty consists of the following blocks:
  K: Uncertain real, nominal = 0.002, variability = [-30,30]%, 2 occurrences
  R: Uncertain real, nominal = 1, variability = [-10,40]%, 1 occurrences
```

Type "B.NominalValue" to see the nominal value, "get(B)" to see all properties, and "B.Uncertain"

Scalar Dynamic System Constraint

Consider a standard single-loop feedback connection of controller C and an uncertain plant P, described by the equations $e = r - y$; $u = Ce$; $f = d + u$; $y = Pf$.

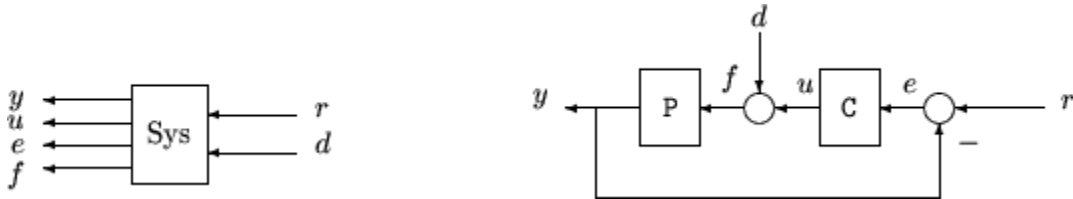

```
P = tf([1],[1 0]);
C = tf([2*.707*1 1^2],[1 0]);
A = [1 -1 0 0 0 -1;0 -C 1 0 0 0;0 0 -1 -1 1 0;0 0 0 0 -P 1];
OutputIndex = [6;3;2;5]; % [y;u;e;f]
InputIndex = [1;4]; % [r;d]
Sys = imp2exp(A,OutputIndex,InputIndex);
Sys.InputName = {'r';'d'};
Sys.OutputName = {'y';'u';'e';'f'};
```

```
pole(Sys)
```

```
ans = 14x1 complex
```

```
-0.7070 + 0.7072i
-0.7070 - 0.7072i
-0.7070 + 0.7072i
-0.7070 - 0.7072i
-0.7070 + 0.7072i
-0.7070 - 0.7072i
-0.7070 + 0.7072i
-0.7070 - 0.7072i
-0.7070 + 0.7072i
-0.7070 - 0.7072i
⋮
```

```
stepplot(Sys)
```

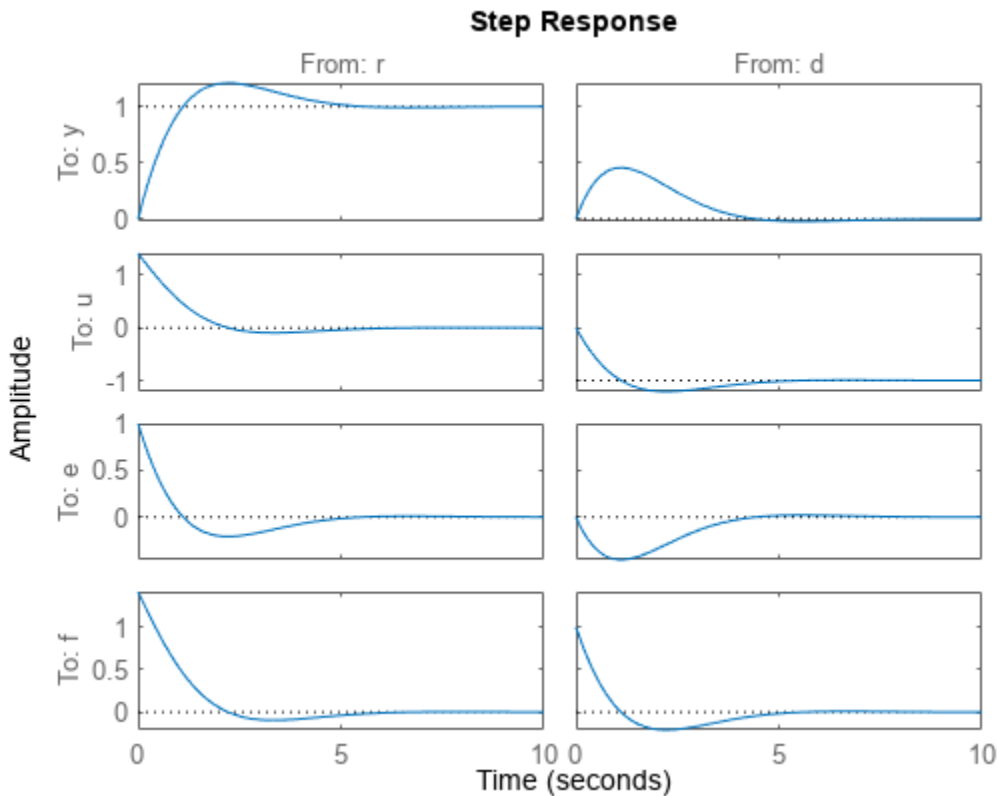

Input Arguments

A — Implicit system

static or dynamic input/output model

Implicit system, specified as a static, or dynamic input/output model. A can be:

- A numeric LTI model such as `tf`, `zpk`, `ss`, or `frd` object
- An uncertain model such as `umat`, `uss`, or `ufrd` object

The number of rows in model A must equal the length of the index vector `yidx`.

`yidx` — Indices to partition implicit model channels into output signals

vector

Indices to partition the model channel into output signals, specified as a vector. The index vectors `yidx` and `uidx` specify how to partition the input channels of A into y and u signals, respectively.

If [`yidx`,`uidx`] does not include all inputs of A, `imp2exp` excludes the missing y channels from the output model B. In such cases, `imp2exp` retains only a subset `B(I, :)` of the outputs/rows of B and does not affect how the explicit model B is computed.

`uidx` — Indices to partition implicit model channels into input signals

vector

Indices to partition the model channel into input signals, specified as a vector. The index vectors `yidx` and `uidx` specify how to partition the input channels of `A` into `y` and `u` signals, respectively.

Output Arguments

B — Explicit system

static or dynamic input/output model

Explicit system, returned as a static, or dynamic input/output model. The output explicit model `B` is of the same subclass as model `A`. For instance, if `A` is specified as an `ss` model, then `imp2exp` also returns `B` as an `ss` model.

Version History

Introduced in R2011b

See Also

`connect` | `inv`

impulse

Impulse response plot of dynamic system; impulse response data

Syntax

```
impulse(sys)
impulse(sys,tFinal)
impulse(sys,t)
impulse(sys1,sys2,...,sysN,___)
impulse(sys1,LineStyle1,...,sysN,LineStyleN,___)
```

```
y = impulse(sys,t)
[y,tOut] = impulse(sys)
[y,tOut] = impulse(sys,tFinal)
[y,t,x] = impulse(sys)
[y,t,x,ysd] = impulse(sys)
```

Description

Impulse Response Plots

`impulse(sys)` plots the response of a dynamic system model to an impulse input. The model `sys` can be continuous or discrete.

- For continuous-time `sys`, the impulse input is the Dirac impulse $\delta(t)$. For continuous-time `sys` with direct feedthrough, `impulse` ignores the infinite pulse at $t = 0$.
- For discrete-time `sys` with sample time T_s , the function computes the response to a unit-area pulse of length T_s and height $1/T_s$. This pulse approaches the continuous-time Dirac impulse $\delta(t)$ as T_s goes to zero.

`sys` can be SISO or MIMO. For MIMO systems, the plot displays the impulse responses for each I/O channel. `impulse` automatically determines the time steps and duration of the simulation based on the system dynamics.

`impulse(sys,tFinal)` simulates the impulse response from $t = 0$ to the final time $t = tFinal$. The function uses system dynamics to determine the intervening time steps.

`impulse(sys,t)` plots the impulse response at the times that you specify in the vector `t`.

`impulse(sys1,sys2,...,sysN,___)` plots the impulse response of multiple dynamic systems on the same plot. All systems must have the same number of inputs and outputs. You can use multiple dynamic systems with any of the previous input-argument combinations.

`impulse(sys1,LineStyle1,...,sysN,LineStyleN,___)` specifies a color, line style, and marker for each system in the plot. You can use `LineStyle` with any of the previous input-argument combinations. When you need additional plot customization options, use `impulseplot` instead.

Impulse Response Data

`y = impulse(sys,t)` returns the impulse response `sys` at the times specified in the vector `t`. This syntax does not draw a plot.

`[y,tOut] = impulse(sys)` also returns a vector of times `tOut` corresponding to the responses in `y`. If you do not provide an input vector `t` of times, `impulse` chooses the length and time step of `tOut` based on the system dynamics.

`[y,tOut] = impulse(sys,tFinal)` computes the impulse response up to the end time `tFinal`. `impulse` chooses the time step of `tOut` based on the system dynamics.

`[y,t,x] = impulse(sys)` also returns the state trajectories `x`, when `sys` is a state-space model such as an `ss` or `idss` model.

`[y,t,x,ysd] = impulse(sys)` also computes the standard deviation `ysd` of the impulse response `y`, when `sys` is an identified model such as an `idss`, `idtf`, or `idnlarx` model.

Examples

Impulse Response of Dynamic System

Plot the impulse response of a continuous-time system represented by the following transfer function.

$$\text{sys}(s) = \frac{4}{s^2 + 2s + 10}$$

For this example, create a `tf` model that represents the transfer function. You can similarly plot the impulse response of other dynamic system model types, such as zero-pole gain (`zpk`) or state-space (`ss`) models.

```
sys = tf(4,[1 2 10]);
```

Plot the impulse response.

```
impulse(sys)
```

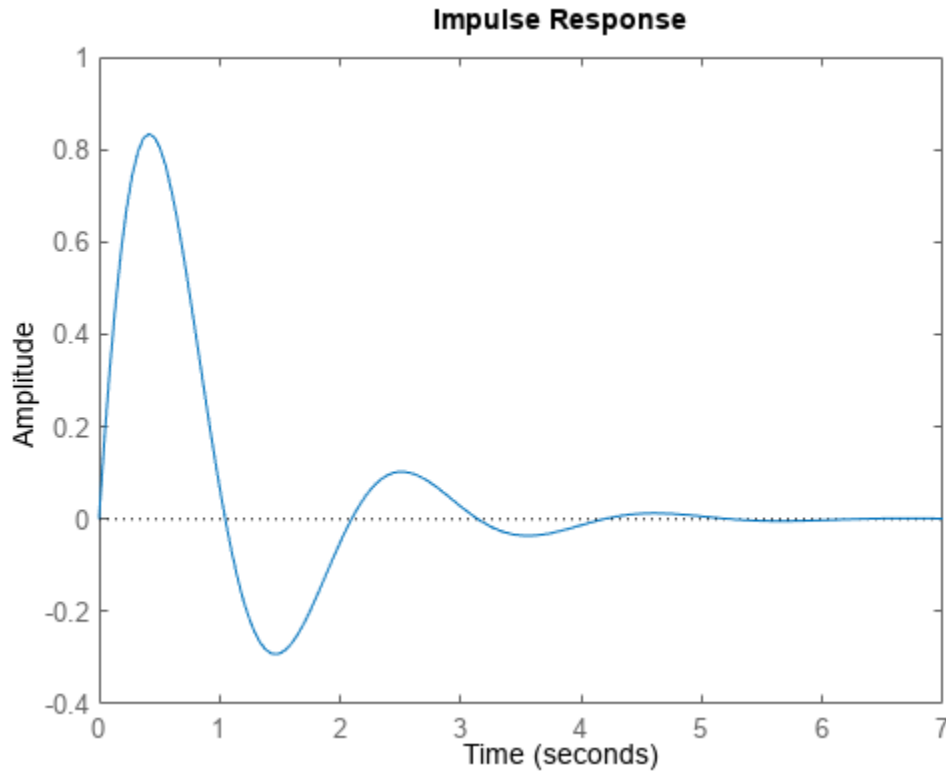

The impulse plot automatically includes a dotted horizontal line indicating the steady-state response. In a MATLAB® figure window, you can right-click on the plot to view other impulse-response characteristics such as peak response and transient time.

Impulse Response of Discrete-Time System

Plot the impulse response of a discrete-time system. The system has a sample time of 0.2 s and is represented by the following state-space matrices.

```
A = [1.6 -0.7;  
      1  0];  
B = [0.5; 0];  
C = [0.1 0.1];  
D = 0;
```

Create the state-space model and plot its impulse response.

```
sys = ss(A,B,C,D,0.2);  
impz(sys)
```

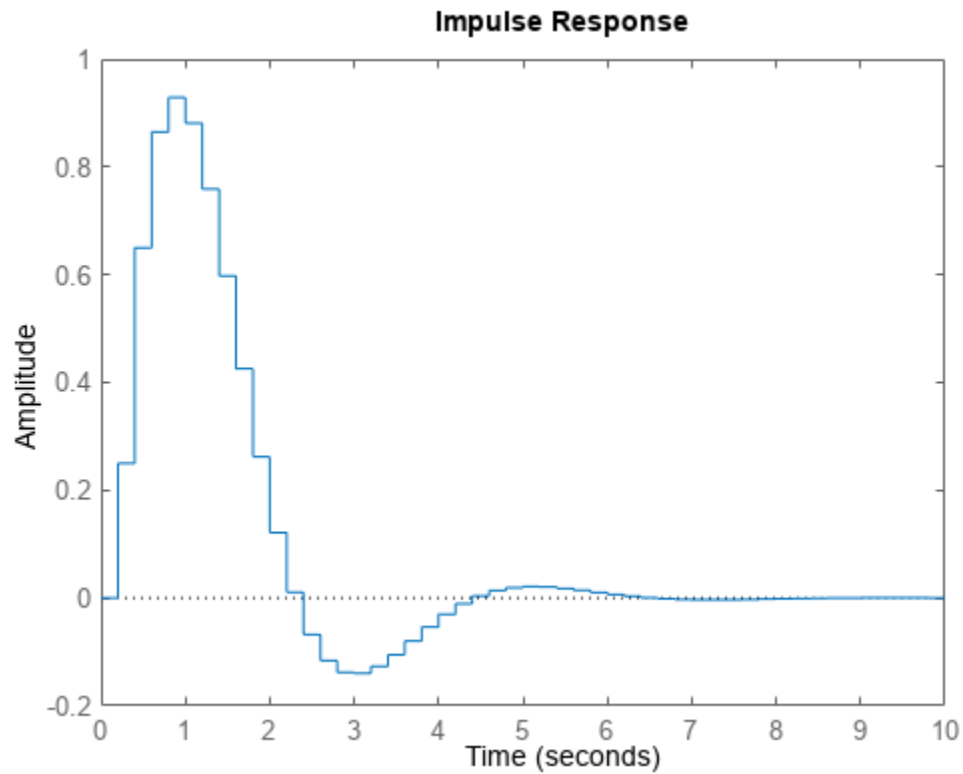
The impulse response reflects the discretization of the model, as it shows the response as computed every 0.2 seconds.

Impulse Response at Specified Times

Examine the impulse response of the following zero-pole-gain model.

```
sys = zpk(-1,[-0.2+3j,-0.2-3j],1) * tf([1 1],[1 0.05])
```

```
sys =
```

$$\frac{(s+1)^2}{(s+0.05)(s^2 + 0.4s + 9.04)}$$

Continuous-time zero/pole/gain model.

```
impulse(sys)
```

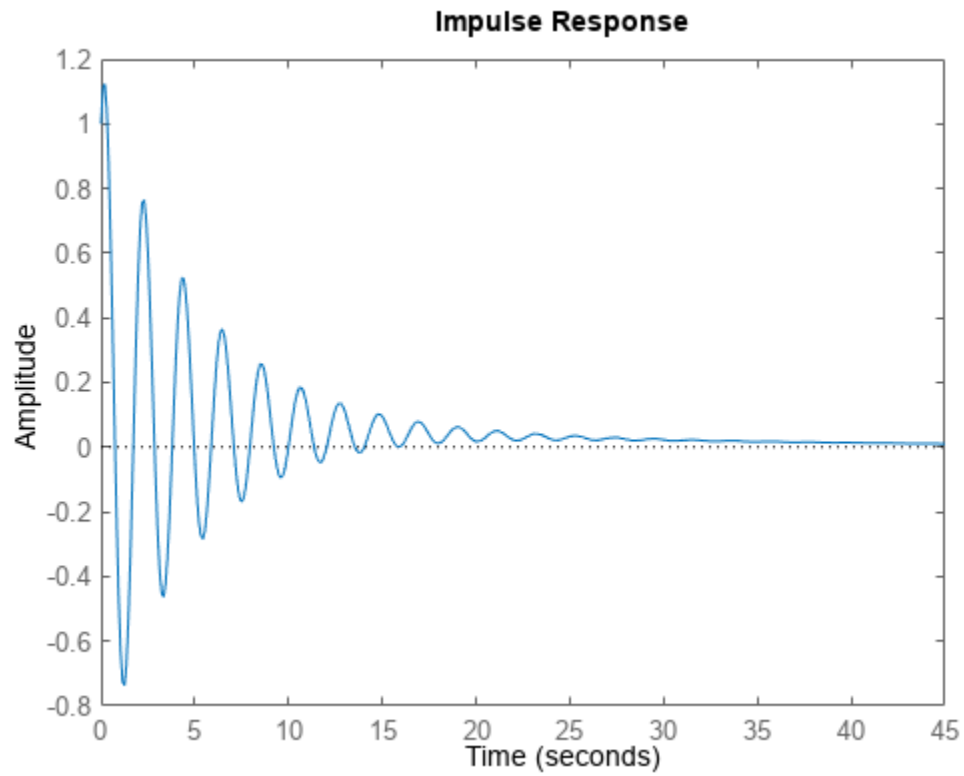

By default, `impulse` chooses an end time that shows the steady state that the response is trending toward. To get a closer look at the transient response, limit the impulse plot to $t = 20$ s.

```
impulse(sys,20)
```

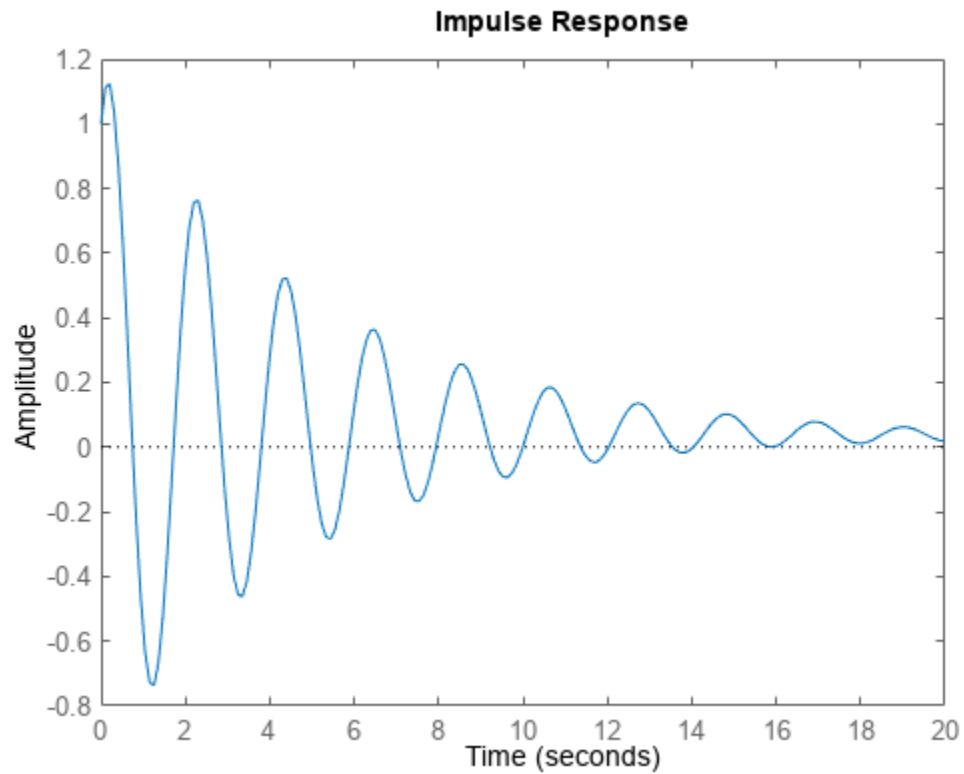

Alternatively, you can specify the exact times at which you want to examine the impulse response, provided they are separated by a constant interval. For instance, examine the response from the end of the transient until the system reaches steady state.

```
t = 20:0.2:120;  
impulse(sys,t)
```

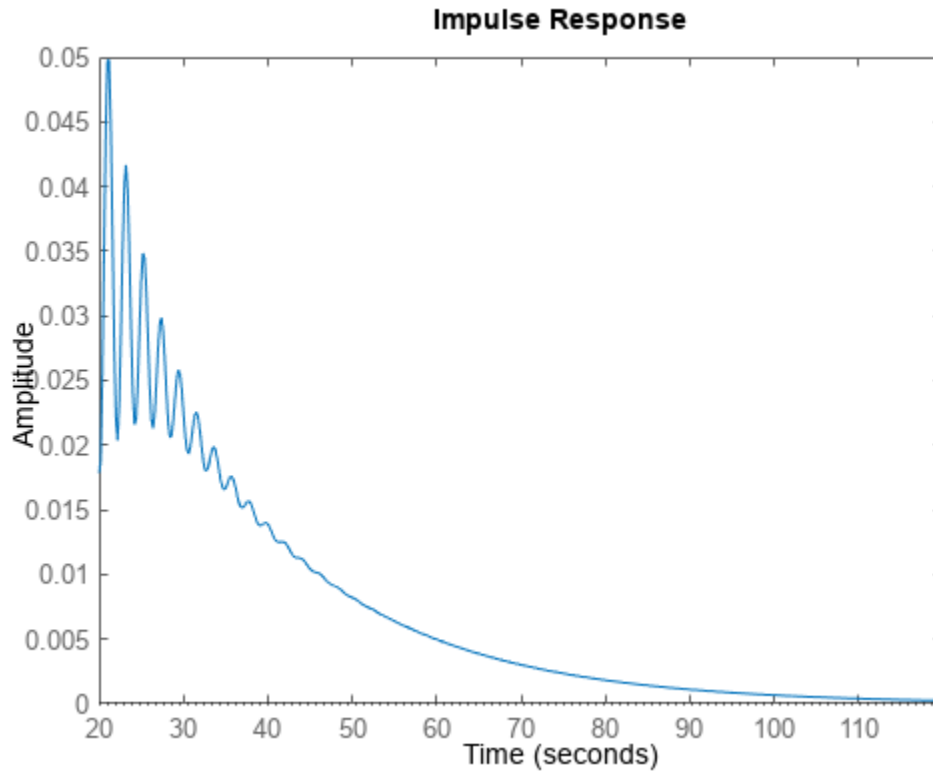

Even though this plot begins at $t = 20$, `impz` always applies the impulse input at $t = 0$.

Impulse Response Plot of MIMO Systems

Consider the following second-order state-space model:

$$\begin{bmatrix} \dot{x}_1 \\ \dot{x}_2 \end{bmatrix} = \begin{bmatrix} -0.5572 & -0.7814 \\ 0.7814 & 0 \end{bmatrix} \begin{bmatrix} x_1 \\ x_2 \end{bmatrix} + \begin{bmatrix} 1 & -1 \\ 0 & 2 \end{bmatrix} \begin{bmatrix} u_1 \\ u_2 \end{bmatrix}$$

$$y = [1.9691 \ 6.4493] \begin{bmatrix} x_1 \\ x_2 \end{bmatrix}$$

```
A = [-0.5572, -0.7814; 0.7814, 0];
```

```
B = [1, -1; 0, 2];
```

```
C = [1.9691, 6.4493];
```

```
sys = ss(A, B, C, 0);
```

This model has two inputs and one output, so it has two channels: from the first input to the output and from the second input to the output. Each channel has its own impulse response.

When you use `impz`, it computes the responses of all channels.

```
impz(sys)
```

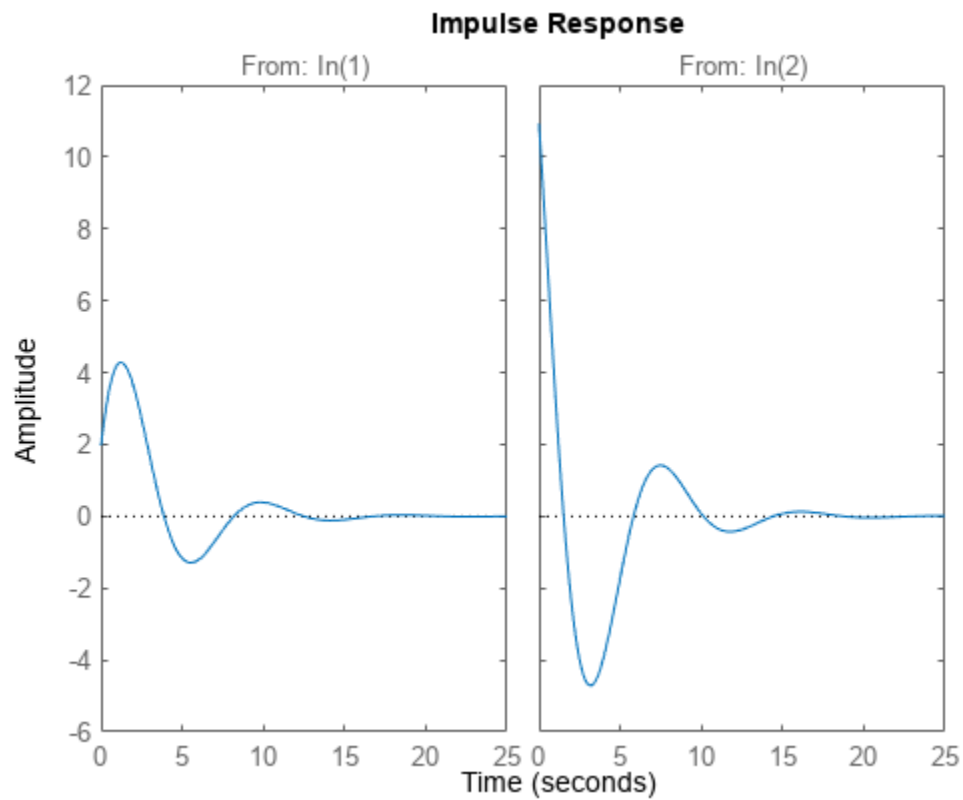

The left plot shows the impulse response of the first input channel, and the right plot shows the impulse response of the second input channel. Whenever you use `impulse` to plot the responses of a MIMO model, it generates an array of plots representing all the I/O channels of the model. For instance, create a random state-space model with five states, three inputs, and two outputs, and plot its impulse response.

```
sys = rss(5,2,3);  
impulse(sys)
```

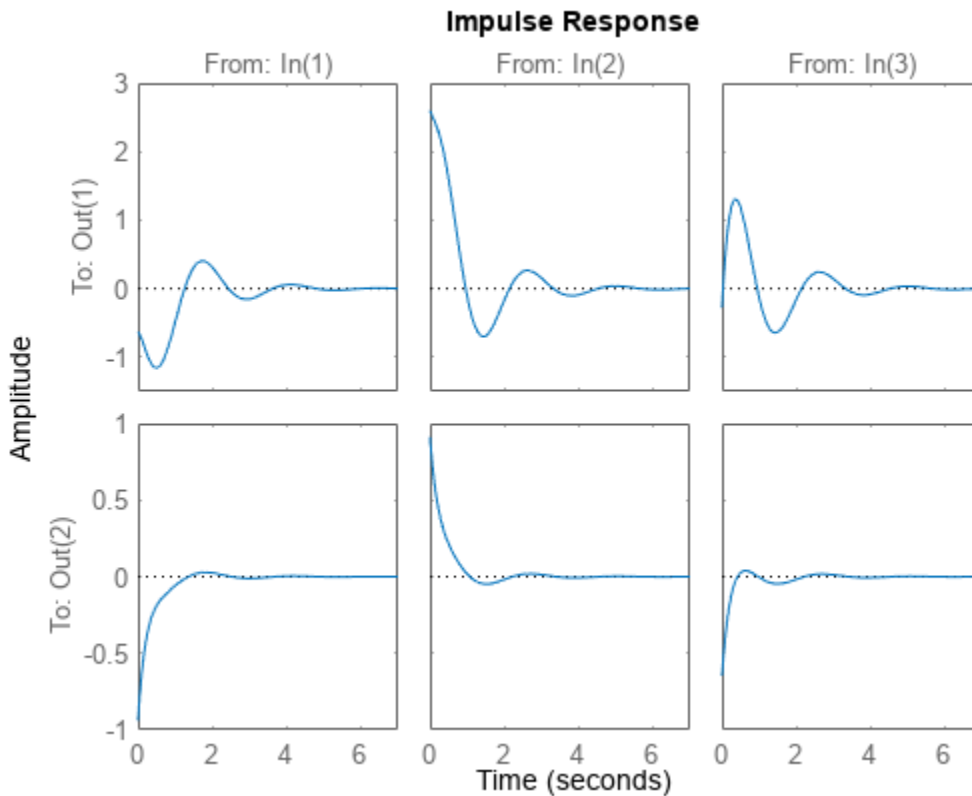

In a MATLAB figure window, you can restrict the plot to a subset of channels by right-clicking on the plot and selecting **I/O Selector**.

Compare Impulse Response of Multiple Systems

`impz` allows you to plot the responses of multiple dynamic systems on the same axis. For instance, compare the closed-loop response of a system with a PI controller and a PID controller. Create a transfer function of the system and tune the controllers.

```
H = tf(4,[1 2 10]);
C1 = pidtune(H,'PI');
C2 = pidtune(H,'PID');
```

Form the closed-loop systems and plot their impulse responses.

```
sys1 = feedback(H*C1,1);
sys2 = feedback(H*C2,1);
impz(sys1,sys2)
legend('PI','PID','Location','SouthEast')
```

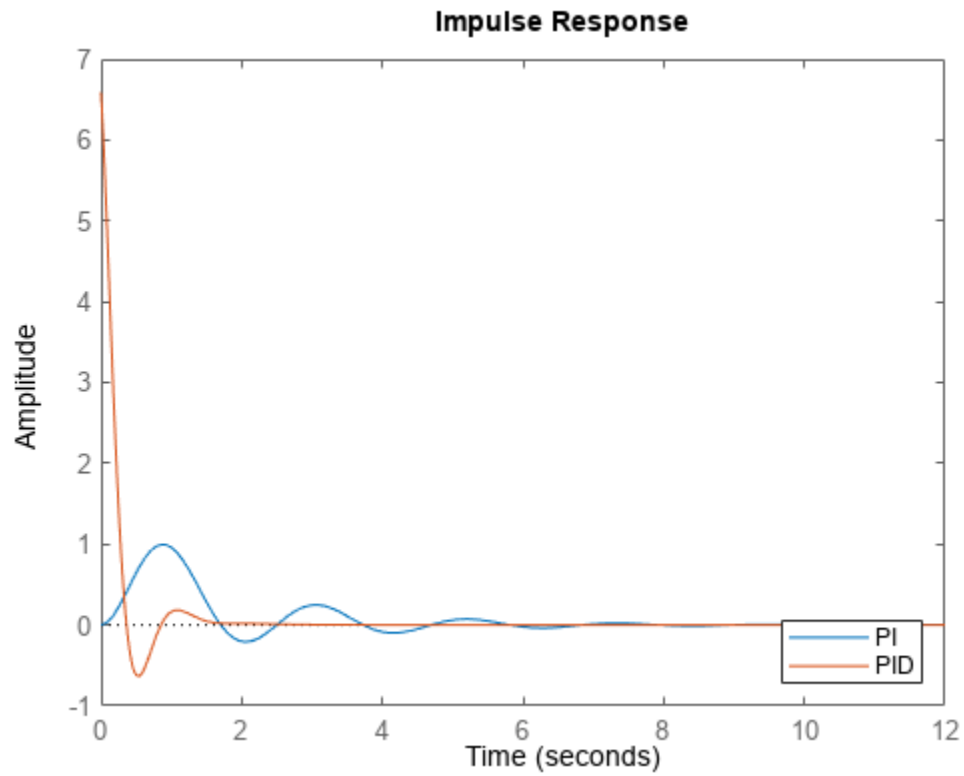

By default, `impulse` chooses distinct colors for each system that you plot. You can specify colors and line styles using the `LineStyle` input argument.

```
impulse(sys1, 'r--', sys2, 'b')  
legend('PI', 'PID', 'Location', 'SouthEast')
```

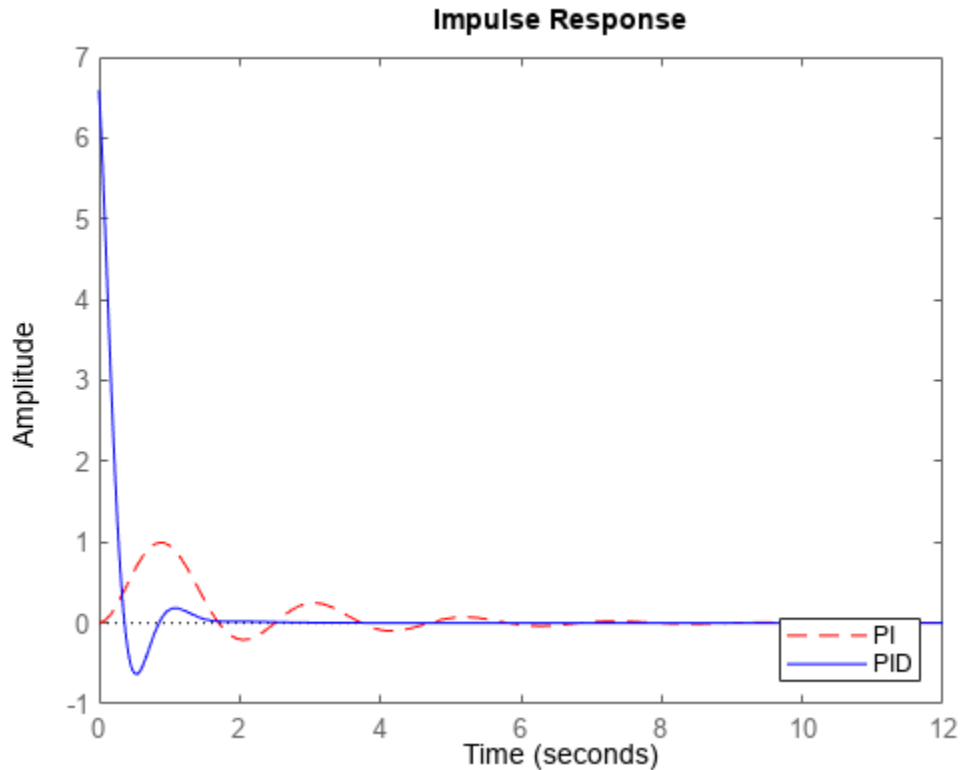

The first LineSpec 'r--' specifies a dashed red line for the response with the PI controller. The second LineSpec 'b' specifies a solid blue line for the response with the PID controller. The legend reflects the specified colors and linestyles. For more plot customization options, use `impzplot`.

Impulse Response of Systems in a Model Array

The example **Compare Impulse Response of Multiple Systems** shows how to plot responses of several individual systems on a single axis. When you have multiple dynamic systems arranged in a model array, `impz` plots all their responses at once.

Create a model array. For this example, use a one-dimensional array of second-order transfer functions having different natural frequencies. First, preallocate memory for the model array. The following command creates a 1-by-5 row of zero-gain SISO transfer functions. The first two dimensions represent the model outputs and inputs. The remaining dimensions are the array dimensions.

```
sys = tf(zeros(1,1,1,5));
```

Populate the array.

```
w0 = 1.5:1:5.5;    % natural frequencies
zeta = 0.5;        % damping constant
for i = 1:length(w0)
```



```

sys(:,:,1,i) = tf(w0(i)^2,[1 2*zeta*w0(i) w0(i)^2]);
end

```

(For more information about model arrays and how to create them, see “Model Arrays”.) Plot the impulse responses of all models in the array.

```
impulse(sys)
```

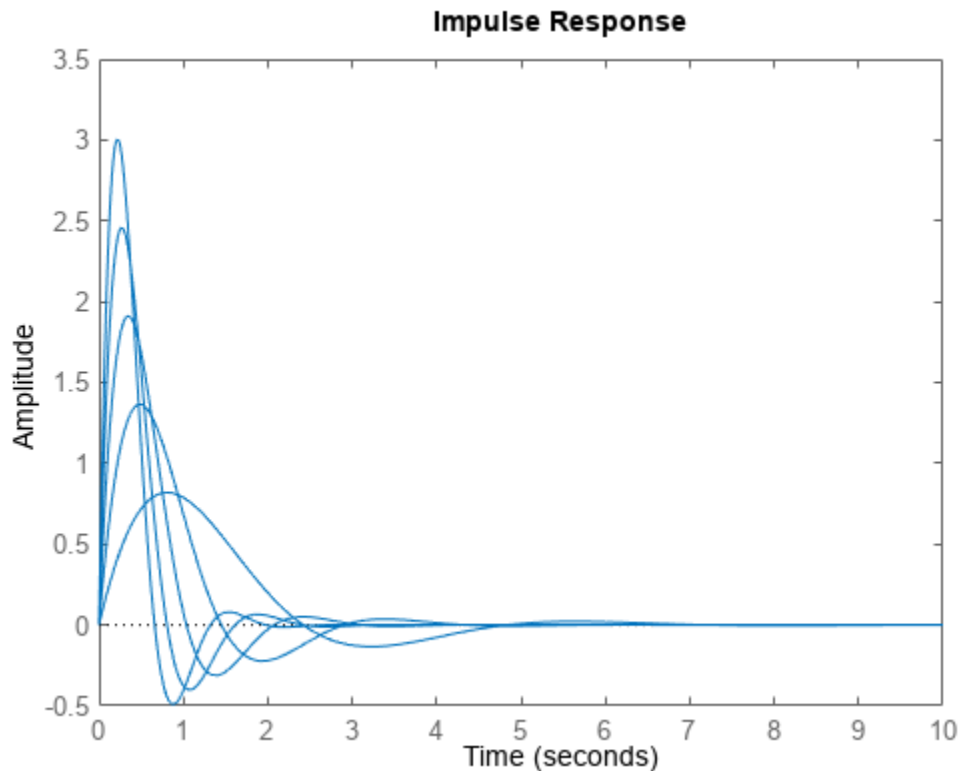

`impulse` uses the same linestyle for the responses of all entries in the array. One way to distinguish among entries is to use the `SamplingGrid` property of dynamic system models to associate each entry in the array with the corresponding w_0 value.

```
sys.SamplingGrid = struct('frequency',w0);
```

Now, when you plot the responses in a MATLAB figure window, you can click a trace to see which frequency value it corresponds to.

Impulse Response Data

When you give it an output argument, `impulse` returns an array of response data. For a SISO system, the response data is returned as a column vector of length equal to the number of time points at which the response is sampled. You can provide the vector `t` of time points, or allow `impulse` to select time points for you based on system dynamics. For instance, extract the impulse response of a SISO system at 101 time points between $t = 0$ and $t = 5$ s.

```
sys = tf(4,[1 2 10]);  
t = 0:0.05:5;  
y = impulse(sys,t);  
size(y)
```

```
ans = 1×2  
  
101    1
```

For a MIMO system, the response data is returned in an array of dimensions N -by- N_y -by- N_u , where N_y and N_u are the number of outputs and inputs of the dynamic system. For instance, consider the following state-space model, representing a two-input, one-output system.

```
A = [-0.5572, -0.7814;0.7814, 0];  
B = [1, -1;0, 2];  
C = [1.9691, 6.4493];  
sys = ss(A,B,C,0);
```

Extract the impulse response of this system at 200 time points between $t = 0$ and $t = 20$ s.

```
t = linspace(0,20,200);  
y = impulse(sys,t);  
size(y)
```

```
ans = 1×3  
  
200    1    2
```

$y(:, i, j)$ is a column vector containing the impulse response from the j th input to the i th output at the times t . For instance, extract the impulse response from the second input to the output.

```
y12 = y(:, 1, 2);  
plot(t,y12)
```

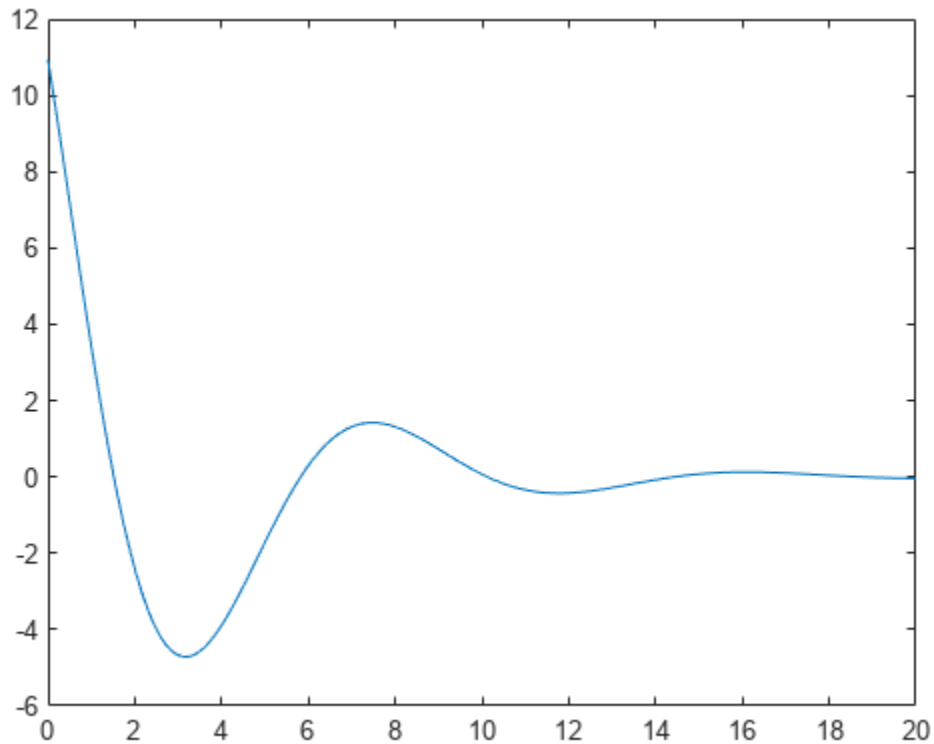

Impulse Responses of Identified Models with Confidence Regions

Compare the impulse response of a parametric identified model to a non-parametric (empirical) model. Also view their 3σ confidence regions.

Load the data.

```
load iddata1 z1
```

Estimate a parametric model.

```
sys1 = ssest(z1,4);
```

Estimate a non-parametric model.

```
sys2 = impulseest(z1);
```

Plot the impulse responses for comparison.

```
t = (0:0.1:10)';
[y1, ~, ~, ysd1] = impulse(sys1,t);
[y2, ~, ~, ysd2] = impulse(sys2,t);
plot(t, y1, 'b', t, y1+3*ysd1, 'b:', t, y1-3*ysd1, 'b:')
hold on
plot(t, y2, 'g', t, y2+3*ysd2, 'g:', t, y2-3*ysd2, 'g:')
```

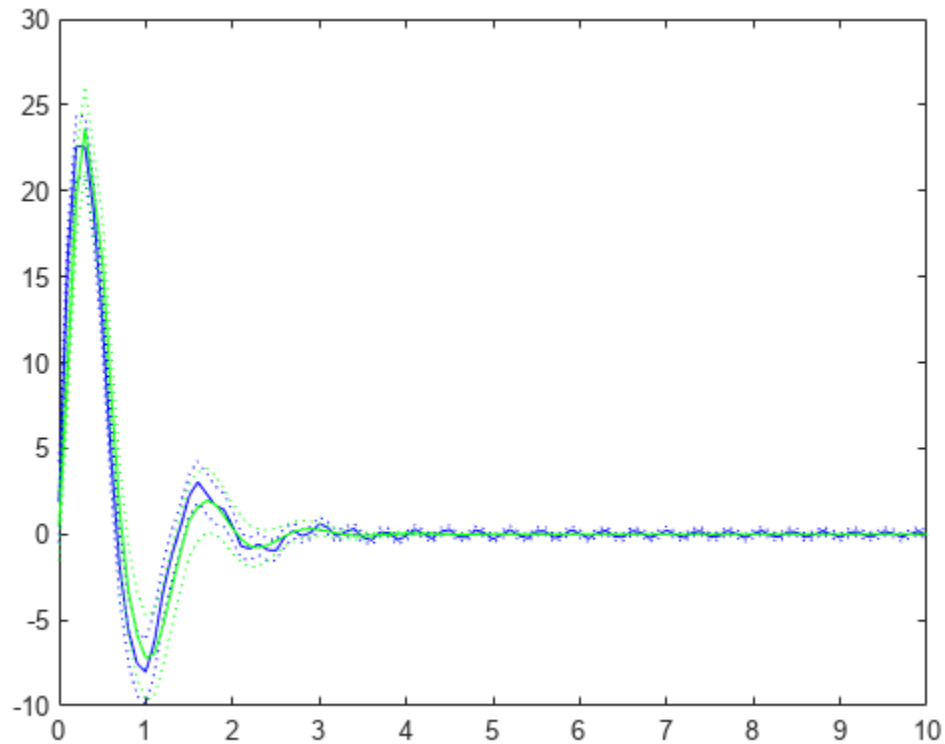

Impulse Response of Identified Time-Series Model

Compute the impulse response of an identified time-series model.

A time-series model, also called a signal model, is one without measured input signals. The impulse plot of this model uses its (unmeasured) noise channel as the input channel to which the impulse signal is applied.

Load the data.

```
load iddata9;
```

Estimate a time-series model.

```
sys = ar(z9, 4);
```

`sys` is a model of the form $A y(t) = e(t)$, where $e(t)$ represents the noise channel. For computation of impulse response, $e(t)$ is treated as an input channel, and is named `e@y1`.

Plot the impulse response.

```
impulse(sys)
```

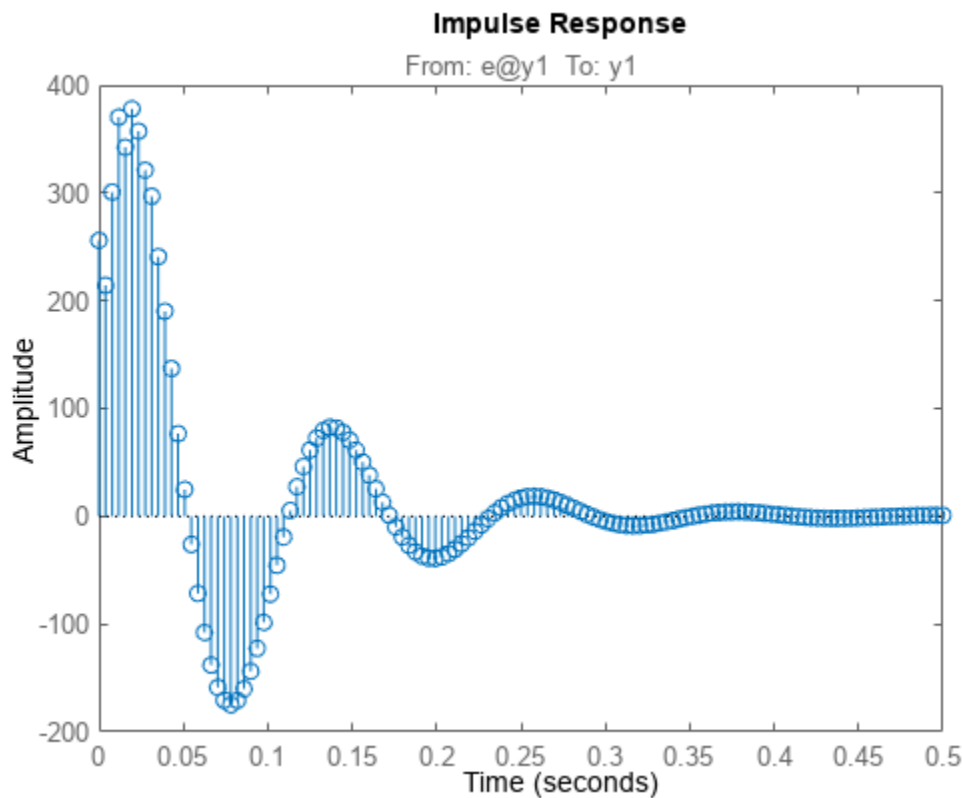

Input Arguments

sys — Dynamic system

dynamic system model | model array

Dynamic system, specified as a SISO or MIMO dynamic system model or array of dynamic system models. Dynamic systems that you can use include:

- Continuous-time or discrete-time numeric LTI models, such as `tf`, `zpk`, or `ss` models.
- Generalized or uncertain LTI models such as `genss` or `uss` models. (Using uncertain models requires Robust Control Toolbox software.)
 - For tunable control design blocks, the function evaluates the model at its current value for both plotting and returning response data.
 - For uncertain control design blocks, the function plots the nominal value and random samples of the model. When you use output arguments, the function returns response data for the nominal model only.
- Sparse state-space models such as `sparss` and `mehss` models. You must specify final time `tFinal` for sparse state-space models.
- Identified LTI models, such as `idtf`, `idss`, or `idproc` models. For such models, the function can also plot confidence intervals and return standard deviations of the frequency response. (Using identified models requires System Identification Toolbox software.)

`impulse` does not support frequency-response data models such as `frd`, `genfrd`, or `idfrd` models.

If `sys` is an array of models, the function plots the responses of all models in the array on the same axes.

tFinal — End time for impulse response

positive scalar

End time for impulse response, specified as a positive scalar value. `impulse` simulates the impulse response from $t = 0$ to $t = tFinal$.

- For continuous-time systems, the function determines the step size and number of points automatically from system dynamics. Express `tFinal` in the system time units, specified in the `TimeUnit` property of `sys`.
- For discrete-time systems, the function uses the sample time of `sys` as the step size. Express `tFinal` in the system time units, specified in the `TimeUnit` property of `sys`.
- For discrete-time systems with unspecified sample time ($T_s = -1$), `impulse` interprets `tFinal` as the number of sampling periods to simulate.

t — Time vector

vector

Time vector at which to compute the impulse response, specified as a vector of positive scalar values. Express `t` in the system time units, specified in the `TimeUnit` property of `sys`.

- For continuous-time models, specify `t` in the form `Ti:dt:Tf`. To obtain the response at each time step, the function uses `dt` as the sample time of a discrete approximation to the continuous system.
- For discrete-time models, specify `t` in the form `Ti:T_s:Tf`, where `T_s` is the sample time of `sys`.

`impulse` always applies the impulse input at $t = 0$, regardless of `Ti`.

LineStyle — Line style, marker, and color

character vector | string

Line style, marker, and color, specified as a string or vector of one, two, or three characters. The characters can appear in any order. You do not need to specify all three characteristics (line style, marker, and color). For example, if you omit the line style and specify the marker, then the plot shows only the marker and no line. For more information about configuring this argument, see the `LineStyle` input argument of the `plot` function.

Example: `'r--'` specifies a red dashed line

Example: `'*b'` specifies blue asterisk markers

Example: `'y'` specifies a yellow line

Output Arguments

y — Impulse response data

array

Impulse response data, returned as an array.

- For SISO systems, y is a column vector of the same length as t (if provided) or $tOut$ (if you do not provide t).
- For single-input, multi-output systems, y is a matrix with as many rows as time samples and as many columns as outputs. Thus, the j th column of y , or $y(:, j)$, contains the impulse response of from the input to the j th output.
- For MIMO systems, the impulse responses of each input channel are stacked up along the third dimension of y . The dimensions of y are then N -by- N_y -by- N_u , where:
 - N is the number of time samples.
 - N_y is the number of system outputs.
 - N_u is the number of system inputs.

Thus, $y(:, i, j)$ is a column vector containing the impulse response from the j th input to the i th output at the times specified in t or $tOut$.

tOut — Times at which impulse response is computed

vector

Times at which impulse response is computed, returned as a vector. When you do not provide a specific vector t of times, `impulse` chooses this time vector based on the system dynamics. The times are expressed in the time units of `sys`.

x — State trajectories

array

State trajectories, returned as an array. When `sys` is a state-space model, x contains the evolution of the states of `sys` at each time in t or $tOut$. The dimensions of x are N -by- N_x -by- N_u , where:

- N is the number of time samples.
- N_x is the number of states.
- N_u is the number of system inputs.

Thus, the evolution of the states in response to an impulse injected at the k th input is given by the array $x(:, :, k)$. The row vector $x(i, :, k)$ contains the state values at the i th time step.

ysd — Standard deviation of impulse response

array

Standard deviation of the impulse response of an identified model, returned as an array of the same dimensions as y . If `sys` does not contain parameter covariance information, then `ysd` is empty.

Limitations

- The impulse response of a continuous system with nonzero D matrix is infinite at $t = 0$. `impulse` ignores this discontinuity and returns the lower continuity value Cb at $t = 0$.
- The `impulse` command does not work on continuous-time models with internal delays. For such models, use `pade` to approximate the time delay before computing the impulse response.

Tips

- When you need additional plot customization options, use `impzplot` instead.

- To simulate system responses to arbitrary input signals, use `lsim`.

Algorithms

Continuous-time models are first converted to state-space form. The impulse response of a single-input state-space model

$$\begin{aligned}\dot{x} &= Ax + bu \\ y &= Cx\end{aligned}$$

is equivalent to the following unforced response with initial state b .

$$\begin{aligned}\dot{x} &= Ax, \quad x(0) = b \\ y &= Cx\end{aligned}$$

To simulate this response, the system is discretized using zero-order hold on the inputs. The sample time is chosen automatically based on the system dynamics, except when a time vector $t = 0:dt:Tf$ is supplied. Hence, `dt` is used as sample time.

Version History

Introduced before R2006a

See Also

Linear System Analyzer | `step` | `initial` | `lsim` | `pade` | `impz`

impulseplot

Plot impulse response with additional plot customization options

Syntax

```
h = impulseplot(sys)
h = impulseplot(sys1,sys2,...,sysN)
h = impulseplot(sys1,LineStyle1,...,sysN,LineStyleN)
h = impulseplot( ___,tFinal)
h = impulseplot( ___,t)
h = impulseplot(AX, ___)
h = impulseplot( ___,plotoptions)
```

Description

`impulseplot` lets you plot dynamic system impulse responses with a broader range of plot customization options than `impulse`. You can use `impulseplot` to obtain the plot handle and use it to customize the plot, such as modify the axes labels, limits and units. You can also use `impulseplot` to draw an impulse response plot on an existing set of axes represented by an axes handle. To customize an existing impulse plot using the plot handle:

- 1 Obtain the plot handle
- 2 Use `getoptions` to obtain the option set
- 3 Update the plot using `setoptions` to modify the required options

For more information, see “Customizing Response Plots from the Command Line”. To create impulse plots with default options or to extract impulse response data, use `impulse`.

`h = impulseplot(sys)` plots the impulse response of the dynamic system model `sys` and returns the plot handle `h` to the plot. You can use this handle `h` to customize the plot with the `getoptions` and `setoptions` commands.

`h = impulseplot(sys1,sys2,...,sysN)` plots the impulse response of multiple dynamic systems `sys1,sys2,...,sysN` on the same plot. All systems must have the same number of inputs and outputs to use this syntax.

`h = impulseplot(sys1,LineStyle1,...,sysN,LineStyleN)` sets the line style, marker type, and color for the impulse response of each system. All systems must have the same number of inputs and outputs to use this syntax.

`h = impulseplot(___,tFinal)` simulates the impulse response from $t = 0$ to the final time $t = tFinal$. Specify `tFinal` in the system time units, specified in the `TimeUnit` property of `sys`. For discrete-time systems with unspecified sample time ($T_s = -1$), `impulseplot` interprets `tFinal` as the number of sampling intervals to simulate.

`h = impulseplot(___,t)` simulates the impulse response using the time vector `t`. Specify `t` in the system time units, specified in the `TimeUnit` property of `sys`.

`h = impulseplot(AX, ___)` plots the impulse response on the Axes object in the current figure with the handle `AX`.

`h = impulseplot(___,plotoptions)` plots the impulse response with the options set specified in `plotoptions`. You can use these options to customize the impulse plot appearance using the command line. Settings you specify in `plotoptions` overrides the preference settings in the MATLAB session in which you run `impzplot`. Therefore, this syntax is useful when you want to write a script to generate multiple plots that look the same regardless of the local preferences.

Examples

Customize Impulse Plot using Plot Handle

For this example, use the plot handle to change the time units to minutes and turn on the grid.

Generate a random state-space model with 5 states and create the impulse response plot with plot handle `h`.

```
rng("default")
sys = rss(5);
h = impulseplot(sys);
```

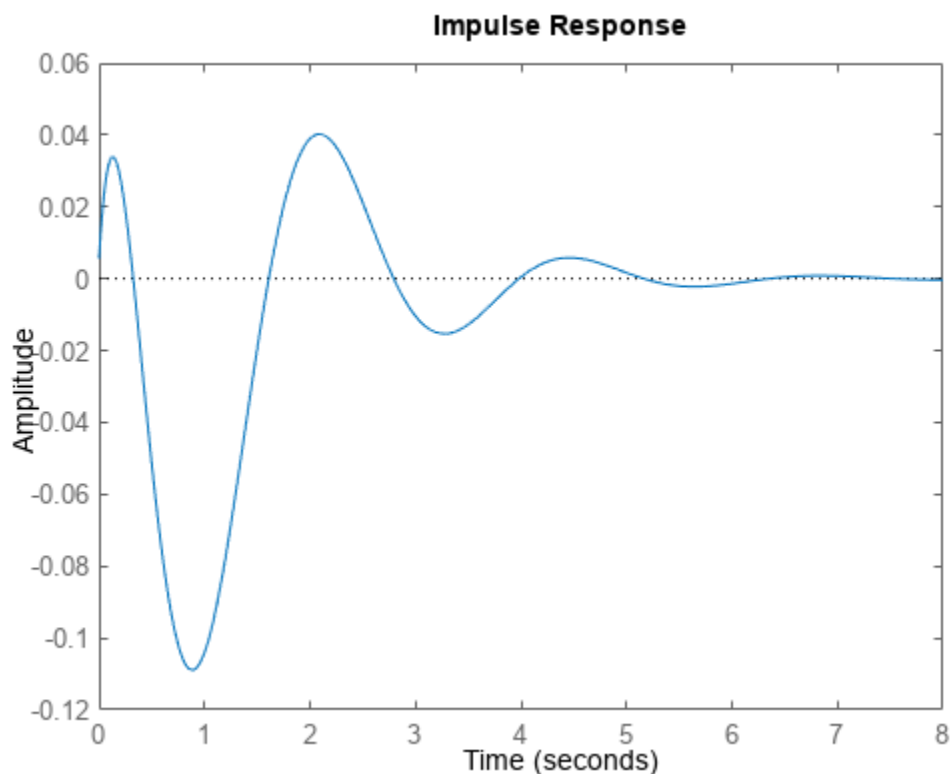

Change the time units to minutes and turn on the grid. To do so, edit properties of the plot handle, `h` using `setoptions`.

```
setoptions(h,'TimeUnits','minutes','Grid','on');
```

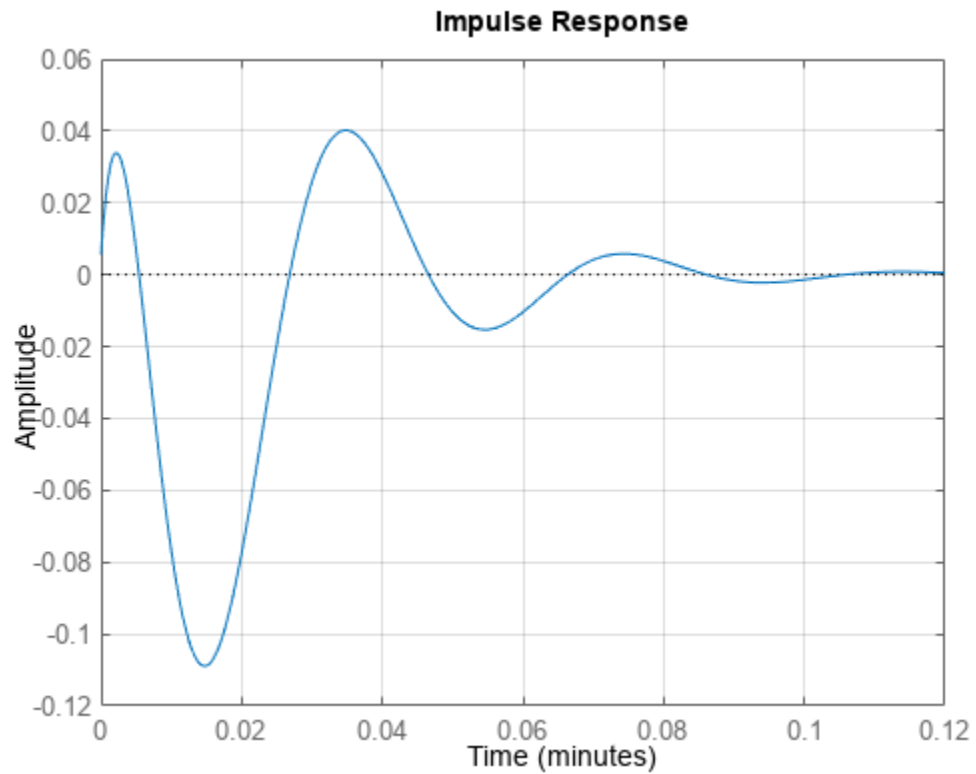

The impulse plot automatically updates when you call `setoptions`.

Alternatively, you can also use the `timeoptions` command to specify the required plot options. First, create an options set based on the toolbox preferences.

```
plotoptions = timeoptions('cstprefs');
```

Change properties of the options set by setting the time units to minutes and enabling the grid.

```
plotoptions.TimeUnits = 'minutes';  
plotoptions.Grid = 'on';  
impzplot(sys,plotoptions);
```

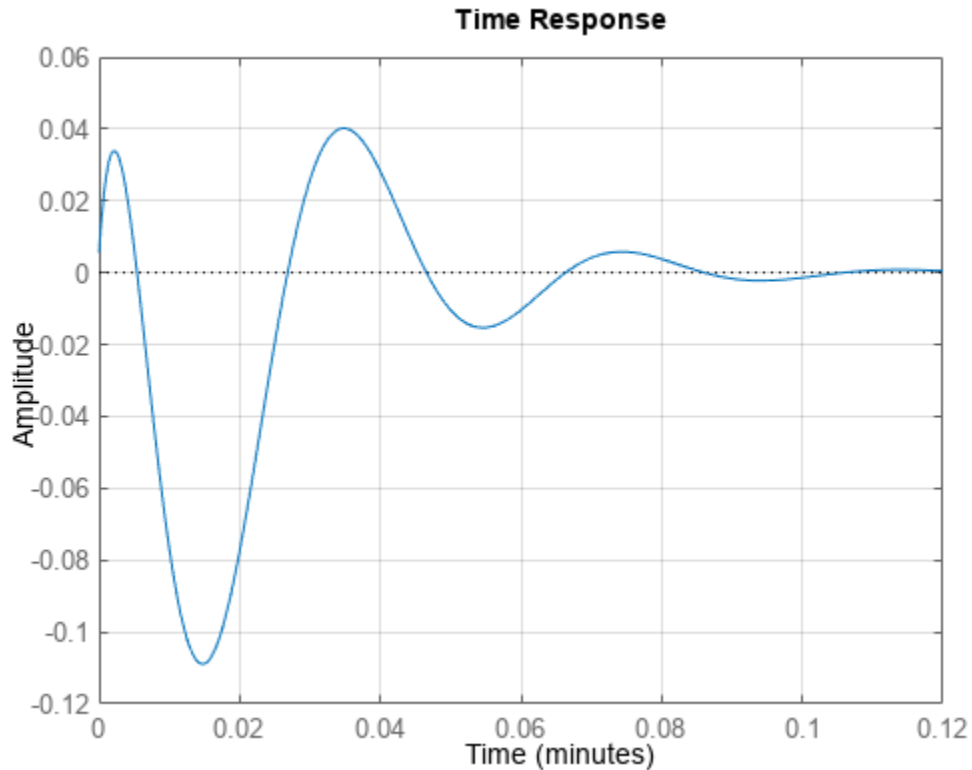

You can use the same option set to create multiple impulse plots with the same customization. Depending on your own toolbox preferences, the plot you obtain might look different from this plot. Only the properties that you set explicitly, in this example `TimeUnits` and `Grid`, override the toolbox preferences.

Impulse Plot with Specified Grid Color

For this example, consider a MIMO state-space model with 3 inputs, 3 outputs and 3 states. Create a impulse plot with red colored grid lines.

Create the MIMO state-space model `sys_mimo`.

```
J = [8 -3 -3; -3 8 -3; -3 -3 8];
F = 0.2*eye(3);
A = -J\F;
B = inv(J);
C = eye(3);
D = 0;
sys_mimo = ss(A,B,C,D);
size(sys_mimo)
```

State-space model with 3 outputs, 3 inputs, and 3 states.

Create an impulse plot with plot handle `h` and use `getoptions` for a list of the options available.

```
h = impulseplot(sys_mimo)
```

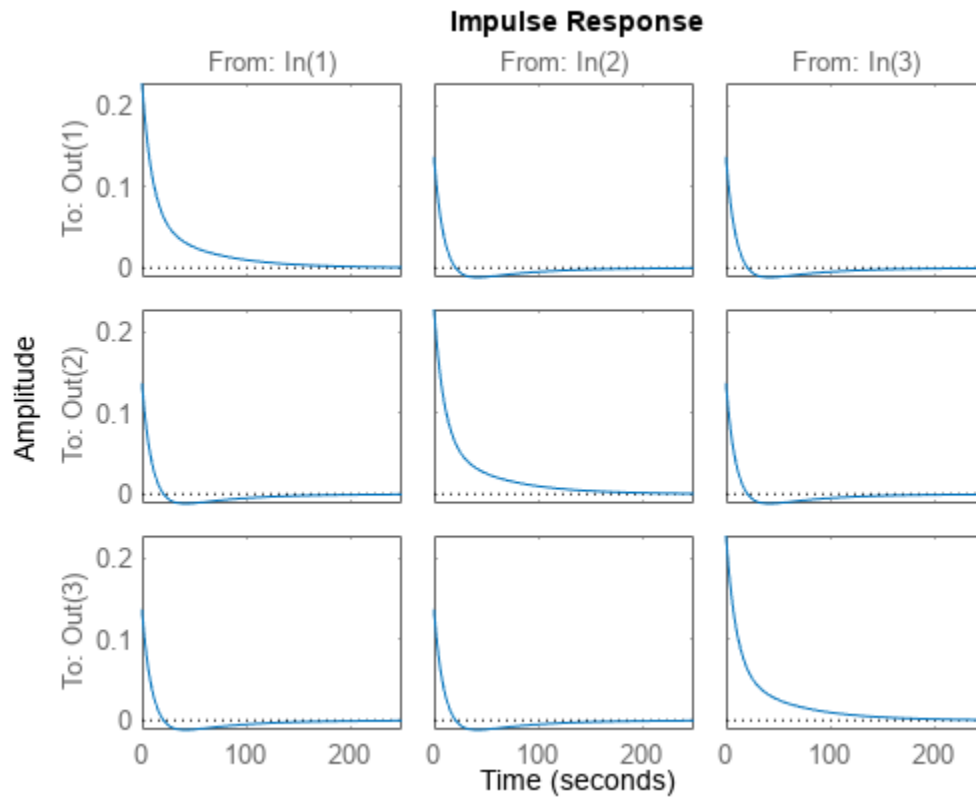

```
h =
```

```
respack.timeplot
```

```
p = getoptions(h)
```

```
p =
```

```

        Normalize: 'off'
    SettleTimeThreshold: 0.0200
        RiseTimeLimits: [0.1000 0.9000]
            TimeUnits: 'seconds'
ConfidenceRegionNumberSD: 1
        IOGrouping: 'none'
        InputLabels: [1x1 struct]
        OutputLabels: [1x1 struct]
        InputVisible: {3x1 cell}
        OutputVisible: {3x1 cell}
            Title: [1x1 struct]
            XLabel: [1x1 struct]
            YLabel: [1x1 struct]
        TickLabel: [1x1 struct]
            Grid: 'off'
        GridColor: [0.1500 0.1500 0.1500]
            XLim: {3x1 cell}
            YLim: {3x1 cell}

```

```
XLimMode: {3x1 cell}
YLimMode: {3x1 cell}
```

Use `setoptions` to update the plot with the required customization.

```
setoptions(h, 'Grid', 'on', 'GridColor', [1 0 0]);
```

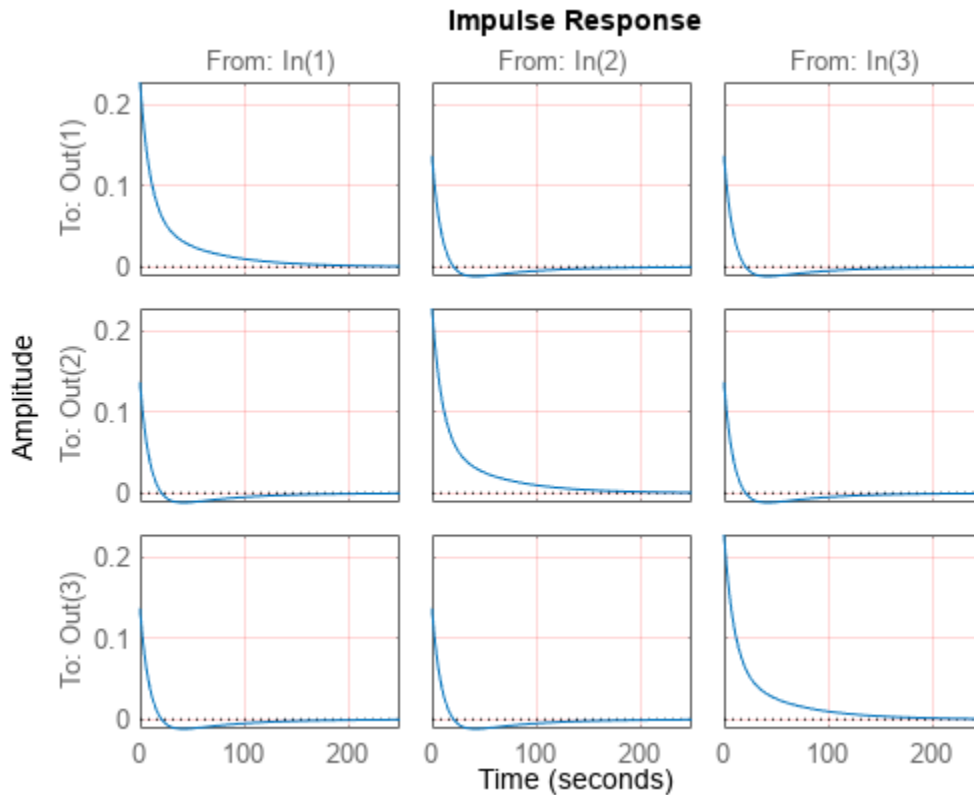

The impulse plot automatically updates when you call `setoptions`. For MIMO models, `impzplot` produces a grid of plots, each plot displaying the impulse response of one I/O pair.

Plot Impulse Responses of Identified Models with Confidence Region

Compare the impulse response of a parametric identified model to a nonparametric (empirical) model, and view their 3- σ confidence regions. (Identified models require System Identification Toolbox™ software.)

Identify a parametric and a nonparametric model from sample data.

```
load iddata1 z1
sys1 = ssest(z1,4);
sys2 = impulseest(z1);
```

Plot the impulse responses of both identified models. Use the plot handle to display the 3- σ confidence regions.

```
t = -1:0.1:5;
h = impulseplot(sys1, 'r', sys2, 'b', t);
showConfidence(h, 3)
legend('parametric', 'nonparametric')
```

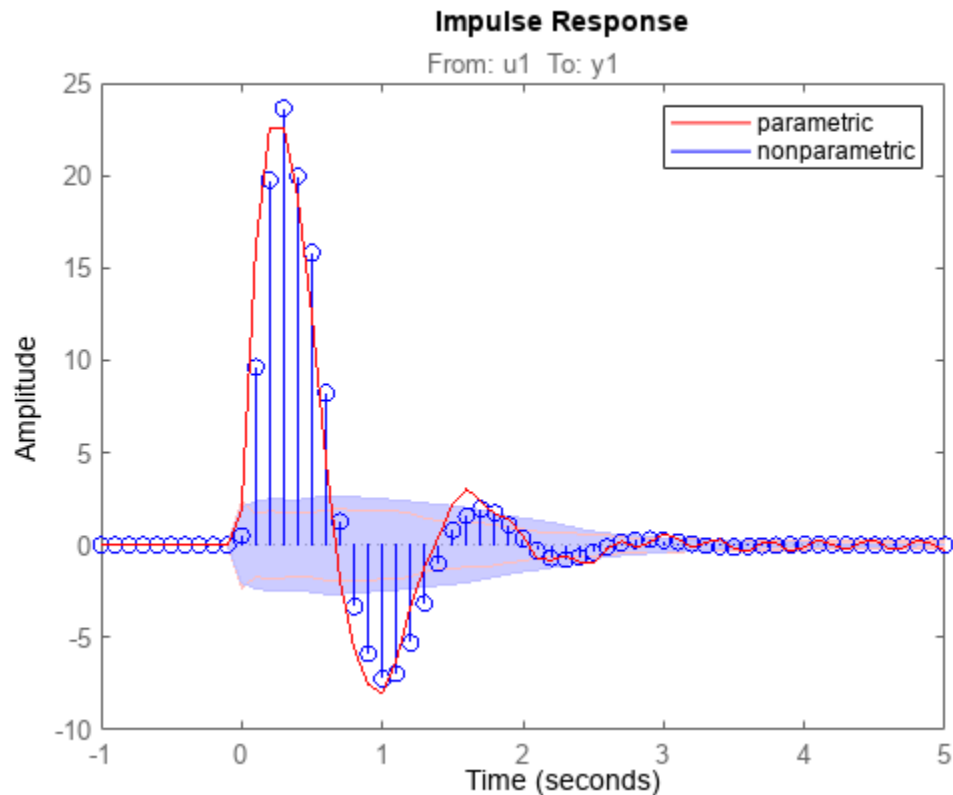

The nonparametric model sys2 shows higher uncertainty.

Customized Impulse Response Plot at Specified Time

For this example, examine the impulse response of the following zero-pole-gain model and limit the impulse plot to $t_{\text{Final}} = 15$ s. Use 15-point blue text for the title. This plot should look the same, regardless of the preferences of the MATLAB session in which it is generated.

```
sys = zpk(-1, [-0.2+3j, -0.2-3j], 1)*tf([1 1], [1 0.05]);
tFinal = 15;
```

First, create a default options set using `timeoptions`.

```
plotoptions = timeoptions;
```

Next change the required properties of the options set `plotoptions`.

```
plotoptions.Title.FontSize = 15;
plotoptions.Title.Color = [0 0 1];
```

Now, create the impulse response plot using the options set `plotoptions`.

```
h = impulseplot(sys,tFinal,plotoptions);
```

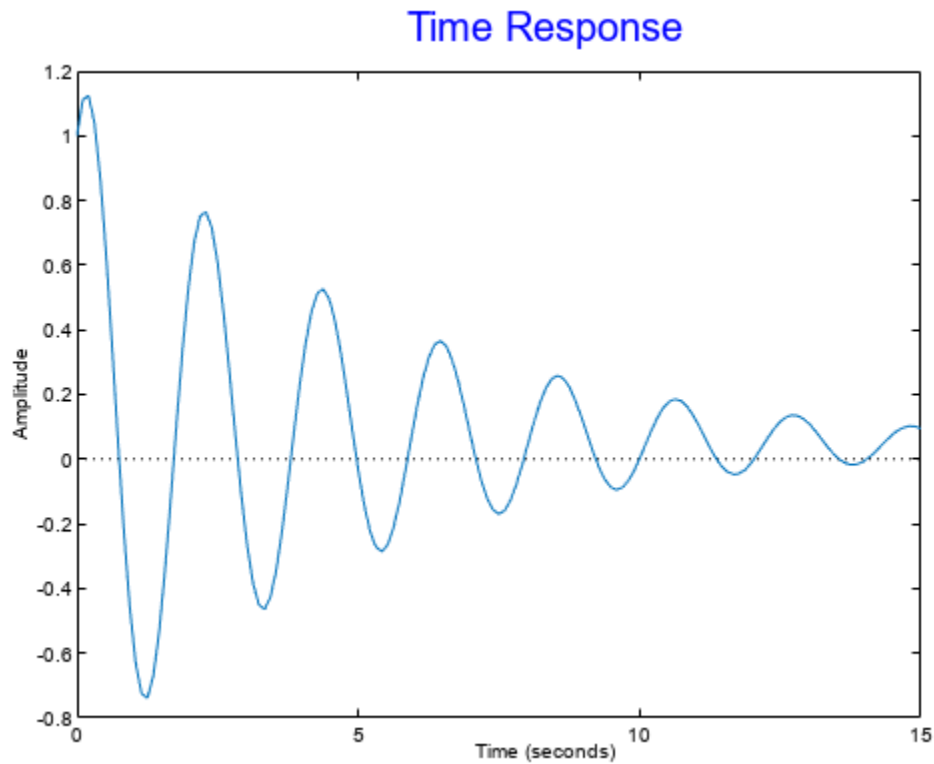

Because `plotoptions` begins with a fixed set of options, the plot result is independent of the toolbox preferences of the MATLAB session.

Input Arguments

sys — Dynamic system

dynamic system model | model array

Dynamic system, specified as a SISO or MIMO dynamic system model or array of dynamic system models. Dynamic systems that you can use include:

- Continuous-time or discrete-time numeric LTI models, such as `tf`, `zpk`, or `ss` models.
- Sparse state-space models, such as `sparss` or `mechss` models. Final time `tFinal` must be specified when using sparse models.
- Generalized or uncertain LTI models such as `genss` or `uss` models. (Using uncertain models requires Robust Control Toolbox software.)
- For tunable control design blocks, the function evaluates the model at its current value to plot the impulse response data.

- For uncertain control design blocks, the function plots the nominal value and random samples of the model.
- Identified LTI models, such as `idtf`, `idss`, or `idproc` models. (Using identified models requires System Identification Toolbox software.)

If `sys` is an array of models, the function plots the impulse response of all models in the array on the same axes.

LineStyleSpec – Line style, marker, and color

character vector | string

Line style, marker, and color, specified as a character vector or string containing symbols. The symbols can appear in any order. You do not need to specify all three characteristics (line style, marker, and color). For example, if you omit the line style and specify the marker, then the plot shows only the marker and no line.

Example: `'--or'` is a red dashed line with circle markers

Line Style	Description
-	Solid line
--	Dashed line
:	Dotted line
-. .	Dash-dot line

Marker	Description
'o'	Circle
'+'	Plus sign
'*'	Asterisk
'.'	Point
'x'	Cross
'_'	Horizontal line
' '	Vertical line
's'	Square
'd'	Diamond
'^'	Upward-pointing triangle
'v'	Downward-pointing triangle
'>'	Right-pointing triangle
'<'	Left-pointing triangle
'p'	Pentagram
'h'	Hexagram

Color	Description
y	yellow
m	magenta

Color	Description
c	cyan
r	red
g	green
b	blue
w	white
k	black

tFinal – Final time for impulse response computation

scalar

Final time for impulse response computation, specified as a scalar. Specify **tFinal** in the system time units, specified in the `TimeUnit` property of `sys`. For discrete-time systems with unspecified sample time ($T_s = -1$), `impzplot` interprets **tFinal** as the number of sampling intervals to simulate.

t – Time for impulse response simulation

vector

Time for impulse response simulation, specified as a vector. Specify the time vector **t** in the system time units, specified in the `TimeUnit` property of `sys`. The time vector must be real, finite, and must contain monotonically increasing and evenly spaced time samples.

The time vector **t** is:

- $t = T_{initial}:T_{sample}:T_{final}$, for discrete-time systems.
- $t = T_{initial}:dt:T_{final}$, for continuous-time systems. Here, dt is the sample time of a discrete approximation of the continuous-time system.

AX – Target axes

Axes object

Target axes, specified as an Axes object. If you do not specify the axes and if the current axes are Cartesian axes, then `impzplot` plots on the current axes. Use **AX** to plot into specific axes when creating a impulse plot.

plotoptions – Impulse plot options set

`TimePlotOptions` object

Impulse plot options set, specified as a `TimePlotOptions` object. You can use this option set to customize the impulse plot appearance. Use `timeoptions` to create the option set. Settings you specify in `plotoptions` overrides the preference settings in the MATLAB session in which you run `impzplot`. Therefore, `plotoptions` is useful when you want to write a script to generate multiple plots that look the same regardless of the local preferences.

For the list of available options, see `timeoptions`.

Output Arguments

h – Plot handle

handle object

Plot handle, returned as a `handle` object. Use the handle `h` to get and set the properties of the impulse plot using `getoptions` and `setoptions`. For the list of available options, see the *Properties and Values Reference* section in “Customizing Response Plots from the Command Line”.

Version History

Introduced before R2006a

See Also

`getoptions` | `impulse` | `setoptions`

Topics

“Customizing Response Plots from the Command Line”

initial

System response to initial states of state-space model

Syntax

```
initial(sys,x0)
initial(sys,x0,tFinal)
initial(sys,x0,t)
initial(sys1,sys2,...,sysN,x0,___)
initial(sys1,LineStyle1,...,sysN,LineStyleN,x0,___)

[y,tOut,x] = initial(sys,x0)
[y,tOut,x] = initial(sys,x0,___)
```

Description

Initial Response Plots

`initial(sys,x0)` plots the unforced system response to initial states of a state-space (ss) model `sys` with an initial condition on the states specified by the vector `x0`:

$$\dot{x} = Ax, \quad x(0) = x_0$$

$$y = Cx$$

The state-space model `sys` can be continuous-time or discrete-time, and SISO or MIMO. For MIMO state-space systems, the plot displays the responses for the outputs of each channel. `initial` automatically determines the time steps and duration of the simulation based on the system dynamics.

`initial(sys,x0,tFinal)` plots the simulated response from $t = 0$ to the final time $t = tFinal$. The function uses system dynamics to determine the intervening time steps.

`initial(sys,x0,t)` plots the response at the times that you specify in the vector `t`.

`initial(sys1,sys2,...,sysN,x0,___)` plots the response of multiple dynamic systems on the same plot. All systems must have the same number of inputs and outputs. You can use multiple dynamic systems with any of the previous input-argument combinations.

`initial(sys1,LineStyle1,...,sysN,LineStyleN,x0,___)` specifies a color, line style, and marker for each system in the response plot. You can use `LineStyle` with any of the previous input-argument combinations. When you need additional plot customization options, use `initialplot` instead.

Initial Response Data

`[y,tOut,x] = initial(sys,x0)` returns the output response `y`, the time vector `tOut` and the state trajectories `x`. The array `y` has as many rows as time samples (length of `tOut`) and as many columns as outputs. Similarly, `x` has `length(tOut)` rows and as many columns as states.

`[y,tOut,x] = initial(sys,x0,___)` also uses response time specified as `t` or `tFinal` to return the response data.

Examples

Initial Conditions Response Plot

For this example, generate a random state-space model with 5 states and create the plot for the system response to the initial states.

```
rng("default")
sys = rss(5);
x0 = [1,2,3,4,5];
initial(sys,x0)
```

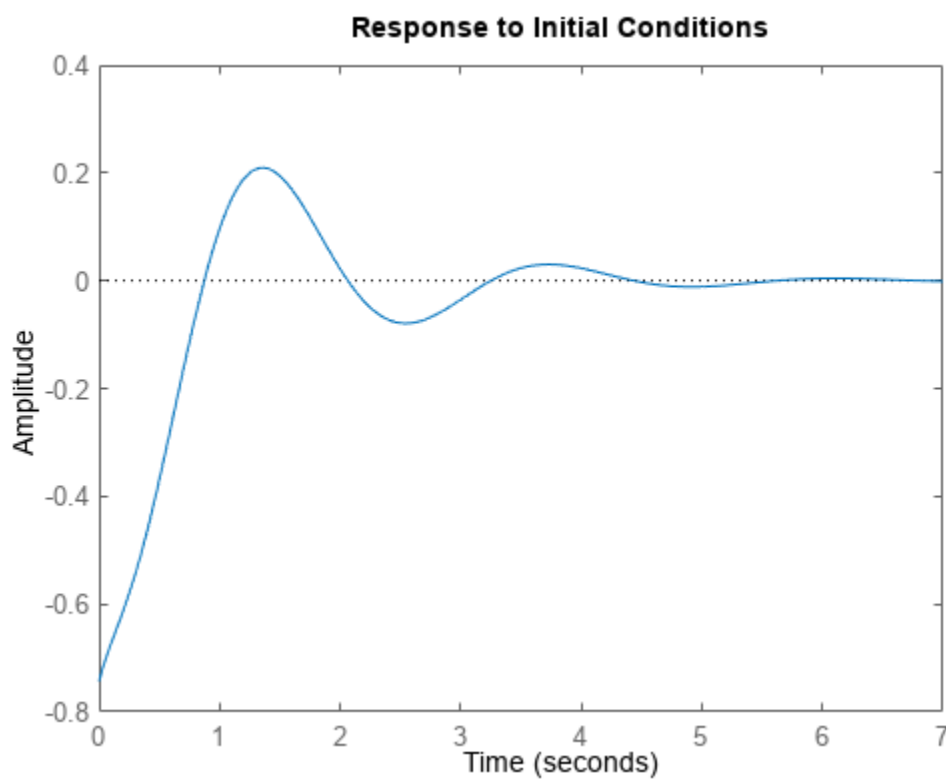

Response of State-Space Model to Initial Condition

Plot the response of the following state-space model:

$$\begin{bmatrix} \dot{x}_1 \\ \dot{x}_2 \end{bmatrix} = \begin{bmatrix} -0.5572 & -0.7814 \\ 0.7814 & 0 \end{bmatrix} \begin{bmatrix} x_1 \\ x_2 \end{bmatrix}$$

$$y = [1.9691 \quad 6.4493] \begin{bmatrix} x_1 \\ x_2 \end{bmatrix}.$$

Take the following initial condition:

$$x(0) = \begin{bmatrix} 1 \\ 0 \end{bmatrix}.$$

```
a = [-0.5572, -0.7814; 0.7814, 0];
```

```
c = [1.9691 6.4493];
```

```
x0 = [1 ; 0];
```

```
sys = ss(a,[],c,[]);
```

```
initial(sys,x0)
```

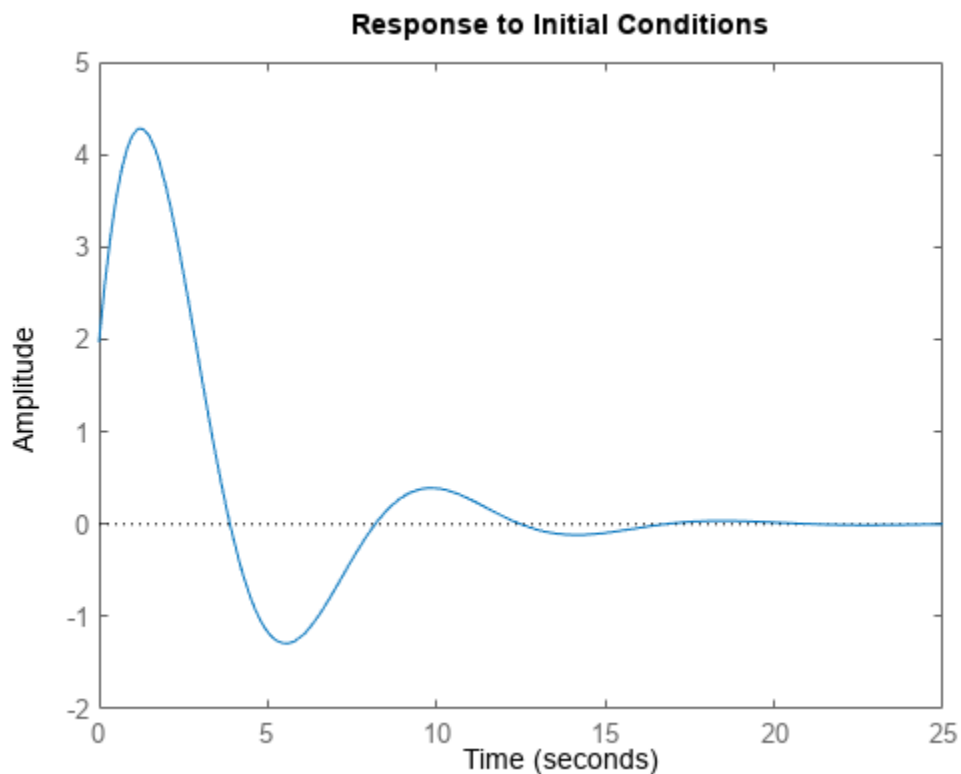

Initial Condition Response Plot of MIMO System

Consider the following two-input, two-output dynamic system.

$$\text{sys}(s) = \begin{bmatrix} 0 & \frac{3s}{s^2 + s + 10} \\ \frac{s+1}{s+5} & \frac{2}{s+6} \end{bmatrix}.$$

Convert the `sys` to state-space form since initial condition response plots are supported only for state-space models.

```
sys = ss([0, tf([3 0],[1 1 10]) ; tf([1 1],[1 5]), tf(2,[1 6])]);
size(sys)
```

State-space model with 2 outputs, 2 inputs, and 4 states.

The resultant state-space model has four states. Hence, provide an initial condition vector with four elements.

```
x0 = [0.3,0.25,1,4];
```

Create the initial condition response plot.

```
initial(sys,x0);
```

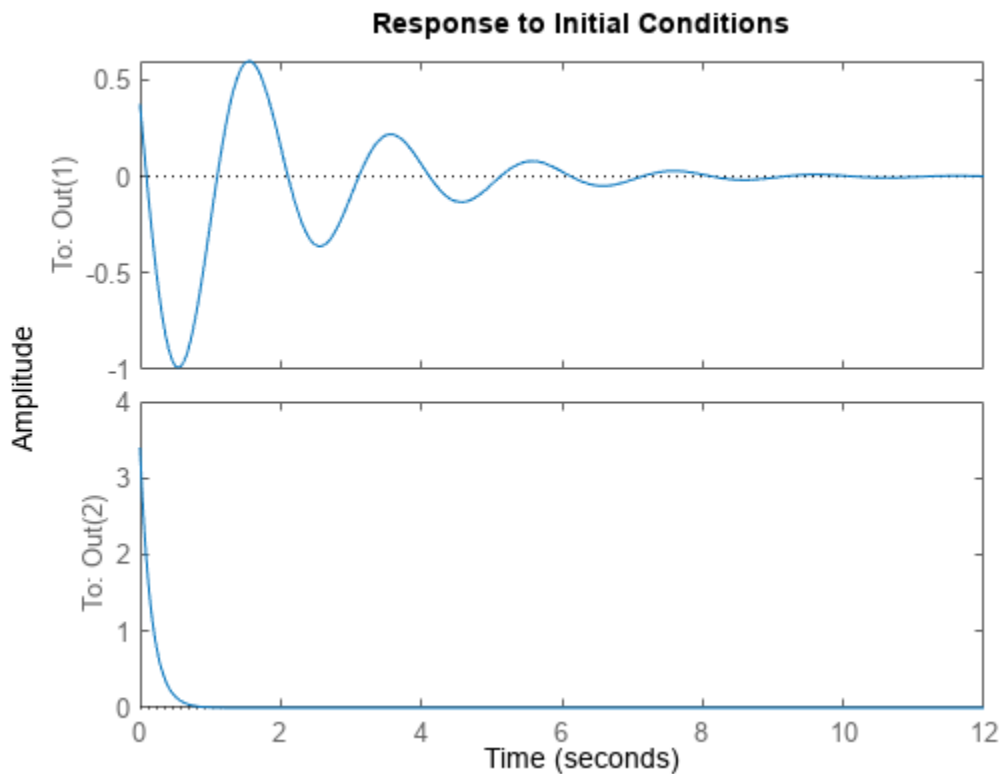

The resultant plot contains two subplots - one for each output in `sys`.

Initial Conditions Response Plot at Specified Time

For this example, examine the initial condition response of the following zero-pole-gain model and limit the plot to `tFinal = 15 s`.

First, convert the `zpk` model to an `ss` model since `initial` only supports state-space models.

```
sys = ss(zpk(-1,[-0.2+3j,-0.2-3j],1)*tf([1 1],[1 0.05]));
tFinal = 15;
x0 = [4,2,3];
```

Now, create the initial conditions response plot.

```
initial(sys,x0,tFinal);
```

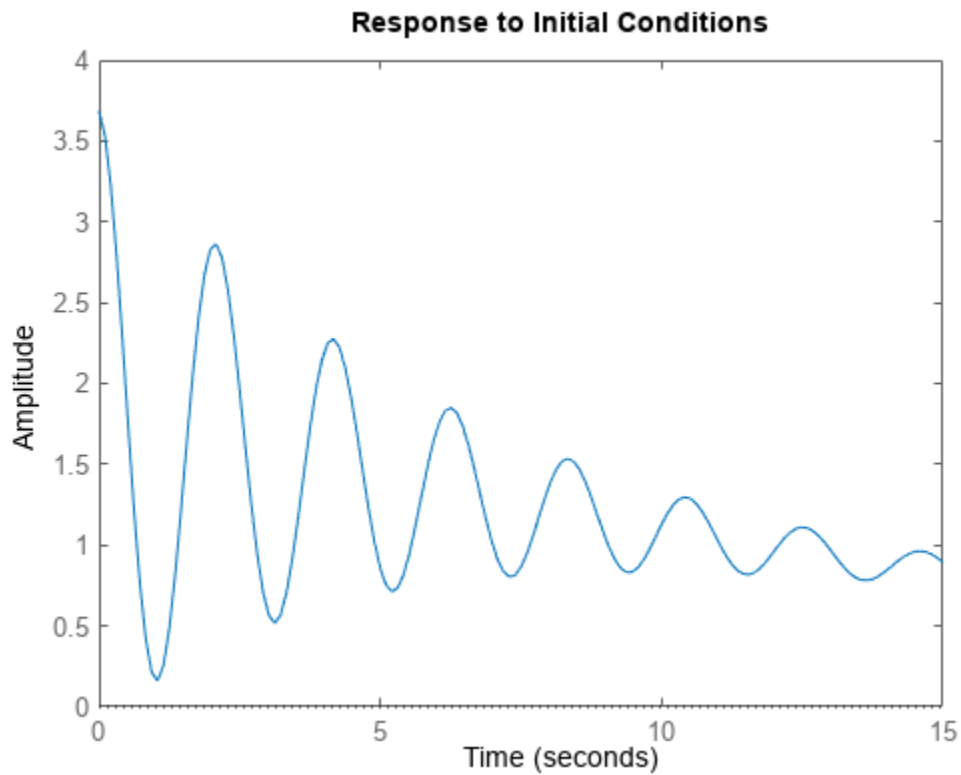

Initial Condition Responses of Multiple Systems

For this example, plot the initial condition responses of three dynamic systems.

First, create the three models and provide the initial conditions. All the models should have the same number of states.

```
rng('default');
sys1 = rss(4);
sys2 = rss(4);
sys3 = rss(4);
x0 = [1,1,1,1];
```

Plot the initial condition responses of the three models using time vector `t` that spans 5 seconds.

```
t = 0:0.1:5;
initial(sys1,'r--',sys2,'b',sys3,'g-.',x0,t)
```

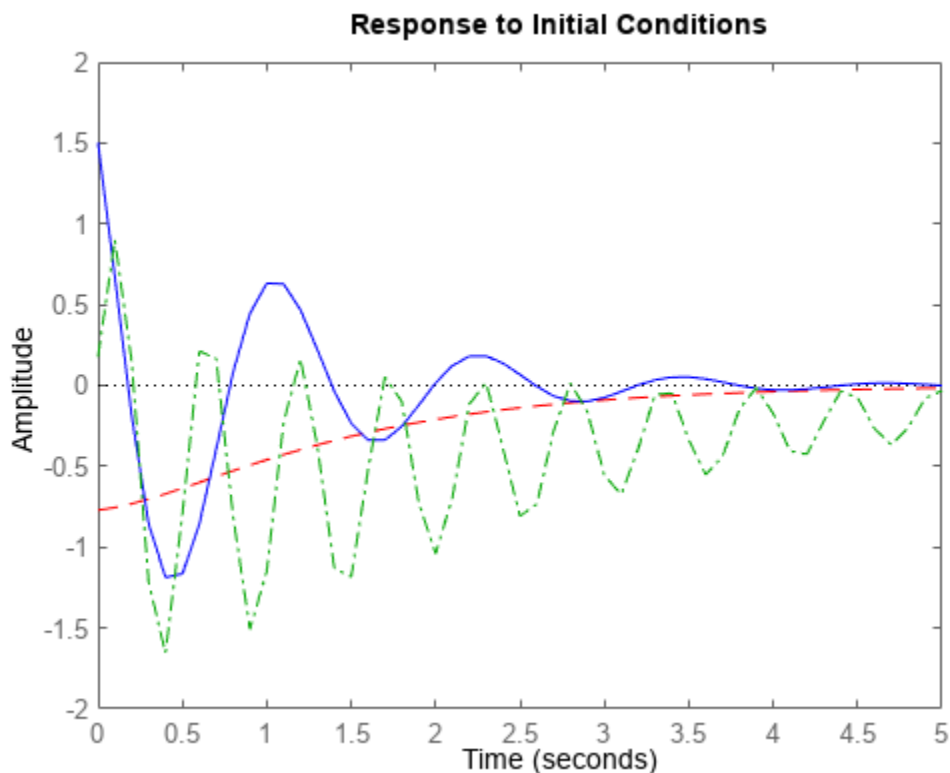
Initial Condition Response Data of State-Space Model

Extract the initial condition response data of the following state-space model with two states:

$$\begin{bmatrix} \dot{x}_1 \\ \dot{x}_2 \end{bmatrix} = \begin{bmatrix} -0.5572 & -0.7814 \\ 0.7814 & 0 \end{bmatrix} \begin{bmatrix} x_1 \\ x_2 \end{bmatrix}$$

$$y = [1.9691 \quad 6.4493] \begin{bmatrix} x_1 \\ x_2 \end{bmatrix}.$$

Use the following initial conditions:

$$x(0) = \begin{bmatrix} 1 \\ 0 \end{bmatrix}.$$

```
a = [-0.5572, -0.7814; 0.7814, 0];
c = [1.9691 6.4493];
x0 = [1 ; 0];
sys = ss(a,[],c,[]);
[y,tOut,x] = initial(sys,x0);
```

The array `y` has as many rows as time samples (length of `tOut`) and as many columns as outputs. Similarly, `x` has rows equal to the number of time samples (length of `tOut`) and as many columns as states.

Initial Condition Response Data with Specified Time

For this example, extract the initial condition response data of a state-space model with 6 states, 3 outputs and 2 inputs.

First, create the model and provide the initial conditions.

```
rng('default');  
sys = rss(6,3,2);  
x0 = [0.1,0.3,0.05,0.4,0.75,1];
```

Extract the initial condition responses of the model using time vector `t` that spans 15 seconds.

```
t = 0:0.1:15;  
[y,tOut,x] = initial(sys,x0,t);
```

The array `y` has as many rows as time samples (length of `tOut`) and as many columns as outputs. Similarly, `x` has rows equal to the number of time samples (length of `tOut`) and as many columns as states.

Input Arguments

sys — Dynamic system

dynamic system model | model array

Dynamic system, specified as a SISO or MIMO dynamic system model or array of dynamic system models. You can only use state-space models of the following types:

- Continuous-time or discrete-time numeric `ss` models.
- Generalized or uncertain LTI models such as `genss` or `uss` models. (Using uncertain models requires Robust Control Toolbox software.)
 - For tunable control design blocks, the function evaluates the model at its current value for both plotting and returning response data.
 - For uncertain control design blocks, the function plots the nominal value and random samples of the model. When you use output arguments, the function returns response data for the nominal model only.
- Sparse state-space models such as `sparss` and `mechss` models. You must specify final time `tFinal` for sparse state-space models.

If `sys` is an array of models, the function plots the responses of all models in the array on the same axes.

tFinal — End time to compute the response

positive scalar

End time to compute the response, specified as a positive scalar value. `initial` simulates the response from `t = 0` to `t = tFinal`.

- For continuous-time systems, the function determines the step size and number of points automatically from system dynamics. Express `tFinal` in the system time units, specified in the `TimeUnit` property of `sys`.
- For discrete-time systems, the function uses the sample time of `sys` as the step size. Express `tFinal` in the system time units, specified in the `TimeUnit` property of `sys`.
- For discrete-time systems with unspecified sample time ($T_s = -1$), `initial` interprets `tFinal` as the number of sampling periods to simulate.

t — Time vector

vector

Time vector at which to compute the response, specified as a vector of positive scalar values. Express `t` in the system time units, specified in the `TimeUnit` property of `sys`.

- For continuous-time models, specify `t` in the form `Ti:dt:Tf`. To obtain the response at each time step, the function uses `dt` as the sample time of a discrete approximation to the continuous system.
- For discrete-time models, specify `t` in the form `Ti:T_s:Tf`, where T_s is the sample time of `sys`.

`initial` always applies the input at $t = 0$, regardless of T_i .

LineStyle — Line style, marker, and color

character vector | string

Line style, marker, and color, specified as a string or vector of one, two, or three characters. The characters can appear in any order. You do not need to specify all three characteristics (line style, marker, and color). For example, if you omit the line style and specify the marker, then the plot shows only the marker and no line. For more information about configuring this argument, see the `LineStyle` input argument of the `plot` function.

Example: `'r--'` specifies a red dashed line

Example: `'*b'` specifies blue asterisk markers

Example: `'y'` specifies a yellow line

x0 — Initial condition of the states

vector

Initial condition of the states, specified as a vector. `x0` must have the same length as the number of states in `sys`.

Output Arguments

y — Response data

array

Response data, returned as an array.

- For SISO systems, `y` is a column vector of the same length as `t` (if provided) or `tOut` (if you do not provide `t`).
- For single-input, multi-output systems, `y` is a matrix with as many rows as there are time samples and as many columns as there are outputs. Thus, the j th column of `y`, or `y(:,j)`, contains the response of from the input to the j th output.

- For MIMO systems, the dimensions of y are then N -by- N_y , where:
 - N is the number of time samples.
 - N_y is the number of system outputs.

t0ut — Times at which response is computed

vector

Times at which response is computed, returned as a vector. When you do not provide a specific vector t of times, `initial` chooses this time vector based on the system dynamics. The times are expressed in the time units of `sys`.

x — State trajectories

array

State trajectories, returned as an array. x contains the evolution of the states of `sys` at each time in t or `t0ut`. The dimensions of x are N -by- N_x , where:

- N is the number of time samples.
- N_x is the number of states.

Version History

Introduced before R2006a**See Also**`initialplot` | `impulse` | `lsim` | **Linear System Analyzer** | `step`**Topics**

“Ways to Customize Plots”

“Response from Initial Conditions”

initialize

Initialize the state of the particle filter

Syntax

```
initialize(pf,numParticles,mean,covariance)
initialize(pf,numParticles,stateBounds)
initialize( ___,Name,Value)
```

Description

`initialize(pf,numParticles,mean,covariance)` initializes a particle filter object with a specified number of particles. The initial states of the particles in the state space are determined by sampling from the multivariate normal distribution with the specified mean and covariance. The number of state variables (`NumStateVariables`) is retrieved automatically based on the length of the mean vector.

`initialize(pf,numParticles,stateBounds)` determines the initial location of `numParticles` particles by sampling from the multivariate uniform distribution with the given `stateBounds`.

`initialize(___,Name,Value)` initializes the particles with additional options specified by one or more `Name,Value` pair arguments.

Examples

Initialize Particle Filter Object for Online State Estimation

To create a particle filter object for estimating the states of your system, create appropriate state transition function and measurement function for the system.

In this example, the functions `vdpParticleFilterStateFcn` and `vdpMeasurementLikelihoodFcn` describe a discrete-approximation to van der Pol oscillator with nonlinearity parameter, `mu`, equal to 1.

Create the particle filter object. Use function handles to provide the state transition and measurement likelihood functions to the object.

```
myPF = particleFilter(@vdpParticleFilterStateFcn,@vdpMeasurementLikelihoodFcn);
```

Initialize the particle filter at state `[2; 0]` with unit covariance, and use 1000 particles.

```
initialize(myPF, 1000, [2;0], eye(2));
myPF
```

```
myPF =
  particleFilter with properties:
```

```
    NumStateVariables: 2
      NumParticles: 1000
  StateTransitionFcn: @vdpParticleFilterStateFcn
```

```
MeasurementLikelihoodFcn: @vdpMeasurementLikelihoodFcn
IsStateVariableCircular: [0 0]
  ResamplingPolicy: [1x1 particleResamplingPolicy]
  ResamplingMethod: 'multinomial'
StateEstimationMethod: 'mean'
StateOrientation: 'column'
  Particles: [2x1000 double]
  Weights: [1.0000e-03 1.0000e-03 1.0000e-03 ... ]
  State: 'Use the getStateEstimate function to see the value.'
StateCovariance: 'Use the getStateEstimate function to see the value.'
```

To estimate the states and state estimation error covariance from the constructed object, use the `predict` and `correct` commands.

Input Arguments

pf — Particle filter

`particleFilter` object

Particle filter, specified as a object. See `particleFilter` for more information.

numParticles — Number of particles used in the filter

scalar

Number of particles used in the filter, specified as a scalar.

Unless performance is an issue, do not use fewer than 1000 particles. A higher number of particles can improve the estimate but sacrifices performance speed, because the algorithm has to process more particles. Tuning the number of particles is the best way to improve the tracking of your particle filter.

mean — Mean of particle distribution

vector

Mean of particle distribution, specified as a vector. The `NumStateVariables` property of `pf` is set based on the length of this vector.

covariance — Covariance of particle distribution

N-by-*N* matrix

Covariance of particle distribution, specified as an *N*-by-*N* matrix, where *N* is the value of `NumStateVariables` property from `pf`.

stateBounds — Bounds of state variables

n-by-2 matrix

Bounds of state variables, specified as an *n*-by-2 matrix. The `NumStateVariables` property of `pf` is set based on the value of *n*. Each row corresponds to the lower and upper limit of the corresponding state variable. The number of state variables (`NumStateVariables`) is retrieved automatically based on the number of rows of the `stateBounds` array.

Name-Value Pair Arguments

Specify optional pairs of arguments as `Name1=Value1, ..., NameN=ValueN`, where `Name` is the argument name and `Value` is the corresponding value. Name-value arguments must appear after other arguments, but the order of the pairs does not matter.

Before R2021a, use commas to separate each name and value, and enclose `Name` in quotes.

Example: `... 'StateOrientation', 'row'`

CircularVariables – Circular variables

logical vector

Circular variables, the comma-separated pair consisting of `CircularVariables` and specified as a logical vector. Each state variable that uses circular or angular coordinates is indicated with a 1. The length of the vector is equal to the `NumStateVariables` property of `particleFilter`.

StateOrientation – Orientation of states

'column' (default) | 'row'

Orientation of states, specified as the comma-separated pair consisting of `StateOrientation` as one of these values: 'column' or 'row'. If it is 'column', `State` property and `getStateEstimate` method of the object `pf` returns the states as a column vector, and the `Particles` property has dimensions `NumStateVariables-by-NumParticles`. If it is 'row', the states have the row orientation and `Particles` has dimensions `NumParticles-by-NumStateVariables`.

Version History

Introduced in R2017b

See Also

`predict` | `correct` | `particleFilter` | `unscentedKalmanFilter` | `extendedKalmanFilter` | `clone`

Topics

“Nonlinear State Estimation Using Unscented Kalman Filter and Particle Filter”

“Generate Code for Online State Estimation in MATLAB”

initialplot

Plot initial condition response with additional plot customization options

Syntax

```
h = initialplot(sys,x0)
h = initialplot(sys1,sys2,...,sysN,x0)
h = initialplot(sys1,LineStyle1,...,sysN,LineStyleN,x0)
h = initialplot( __ ,tFinal)
h = initialplot( __ ,t)
h = initialplot(AX, __ )
h = initialplot( __ ,plotoptions)
```

Description

`initialplot` lets you plot initial condition responses with a broader range of plot customization options than `initial`. You can use `initialplot` to obtain the plot handle and use it to customize the plot, such as modify the axes labels, limits and units. You can also use `initialplot` to plot initial condition response on an existing set of axes represented by an axes handle. To customize an existing plot using the plot handle:

- 1 Obtain the plot handle
- 2 Use `getoptions` to obtain the option set
- 3 Update the plot using `setoptions` to modify the required options

For more information, see “Customizing Response Plots from the Command Line”. To create initial condition response plots with default options or to extract initial condition response data, use `initial`.

`h = initialplot(sys,x0)` plots the initial condition response of states of the dynamic system model `sys` and returns the plot handle `h` to the plot. You can use this handle `h` to customize the plot with the `getoptions` and `setoptions` commands.

`h = initialplot(sys1,sys2,...,sysN,x0)` plots the initial condition response of multiple dynamic systems `sys1,sys2,...,sysN` on the same plot. All systems must have the same number of inputs and outputs to use this syntax.

`h = initialplot(sys1,LineStyle1,...,sysN,LineStyleN,x0)` sets the line style, marker type, and color for the initial condition response of each system. All systems must have the same number of inputs and outputs to use this syntax.

`h = initialplot(__ ,tFinal)` simulates the response of initial conditions from $t = 0$ to the final time $t = tFinal$. Specify `tFinal` in the system time units, specified in the `TimeUnit` property of `sys`. For discrete-time systems with unspecified sample time ($T_s = -1$), `initialplot` interprets `tFinal` as the number of sampling intervals to simulate.

`h = initialplot(__ ,t)` simulates the response of initial conditions using the time vector `t`. Specify `t` in the system time units, specified in the `TimeUnit` property of `sys`.

`h = initialplot(AX, ___)` plots the initial condition response of the states on the Axes object in the current figure with the handle AX.

`h = initialplot(___, plotoptions)` plots the response of the initial conditions with the options set specified in `plotoptions`. You can use these options to customize the plot appearance using the command line. Settings you specify in `plotoptions` overrides the preference settings in the MATLAB session in which you run `initialplot`. Therefore, this syntax is useful when you want to write a script to generate multiple plots that look the same regardless of the local preferences.

Examples

Customize Initial Conditions Plot using Plot Handle

For this example, use the plot handle to change the time units to minutes and turn on the grid.

Generate a random state-space model with 5 states and create the initial condition response plot with plot handle h.

```
rng("default")
sys = rss(5);
x0 = [1,2,3,4,5];
h = initialplot(sys,x0);
```

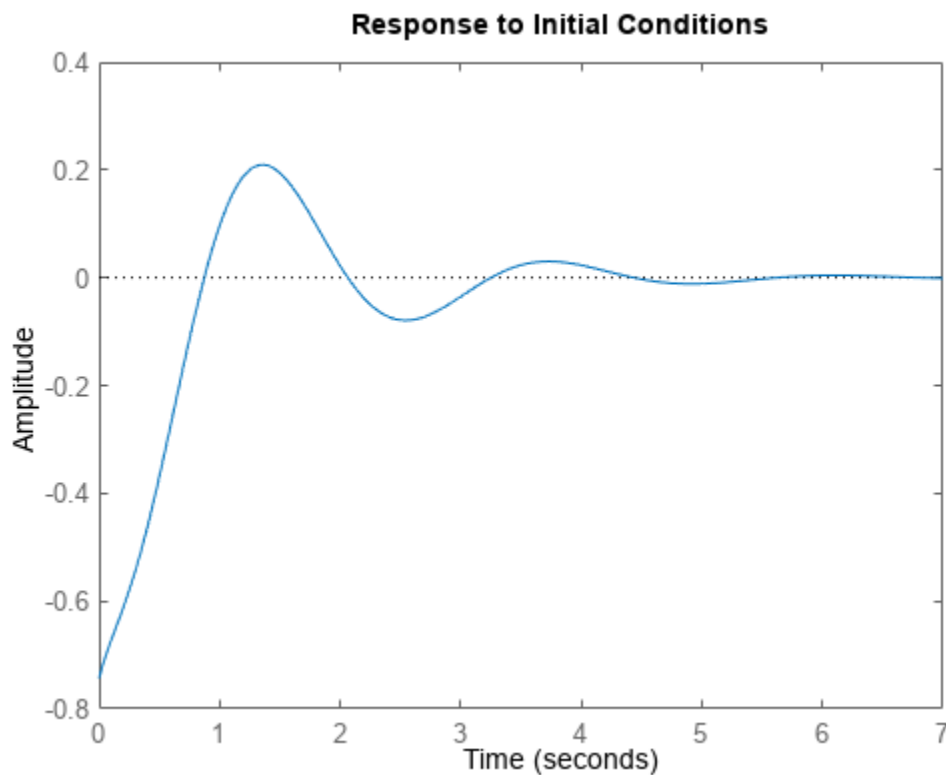

Change the time units to minutes and turn on the grid. To do so, edit properties of the plot handle, h using `setoptions`.

```
setoptions(h,'TimeUnits','minutes','Grid','on');
```

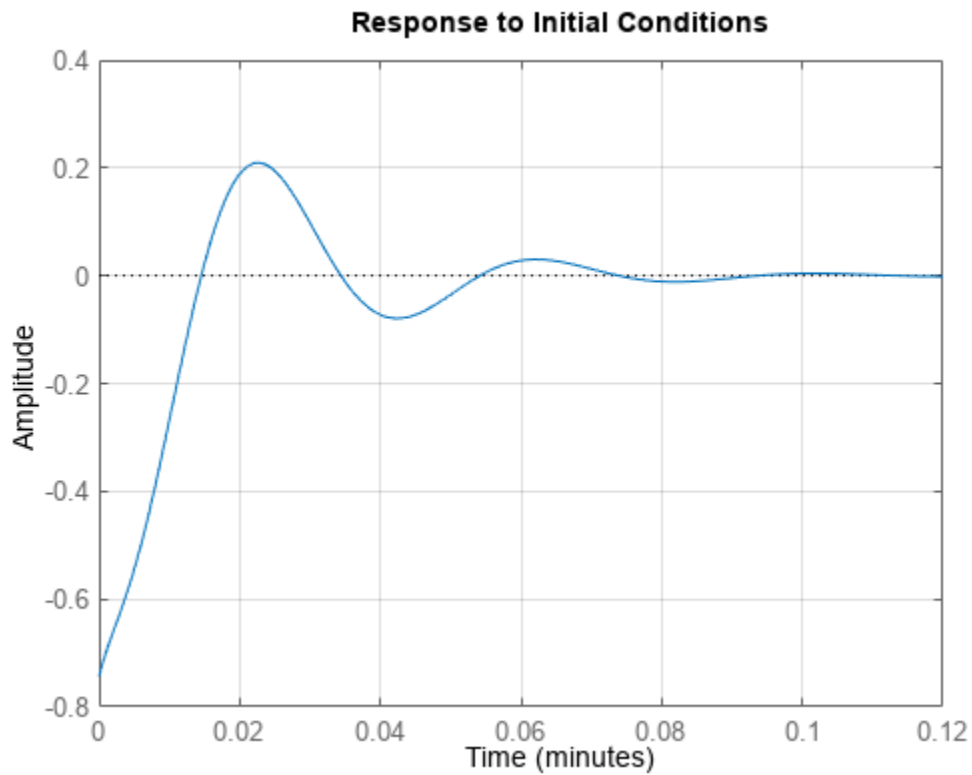

The plot automatically updates when you call `setoptions`.

Alternatively, you can also use the `timeoptions` command to specify the required plot options. First, create an options set based on the toolbox preferences.

```
plotoptions = timeoptions('cstprefs');
```

Change properties of the options set by setting the time units to minutes and enabling the grid.

```
plotoptions.TimeUnits = 'minutes';  
plotoptions.Grid = 'on';  
h = initialplot(sys,x0,plotoptions);
```

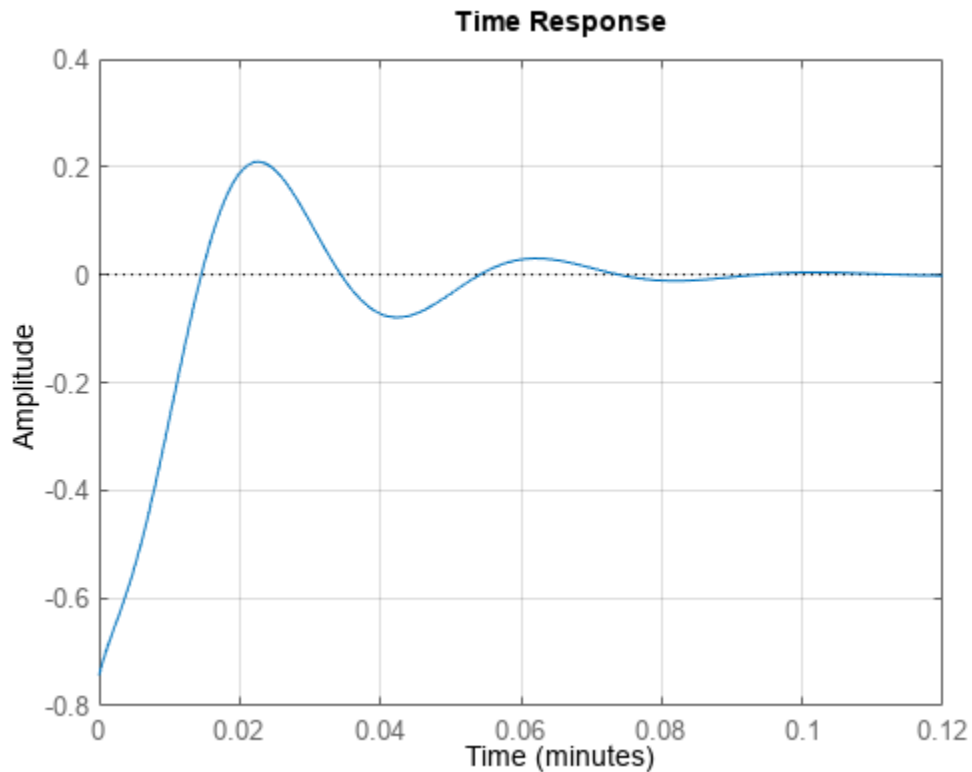

You can use the same option set to create multiple initial condition plots with the same customization. Depending on your own toolbox preferences, the plot you obtain might look different from this plot. Only the properties that you set explicitly, in this example `TimeUnits` and `Grid`, override the toolbox preferences.

Custom Initial Condition Plot of MIMO System

Consider the following two-input, two-output dynamic system.

$$\text{sys}(s) = \begin{bmatrix} 0 & \frac{3s}{s^2 + s + 10} \\ \frac{s+1}{s+5} & \frac{2}{s+6} \end{bmatrix}.$$

Convert the `sys` to state-space form since initial condition plots are supported only for state-space models.

```
sys = ss([0, tf([3 0],[1 1 10]) ; tf([1 1],[1 5]), tf(2,[1 6])]);
size(sys)
```

State-space model with 2 outputs, 2 inputs, and 4 states.

The resultant state-space model has four states. Hence, provide an initial condition vector with four elements.

```
x0 = [0.3,0.25,1,4];
```

Use `timeoptions` to create a plot options set and turn the grid on. Provide an appropriate title before creating the initial conditions plot.

```
plotoptions = timeoptions;
plotoptions.Grid = 'on';
plotoptions.Title.String = 'Initial Condition Plot of MIMO System sys(s)';
h = initialplot(sys,x0,plotoptions);
```

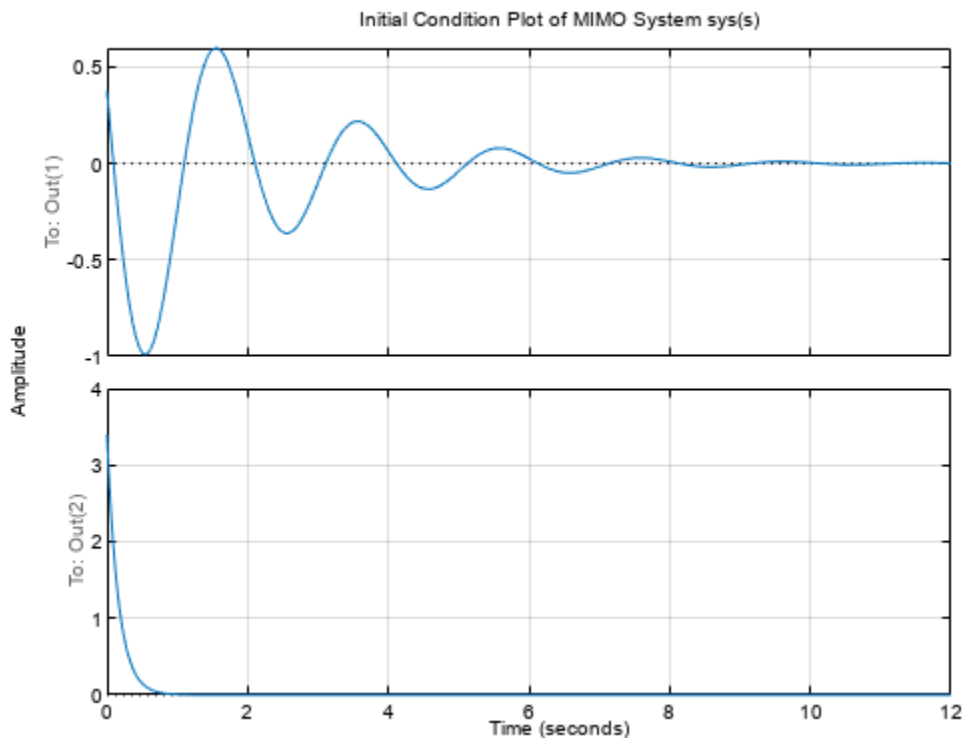

Initial Condition Plot with Specified Grid Color

For this example, consider a MIMO state-space model with 3 inputs, 3 outputs and 3 states. Create an initial condition plot with red colored grid lines.

Create the MIMO state-space model `sys_mimo`.

```
J = [8 -3 -3; -3 8 -3; -3 -3 8];
F = 0.2*eye(3);
A = -J\F;
B = inv(J);
C = eye(3);
D = 0;
sys_mimo = ss(A,B,C,D);
size(sys_mimo)
```

State-space model with 3 outputs, 3 inputs, and 3 states.

Create an initial condition plot with plot handle `h` and use `getoptions` for a list of the options available.

```
x0 = [0.35,0.1,4];
h = initialplot(sys_mimo,x0);
```

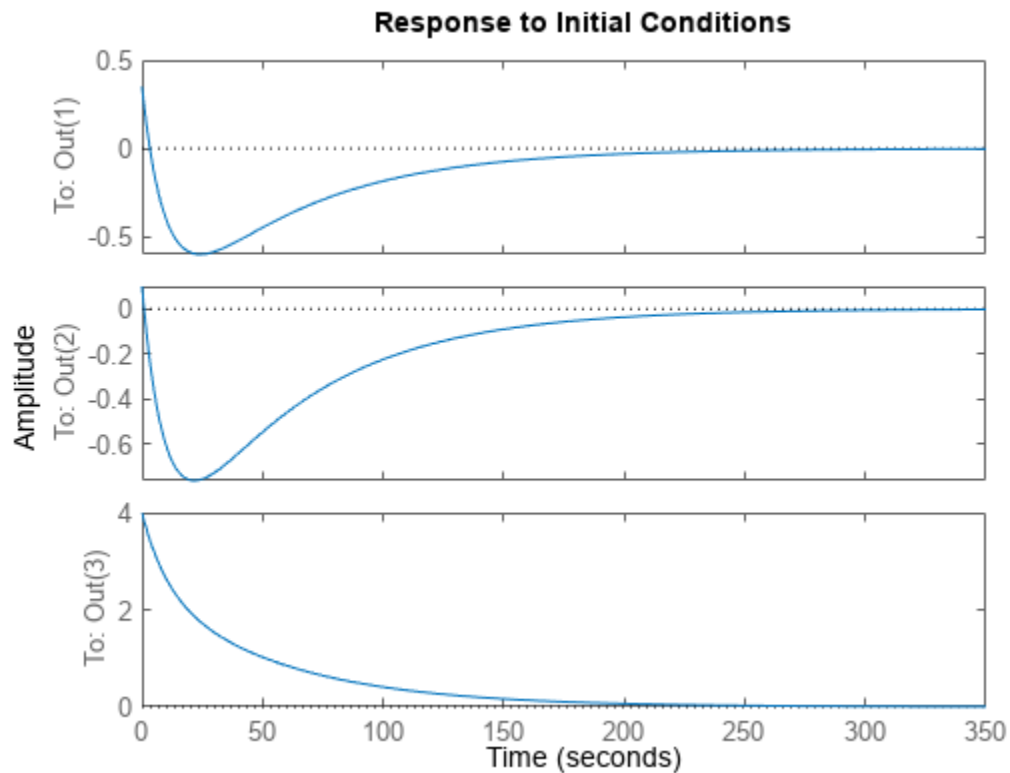

```
p = getoptions(h)
```

```
p =
```

```

        Normalize: 'off'
    SettleTimeThreshold: 0.0200
        RiseTimeLimits: [0.1000 0.9000]
            TimeUnits: 'seconds'
ConfidenceRegionNumberSD: 1
        IOGrouping: 'none'
        InputLabels: [1x1 struct]
        OutputLabels: [1x1 struct]
        InputVisible: {0x1 cell}
        OutputVisible: {3x1 cell}
            Title: [1x1 struct]
            XLabel: [1x1 struct]
            YLabel: [1x1 struct]
        TickLabel: [1x1 struct]
            Grid: 'off'
        GridColor: [0.1500 0.1500 0.1500]
```

```

XLim: {[0 350]}
YLim: {3x1 cell}
XLimMode: {'auto'}
YLimMode: {3x1 cell}

```

Use `setoptions` to update the plot with the requires customization.

```
setoptions(h, 'Grid', 'on', 'GridColor', [1 0 0]);
```

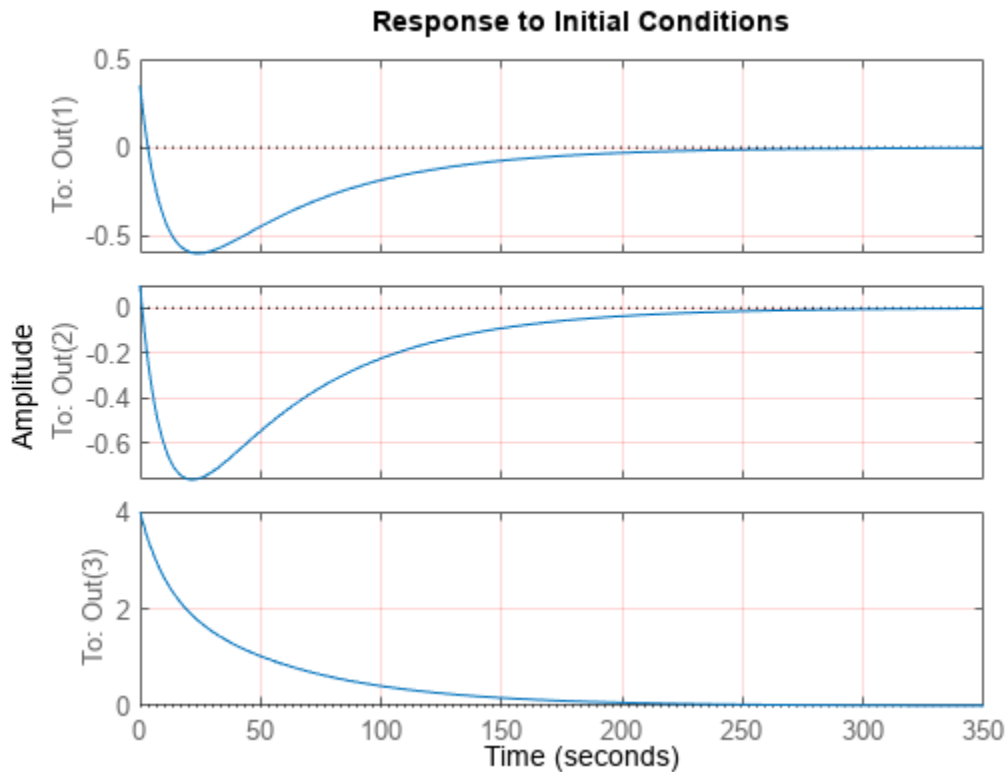

The plot automatically updates when you call `setoptions`. For MIMO models, `initialplot` produces a grid of plots, each plot displaying the initial condition response of one I/O pair.

Customized Initial Conditions Response Plot at Specified Time

For this example, examine the initial condition response of the following zero-pole-gain model and limit the plot to `tFinal = 15` s. Use 15-point blue text for the title. This plot should look the same, regardless of the preferences of the MATLAB session in which it is generated.

First, convert the zpk model to an ss model since `initialplot` only supports state-space models.

```

sys = ss(zpk(-1,[-0.2+3j,-0.2-3j],1)*tf([1 1],[1 0.05]));
tFinal = 15;
x0 = [4,2,3];

```

Then, create a default options set using `timeoptions`.

```
plotoptions = timeoptions;
```

Next change the required properties of the options set `plotoptions`.

```
plotoptions.Title.FontSize = 15;
plotoptions.Title.Color = [0 0 1];
```

Now, create the initial conditions response plot using the options set `plotoptions`.

```
h = initialplot(sys,x0,tFinal,plotoptions);
```

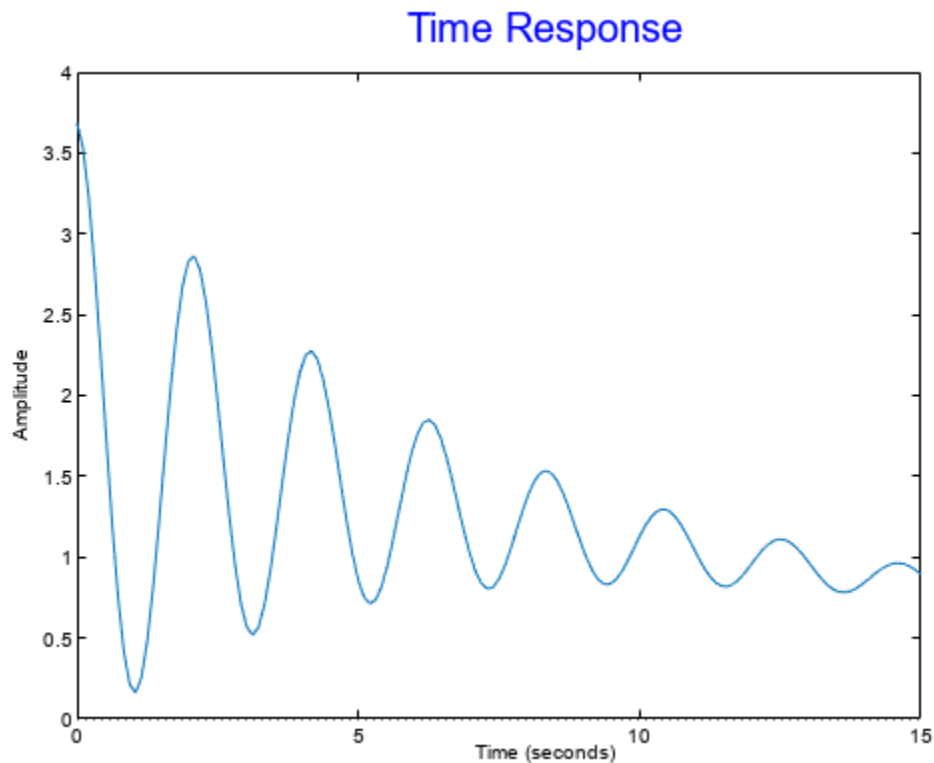

Because `plotoptions` begins with a fixed set of options, the plot result is independent of the toolbox preferences of the MATLAB session.

Plot Initial Condition Responses of Multiple Systems

For this example, plot the initial condition responses of three dynamic systems and use the plot handle to enable the grid.

First, create the three models and provide the initial conditions.

```
rng('default');
sys1 = rss(4);
sys2 = rss(4);
```

```
sys3 = rss(4);  
x0 = [1,1,1,1];
```

Plot the initial condition responses of the three models.

```
t = 0:0.1:5;  
h = initialplot(sys1, 'r--', sys2, 'b', sys3, 'g-.', x0, t);  
legend('sys1', 'sys2', 'sys3')
```

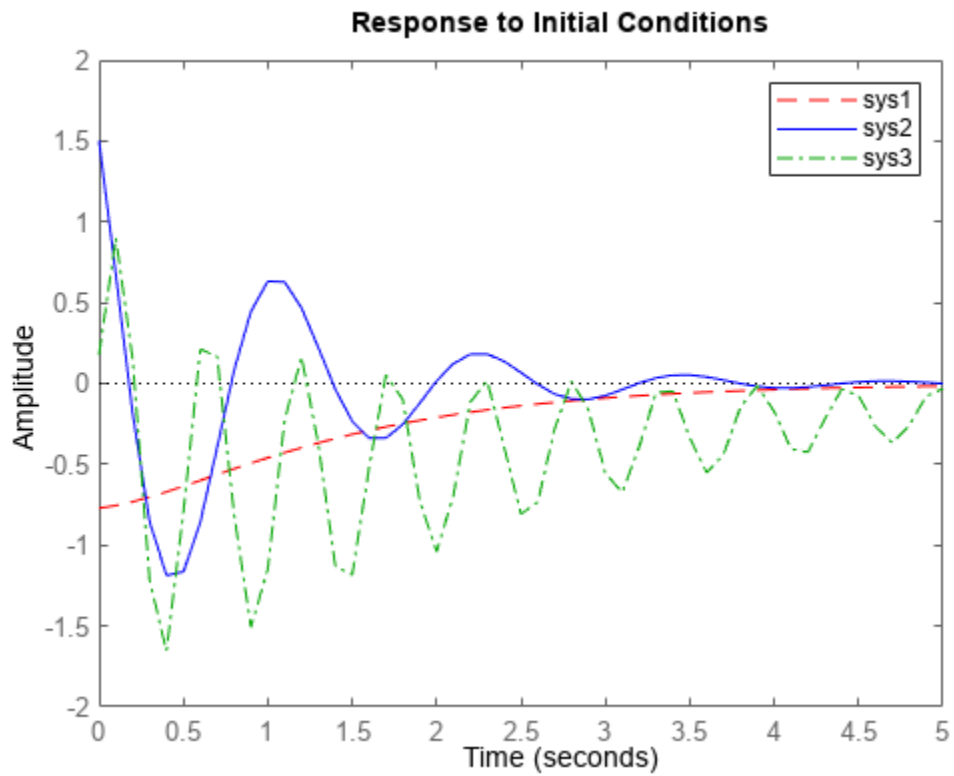

Use the plot handle to enable the grid.

```
setoptions(h, 'Grid', 'on');
```

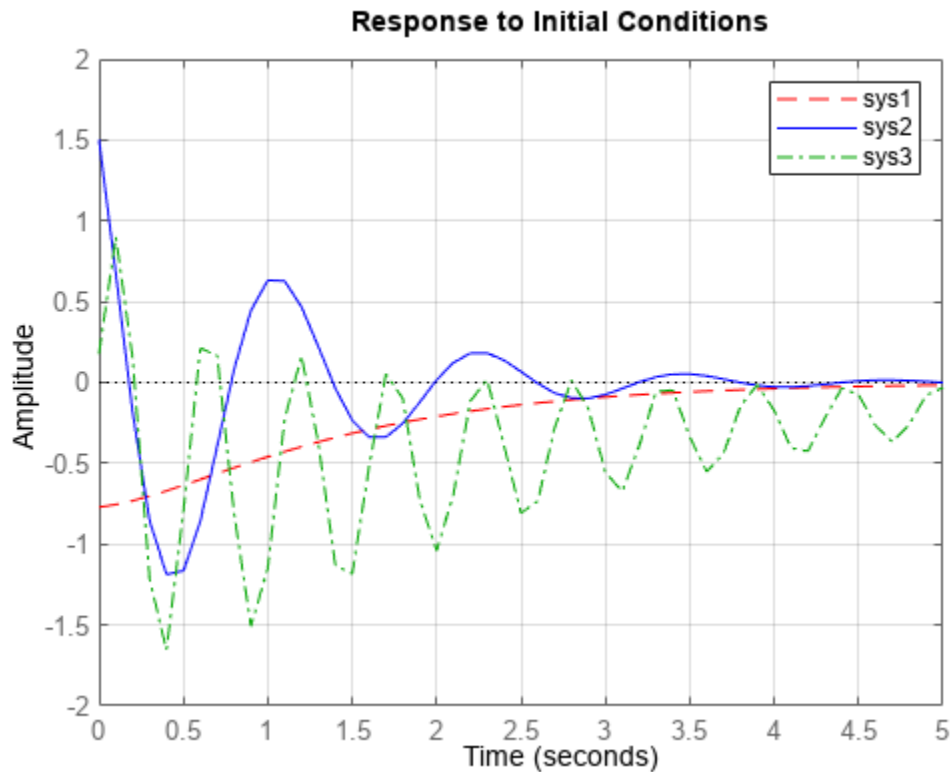
Input Arguments

sys — Dynamic system

dynamic system model | model array

Dynamic system, specified as a SISO or MIMO dynamic system model or array of dynamic system models. Dynamic systems that you can use include:

- State-space `ss` models.
- Sparse state-space models, such as `sparss` or `mechss` models. Final time `tFinal` must be specified when using sparse models.
- Generalized or uncertain state-space models such as `genss` or `uss` models. (Using uncertain models requires Robust Control Toolbox software.)
 - For tunable control design blocks, the function evaluates the model at its current value to plot the step response data.
 - For uncertain control design blocks, the function plots the nominal value and random samples of the model.
- Identified state-space models, such as `idss` models. (Using identified models requires System Identification Toolbox software.)

If `sys` is an array of models, the function plots the initial condition response of all models in the array on the same axes.

x0 — Initial condition of states

vector

Initial condition of states, specified as a vector of size equal to the number of states in `sys`.

LineStyle — Line style, marker, and color

character vector | string

Line style, marker, and color, specified as a character vector or string containing symbols. The symbols can appear in any order. You do not need to specify all three characteristics (line style, marker, and color). For example, if you omit the line style and specify the marker, then the plot shows only the marker and no line.

Example: `'--or'` is a red dashed line with circle markers

Line Style	Description
-	Solid line
--	Dashed line
:	Dotted line
-. .	Dash-dot line

Marker	Description
'o'	Circle
'+'	Plus sign
'*'	Asterisk
'.'	Point
'x'	Cross
'_'	Horizontal line
' '	Vertical line
's'	Square
'd'	Diamond
'^'	Upward-pointing triangle
'v'	Downward-pointing triangle
'>'	Right-pointing triangle
'<'	Left-pointing triangle
'p'	Pentagram
'h'	Hexagram

Color	Description
y	yellow
m	magenta
c	cyan
r	red

Color	Description
g	green
b	blue
w	white
k	black

tFinal — Final time for initial condition response computation

scalar

Final time for initial condition response computation, specified as a scalar. Specify `tFinal` in the system time units, specified in the `TimeUnit` property of `sys`. For discrete-time systems with unspecified sample time ($T_s = -1$), `initialplot` interprets `tFinal` as the number of sampling intervals to simulate.

t — Time for initial condition response simulation

vector

Time for initial condition response simulation, specified as a vector. Specify the time vector `t` in the system time units, specified in the `TimeUnit` property of `sys`. The time vector must be real, finite, and must contain monotonically increasing and evenly spaced time samples.

The time vector `t` is:

- $t = T_{initial}:T_{sample}:T_{final}$, for discrete-time systems.
- $t = T_{initial}:dt:T_{final}$, for continuous-time systems. Here, dt is the sample time of a discrete approximation of the continuous-time system.

AX — Target axes

Axes object

Target axes, specified as an Axes object. If you do not specify the axes and if the current axes are Cartesian axes, then `initialplot` plots on the current axes. Use `AX` to plot into specific axes when creating a plot of the initial condition response.

plotoptions — Initial condition plot options set

TimePlotOptions object

Initial condition plot options set, specified as a `TimePlotOptions` object. You can use this option set to customize the plot appearance. Use `timeoptions` to create the option set. Settings you specify in `plotoptions` overrides the preference settings in the MATLAB session in which you run `impzplot`. Therefore, `plotoptions` is useful when you want to write a script to generate multiple plots that look the same regardless of the local preferences.

For the list of available options, see `timeoptions`.

Output Arguments

h — Plot handle

handle object

Plot handle, returned as a `handle` object. Use the handle `h` to get and set the properties of the plot using `getoptions` and `setoptions`. For the list of available options, see the *Properties and Values Reference* section in “Customizing Response Plots from the Command Line”.

Version History

Introduced before R2006a

See Also

`getoptions` | `initial` | `setoptions`

Topics

“Customizing Response Plots from the Command Line”

interface

Specify physical connections between components of mechss model

Syntax

```
sysCon = interface(sys,C1,IC1,C2,IC2)
```

```
sysCon = interface(sys,C,IC)
```

```
sysCon = interface( ____,KI,CI)
```

```
sysCon = interface( ____,method)
```

Description

`sysCon = interface(sys,C1,IC1,C2,IC2)` specifies physical couplings between components C1 and C2 in the second-order sparse model `sys`. IC1 and IC2 contain the indices of the coupled degrees of freedom (DOFs) relative to the DOFs of C1 and C2. The physical interface is assumed rigid and satisfies the standard consistency and equilibrium conditions. `sysCon` is the resultant model with the specified physical connections. Use `showStateInfo` to get the list of all available components of `sys`.

`sysCon = interface(sys,C,IC)` specifies that component C interfaces with the ground. Connecting the degrees of freedom `q` of C to the ground amounts to the zero displacement constraint $q(IC) = 0$.

`sysCon = interface(____,KI,CI)` further specifies the stiffness KI and damping CI for nonrigid interfaces.

`sysCon = interface(____,method)` specifies the assembly method. By default, `method = 'dual'` and the function uses the dual-assembly method of physical coupling. Set `method = 'primal'` to use the primal-assembly method of physical coupling. For more information, see "Algorithms" on page 2-560.

Examples

Physical Connections Between Components in Sparse Second-Order Model

For this example, consider a structural model that consists of two square plates connected with pillars at each vertex as depicted in the figure below. The lower plate is attached rigidly to the ground while the pillars are attached rigidly to each vertex of the square plate.

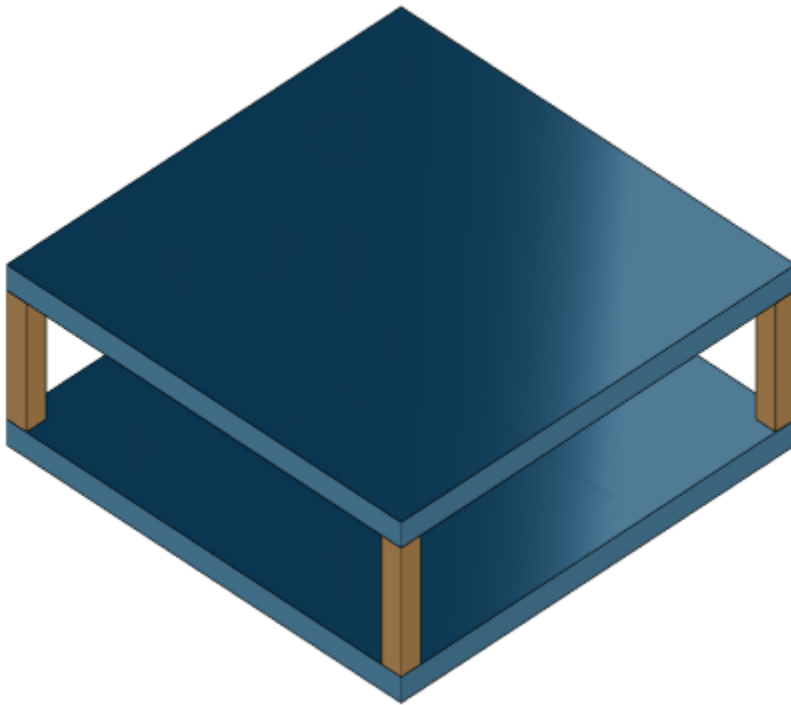

Load the finite element model matrices contained in `platePillarModel.mat` and create the sparse second-order model representing the above system.

```
load('platePillarModel.mat')
model = ...
    mechss(M1,[],K1,B1,F1,'Name','Plate1') + ...
    mechss(M2,[],K2,B2,F2,'Name','Plate2') + ...
    mechss(Mp,[],Kp,Bp,Fp,'Name','Pillar3') + ...
    mechss(Mp,[],Kp,Bp,Fp,'Name','Pillar4') + ...
    mechss(Mp,[],Kp,Bp,Fp,'Name','Pillar5') + ...
    mechss(Mp,[],Kp,Bp,Fp,'Name','Pillar6');
sys = model;
```

Use `showStateInfo` to examine the components of the `mechss` model object.

```
showStateInfo(sys)
```

The state groups are:

Type	Name	Size
Component	Plate1	2646
Component	Plate2	2646
Component	Pillar3	132
Component	Pillar4	132
Component	Pillar5	132
Component	Pillar6	132

Now, load the interfaced degree of freedom (DOF) index data from `dofData.mat` and use `interface` to create the physical connections between the two plates and the four pillars. `dofs` is a 6x7 cell array where the first two rows contain DOF index data for the first and second plates while the remaining four rows contain index data for the four pillars. By default, the function uses dual-assembly method of physical coupling.

```
load('dofData.mat','dofs')
for i=3:6
    sys = interface(sys,"Plate1",dofs{1,i},"Pillar"+i,dofs{i,1});
    sys = interface(sys,"Plate2",dofs{2,i},"Pillar"+i,dofs{i,2});
end
```

Specify connection between the bottom plate and the ground.

```
sysConDual = interface(sys,"Plate2",dofs{2,7});
```

Use `showStateInfo` to confirm the physical interfaces.

```
showStateInfo(sysConDual)
```

The state groups are:

Type	Name	Size
-----	-----	-----
Component	Plate1	2646
Component	Plate2	2646
Component	Pillar3	132
Component	Pillar4	132
Component	Pillar5	132
Component	Pillar6	132
Interface	Plate1-Pillar3	12
Interface	Plate2-Pillar3	12
Interface	Plate1-Pillar4	12
Interface	Plate2-Pillar4	12
Interface	Plate1-Pillar5	12
Interface	Plate2-Pillar5	12
Interface	Plate1-Pillar6	12
Interface	Plate2-Pillar6	12
Interface	Plate2-Ground	6

You can use `spy` to visualize the sparse matrices in the final model.

```
spy(sysConDual)
```

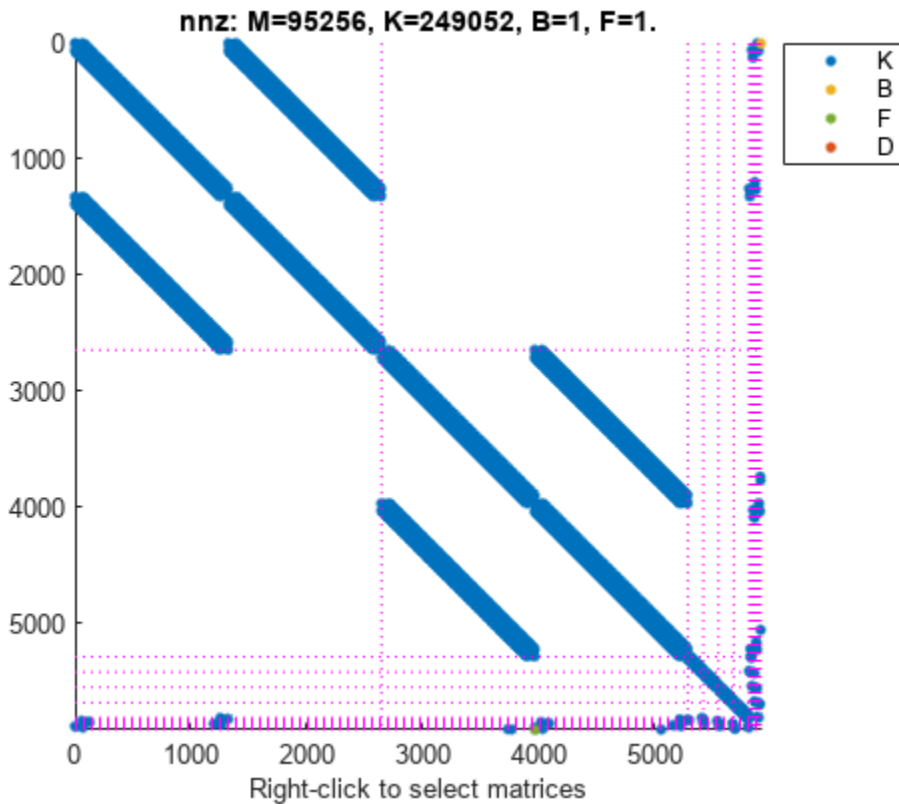

Now, specify physical connections using the primal-assembly method.

```
sys = model;
for i=3:6
    sys = interface(sys, "Plate1",dofs{1,i}, "Pillar"+i,dofs{i,1}, 'primal');
    sys = interface(sys, "Plate2",dofs{2,i}, "Pillar"+i,dofs{i,2}, 'primal');
end
sysConPrimal = interface(sys, "Plate2",dofs{2,7}, 'primal');
```

Use `showStateInfo` to confirm the physical interfaces.

```
showStateInfo(sysConPrimal)
```

The state groups are:

Type	Name	Size
Component	Plate1	2646
Component	Plate2	2640
Component	Pillar3	108
Component	Pillar4	108
Component	Pillar5	108
Component	Pillar6	108

Primal assembly eliminates half of the redundant DOFs associated with the shared set of DOFs in the global finite element mesh.

You can use `spy` to visualize the sparse matrices in the final model.

```
spy(sysConPrimal)
```

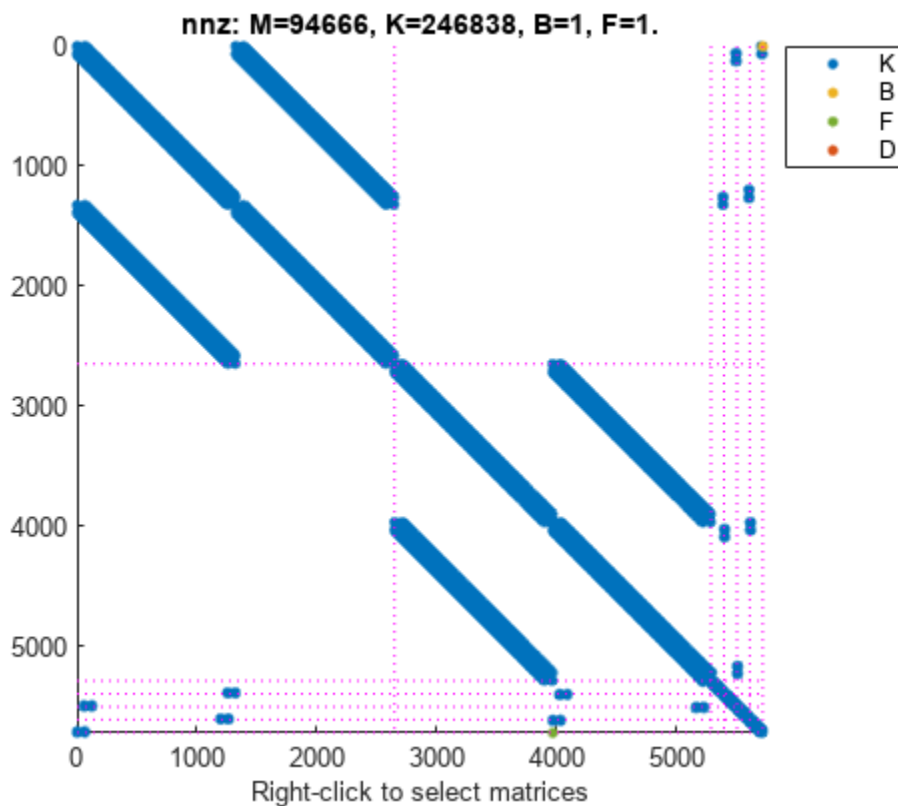

The data set for this example was provided by Victor Dolk from ASML.

Input Arguments

sys — Sparse second-order model

mechss model object

Sparse second-order model, specified as a mechss model object. For more information, see mechss.

C — Components to connect

string | array of character vectors

Components of sys to connect, specified as a string or an array of character vectors. Use showStateInfo to get the list of all available components of sys.

IC — Index information of components to connect

Nc-by-Ni cell array

Index information of components to connect, specified as an Nc-by-Ni cell array, where Nc is the number of components and Ni is the number of physical interfaces.

KI — Stiffness matrix

Nq-by-Nq sparse matrix

Stiffness matrix, specified as an N_q -by- N_q sparse matrix, where N_q is the number of DOFs in `sys`.

CI — Damping matrix

N_q -by- N_q sparse matrix

Damping matrix, specified as an N_q -by- N_q sparse matrix, where N_q is the number of DOFs in `sys`.

method — Assembly method

'dual' (default) | 'primal'

Interface assembly method, specified as one of the following:

- 'dual' — Use the dual-assembly method of physical coupling. This method maintains sparsity at the expense of additional algebraic variables.
- 'primal' — Use the primal-assembly method of physical coupling. This method uses a minimal number of DOFs but the system may suffer from fill-in.

For more information, see “Algorithms” on page 2-560.

Output Arguments

sysCon — Output system with physical interfaces

`mechss` model object

Output system with physical interfaces, returned as a `mechss` model object. Use `showStateInfo` to examine the list of physical interfaces in the system.

Algorithms

Dual-Assembly Model

Rigid interface

By default, `interface` uses the concept of *dual assembly* to physically connect the degrees of freedom (DOFs) of the model components. For n substructures in the physical domain, the sparse matrices in block diagonal form are:

$$M \triangleq \text{diag}(M_1, \dots, M_n) = \begin{bmatrix} M_1 & 0 & 0 \\ 0 & \ddots & 0 \\ 0 & 0 & M_n \end{bmatrix}$$

$$C \triangleq \text{diag}(C_1, \dots, C_n)$$

$$K \triangleq \text{diag}(K_1, \dots, K_n)$$

$$q \triangleq \begin{bmatrix} q_1 \\ \vdots \\ q_n \end{bmatrix}, \quad B \triangleq \begin{bmatrix} B_1 \\ \vdots \\ B_n \end{bmatrix}, \quad F \triangleq [F_1 \ \dots \ F_n], \quad G \triangleq [G_1 \ \dots \ G_n],$$

where f is the force vector dependent on time and g is the vector of internal forces at the interface.

Two interfaced components share a set of DOFs in the global finite element mesh q : the subset N_1 of DOFs from the first component coincides with the subset N_2 of DOFs from the second component. The coupling between the two components is rigid only if:

- The displacements q at the shared DOFs are the same for both components.

$$q(N_1) = q(N_2)$$

- The forces g one component exerts on the other are opposite (by the action/reaction principle).

$$g(N_1) + g(N_2) = 0$$

This relation can be summarized as:

$$M \ddot{q} + C \dot{q} + K q = B u + g, \quad H q = 0, \quad g = -H^T \lambda,$$

where H is a localisation matrix with entries 0, 1, or -1. The equation $Hq = 0$ is equivalent to $q(N_1) = q(N_2)$, and the equation $g = -H^T \lambda$ is equivalent to $g(N_1) = -\lambda$ and $g(N_2) = \lambda$. These equations can be combined in the differential-algebraic equation (DAE) form:

$$\begin{bmatrix} M & 0 \\ 0 & 0 \end{bmatrix} \begin{bmatrix} \ddot{q} \\ \ddot{\lambda} \end{bmatrix} + \begin{bmatrix} C & 0 \\ 0 & 0 \end{bmatrix} \begin{bmatrix} \dot{q} \\ \dot{\lambda} \end{bmatrix} + \begin{bmatrix} K & H^T \\ H & 0 \end{bmatrix} \begin{bmatrix} q \\ \lambda \end{bmatrix} = \begin{bmatrix} B \\ 0 \end{bmatrix} u$$

$$y = [F \ 0] \begin{bmatrix} q \\ \lambda \end{bmatrix} + [G \ 0] \begin{bmatrix} \dot{q} \\ \dot{\lambda} \end{bmatrix} + Du.$$

This DAE model is called the *dual assembly* model of the overall structure. While the principle was explained for two components, this model can accommodate multiple interfaces, including interfaces involving more than two components.

Nonrigid Interface

In non-rigid interfaces, the displacements $q_1(N_1)$ and $q_2(N_2)$ are allowed to differ and the internal force is given by:

$$\lambda = K_i \delta + C_i \dot{\delta}, \quad \delta \triangleq Hq = q_1(N_1) - q_2(N_2).$$

This models spring-damper-like connections between DOFs N_1 in the first component and DOFs N_2 in the second component. Going from rigid to non-rigid connection eliminates the algebraic constraints $Hq = 0$ and explicates the internal forces. Then, eliminate λ to obtain:

$$M \ddot{q} + (C + H^T C_i H) \dot{q} + (K + H^T K_i H) q = 0, \quad y = Fq + G\dot{q} + Du.$$

This is the set of the *primal-assembly* equations for non-rigid coupling form that remains symmetric when the uncoupled model is symmetric. A drawback of this form is that the coupling terms $H^T C_i H$ and $H^T K_i H$ may cause fill-in. To avoid this, `interface` instead constructs the dual-assembly form:

$$\begin{bmatrix} M & 0 & 0 \\ 0 & 0 & 0 \\ 0 & 0 & 0 \end{bmatrix} \begin{bmatrix} \ddot{q} \\ \ddot{\delta} \\ \ddot{\lambda} \end{bmatrix} + \begin{bmatrix} C & 0 & 0 \\ 0 & C_i & 0 \\ 0 & 0 & 0 \end{bmatrix} \begin{bmatrix} \dot{q} \\ \dot{\delta} \\ \dot{\lambda} \end{bmatrix} + \begin{bmatrix} K & 0 & H^T \\ 0 & K_i & -I \\ H & -I & 0 \end{bmatrix} \begin{bmatrix} q \\ \delta \\ \lambda \end{bmatrix} = \begin{bmatrix} B \\ 0 \\ 0 \end{bmatrix} u.$$

Primal-Assembly Model

For rigid interfaces, *primal assembly* consists of eliminating half of the redundant DOFs associated with the following constraint.

$$q(N_1) = q(N_2)$$

If $Hq = 0$ is the matrix expression of this constraint, this amounts to writing $q = Lq_r$. Here, q_r is the set of independent (free) DOFs and L spans the null space of H .

$$HL = 0$$

Since the nonzero part of H is of the form $(I -I)$, L can be constructed by starting from the identity matrix of size q , moving the block (N_2, N_2) to the position (N_2, N_1) , and deleting the zero columns with index N_2 . Using $q = Lq_r$, the equations

$$\begin{aligned} M\ddot{q} + C\dot{q} + Kq &= Bu + g, \quad g = -H^T\lambda \\ y &= Fq + G\dot{q} + Du \end{aligned}$$

become

$$ML\ddot{q}_r + CL\dot{q}_r + KLq_r = Bu + g, \quad y = FLq_r + GL\dot{q}_r + Du.$$

Using $L^TH^T = (HL)^T = 0$, the first part of equation can be projected onto the range of L by premultiplying by L^T :

$$(L^TML)\ddot{q}_r + (L^TCL)\dot{q}_r + (L^TKL)q_r = L^TBu, \quad y = FLq_r + GL\dot{q}_r + Du.$$

This is the *primal-assembly* model of the interface. It has $2N_1$ fewer algebraic variables than its dual-assembly counterpart, at the expense of potential fill-in in the reduced M , C , and K .

For the non-rigid interfaces, use the explicit expression for λ and g to obtain the primal assembly equations:

$$M\ddot{q} + (C + H^TC_iH)\dot{q} + (K + H^TK_iH)q = 0, \quad y = Fq + G\dot{q} + Du.$$

Here the interface damping and stiffness modify C and K , and the number of DOFs remains unchanged.

Version History

Introduced in R2020b

See Also

[mechss](#) | [xsort](#) | [showStateInfo](#)

Topics

“Sparse Model Basics”

“Rigid Assembly of Model Components”

interp

Interpolate FRD model

Syntax

```
isys = interp(sys, freqs)
```

Description

`isys = interp(sys, freqs)` interpolates the frequency response data contained in the FRD model `sys` at the frequencies `freqs`. `interp`, which is an overloaded version of the MATLAB function `interp`, uses linear interpolation and returns an FRD model `isys` containing the interpolated data at the new frequencies `freqs`. If `sys` is an IDFRD model (requires System Identification Toolbox software), the noise spectrum, if non-empty, is also interpolated. The response and noise covariance data, if available, are also interpolated.

You should express the frequency values `freqs` in the same units as `sys.frequency`. The frequency values must lie between the smallest and largest frequency points in `sys` (extrapolation is not supported).

Version History

Introduced before R2006a

See Also

`freqresp` | `frd`

inv

Invert models

Syntax

```
inv
inv(sys, 'min')
```

Description

inv inverts the input/output relation

$$y = G(s)u$$

to produce the model with the transfer matrix $H(s) = G(s)^{-1}$.

$$u = H(s)y$$

This operation is defined only for square systems (same number of inputs and outputs) with an invertible feedthrough matrix D . inv handles both continuous- and discrete-time systems.

inv(sys, 'min') inverts sys to eliminate the extra states and obtain a model with as many states as sys or A respectively. For ss, genss and uss models, the inverse model is returned in implicit form by default. This option is ignored for sparse models because it typically destroys sparsity. Use isproper or ss(sys, 'explicit') to extract an explicit model if desired.

Examples

Consider

$$H(s) = \begin{bmatrix} 1 & \frac{1}{s+1} \\ 0 & 1 \end{bmatrix}$$

At the MATLAB prompt, type

```
H = [1 tf(1,[1 1]);0 1]
Hi = inv(H)
```

to invert it. These commands produce the following result.

Transfer function from input 1 to output...

```
#1: 1
```

```
#2: 0
```

Transfer function from input 2 to output...

```
-1
#1: -----
    s + 1
```

```
#2: 1
```

You can verify that

```
H * Hi
```

is the identity transfer function (static gain I).

Limitations

Do not use `inv` to model feedback connections such as

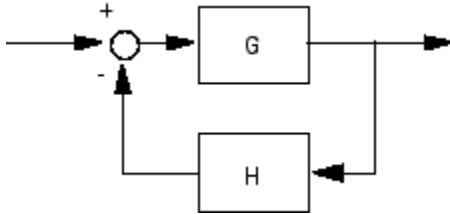

While it seems reasonable to evaluate the corresponding closed-loop transfer function $(I + GH)^{-1}G$ as

```
inv(1+g*h) * g
```

this typically leads to nonminimal closed-loop models. For example,

```
g = zpk([],1,1)
h = tf([2 1],[1 0])
cloop = inv(1+g*h) * g
```

yields a third-order closed-loop model with an unstable pole-zero cancellation at $s = 1$.

```
cloop
```

```
Zero/pole/gain:
```

```
      s (s-1)
```

```
-----
(s-1) (s^2 + s + 1)
```

Use feedback to avoid such pitfalls.

```
cloop = feedback(g,h)
```

```
Zero/pole/gain:
```

```
      s
```

```
-----
(s^2 + s + 1)
```

Version History

Introduced before R2006a

iopzmap

Plot pole-zero map for I/O pairs of model

Syntax

```
iopzmap(sys)  
iopzmap(sys1,sys2,...)
```

Description

`iopzmap(sys)` computes and plots the poles and zeros of each input/output pair of the dynamic system model `sys`. The poles are plotted as x's and the zeros are plotted as o's.

`iopzmap(sys1,sys2,...)` shows the poles and zeros of multiple models `sys1,sys2,...` on a single plot. You can specify distinctive colors for each model, as in `iopzmap(sys1,'r',sys2,'y',sys3,'g')`.

The functions `sgrid` or `zgrid` can be used to plot lines of constant damping ratio and natural frequency in the s or z plane.

For model arrays, `iopzmap` plots the poles and zeros of each model in the array on the same diagram.

Examples

Pole-Zero Map for MIMO System

Create a one-input, two-output dynamic system.

```
H = [tf(-5,[1 -1]); tf([1 -5 6],[1 1 0])];
```

Plot a pole-zero map.

```
iopzmap(H)
```

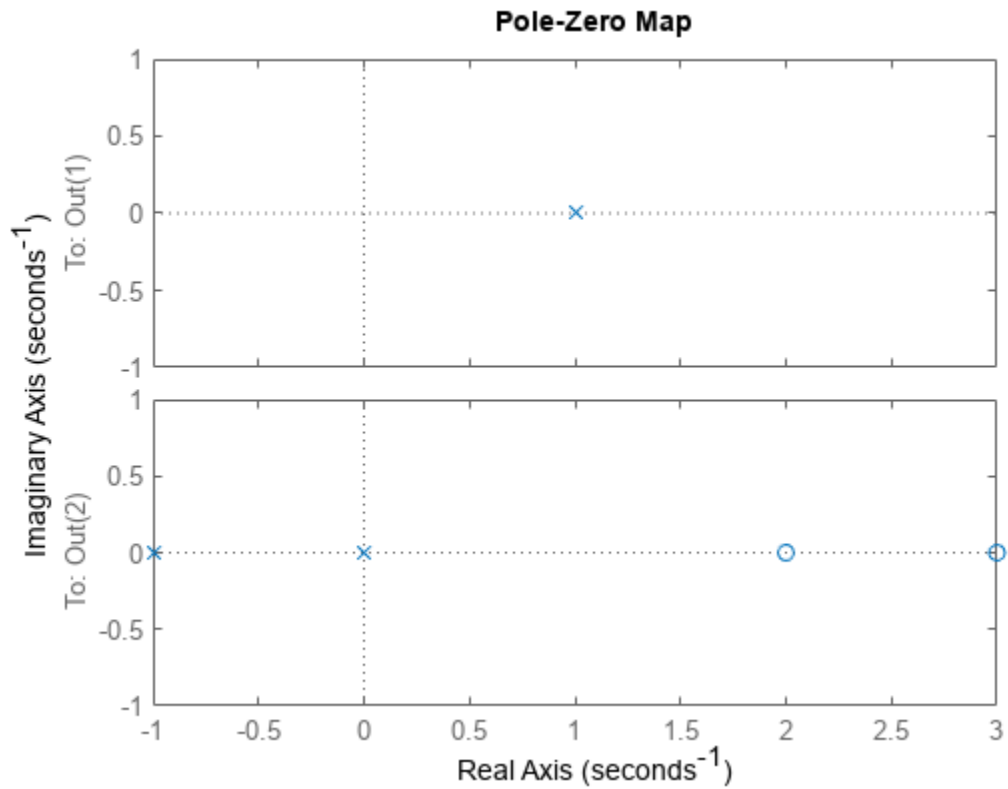



`iopzmap` generates a separate map for each I/O pair in the system.

Pole-Zero Map of Identified Model

View the poles and zeros of an over-parameterized state-space model estimated from input-output data. (Requires System Identification Toolbox™).

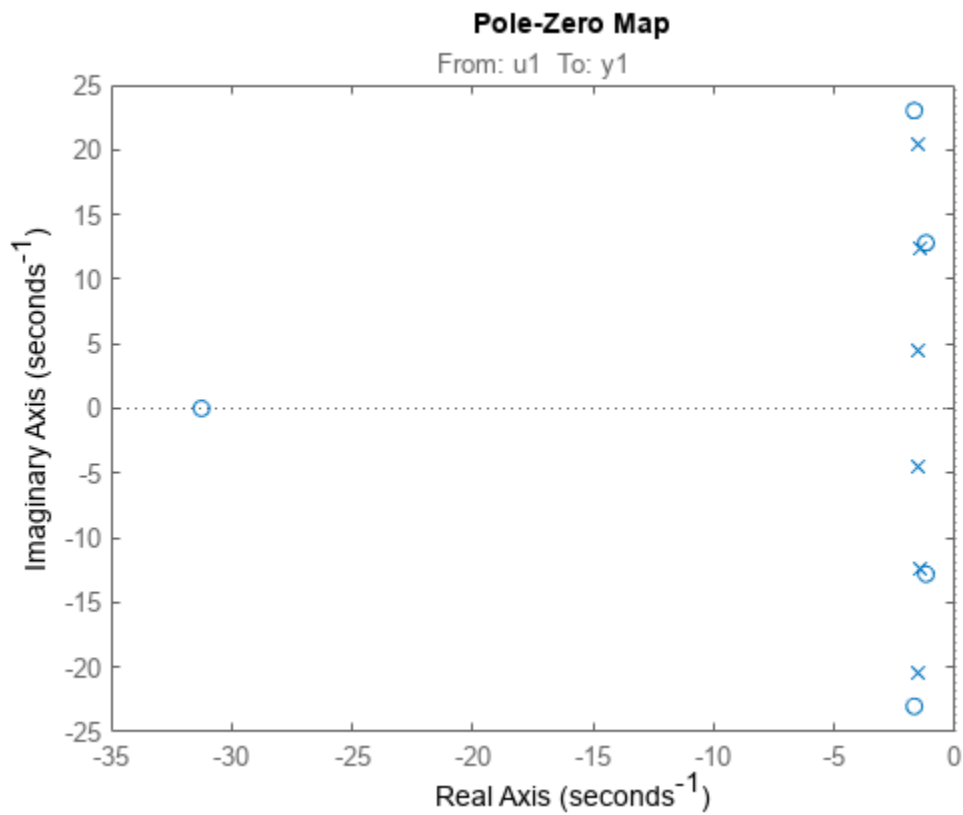
```
load iddata1
sys = ssest(z1,6,ssestOptions('focus','simulation'));
iopzmap(sys)
```



The plot shows that there are two pole-zero pairs that almost overlap, which hints are their potential redundancy.

Tips

For additional options for customizing the appearance of the pole-zero plot, use `iopzplot`.

Version History

Introduced before R2006a

See Also

`pzmap` | `pole` | `zero` | `sgrid` | `zgrid` | `iopzplot`

iopzplot

Plot pole-zero map for I/O pairs with additional plot customization options

Syntax

```
h = iopzplot(sys)
h = iopzplot(sys1,sys2,...,sysN)
h = iopzplot(sys1,LineStyle1,...,sysN,LineStyleN)
h = iopzplot(ax,...)
h = iopzplot(...,plotoptions)
```

Description

`iopzplot` lets you plot pole-zero maps for input/output pairs with a broader range of plot customization options than `iopzmap`. You can use `iopzplot` to obtain the plot handle and use it to customize the plot, such as modify the axes labels, limits and units. You can also use `iopzplot` to draw a pole-zero plot on an existing set of axes represented by an axes handle. To customize an existing plot using the plot handle:

- 1 Obtain the plot handle
- 2 Use `getoptions` to obtain the option set
- 3 Update the plot using `setoptions` to modify the required options

For more information, see “Customizing Response Plots from the Command Line”. To create pole-zero maps with default options or to extract pole-zero data, use `iopzmap`.

`h = iopzplot(sys)` plots the poles and zeros of each input/output pair of the dynamic system model `sys` and returns the plot handle `h` to the plot. `x` and `o` indicates poles and zeros respectively.

`h = iopzplot(sys1,sys2,...,sysN)` displays the poles and transmission zeros of multiple models on a single plot. You can specify distinct colors for each model individually.

`h = iopzplot(sys1,LineStyle1,...,sysN,LineStyleN)` sets the line style, marker type, and color for the plot of each system. All systems must have the same number of inputs and outputs to use this syntax.

`h = iopzplot(ax,...)` plots into the axes specified by `ax` instead of the current axis `gca`.

`h = iopzplot(...,plotoptions)` plots the poles and transmission zeros with the options specified in `plotoptions`. For more information on the ways to change properties of your plots, see “Ways to Customize Plots”.

Examples

Change I/O Grouping on Pole/Zero Map

Create a pole/zero map of a two-input, two-output dynamic system.

```
sys = rss(3,2,2);  
h = iopzplot(sys);
```

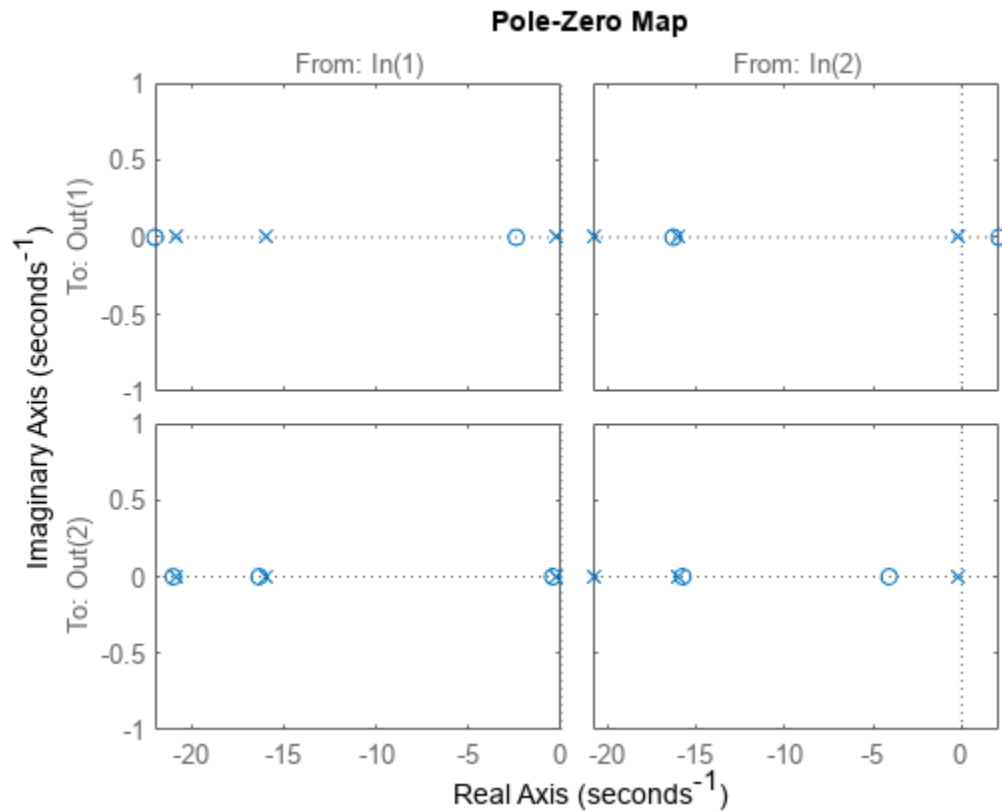

By default, the plot displays the poles and zeros of each I/O pair on its own axis. Use the plot handle to view all I/Os on a single axis.

```
setoptions(h, 'IOGrouping', 'all')
```

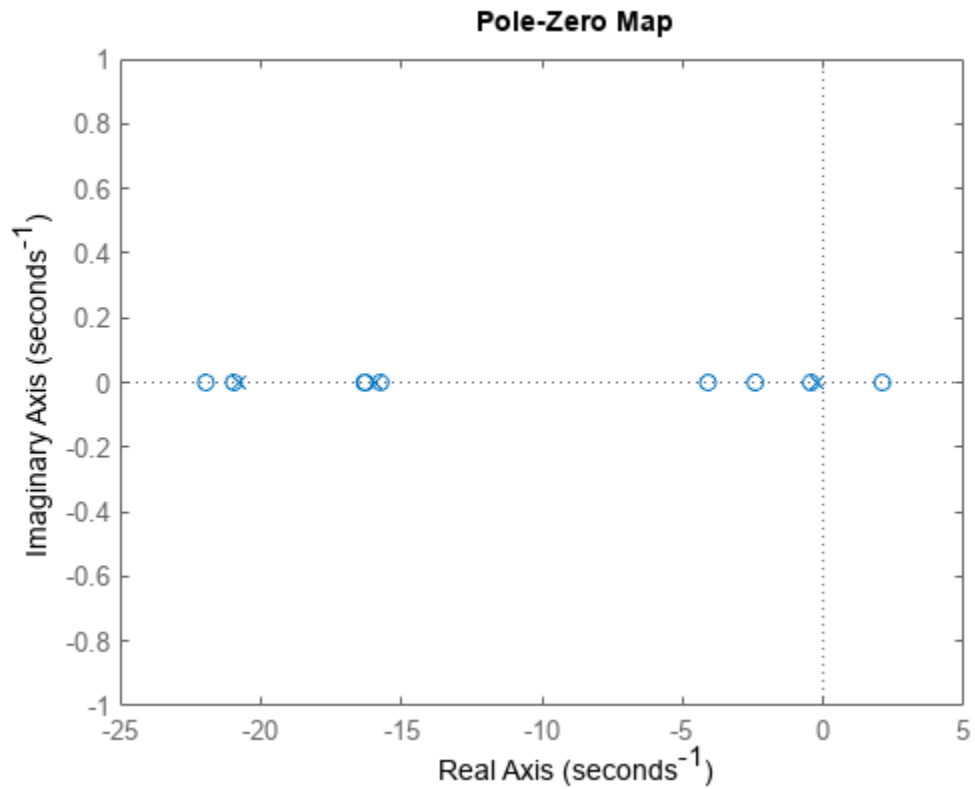

Use Pole-Zero Map to Examine Identified Model

View the poles and zeros of a sixth-order state-space model estimated from input-output data. Use the plot handle to display the confidence intervals of the identified model's pole and zero locations.

```
load iddata1
sys = ssest(z1,6,ssestOptions('focus','simulation'));
h = iopzplot(sys);
showConfidence(h)
```

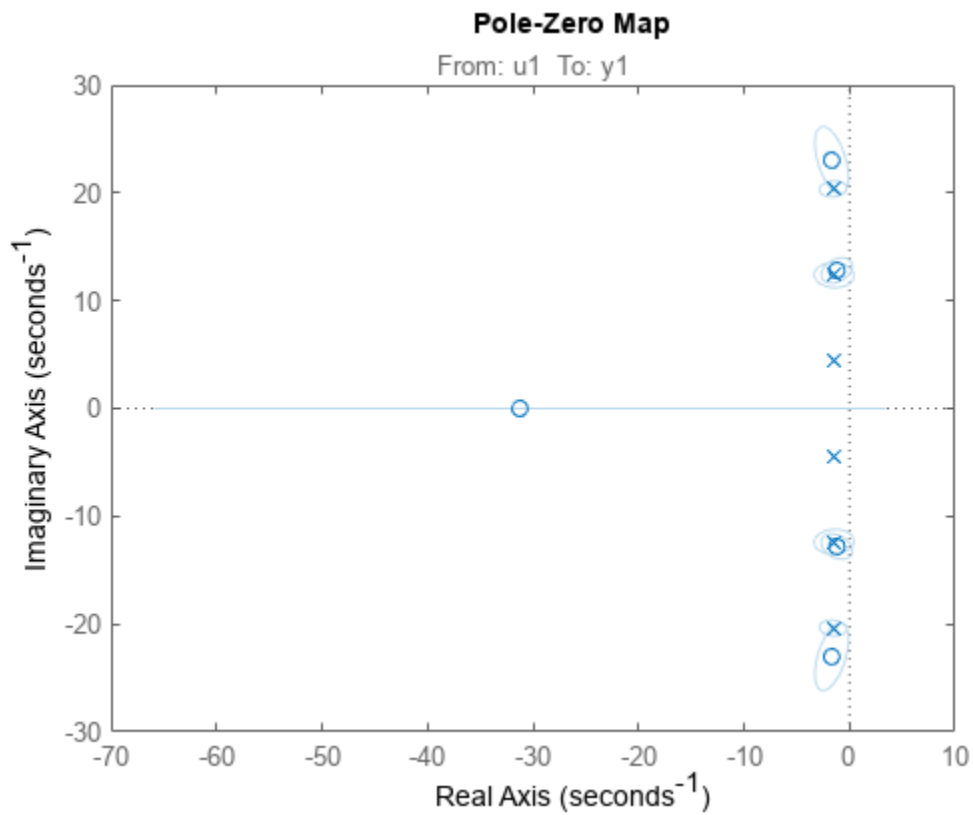

There is at least one pair of complex-conjugate poles whose locations overlap with those of a complex zero, within the 1- σ confidence region. This suggests their redundancy. Hence, a lower (4th) order model might be more robust for the given data.

```
sys2 = ssest(z1,4,ssestOptions('focus','simulation'));
h = iopzplot(sys,sys2);
showConfidence(h)
legend('6th-order','4th-order')
axis([-20, 10 -30 30])
```

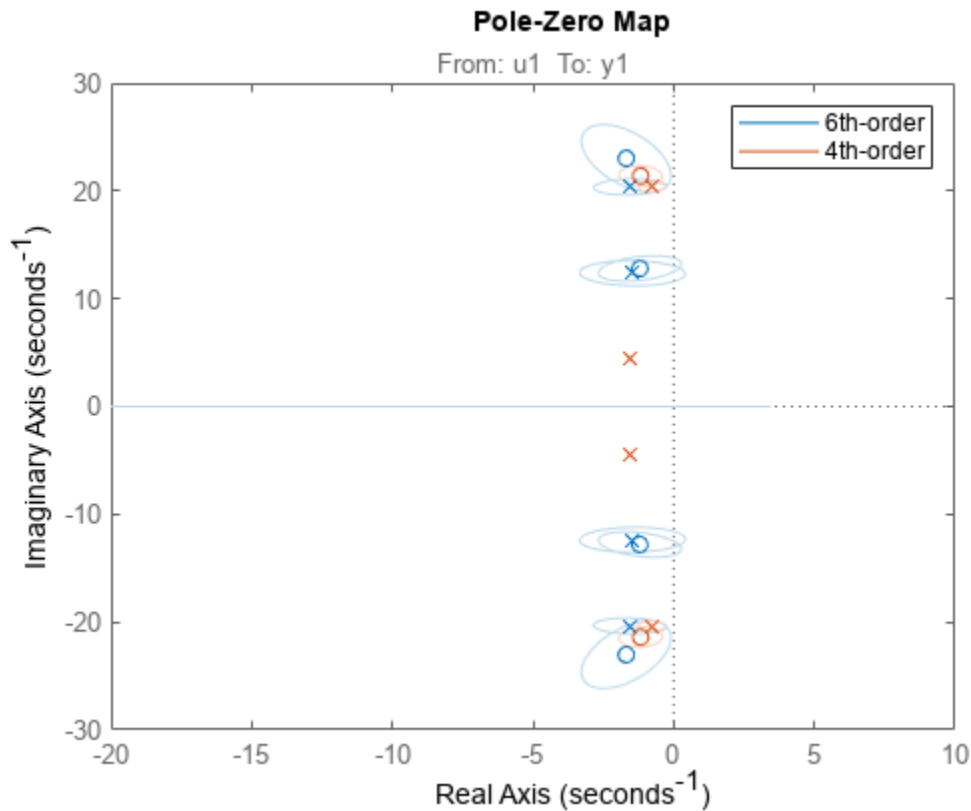

The fourth-order model `sys2` shows less variability in the pole-zero locations.

Input Arguments

sys — Dynamic system

dynamic system model | model array

Dynamic system, specified as a SISO or MIMO dynamic system model, or an array of SISO or MIMO dynamic system models. Dynamic systems that you can use include continuous-time or discrete-time numeric LTI models such as `tf`, `zpk`, or `ss` models.

If `sys` is a generalized state-space model `genss` or an uncertain state-space model `uss`, `pzplot` returns the poles and transmission zeros of the current or nominal value of `sys`. If `sys` is an array of models, `pzplot` plots the poles and zeros of each model in the array on the same diagram.

LineStyleSpec — Line style, marker, and color

character vector | string

Line style, marker, and color, specified as a character vector or string containing symbols. The symbols can appear in any order. You do not need to specify all three characteristics (line style, marker, and color). For example, if you omit the line style and specify the marker, then the plot shows only the marker and no line.

Example: `'--or'` is a red dashed line with circle markers

Line Style	Description
-	Solid line
--	Dashed line
:	Dotted line
-.	Dash-dot line

Marker	Description
'o'	Circle
'+'	Plus sign
'*'	Asterisk
'.'	Point
'x'	Cross
'_'	Horizontal line
' '	Vertical line
's'	Square
'd'	Diamond
'^'	Upward-pointing triangle
'v'	Downward-pointing triangle
'>'	Right-pointing triangle
'<'	Left-pointing triangle
'p'	Pentagram
'h'	Hexagram

Color	Description
y	yellow
m	magenta
c	cyan
r	red
g	green
b	blue
w	white
k	black

ax — Axes handle

axes object

Axes handle, specified as an axes object. If you do not specify the axes object, then `pzplot` uses the current axes `gca` to plot the poles and zeros of the system.

plotoptions — Pole-zero plot options

options object

Pole-zero plot options, specified as an options object. See `pzoptions` for a list of available plot options.

Output Arguments

h — Pole-zero plot options handle

scalar

Pole-zero plot options handle, returned as a scalar. Use `h` to query and modify properties of your pole-zero plot. You can use this handle to customize the plot with the `getoptions` and `setoptions` commands.

Tips

- Use `sgrid` or `zgrid` to plot lines of constant damping ratio and natural frequency in the s - or z -plane.

Version History

Introduced before R2006a

See Also

`getoptions` | `iopzmap` | `setoptions`

Topics

“Ways to Customize Plots”

isct

Determine if dynamic system model is in continuous time

Syntax

```
bool = isct(sys)
```

Description

`bool = isct(sys)` returns a logical value of 1 (`true`) if the dynamic system model `sys` is a continuous-time model. The function returns a logical value of 0 (`false`) otherwise.

Input Arguments

sys

Dynamic system model or array of such models.

Output Arguments

bool

Logical value indicating whether `sys` is a continuous-time model.

`bool = 1 (true)` if `sys` is a continuous-time model (`sys.Ts = 0`). If `sys` is a discrete-time model, `bool = 0 (false)`.

For a static gain, both `isct` and `isdT` return `true` unless you explicitly set the sample time to a nonzero value. If you do so, `isdT` returns `true` and `isct` returns `false`.

For arrays of models, `bool` is `true` if the models in the array are continuous.

Version History

Introduced in R2007a

See Also

`isdT` | `isstable`

isdt

Determine if dynamic system model is in discrete time

Syntax

```
bool = isdt(sys)
```

Description

`bool = isdt(sys)` returns a logical value of 1 (`true`) if the dynamic system model `sys` is a discrete-time model. The function returns a logical value of 0 (`false`) otherwise.

Input Arguments

sys

Dynamic system model or array of such models.

Output Arguments

bool

Logical value indicating whether `sys` is a discrete-time model.

`bool = 1 (true)` if `sys` is a discrete-time model (`sys.Ts ≠ 0`). If `sys` is a continuous-time model, `bool = 0 (false)`.

For a static gain, both `isct` and `isdt` return `true` unless you explicitly set the sample time to a nonzero value. If you do so, `isdt` returns `true` and `isct` returns `false`.

For arrays of models, `bool` is `true` if the models in the array are discrete.

Version History

Introduced in R2007a

See Also

`isct` | `isstable`

isempty

Determine whether dynamic system model is empty

Syntax

```
isempty(sys)
```

Description

`isempty(sys)` returns a logical value of 1 (`true`) if the dynamic system model `sys` has no input or no output, and a logical value of 0 (`false`) otherwise. Where `sys` is a `frd` model, `isempty(sys)` returns 1 when the frequency vector is empty. Where `sys` is a model array, `isempty(sys)` returns 1 when the array has empty dimensions or when the LTI models in the array are empty.

Examples

Determine Whether Dynamic Model Is Empty

Create a continuous-time state-space model with 1 input and no outputs. In this example, specify the A and B matrices as 1 and 2, respectively.

```
sys1 = ss(1,2,[],[]);
```

Determine whether `sys1` is empty.

```
isempty(sys1)
```

```
ans = logical  
     1
```

The `isempty` command returns 1 because the system does not have any outputs.

Similarly, `isempty` returns 1 for an empty transfer function.

```
isempty(tf)
```

```
ans = logical  
     1
```

Now create a state-space model with 1 input and 1 output. In this example, specify the A, B, C, and D matrices as 1, 2, 3, and 4, respectively.

```
sys2 = ss(1,2,3,4);
```

Determine whether `sys2` is empty.

```
isempty(sys2)
```

```
ans = logical  
     0
```

The command returns 0 because the system has inputs and outputs.

Version History

Introduced before R2006a

See Also

`issiso` | `size`

isfinite

Determine if model has finite coefficients

Syntax

```
B = isfinite(sys)
B = isfinite(sys,'elem')
```

Description

`B = isfinite(sys)` returns a logical value of 1 (`true`) if the model `sys` has finite coefficients, and a logical value of 0 (`false`) otherwise. If `sys` is a model array, then `B = 1` if all models in `sys` have finite coefficients.

`B = isfinite(sys,'elem')` checks each model in the model array `sys` and returns a logical array of the same size as `sys`. The logical array indicates which models in `sys` have finite coefficients.

Examples

Check Model for Finite Coefficients

Create model and check whether its coefficients are all finite.

```
sys = rss(3);
B = isfinite(sys)
```

```
B = logical
    1
```

The model, `sys`, has finite coefficients.

Check Each Model in Array

Create a 1-by-5 array of models, and check each model for finite coefficients.

```
sys = rss(2,2,2,1,5);
B = isfinite(sys,'elem')
```

```
B = 1x5 logical array
    1    1    1    1    1
```

`isfinite` checks each model in the model array, `sys`, and returns a logical array indicating which models have all finite coefficients.

Input Arguments

sys — Model or array to check

input-output model | model array

Model or array to check, specified as an input-output model or model array. Input-output models include dynamic system models such as numeric LTI models and generalized models. Input-output models also include static models such as tunable parameters or generalized matrices.

Output Arguments

B — Flag indicating whether model has finite coefficients

logical | logical array

Flag indicating whether model has finite coefficients, returned as a logical value or logical array.

Version History

Introduced in R2013a

See Also

isreal

isParametric

Determine if model has tunable parameters

Syntax

```
bool = isParametric(M)
```

Description

`bool = isParametric(M)` returns a logical value of 1 (`true`) if the model `M` contains parametric (tunable) “Control Design Blocks”. The function returns a logical value of 0 (`false`) otherwise.

Input Arguments

M

A Dynamic System model or Static model, or an array of such models.

Output Arguments

bool

Logical value indicating whether `M` contains tunable parameters.

`bool = 1 (true)` if the model `M` contains parametric (tunable) “Control Design Blocks” such as `realp` or `tunableSS`. If `M` does not contain parametric Control Design Blocks, `bool = 0 (false)`.

Version History

Introduced in R2011a

See Also

`nblocks`

Topics

“Control Design Blocks”
“Dynamic System Models”
“Static Models”

isPassive

Check passivity of linear systems

Syntax

```
pf = isPassive(G)
pf = isPassive(G,nu,rho)
[pf,R] = isPassive(G,___)
```

Description

`pf = isPassive(G)` returns a logical value of 1 (`true`) if the dynamic system model `G` is passive, and a logical value of 0 (`false`) otherwise. A system is passive if all its I/O trajectories $(u(t),y(t))$ satisfy:

$$\int_0^T y(t)^T u(t) dt > 0,$$

for all $T > 0$. Equivalently, a system is passive if its frequency response is positive real, which means that for all $\omega > 0$,

$$G(j\omega) + G(j\omega)^H > 0$$

(or the discrete-time equivalent). If `G` is a model array, then `isPassive` returns a logical array of the same array dimensions as `G`, where each entry in the array reflects the passivity of the corresponding entry in `G`.

For more information about the notion of passivity, see “About Passivity and Passivity Indices”.

`pf = isPassive(G,nu,rho)` returns 1 (`true`) if `G` is passive with index `nu` at the inputs, and index `rho` at the outputs. Such systems satisfy:

$$\int_0^T y(t)^T u(t) dt > \nu \int_0^T u(t)^T u(t) dt + \rho \int_0^T y(t)^T y(t) dt,$$

for all $T > 0$.

- Use `rho = 0` to check whether a system is input passive with index `nu` at the inputs.
- Use `nu = 0` to check whether a system is output passive with index `rho` at the outputs.

For more information about input and output passivity, see “About Passivity and Passivity Indices”.

`[pf,R] = isPassive(G,___)` also returns the relative index for the corresponding passivity bound (see `getPassiveIndex`). `R` measures the amount by which the passivity property is satisfied ($R < 1$) or violated ($R > 1$). You can use this syntax with any of the previous combinations of input arguments.

Examples

Check Passivity of Dynamic System

Test whether the following transfer function is passive:

$$G(s) = \frac{s+1}{s+2}.$$

```
G = tf([1,1],[1,2]);
[pf,R] = isPassive(G)
```

```
pf = logical
      1
```

```
R = 0.3333
```

pf = 1 indicates that *G* is passive. *R* = 0.3333 indicates that *R* has a relative excess of passivity.

Check Input and Output Passivity

Test whether the transfer function *G* is input passive with index 0.25. To do so, use *nu* = 0.25 and *rho* = 0.

```
G = tf([1,1],[1,2]);
[pfin,Rin] = isPassive(G,0.25,0)
```

```
pfin = logical
       1
```

```
Rin = 0.6096
```

The result shows that *G* is input passive with this *nu* value and has some excess passivity.

Test whether *G* is output passive with index 2.

```
[pfout,Rout] = isPassive(G,0,2)
```

```
pfout = logical
        0
```

```
Rout = 2.6180
```

Here, the result *pfout* = 0 shows that *G* is not output passive with this *rho* value. The *R* value gives a relative measure of the shortage of passivity.

Check Passivity of Models in Array

You can use `isPassive` to evaluate the passivity of multiple models in a model array simultaneously. For this example, generate a random array of transfer function models.

```
G = rss(3,1,1,1,5);
```

G is a 1-by-5 array of 3-state SISO models. Check the passivity of all the models in G.

```
[pf,R] = isPassive(G)
```

```
pf = 1x5 logical array
```

```
    0    0    0    1    0
```

```
R = 1x5
```

```
    35.3759         Inf         Inf    0.1130    4.3096
```

pf and R are also 1-by-5 arrays. Each pf entry indicates whether the corresponding model in G is passive. Likewise, each R value gives the relative excess or shortage of passivity in the corresponding model in G. For instance, examine the passivity of the second entry in G, and compare the result with the second entries in pf and R.

```
[pf2,R2] = isPassive(G(:, :, 2))
```

```
pf2 = logical
     0
```

```
R2 = Inf
```

Input Arguments

G — Model to analyze

dynamic system model | model array

Model to analyze for passivity, specified as a dynamic system model such as a `tf`, `ss`, or `genss` model. G can be MIMO, if the number of inputs equals the number of outputs. G can be continuous or discrete. If G is a generalized model with tunable or uncertain blocks, `isPassive` evaluates passivity of the current, nominal value of G.

nu — Input passivity index

0 (default) | real scalar

Input passivity index, specified as a real scalar value. Use nu and rho to specify particular passivity bounds. To check whether a system is passive with a particular index at the inputs, set nu to that value and set rho = 0.

rho — Output passivity index

0 (default) | real scalar

Output passivity index, specified as a real scalar value. Use nu and rho to specify particular passivity bounds. To check whether a system is passive with a particular passivity index at the outputs, set rho to that value and set nu = 0.

Output Arguments

pf — Passivity indicator

1 (true) | 0 (false) | logical array

Passivity indicator, returned as a boolean value:

- 1 (`true`) if G is passive.
- 0 (`false`) if G is not passive.

If you specify input and output passivity indices ν and ρ , then `pf` indicates passivity with respect to the corresponding passivity bound.

If G is a model array, then `pf` is an array of the same size, where `pf(k)` indicates the passivity of the k th entry in G , `G(:, :, k)`.

R — Relative passivity index

positive real scalar

Relative passivity index, returned as a positive real scalar. R measures the excess ($R < 1$) or shortage ($R > 1$) of passivity in the system.

If you specify $\nu \neq 0$ or $\rho \neq 0$, then R measures how much the specified passivity properties are satisfied or violated.

For more information about the notion of relative passivity index, see “About Passivity and Passivity Indices”.

Version History

Introduced in R2016a

See Also

`getPassiveIndex` | `passiveplot` | `getSectorIndex` | `getSectorCrossover` | `getPeakGain` | `sectorplot`

Topics

“Passivity Indices”

“About Passivity and Passivity Indices”

isproper

Determine if dynamic system model is proper

Syntax

```
B = isproper(sys)
B = isproper(sys,'elem')
[B,sysr] = isproper(sys)
```

Description

`B = isproper(sys)` returns a logical value of 1 (`true`) if the dynamic system model `sys` is proper and a logical value of 0 (`false`) otherwise.

A proper model has relative degree ≤ 0 and is causal. SISO transfer functions and zero-pole-gain models are proper if the degree of their numerator is less than or equal to the degree of their denominator (in other words, if they have at least as many poles as zeroes). MIMO transfer functions are proper if all their SISO entries are proper. Regular state-space models (state-space models having no E matrix) are always proper. A descriptor state-space model that has an invertible E matrix is always proper. A descriptor state-space model having a singular (non-invertible) E matrix is proper if the model has at least as many poles as zeroes.

If `sys` is a model array, then `B` is 1 if all models in the array are proper.

`B = isproper(sys,'elem')` checks each model in a model array `sys` and returns a logical array of the same size as `sys`. The logical array indicates which models in `sys` are proper.

`[B,sysr] = isproper(sys)` also returns an equivalent model `sysr` with fewer states (reduced order) and a non-singular E matrix, if `sys` is a proper descriptor state-space model with a non-invertible E matrix. If `sys` is not proper, `sysr = sys`.

Examples

Examine Whether Models are Proper

Create a SISO continuous-time transfer function, $H_1 = s$

```
H1 = tf([1 0],1);
```

Check whether H1 is proper.

```
B1 = isproper(H1)
```

```
B1 = logical
     0
```

SISO transfer functions are proper if the degree of their numerator is less than or equal to the degree of their denominator. That is, if the transfer function has at least as many poles as zeroes. Since `H1` has one zero and no poles, the `isproper` command returns 0.

Now create a transfer function with one pole and one zero, $H_2 = s/(s + 1)$

```
H2 = tf([1 0],[1 1]);
```

Check whether H2 is proper.

```
B2 = isproper(H2)
```

```
B2 = logical  
     1
```

Since H2 has equal number of poles and zeros, `isproper` returns 1.

Compute Equivalent Lower-Order Model

Combining state-space models sometimes yields results that include more states than necessary. Use `isproper` to compute an equivalent lower-order model.

```
H1 = ss(tf([1 1],[1 2 5]));  
H2 = ss(tf([1 7],[1]));  
H = H1*H2;  
size(H)
```

State-space model with 1 outputs, 1 inputs, and 4 states.

H is proper and reducible. `isproper` returns the reduced model.

```
[isprop,Hr] = isproper(H);  
size(Hr)
```

State-space model with 1 outputs, 1 inputs, and 2 states.

H and Hr are equivalent, as a Bode plot demonstrates.

```
bodeplot(H,Hr,'r--')  
legend('original','reduced')
```

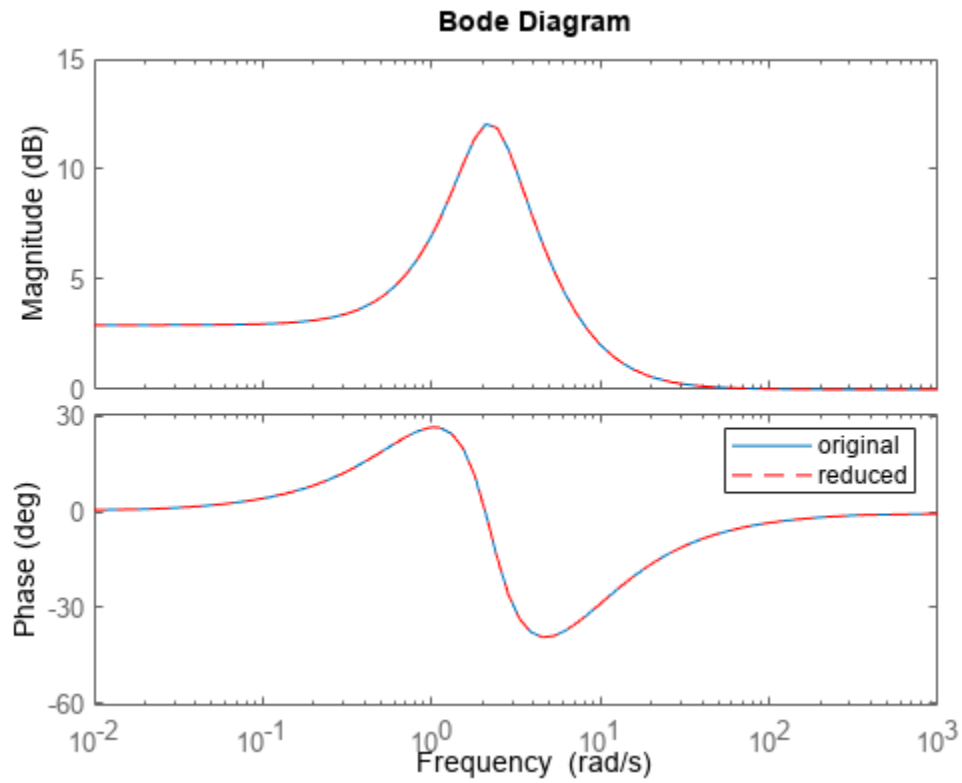

Version History

Introduced before R2006a

References

- [1] Varga, András. "Computation of irreducible generalized state-space realizations." *Kybernetika* 26.2 (1990): 89-106.

See Also

ss | dss

isreal

Determine if model has real-valued coefficients

Syntax

```
B = isreal(sys)
B = isreal(sys,'elem')
```

Description

`B = isreal(sys)` returns a logical value of 1 (`true`) if the model `sys` has real-valued coefficients, and a logical value of 0 (`false`) otherwise. If `sys` is a model array, then `B = 1` if all models in `sys` have real-valued coefficients.

`B = isreal(sys,'elem')` checks each model in the model array `sys` and returns a logical array of the same size as `sys`. The logical array indicates which models in `sys` have real coefficients.

Examples

Check Model for Real-Valued Coefficients

Create a model and check whether its coefficients are all real-valued.

```
sys = rss(3);
B = isreal(sys)
```

```
B = logical
    1
```

The model, `sys`, has real-valued coefficients.

Check Model Array for Real-Valued Coefficients

Create a 1-by-5 array of models, and check each model for real-valued coefficients.

```
sys = rss(2,2,2,1,5);
B = isreal(sys,'elem')
```

```
B = 1x5 logical array
    1    1    1    1    1
```

`isreal` checks each model in the model array, `sys`, and returns a logical array indicating which models have all real-valued coefficients.

Input Arguments

sys — Model or array to check

input-output model | model array

Model or array to check, specified as an input-output model or model array. Input-output models include dynamic system models such as numeric LTI models and generalized models. Input-output models also include static models such as tunable parameters or generalized matrices.

Output Arguments

B — Flag indicating whether model has real-valued coefficients

logical | logical array

Flag indicating whether model has real-valued coefficients, returned as a logical value or logical array.

Version History

Introduced in R2013a

See Also

isfinite

isstable

Determine if dynamic system model is stable

Syntax

```
B = isstable(sys)
B = isstable(sys,'elem')
```

Description

`B = isstable(sys)` returns a logical value of 1 (`true`) if the dynamic system model `sys` has stable dynamics, and a logical value of 0 (`false`) otherwise. If `sys` is a model array, then the function returns 1 only if all the models in `sys` are stable.

`isstable` returns a logical value of 1 (`true`) for stability of a dynamic system if:

- In continuous-time systems, all the poles lie in the open left half of the complex plane.
- In discrete-time systems, all the poles lie inside the open unit disk.

`isstable` is supported only for analytical models with a finite number of poles.

`B = isstable(sys,'elem')` returns a logical array of the same dimensions as the model array `sys`. The logical array indicates which models in `sys` are stable.

Examples

Determine Stability of Discrete-Time Transfer Function Model

Determine the stability of this discrete-time SISO transfer function model with a sample time of 0.1 seconds.

$$\text{sys}(z) = \frac{2z}{4z^3 + 3z - 1}$$

Create the discrete-time transfer function model.

```
sys = tf([2,0],[4,0,3,-1],0.1);
```

Examine the poles of the system.

```
P = abs(pole(sys))
```

```
P = 3×1
```

```
0.9159
0.9159
0.2980
```

All the poles of the transfer function model have a magnitude less than 1, so all the poles lie within the open unit disk and the system is stable.

Confirm the stability of the model using `isstable`.

```
B = isstable(sys)
```

```
B = logical
     1
```

The system `sys` is stable.

Determine Stability of Continuous-Time Zero-Pole-Gain Model

Determine the stability of this continuous-time zero-pole-gain model.

$$\text{sys}(s) = \frac{2}{(s + 2 + 3j)(s + 2 - 3j)(s - 0.5)}$$

Create the model as a `zpk` model object by specifying the zeros, poles, and gain.

```
sys = zpk([], [-2-3*j, -2+3*j, 0.5], 2);
```

Because one pole of the model lies in the right half of the complex plane, the system is unstable.

Confirm the instability of the model using `isstable`.

```
B = isstable(sys)
```

```
B = logical
     0
```

The system `sys` is unstable.

Determine Stability of Models in Model Array

Determine the stability of an array of SISO transfer function models with poles varying from -2 to 2.

$$\left[\frac{1}{s+2}, \frac{1}{s+1}, \frac{1}{s}, \frac{1}{s-1}, \frac{1}{s-2} \right]$$

To create the array, first initialize an array of dimension `[length(a), 1]` with zero-valued SISO transfer functions.

```
a = [-2:2];
sys = tf(zeros(1,1,length(a)));
```

Populate the array with transfer functions of the form $1/(s-a)$.

```
for j = 1:length(a)
    sys(1,1,j) = tf(1,[1 -a(j)]);
end
```

`isstable` can tell you whether all the models in model array are stable or each individual model is stable.

Examine the stability of the model array.

```
B_all = isstable(sys)
```

```
B_all = logical
      0
```

By default, `isstable` returns a single logical value that is 1 (true) only if all models in the array are stable. `sys` contains some models with nonnegative poles, which are not stable. Therefore, `isstable` returns 0 (false) for the entire array.

Examine the stability of each model in the array by using 'elem' flag.

```
B_elem = isstable(sys, 'elem')
```

```
B_elem = 5x1 logical array
```

```
  1
  1
  0
  0
  0
```

The function returns an array of logical values that indicate the stability of the corresponding entry in the model array. For example, `B_elem(2)` is 1, which indicates that the second model in the array, `sys(1,1,2)` is stable. This is because `sys(1,1,2)` has a pole at -1.

Input Arguments

sys — Dynamic system

dynamic system model | model array

Dynamic system, specified as a SISO or MIMO dynamic system model or an array of SISO or MIMO dynamic system models. Dynamic systems that you can use include continuous-time or discrete-time numeric LTI models such as `tf`, `zpk`, or `ss` models.

If `sys` is a generalized state-space model `genss` or an uncertain state-space model `uss`, `isstable` checks the stability of the current or nominal value of `sys`.

If `sys` is an array of models, `isstable` checks the stability of every model in the array.

- If you use `B = isstable(sys)`, the output is 1 (true) only if all the models in the array are stable.
- If you use `B = isstable(sys, 'elem')`, the output is a logical array, the entries of which indicate the stability of the corresponding entry in the model array.

For more information on model arrays, see “Model Arrays”.

Output Arguments

B — True or false result

1 | 0 | logical array

True or false result, returned as 1 for a stable model or 0 for an unstable model.

The 'elem' flag causes `isstable` to return an array of logical values with same dimensions as the model array. The values in the array indicate the stability of the corresponding entry in the model array.

Version History

Introduced in R2012a

See Also

`isproper` | `issiso` | `pole`

issiso

Determine if dynamic system model is single-input/single-output (SISO)

Syntax

```
issiso(sys)
```

Description

`issiso(sys)` returns a logical value of 1 (`true`) if the dynamic system model `sys` is SISO and a logical value of 0 (`false`) otherwise.

Version History

Introduced before R2006a

See Also

`isempty` | `size`

isstatic

Determine if model is static or dynamic

Syntax

```
B = isstatic(sys)
B = isstatic(sys,'elem')
```

Description

`B = isstatic(sys)` returns a logical value of 1 (`true`) if the model `sys` is a static model, and a logical value of 0 (`false`) if `sys` has dynamics, such as states or delays. If `sys` is a model array, then `B = 1` if all models in `sys` are static.

`B = isstatic(sys, 'elem')` checks each model in the model array `sys` and returns a logical array of the same size as `sys`. The logical array indicates which models in `sys` are static.

Input Arguments

sys — Model or array to check
input-output model | model array

Model or array to check, specified as an input-output model or model array. Input-output models include dynamic system models such as numeric LTI models and generalized models. Input-output models also include static models such as tunable parameters or generalized matrices.

Output Arguments

B — Flag indicating whether input model is static
logical | logical array

Flag indicating whether input model is static, returned as a logical value or logical array.

Version History

Introduced in R2013a

See Also

`pole` | `zero` | `hasdelay`

Topics

“Types of Model Objects”

kalman

Design Kalman filter for state estimation

Syntax

```
[kalmf,L,P] = kalman(sys,Q,R,N)
[kalmf,L,P] = kalman(sys,Q,R,N,sensors,known)
[kalmf,L,P,Mx,Z,My] = kalman(____)
[kalmf,L,P,Mx,Z,My] = kalman(____,type)
```

Description

`[kalmf,L,P] = kalman(sys,Q,R,N)` creates a Kalman filter given the plant model `sys` and the noise covariance data `Q`, `R`, and `N`. The function computes a Kalman filter for use in a Kalman estimator with the configuration shown in the following diagram.

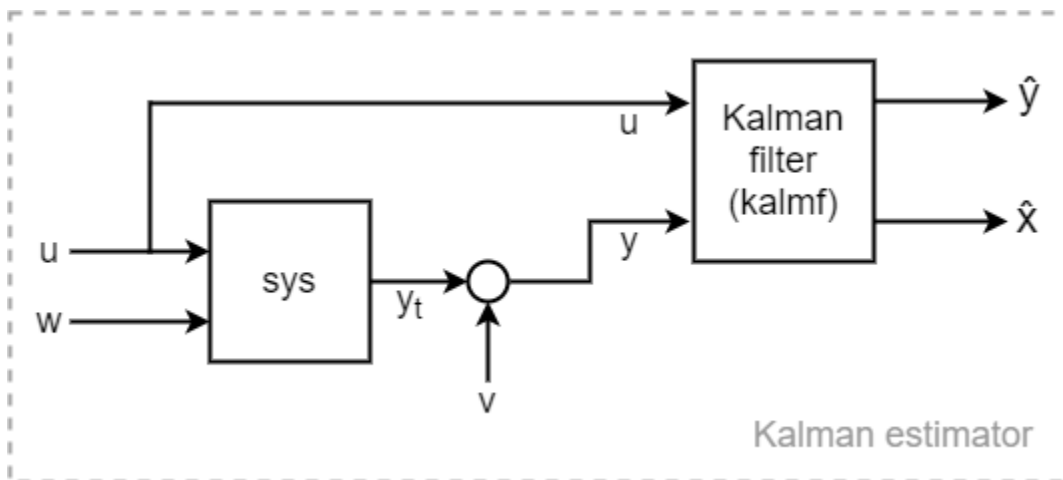

You construct the model `sys` with known inputs u and white process noise inputs w , such that w consists of the last N_w inputs to `sys`. The "true" plant output y_t consists of all outputs of `sys`. You also provide the noise covariance data `Q`, `R`, and `N`. The returned Kalman filter `kalmf` is a state-space model that takes the known inputs u and the noisy measurements y and produces an estimate \hat{y} of the true plant output and an estimate \hat{x} of the plant states. `kalman` also returns the Kalman gains `L` and the steady-state error covariance matrix `P`.

`[kalmf,L,P] = kalman(sys,Q,R,N,sensors,known)` computes a Kalman filter when one or both of the following conditions exist.

- Not all outputs of `sys` are measured.
- The disturbance inputs w are not the last inputs of `sys`.

The index vector `sensors` specifies which outputs of `sys` are measured. These outputs make up y . The index vector `known` specifies which inputs are known (deterministic). The known inputs make up u . The `kalman` command takes the remaining inputs of `sys` to be the stochastic inputs w .

`[kalmf,L,P,Mx,Z,My] = kalman(____)` also returns the innovation gains `Mx` and `My` and the steady-state error covariances `P` and `Z` for a discrete-time `sys`. You can use this syntax with any of the previous input argument combinations.

`[kalmf,L,P,Mx,Z,My] = kalman(____,type)` specifies the estimator type for a discrete-time `sys`.

- `type = 'current'` — Compute output estimates $\hat{y}[n|n]$ and state estimates $\hat{x}[n|n]$ using all available measurements up to $y[n]$.
- `type = 'delayed'` — Compute output estimates $\hat{y}[n|n-1]$ and state estimates $\hat{x}[n|n-1]$ using measurements only up to $y[n-1]$. The delayed estimator is easier to implement inside control loops.

You can use the `type` input argument with any of the previous input argument combinations.

Examples

Design Kalman Filter for SISO Plant

Design a Kalman filter for a plant that has additive white noise w on the input and v on the output, as shown in the following diagram.

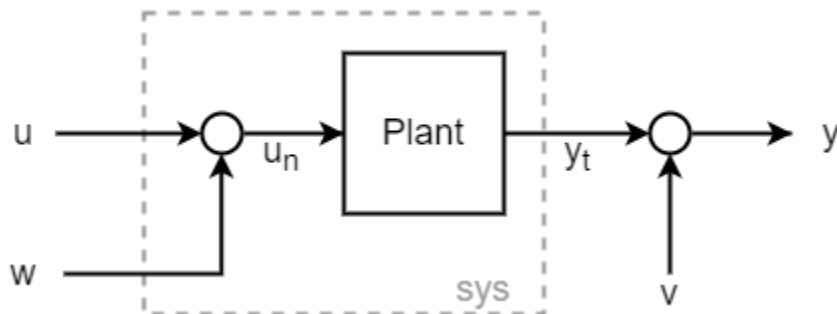

Assume that the plant has the following state-space matrices and is a discrete-time plant with an unspecified sample time ($T_s = -1$).

```
A = [1.1269  -0.4940  0.1129
      1.0000   0       0
      0       1.0000  0];
```

```
B = [-0.3832
      0.5919
      0.5191];
```

```
C = [1 0 0];
```

```
D = 0;
```

```
Plant = ss(A,B,C,D,-1);
Plant.InputName = 'un';
Plant.OutputName = 'yt';
```

To use `kalman`, you must provide a model `sys` that has an input for the noise w . Thus, `sys` is not the same as `Plant`, because `Plant` takes the input $un = u + w$. You can construct `sys` by creating a summing junction for the noise input.

```
Sum = sumblk('un = u + w');
sys = connect(Plant,Sum,{'u','w'},'yt');
```

Equivalently, you can use `sys = Plant*[1 1]`.

Specify the noise covariances. Because the plant has one noise input and one output, these values are scalar. In practice, these values are properties of the noise sources in your system, which you determine by measurement or other knowledge of your system. For this example, assume both noise sources have unit covariance and are not correlated ($N = 0$).

```
Q = 1;
R = 1;
N = 0;
```

Design the filter.

```
[kalmf,L,P] = kalman(sys,Q,R,N);
size(kalmf)
```

State-space model with 4 outputs, 2 inputs, and 3 states.

The Kalman filter `kalmf` is a state-space model having two inputs and four outputs. `kalmf` takes as inputs the plant input signal u and the noisy plant output $y = y_t + v$. The first output is the estimated true plant output \hat{y} . The remaining three outputs are the state estimates \hat{x} . Examine the input and output names of `kalmf` to see how `kalman` labels them accordingly.

`kalmf.InputName`

```
ans = 2x1 cell
    {'u' }
    {'yt'}
```

`kalmf.OutputName`

```
ans = 4x1 cell
    {'yt_e'}
    {'x1_e'}
    {'x2_e'}
    {'x3_e'}
```

Examine the Kalman gains `L`. For a SISO plant with three states, `L` is a three-element column vector.

`L`

```
L = 3x1
    0.3586
    0.3798
    0.0817
```

For an example that shows how to use `kalmf` to reduce measurement error due to noise, see “Kalman Filtering”.

Design Kalman Filter for MIMO Plant

Consider a plant with three inputs, one of which represents process noise w , and two measured outputs. The plant has four states.

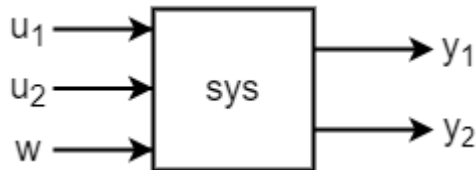

Assuming the following state-space matrices, create `sys`.

```
A = [-0.71  0.06 -0.19 -0.17;
      0.06 -0.52 -0.03  0.30;
      -0.19 -0.03 -0.24 -0.02;
      -0.17  0.30 -0.02 -0.41];
```

```
B = [ 1.44  2.91  0;
      -1.97  0.83 -0.27;
      -0.20  1.39  1.10;
      -1.2   0   -0.28];
```

```
C = [ 0   -0.36 -1.58  0.28;
      -2.05  0   0.51  0.03];
```

```
D = zeros(2,3);
```

```
sys = ss(A,B,C,D);
sys.InputName = {'u1','u2','w'};
sys.OutputName = {'y1','y2'};
```

Because the plant has only one process noise input, the covariance Q is a scalar. For this example, assume the process noise has unit covariance.

```
Q = 1;
```

`kalman` uses the dimensions of Q to determine which inputs are known and which are the noise inputs. For scalar Q , `kalman` assumes one noise input and uses the last input, unless you specify otherwise (see “Plant with Unmeasured Outputs” on page 2-602).

For the measurement noise on the two outputs, specify a 2-by-2 noise covariance matrix. For this example, use a unit variance for the first output, and variance of 1.3 for the second output. Set the off-diagonal values to zero to indicate that the two noise channels are uncorrelated.

```
R = [1 0;
      0 1.3];
```

Design the Kalman filter.

```
[kalmf,L,P] = kalman(sys,Q,R);
```

Examine the inputs and outputs. `kalman` uses the `InputName`, `OutputName`, `InputGroup`, and `OutputGroup` properties of `kalmf` to help you keep track of what the inputs and outputs of `kalmf` represent.

`kalmf.InputGroup`

```
ans = struct with fields:
    KnownInput: [1 2]
    Measurement: [3 4]
```

`kalmf.InputName`

```
ans = 4x1 cell
    {'u1'}
    {'u2'}
    {'y1'}
    {'y2'}
```

`kalmf.OutputGroup`

```
ans = struct with fields:
    OutputEstimate: [1 2]
    StateEstimate: [3 4 5 6]
```

`kalmf.OutputName`

```
ans = 6x1 cell
    {'y1_e'}
    {'y2_e'}
    {'x1_e'}
    {'x2_e'}
    {'x3_e'}
    {'x4_e'}
```

Thus the two known inputs `u1` and `u2` are the first two inputs of `kalmf` and the two measured outputs `y1` and `y2` are the last two inputs to `kalmf`. For the outputs of `kalmf`, the first two are the estimated outputs, and the remaining four are the state estimates. To use the Kalman filter, connect these inputs to the plant and noise signals in a manner analogous to that shown for a SISO plant in “Kalman Filtering”.

Plant with Unmeasured Outputs

Consider a plant with four inputs and two outputs. The first and third inputs are known, while the second and fourth inputs represent the process noise. The plant also has two outputs, but only the second of them is measured.

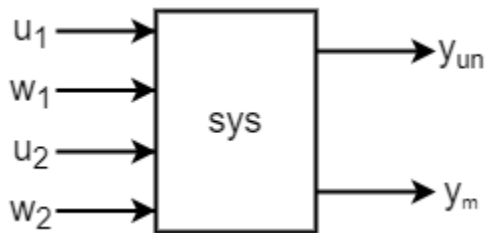

Use the following state-space matrices to create `sys`.

```
A = [-0.37  0.14 -0.01  0.04;
      0.14 -1.89  0.98 -0.11;
      -0.01  0.98 -0.96 -0.14;
      0.04 -0.11 -0.14 -0.95];
```

```
B = [-0.07 -2.32  0.68  0.10;
      -2.49  0.08  0      0.83;
      0     -0.95  0      0.54;
      -2.19  0.41  0.45  0.90];
```

```
C = [ 0     0    -0.50 -0.38;
      -0.15 -2.12 -1.27  0.65];
```

```
D = zeros(2,4);
```

```
sys = ss(A,B,C,D,-1);    % Discrete with unspecified sample time
```

```
sys.InputName = {'u1', 'w1', 'u2', 'w2'};
sys.OutputName = {'yun', 'ym'};
```

To use `kalman` to design a filter for this system, use the `known` and `sensors` input arguments to specify which inputs to the plant are known and which output is measured.

```
known = [1 3];
sensors = [2];
```

Specify the noise covariances and design the filter.

```
Q = eye(2);
R = 1;
N = 0;
```

```
[kalmf,L,P] = kalman(sys,Q,R,N,sensors,known);
```

Examining the input and output labels of `kalmf` shows the inputs that the filter expects and the outputs it returns.

```
kalmf.InputGroup
```

```
ans = struct with fields:
    KnownInput: [1 2]
    Measurement: 3
```

```
kalmf.InputName
```

```
ans = 3x1 cell
    {'u1'}
```

```
{'u2'}
{'ym'}
```

`kalmf` takes as inputs the two known inputs of `sys` and the noisy measured outputs of `sys`.

`kalmf.OutputGroup`

```
ans = struct with fields:
  OutputEstimate: 1
  StateEstimate: [2 3 4 5]
```

The first output of `kalmf` is its estimate of the true value of the measured plant output. The remaining outputs are the state estimates.

Input Arguments

`sys` — Plant model with process noise

ss model

Plant model with process noise, specified as a state-space (ss) model. The plant has known inputs u and white process noise inputs w . The plant output y_t does not include the measurement noise.

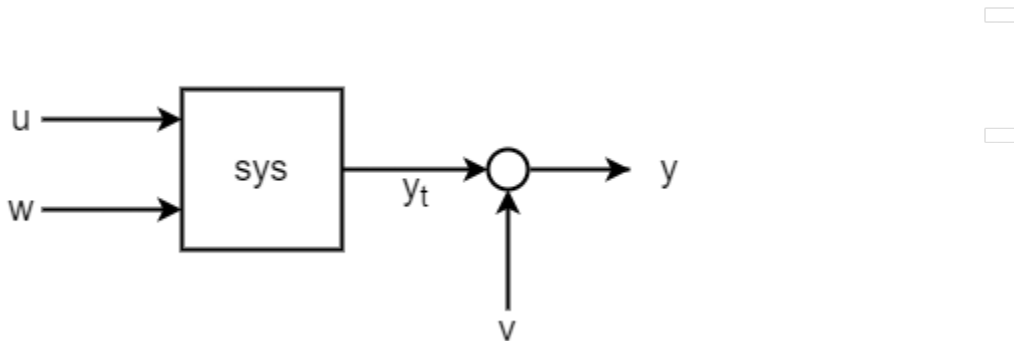

You can write the state-space matrices of such a plant model as:

$A, [B\ G], C, [D\ H]$

`kalman` assumes the Gaussian noise v on the output. Thus, in continuous time, the state-space equations that `kalman` works with are:

$$\begin{aligned}\dot{x} &= Ax + Bu + Gw \\ y &= Cx + Du + Hw + v\end{aligned}$$

In discrete time, the state-space equations are:

$$\begin{aligned}x[n + 1] &= Ax[n] + Bu[n] + Gw[n] \\ y[n] &= Cx[n] + Du[n] + Hw[n] + v[n]\end{aligned}$$

If you do not use the known input argument, `kalman` uses the size of `Q` to determine which inputs of `sys` are noise inputs. In this case, `kalman` treats the last $N_w = \text{size}(Q, 1)$ inputs as the noise inputs.

When the noise inputs w are not the last inputs of `sys`, you can use the `known` input argument to specify which plant inputs are known. `kalman` treats the remaining inputs as stochastic.

For additional constraints on the properties of the plant matrices, see “Limitations” on page 2-607.

Q — Process noise covariance

scalar | matrix

Process noise covariance, specified as a scalar or N_w -by- N_w matrix, where N_w is the number of noise inputs to the plant. `kalman` uses the size of Q to determine which inputs of `sys` are noise inputs, taking the last $N_w = \text{size}(Q, 1)$ inputs to be the noise inputs unless you specify otherwise with the `known` input argument.

`kalman` assumes that the process noise w is Gaussian noise with covariance $Q = E(w w^T)$. When the plant has only one process noise input, Q is a scalar equal to the variance of w . When the plant has multiple, uncorrelated noise inputs, Q is a diagonal matrix. In practice, you determine the appropriate values for Q by measuring or making educated guesses about the noise properties of your system.

R — Measurement noise covariance

scalar | matrix

Measurement noise covariance, specified as a scalar or N_y -by- N_y matrix, where N_y is the number of plant outputs. `kalman` assumes that the measurement noise v is white noise with covariance $R = E(v v^T)$. When the plant has only one output channel, R is a scalar equal to the variance of v . When the plant has multiple output channels with uncorrelated measurement noise, R is a diagonal matrix. In practice, you determine the appropriate values for R by measuring or making educated guesses about the noise properties of your system.

For additional constraints on the measurement noise covariance, see “Limitations” on page 2-607.

N — Noise cross covariance

0 (default) | scalar | matrix

Noise cross covariance, specified as a scalar or N_y -by- N_w matrix. `kalman` assumes that the process noise w and the measurement noise v satisfy $N = E(w v^T)$. If the two noise sources are not correlated, you can omit N , which is equivalent to setting $N = \mathbf{0}$. In practice, you determine the appropriate values for N by measuring or making educated guesses about the noise properties of your system.

sensors — Measured outputs of sys

vector

Measured outputs of `sys`, specified as a vector of indices identifying which outputs of `sys` are measured. For instance, suppose that your system has three outputs, but only two of them are measured, corresponding to the first and third outputs of `sys`. In this case, set `sensors = [1 3]`.

known — Known inputs of sys

vector

Known inputs of `sys`, specified as a vector of indices identifying which inputs are known (deterministic). For instance, suppose that your system has three inputs, but only the first and second inputs are known. In this case, set `known = [1 2]`. `kalman` interprets any remaining inputs of `sys` to be stochastic.

type — Type of discrete-time estimator

'current' (default) | 'delayed'

Type of discrete-time estimator to compute, specified as either 'current' or 'delayed'. This input is relevant only for discrete-time `sys`.

- 'current' — Compute output estimates $\hat{y}[n|n]$ and state estimates $\hat{x}[n|n]$ using all available measurements up to $y[n]$.
- 'delayed' — Compute output estimates $\hat{y}[n|n-1]$ and state estimates $\hat{x}[n|n-1]$ using measurements only up to $y[n-1]$. The delayed estimator is easier to implement inside control loops.

For details about how `kalman` computes the current and delayed estimates, see “Discrete-Time Estimation” on page 2-608.

Output Arguments

`kalmf` — Kalman estimator

ss model

Kalman estimator or kalman filter, returned as a state-space (ss) model. The resulting estimator has inputs $[u; y]$ and outputs $[\hat{y}; \hat{x}]$. In other words, `kalmf` takes as inputs the plant input u and the noisy plant output y , and produces as outputs the estimated noise-free plant output \hat{y} and the estimated state values \hat{x} .

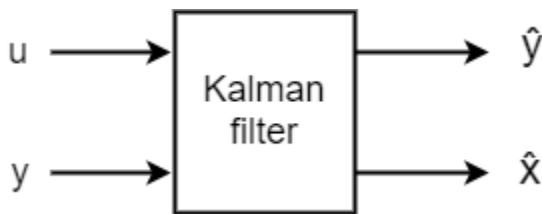

`kalman` automatically sets the `InputName`, `OutputName`, `InputGroup`, and `OutputGroup` properties of `kalmf` to help you keep track of which inputs and outputs correspond to which signals.

For the state and output equations of `kalmf`, see “Continuous-Time Estimation” on page 2-608 and “Discrete-Time Estimation” on page 2-608.

L — Filter gains

array

Filter gains, returned as an array of size N_x -by- N_y , where N_x is the number of states in the plant and N_y is the number of plant outputs. In continuous time, the state equation of the Kalman filter is:

$$\dot{\hat{x}} = A\hat{x} + Bu + L(y - C\hat{x} - Du).$$

In discrete time, the state equation is:

$$\hat{x}[n+1|n] = A\hat{x}[n|n-1] + Bu[n] + L(y[n] - C\hat{x}[n|n-1] - Du[n]).$$

For details about these expressions and how `L` is computed, see “Continuous-Time Estimation” on page 2-608 and “Discrete-Time Estimation” on page 2-608.

P, Z — Steady-state error covariances

array

Steady-state error covariances, returned as N_x -by- N_x , where N_x is the number of states in the plant. The Kalman filter computes state estimates that minimize P . In continuous time, the steady-state error covariance is given by:

$$P = \lim_{t \rightarrow \infty} E\left(\{x - \hat{x}\}\{x - \hat{x}\}^T\right).$$

In discrete time, the steady-state error covariances are given by:

$$P = \lim_{n \rightarrow \infty} E\left(\{x[n] - \hat{x}[n|n-1]\}\{x[n] - \hat{x}[n|n-1]\}^T\right),$$

$$Z = \lim_{n \rightarrow \infty} E\left(\{x[n] - \hat{x}[n|n]\}\{x[n] - \hat{x}[n|n]\}^T\right).$$

For further details about these quantities and how `kalman` uses them, see “Continuous-Time Estimation” on page 2-608 and “Discrete-Time Estimation” on page 2-608.

Mx, My — Innovation gains of state estimators

array

Innovation gains of the state estimators for discrete-time systems, returned as an array.

M_x and M_y are relevant only when `type = 'current'`, which is the default estimator for discrete-time systems. For continuous-time `sys` or `type = 'delayed'`, then $M_x = M_y = []$.

For the 'current' type estimator, M_x and M_y are the innovation gains in the update equations:

$$\hat{x}[n|n] = \hat{x}[n|n-1] + M_x(y[n] - C\hat{x}[n|n-1] - Du[n])$$

$$\hat{y}[n|n] = C\hat{x}[n|n-1] + Du[n] + M_y(y[n] - C\hat{x}[n|n-1] - Du[n])$$

When there is no direct feedthrough from the noise input w to the plant output y (that is, when $H = 0$, see “Discrete-Time Estimation” on page 2-608), then $M_y = CM_x$, and the output estimate simplifies to $\hat{y}[n|n] = C\hat{x}[n|n] + Du[n]$.

The dimensions of the arrays M_x and M_y depend on the dimensions of `sys` as follows.

- M_x — N_x -by- N_x , where N_x is the number of states in the plant and N_y is the number of outputs.
- M_y — N_y -by- N_y .

For details about how `kalman` obtains M_x and M_y , see “Discrete-Time Estimation” on page 2-608.

Limitations

The plant and noise data must satisfy:

- (C,A) is detectable, where:
- $\bar{R} > 0$ and $\begin{bmatrix} \bar{Q} & \bar{N} \\ \bar{N}' & \bar{R} \end{bmatrix} \geq 0$, where

$$\begin{bmatrix} \bar{Q} & \bar{N} \\ \bar{N}' & \bar{R} \end{bmatrix} = \begin{bmatrix} G & 0 \\ H & I \end{bmatrix} \begin{bmatrix} Q & N \\ N' & R \end{bmatrix} \begin{bmatrix} G & 0 \\ H & I \end{bmatrix}.$$

- $(A - \bar{N}\bar{R}^{-1}C, \bar{Q} - \bar{N}\bar{R}^{-1}\bar{N}^T)$ has no uncontrollable mode on the imaginary axis in continuous time, or on the unit circle in discrete time.

Algorithms

Continuous-Time Estimation

Consider a continuous-time plant with known inputs u , white process noise w , and white measurement noise v :

$$\begin{aligned}\dot{x} &= Ax + Bu + Gw \\ y &= Cx + Du + Hw + v\end{aligned}$$

The noise signals w and v satisfy:

$$E(w) = E(v) = 0, \quad E(ww^T) = Q, \quad E(vv^T) = R, \quad E(wv^T) = N$$

The Kalman filter, or Kalman estimator, computes a state estimate $\hat{x}(t)$ that minimizes the steady-state error covariance:

$$P = \lim_{t \rightarrow \infty} E(\{x - \hat{x}\}\{x - \hat{x}\}^T).$$

The Kalman filter has the following state and output equations:

$$\begin{aligned}\frac{d\hat{x}}{dt} &= A\hat{x} + Bu + L(y - C\hat{x} - Du) \\ \begin{bmatrix} \hat{y} \\ \hat{x} \end{bmatrix} &= \begin{bmatrix} C \\ I \end{bmatrix} \hat{x} + \begin{bmatrix} D \\ 0 \end{bmatrix} u\end{aligned}$$

To obtain the filter gain L , kalman solves an algebraic Riccati equation to obtain

$$L = (PC^T + \bar{N})\bar{R}^{-1}$$

where

$$\begin{aligned}\bar{R} &= R + HN + N^T H^T + HQH^T \\ \bar{N} &= G(QH^T + N)\end{aligned}$$

P solves the corresponding algebraic Riccati equation.

The estimator uses the known inputs u and the measurements y to generate the output and state estimates \hat{y} and \hat{x} .

Discrete-Time Estimation

The discrete plant is given by:

$$\begin{aligned}x[n+1] &= Ax[n] + Bu[n] + Gw[n] \\ y[n] &= Cx[n] + Du[n] + Hw[n] + v[n]\end{aligned}$$

In discrete time, the noise signals w and v satisfy:

$$E(w[n]w[n]^T) = Q, \quad E(v[n]v[n]^T) = R, \quad E(w[n]v[n]^T) = N$$

The discrete-time estimator has the following state equation:

$$\hat{x}[n+1|n] = A\hat{x}[n|n-1] + Bu[n] + L(y[n] - C\hat{x}[n|n-1] - Du[n]).$$

kalman solves a discrete Riccati equation to obtain the gain matrix L :

$$L = (APC^T + \bar{N})(CPC^T + \bar{R})^{-1}$$

where

$$\bar{R} = R + HN + N^T H^T + HQH^T$$

$$\bar{N} = G(QH^T + N)$$

kalman can compute two variants of the discrete-time Kalman estimator, the current estimator (`type = 'current'`) and the delayed estimator (`type = 'delayed'`).

- Current estimator — Generates output estimates $\hat{y}[n|n]$ and state estimates $\hat{x}[n|n]$ using all available measurements up to $y[n]$. This estimator has the output equation

$$\begin{bmatrix} \hat{y}[n|n] \\ \hat{x}[n|n] \end{bmatrix} = \begin{bmatrix} (I - M_y)C \\ I - M_x C \end{bmatrix} \hat{x}[n|n-1] + \begin{bmatrix} (I - M_y)D & M_y \\ -M_x D & M_x \end{bmatrix} \begin{bmatrix} u[n] \\ y[n] \end{bmatrix}.$$

where the innovation gains M_x and M_y are defined as:

$$M_x = PC^T(CPC^T + \bar{R})^{-1},$$

$$M_y = (CPC^T + HQH^T + HN)(CPC^T + \bar{R})^{-1}.$$

Thus, M_x updates the state estimate $\hat{x}[n|n-1]$ using the new measurement $y[n]$:

$$\hat{x}[n|n] = \hat{x}[n|n-1] + M_x(y[n] - C\hat{x}[n|n-1] - Du[n])$$

Similarly, M_y computes the updated output estimate:

$$\hat{y}[n|n] = C\hat{x}[n|n-1] + Du[n] + M_y(y[n] - C\hat{x}[n|n-1] - Du[n])$$

When $H = 0$, then $M_y = CM_x$, and the output estimate simplifies to $\hat{y}[n|n] = C\hat{x}[n|n] + Du[n]$.

- Delayed estimator — Generates output estimates $\hat{y}[n|n-1]$ and state estimates $\hat{x}[n|n-1]$ using measurements only up to $y[n-1]$. This estimator has the output equation:

$$\begin{bmatrix} \hat{y}[n|n-1] \\ \hat{x}[n|n-1] \end{bmatrix} = \begin{bmatrix} C \\ I \end{bmatrix} \hat{x}[n|n-1] + \begin{bmatrix} D & 0 \\ 0 & 0 \end{bmatrix} \begin{bmatrix} u[n] \\ y[n] \end{bmatrix}$$

The delayed estimator is easier to deploy inside control loops.

Version History

Introduced before R2006a

See Also

Blocks

Kalman Filter

Topics

Kalman Filtering

“LQG Design for the x-Axis”

kalmd

Design discrete Kalman estimator for continuous plant

Syntax

`[kest,L,P,M,Z] = kalmd(sys,Qn,Rn,Ts)`

Description

`kalmd` designs a discrete-time Kalman estimator that has response characteristics similar to a continuous-time estimator designed with `kalman`. This command is useful to derive a discrete estimator for digital implementation after a satisfactory continuous estimator has been designed.

`[kest,L,P,M,Z] = kalmd(sys,Qn,Rn,Ts)` produces a discrete Kalman estimator `kest` with sample time `Ts` for the continuous-time plant

$$\begin{aligned}\dot{x} &= Ax + Bu + Gw && \text{(state equation)} \\ y_v &= Cx + Du + v && \text{(measurement equation)}\end{aligned}$$

with process noise w and measurement noise v satisfying

$$E(w) = E(v) = 0, \quad E(ww^T) = Q_n, \quad E(vv^T) = R_n, \quad E(wv^T) = 0$$

The estimator `kest` is derived as follows. The continuous plant `sys` is first discretized using zero-order hold with sample time `Ts` (see `c2d` entry), and the continuous noise covariance matrices Q_n and R_n are replaced by their discrete equivalents

$$\begin{aligned}Q_d &= \int_0^{T_s} e^{A\tau} G Q_n G^T e^{A^T \tau} d\tau \\ R_d &= R_n / T_s\end{aligned}$$

The integral is computed using the matrix exponential formulas in [2]. A discrete-time estimator is then designed for the discretized plant and noise. See `kalman` for details on discrete-time Kalman estimation.

`kalmd` also returns the estimator gains L and M , and the discrete error covariance matrices P and Z (see `kalman` for details).

Limitations

The discretized problem data should satisfy the requirements for `kalman`.

Version History

Introduced before R2006a

References

- [1] Franklin, G.F., J.D. Powell, and M.L. Workman, *Digital Control of Dynamic Systems*, Second Edition, Addison-Wesley, 1990.
- [2] Van Loan, C.F., "Computing Integrals Involving the Matrix Exponential," *IEEE Trans. Automatic Control*, AC-15, October 1970.

See Also

kalman | lqgreg | lqrd

lft

Generalized feedback interconnection of two models (Redheffer star product)

Syntax

```
lft
sys = lft(sys1,sys2,nu,ny)
```

Description

`lft` forms the star product or linear fractional transformation (LFT) of two model objects or model arrays. Such interconnections are widely used in robust control techniques.

`sys = lft(sys1,sys2,nu,ny)` forms the star product `sys` of the two models (or arrays) `sys1` and `sys2`. The star product amounts to the following feedback connection for single models (or for each model in an array).

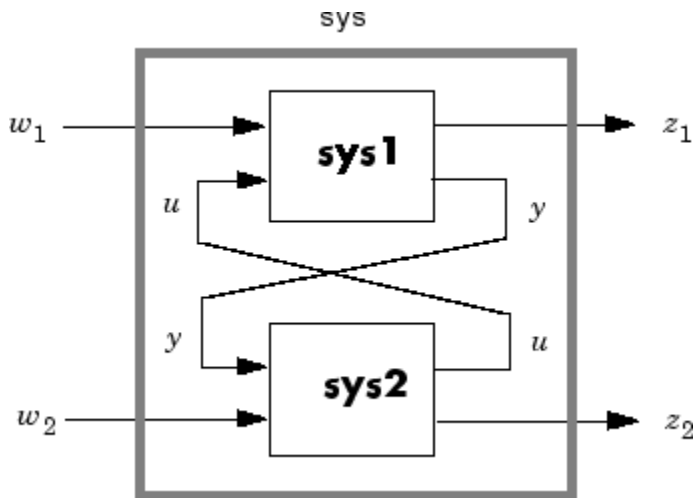

This feedback loop connects the first nu outputs of `sys2` to the last nu inputs of `sys1` (signals u), and the last ny outputs of `sys1` to the first ny inputs of `sys2` (signals y). The resulting system `sys` maps the input vector $[w_1 ; w_2]$ to the output vector $[z_1 ; z_2]$.

The abbreviated syntax

```
sys = lft(sys1,sys2)
```

produces:

- The lower LFT of `sys1` and `sys2` if `sys2` has fewer inputs and outputs than `sys1`. This amounts to deleting w_2 and z_2 in the above diagram.
- The upper LFT of `sys1` and `sys2` if `sys1` has fewer inputs and outputs than `sys2`. This amounts to deleting w_1 and z_1 in the above diagram.

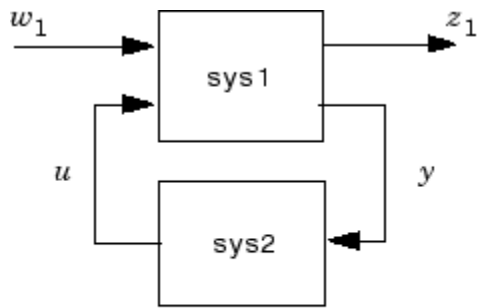

Lower LFT connection

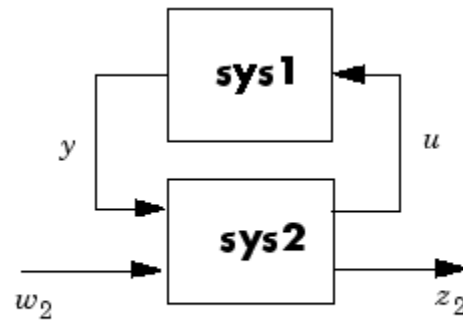

Upper LFT connection

Limitations

There should be no algebraic loop in the feedback connection.

Algorithms

The closed-loop model is derived by elementary state-space manipulations.

Version History

Introduced before R2006a

See Also

connect | feedback

Linear System Analyzer

Analyze time and frequency responses of linear time-invariant (LTI) systems

Description

The **Linear System Analyzer** app lets you analyze time and frequency responses of LTI systems. Using this app, you can:

- View and compare the response plots of SISO and MIMO systems, or of several linear models at the same time.
- Generate time response plots such as step, impulse, and time response to arbitrary inputs.
- Generate frequency response plots such as Bode, Nyquist, Nichols, singular-value, and pole-zero plots.
- Inspect key response characteristics, such as rise time, maximum overshoot, and stability margins.

Available Plots

Linear System Analyzer can generate the following response plots:

- Step response
- Impulse response
- Simulated time response to specified input signal
- Simulated time response from specified initial conditions (state-space models only)
- Bode diagram (magnitude and phase, or magnitude alone)
- Nyquist plot
- Nichols plot
- Singular value plot
- Pole/zero map and I/O pole/zero map

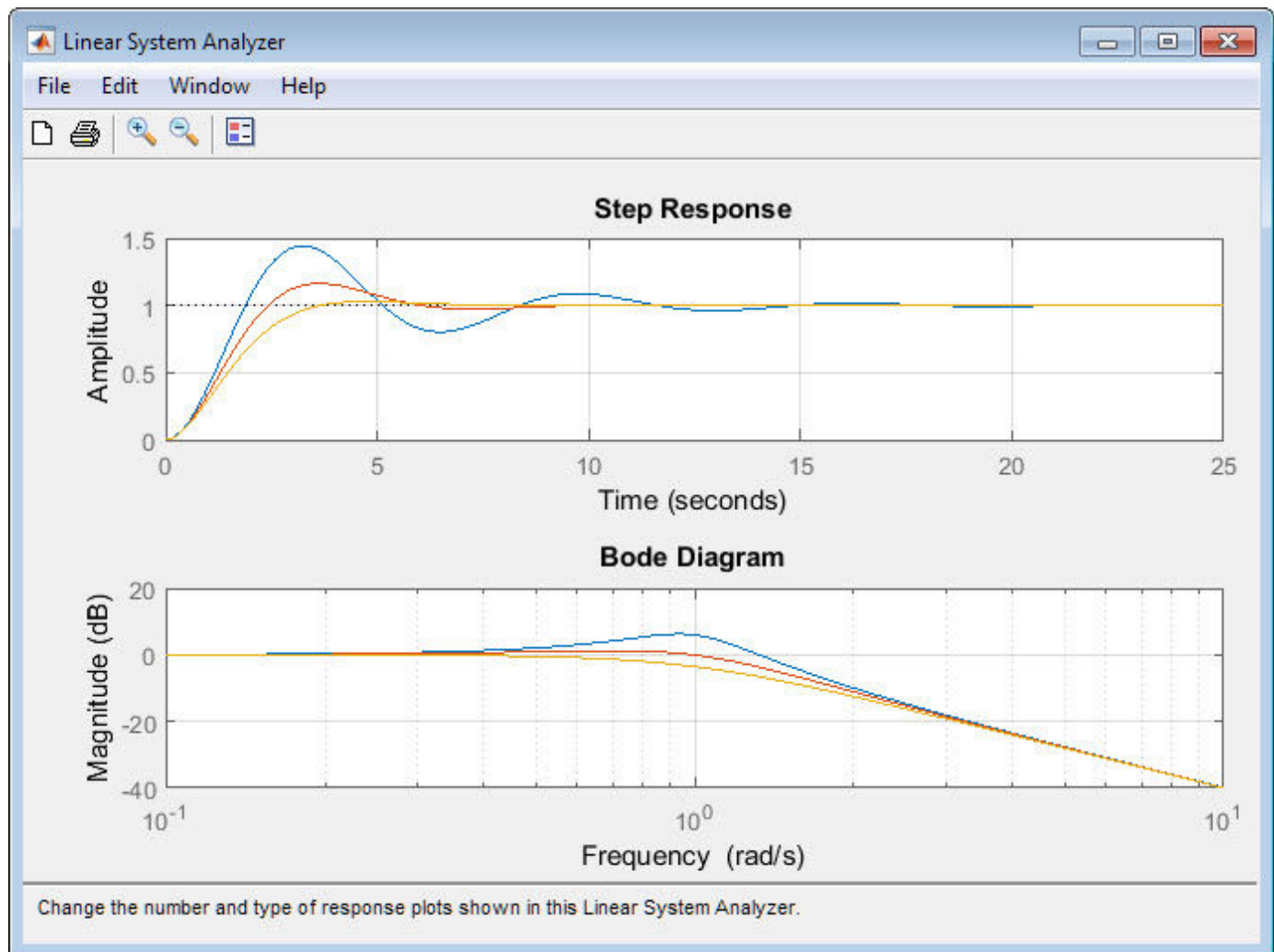

Open the Linear System Analyzer App

- MATLAB Toolstrip: On the **Apps** tab, under **Control System Design and Analysis**, click the app icon.
- MATLAB command prompt: Enter `linearSystemAnalyzer`.

Examples

- "Linear Analysis Using the Linear System Analyzer"
- "Joint Time-Domain and Frequency-Domain Analysis"

Programmatic Use

`linearSystemAnalyzer` opens the **Linear System Analyzer** app with no LTI systems to analyze. To specify a system to analyze, select **File > Import**.

`linearSystemAnalyzer(sys1,sys2,...,sysn)` opens **Linear System Analyzer** and displays the step response of one or more dynamic system models, `sys1`, `sys2`, ..., `sysn`. Such models include:

- Numeric LTI models such as `tf`, `zpk`, or `ss` models.
- Identified models such as `idtf`, `idss`, or `idproc` (requires System Identification Toolbox software).
- Generalized LTI models such as `genss` or `uss` models. For generalized LTI models without uncertainty, **Linear System Analyzer** plots the response of the nominal value of the model. For generalized models with uncertainty, the app plots the responses of 20 random samples of the uncertain system. (Uncertain models require Robust Control Toolbox software.)

`linearSystemAnalyzer(sys1,LineStyle1,sys2,LineStyle2,...,sysn,LineStylen)` specifies the line style, marker, and color of each response plot. Specify plot styles using one, two, or three characters. For example, the following code uses red asterisks for the response of `sys1`, and a magenta dotted line for the response of `sys2`.

```
linearSystemAnalyzer(sys1,'r-*',sys2,'m--');
```

For more information about configuring this argument, see the `LineStyle` input argument of the `plot` function.

`linearSystemAnalyzer(plottype, ___)` opens **Linear System Analyzer** and displays the response types specified by `plottype`. You can use this syntax with any of the previous input argument combinations. The `plottype` argument can be any one of the following:

- `'step'` — Step response.
- `'impulse'` — Impulse response.
- `'lsim'` — Linear simulation plot. When you use this plot type, the Linear Simulation Tool dialog box prompts you to specify an input signal for the simulation.
- `'initial'` — Initial condition plot (state-space models only). You can use the `extras` argument to specify the initial state. If you do not, the Linear Simulation Tool dialog box opens and prompts you to specify an initial state for the simulation.
- `'bode'` — Bode diagram.
- `'bodemag'` — Bode magnitude diagram.
- `'nyquist'` — Nyquist plot.
- `'nichols'` — Nichols plot.
- `'sigma'` — Singular value plot. (See `sigma`).
- `'pzmap'` — Pole/zero map.
- `'iopzmap'` — Pole/zero map of each input/output pair of the LTI system.

To open **Linear System Analyzer** with multiple response plots, use a cell array of up to six of these plot types for the `plottype` input argument. For example, the following command opens the app with a step response plot and a Nyquist plot for the system `sys`.

```
linearSystemAnalyzer({'step';'nyquist'},sys)
```

`linearSystemAnalyzer(plottype,sys1,sys2,...,sysn,extras)` specifies additional input arguments specific to the type of response plot. `extras` can be one or more of the input arguments available for the function corresponding to the plot type except the `plotoptions` and `dataoptions`

arguments. For example, suppose `plottype` is `'step'`. Then, `extras` enables you to use the additional arguments that you could use with the `step` command, such as the desired final time, `Tfinal`. Thus, the following command opens the app with a step response plot of `sys`, with a final time of `Tfinal`.

```
linearSystemAnalyzer('step',sys,Tfinal)
```

If `plottype` is `'initial'`, you can use `extras` to supply the initial conditions `x0`, and other arguments such as `Tfinal`. For example:

```
linearSystemAnalyzer('initial',sys,x0,Tfinal)
```

To determine appropriate arguments for `extras`, see the reference pages of the functions corresponding to each plot type, such as `step`, `bode`, or `initial`.

`h = linearSystemAnalyzer(___)` returns a handle to the **Linear System Analyzer** figure. You can use this syntax with any of the previous combinations of input arguments. Use the handle to modify previously opened **Linear System Analyzer** instances, as described in the next two syntaxes.

`linearSystemAnalyzer('clear',h)` clears the plots and data from the **Linear System Analyzer** corresponding to handle `h`. To clear multiple app instances at once, set `h` to a vector of handles.

`linearSystemAnalyzer('current',sys1,sys2,...,sysn,h)` adds the responses of the systems `sys1`, `sys2`, ..., `sysn` to the **Linear System Analyzer** corresponding to handle `h`. To update multiple app instances at once, set `h` to a vector of handles. If the new systems have different I/O dimensions from the currently displayed systems, the app clears the existing responses and displays only the new ones.

Version History

Introduced in R2015a

See Also

Apps

Control System Designer

Functions

`step` | `impulse` | `lsim` | `initial` | `iopzmap` | `pzmap` | `bode` | `bodemag` | `nyquist` | `nichols` | `sigma`

Topics

“Linear Analysis Using the Linear System Analyzer”

“Joint Time-Domain and Frequency-Domain Analysis”

lqg

Linear-Quadratic-Gaussian (LQG) design

Syntax

```
reg = lqg(sys, QXU, QWV)
reg = lqg(sys, QXU, QWV, QI)
reg = lqg(sys, QXU, QWV, QI, '1dof')
reg = lqg(sys, QXU, QWV, QI, '2dof')
reg = lqg(____, 'current')
[reg, info] = lqg(____)
```

Description

`reg = lqg(sys, QXU, QWV)` computes an optimal linear-quadratic-Gaussian (LQG) regulator `reg` given a state-space model `sys` of the plant and weighting matrices `QXU` and `QWV`. The dynamic regulator `reg` uses the measurements `y` to generate a control signal `u` that regulates `y` around the zero value. Use positive feedback to connect this regulator to the plant output `y`.

The LQG regulator minimizes the cost function

$$J = E \left\{ \lim_{\tau \rightarrow \infty} \frac{1}{\tau} \int_0^{\tau} [x^T, u^T] Q_{xu} \begin{bmatrix} x \\ u \end{bmatrix} dt \right\}$$

subject to the plant equations

$$\begin{aligned} dx/dt &= Ax + Bu + w \\ y &= Cx + Du + v \end{aligned}$$

where the process noise `w` and measurement noise `v` are Gaussian white noises with covariance:

$$E \left(\begin{bmatrix} w \\ v \end{bmatrix} \cdot [w' \ v'] \right) = QWV$$

`reg = lqg(sys, QXU, QWV, QI)` uses the setpoint command `r` and measurements `y` to generate the control signal `u`. `reg` has integral action to ensure that `y` tracks the command `r`.

The LQG servo-controller minimizes the cost function

$$J = E \left\{ \lim_{\tau \rightarrow \infty} \frac{1}{\tau} \int_0^{\tau} \left([x^T, u^T] Q_{xu} \begin{bmatrix} x \\ u \end{bmatrix} + x_i^T Q_i x_i \right) dt \right\}$$

where x_i is the integral of the tracking error $r - y$. For MIMO systems, r , y , and x_i must have the same length.

`reg = lqg(sys, QXU, QWV, QI, '1dof')` computes a one-degree-of-freedom servo controller that takes $e = r - y$ rather than $[r; y]$ as input.

`reg = lqg(sys, QXU, QWV, QI, '2dof')` is equivalent to `LQG(sys, QXU, QWV, QI)` and produces the two-degree-of-freedom servo-controller shown previously.

`reg = lqg(____, 'current')` uses the "current" Kalman estimator, which uses $x[n|n]$ as the state estimate when computing an LQG regulator for a discrete-time system.

`[reg, info] = lqg(____)` returns the controller and estimator gain matrices in the structure `info` for any of the previous syntaxes. You can use the controller and estimator gains to, for example, implement the controller in observer form. For more information, see "Algorithms" on page 2-623.

Examples

Linear-Quadratic-Gaussian (LQG) Regulator and Servo Controller Design

This example shows how to design an linear-quadratic-Gaussian (LQG) regulator, a one-degree-of-freedom LQG servo controller, and a two-degree-of-freedom LQG servo controller for the following system.

The plant has three states (x), two control inputs (u), three random inputs (w), one output (y), measurement noise for the output (v), and the following state and measurement equations.

$$\frac{dx}{dt} = Ax + Bu + w$$

$$y = Cx + Du + v$$

where

$$A = \begin{bmatrix} 0 & 1 & 0 \\ 0 & 0 & 1 \\ 1 & 0 & 0 \end{bmatrix} \quad B = \begin{bmatrix} 0.3 & 1 \\ 0 & 1 \\ -0.3 & 0.9 \end{bmatrix}$$

$$C = [1.9 \ 1.3 \ 1] \quad D = [0.53 \ -0.61]$$

The system has the following noise covariance data:

$$Q_n = E(w w^T) = \begin{bmatrix} 4 & 2 & 0 \\ 2 & 1 & 0 \\ 0 & 0 & 1 \end{bmatrix}$$

$$R_n = E(v v^T) = 0.7$$

For the regulator, use the following cost function to define the tradeoff between regulation performance and control effort:

$$J(u) = \int_0^{\infty} \left(0.1 x^T x + u^T \begin{bmatrix} 1 & 0 \\ 0 & 2 \end{bmatrix} u \right) dt$$

For the servo controllers, use the following cost function to define the tradeoff between tracker performance and control effort:

$$J(u) = \int_0^{\infty} \left(0.1 x^T x + x_i^2 + u^T \begin{bmatrix} 1 & 0 \\ 0 & 2 \end{bmatrix} u \right) dt$$

To design the LQG controllers for this system:

- 1 Create the state-space system by typing the following in the MATLAB Command Window:

```
A = [0 1 0;0 0 1;1 0 0];
B = [0.3 1;0 1;-0.3 0.9];
C = [1.9 1.3 1];
D = [0.53 -0.61];
sys = ss(A,B,C,D);
```

- 2 Define the noise covariance data and the weighting matrices by typing the following commands:

```
nx = 3;    %Number of states
ny = 1;    %Number of outputs
Qn = [4 2 0; 2 1 0; 0 0 1];
Rn = 0.7;
R = [1 0;0 2]
QXU = blkdiag(0.1*eye(nx),R);
QWV = blkdiag(Qn,Rn);
QI = eye(ny);
```

- 3 Form the LQG regulator by typing the following command:

```
KLQG = lqg(sys,QXU,QWV)
```

This command returns the following LQG regulator:

```
A =
      x1_e   x2_e   x3_e
x1_e  -6.212  -3.814  -4.136
x2_e  -4.038  -3.196  -1.791
x3_e  -1.418  -1.973  -1.766

B =
      y1
x1_e   2.365
x2_e   1.432
x3_e   0.7684

C =
      x1_e   x2_e   x3_e
u1  -0.02904  0.0008272  0.0303
u2   -0.7147  -0.7115  -0.7132

D =
      y1
u1    0
u2    0

Input groups:
      Name      Channels
Measurement    1

Output groups:
      Name      Channels
Controls       1,2
```

Continuous-time model.

- 4 Form the one-degree-of-freedom LQG servo controller by typing the following command:

```
KLQG1 = lqg(sys,QXU,QWV,QI,'1dof')
```

This command returns the following LQG servo controller:

```
A =
      x1_e   x2_e   x3_e   xil
x1_e -7.626 -5.068 -4.891 0.9018
x2_e -5.108 -4.146 -2.362 0.6762
x3_e -2.121 -2.604 -2.141 0.4088
xil   0       0       0       0
```

```
B =
      e1
x1_e -2.365
x2_e -1.432
x3_e -0.7684
xil  1
```

```
C =
      x1_e   x2_e   x3_e   xil
u1 -0.5388 -0.4173 -0.2481 0.5578
u2 -1.492  -1.388  -1.131  0.5869
```

```
D =
      e1
u1  0
u2  0
```

```
Input groups:
  Name      Channels
Error       1
```

```
Output groups:
  Name      Channels
Controls   1,2
```

Continuous-time model.

- Form the two-degree-of-freedom LQG servo controller by typing the following command:

```
KLQG2 = lqg(sys,QXU,QWV,QI,'2dof')
```

This command returns the following LQG servo controller:

```
A =
      x1_e   x2_e   x3_e   xil
x1_e -7.626 -5.068 -4.891 0.9018
x2_e -5.108 -4.146 -2.362 0.6762
x3_e -2.121 -2.604 -2.141 0.4088
xil   0       0       0       0
```

```
B =
      r1   y1
x1_e   0   2.365
x2_e   0   1.432
x3_e   0   0.7684
xil   1   -1
```

```
C =
```



```

          x1_e    x2_e    x3_e    x1l
u1  -0.5388  -0.4173  -0.2481  0.5578
u2  -1.492   -1.388   -1.131   0.5869

D =
      r1  y1
u1    0   0
u2    0   0

Input groups:
      Name      Channels
Setpoint      1
Measurement   2

Output groups:
      Name      Channels
Controls      1,2

Continuous-time model.

```

Tips

- `lqg` can be used for both continuous- and discrete-time plants. In discrete time, `lqg` uses $x[n|n-1]$ as its state estimate by default. To use $x[n|n]$ as the state estimate and compute the optimal LQG controller, use the 'current' input argument. For details on the state estimators, see `kalman`.
- To compute the LQG regulator, `lqg` uses the commands `lqr` and `kalman`. To compute the servo-controller, `lqg` uses the commands `lqi` and `kalman`.
- When you want more flexibility for designing regulators, you can use the `lqr`, `kalman`, and `lqgreg` commands. When you want more flexibility for designing servo controllers, you can use the `lqi`, `kalman`, and `lqgtrack` commands. For more information on using these commands and how to decide when to use them, see “Linear-Quadratic-Gaussian (LQG) Design for Regulation” and “Linear-Quadratic-Gaussian (LQG) Design of Servo Controller with Integral Action”.

Algorithms

The controller equations are:

- For continuous time:

$$dx_e = Ax_e + Bu + L(y - Cx_e - Du)$$

$$u = -K_x x_e - K_i x_i$$

- For discrete time:

$$x[n+1|n] = Ax[n|n-1] + Bu[n] + L(y[n] - Cx[n|n-1] - Du[n])$$

- Delayed estimator:

$$u[n] = -K_x x[n|n-1] - K_i x_i[n]$$

- Current estimator:

$$u[n] = -K_x x[n|n] - K_i x_i[n] - K_w w[n|n]$$

$$= -K_x x[n|n-1] - K_i x_i[n] - (K_x M_x + K_w M_w) y_{inn}[n]$$

$$y_{inn}[n] = y[n] - Cx[n|n-1] - Du[n]$$

Here,

- A , B , C , and D are the state-space matrices of the LQG regulator, `reg`.
- x_i is the integral of the tracking error $r - y$.
- K_x , K_w , K_i , L , M_x , and M_w are the controller and estimator gain matrices returned in `info`.

Version History

Introduced before R2006a

See Also

`lqr` | `lqi` | `kalman` | `lqry` | `ss` | `care` | `dare`

lqgreg

Form linear-quadratic-Gaussian (LQG) regulator

Syntax

```
r1qg = lqgreg(kest,k)
r1qg = lqgreg(kest,k,controls)
```

Description

`r1qg = lqgreg(kest,k)` returns the LQG regulator `r1qg` (a state-space model) given the Kalman estimator `kest` and the state-feedback gain matrix `k`. The same function handles both continuous- and discrete-time cases. Use consistent tools to design `kest` and `k`:

- Continuous regulator for continuous plant: use `lqr` or `lqry` and `kalman`
- Discrete regulator for discrete plant: use `dlqr` or `lqry` and `kalman`
- Discrete regulator for continuous plant: use `lqrd` and `kalmd`

In discrete time, `lqgreg` produces the regulator

- $u[n] = -K\hat{x}[n|n]$ when `kest` is the "current" Kalman estimator
- $u[n] = -K\hat{x}[n|n-1]$ when `kest` is the "delayed" Kalman estimator

For more information on Kalman estimators, see the `kalman` reference page.

`r1qg = lqgreg(kest,k,controls)` handles estimators that have access to additional deterministic known plant inputs u_d . The index vector `controls` then specifies which estimator inputs are the controls u , and the resulting LQG regulator `r1qg` has u_d and y as inputs (see the next figure).

Note Always use *positive* feedback to connect the LQG regulator to the plant.

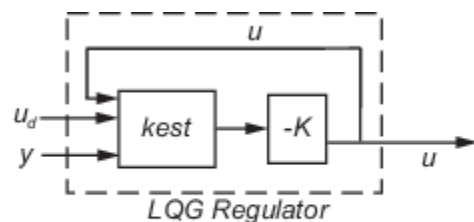

Examples

See the example "LQG Regulation: Rolling Mill Case Study".

Algorithms

`lqgreg` forms the linear-quadratic-Gaussian (LQG) regulator by connecting the Kalman estimator designed with `kalman` and the optimal state-feedback gain designed with `lqr`, `dlqr`, or `lqry`. The LQG regulator minimizes some quadratic cost function that trades off regulation performance and control effort. This regulator is dynamic and relies on noisy output measurements to generate the regulating commands.

In continuous time, the LQG regulator generates the commands

$$u = -K\hat{x}$$

where \hat{x} is the Kalman state estimate. The regulator state-space equations are

$$\begin{aligned}\dot{\hat{x}} &= [A - LC - (B - LD)K]\hat{x} + Ly \\ u &= -K\hat{x}\end{aligned}$$

where y is the vector of plant output measurements (see `kalman` for background and notation). The following diagram shows this dynamic regulator in relation to the plant.

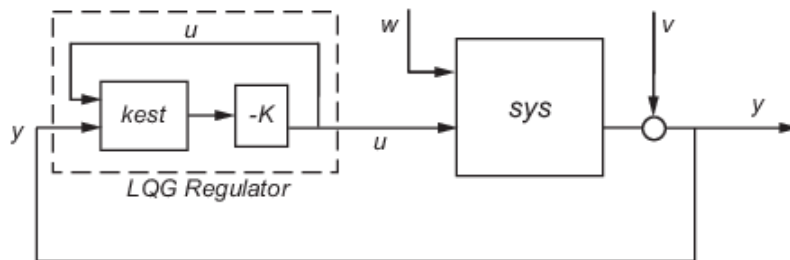

In discrete time, you can form the LQG regulator using either the delayed state estimate $\hat{x}[n|n-1]$ of $x[n]$, based on measurements up to $y[n-1]$, or the current state estimate $\hat{x}[n|n]$, based on all available measurements including $y[n]$. While the regulator

$$u[n] = -K\hat{x}[n|n-1]$$

is always well-defined, the *current regulator*

$$u[n] = -K\hat{x}[n|n]$$

is causal only when $I-KMD$ is invertible (see `kalman` for the notation). In addition, practical implementations of the current regulator should allow for the processing time required to compute $u[n]$ after the measurements $y[n]$ become available (this amounts to a time delay in the feedback loop).

For a discrete-time plant with equations:

$$\begin{aligned}x[n+1] &= Ax[n] + Bu[n] + Gw[n] \\ y[n] &= Cx[n] + Du[n] + Hw[n] + v[n] \quad \{\text{Measurements}\}\end{aligned}$$

connecting the "current" Kalman estimator to the LQR gain is optimal only when $E(w[n]v[n]) = 0$ and $y[n]$ does not depend on $w[n]$ ($H = 0$). If these conditions are not satisfied, compute the optimal LQG controller using `lqg`.

Version History

Introduced before R2006a

See Also

kalman | kalmd | lqr | dlqr | lqrd | lqry | reg

lqgtrack

Form Linear-Quadratic-Gaussian (LQG) servo controller

Syntax

```
C = lqgtrack(kest,k)
C = lqgtrack(kest,k,'2dof')
C = lqgtrack(kest,k,'1dof')
C = lqgtrack(kest,k,...CONTROLS)
```

Description

`lqgtrack` forms a Linear-Quadratic-Gaussian (LQG) servo controller with integral action for the loop shown in the following figure. This compensator ensures that the output y tracks the reference command r and rejects process disturbances w and measurement noise v . `lqgtrack` assumes that r and y have the same length.

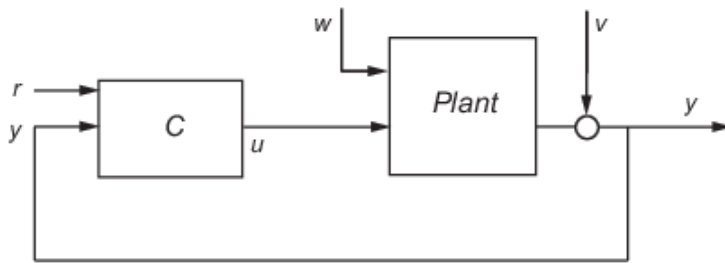

Note Always use positive feedback to connect the LQG servo controller C to the plant output y .

$C = \text{lqgtrack}(kest, k)$ forms a two-degree-of-freedom LQG servo controller C by connecting the Kalman estimator $kest$ and the state-feedback gain k , as shown in the following figure. C has inputs $[r; y]$ and generates the command $u = -K[\hat{x}; x_i]$, where \hat{x} is the Kalman estimate of the plant state, and x_i is the integrator output.

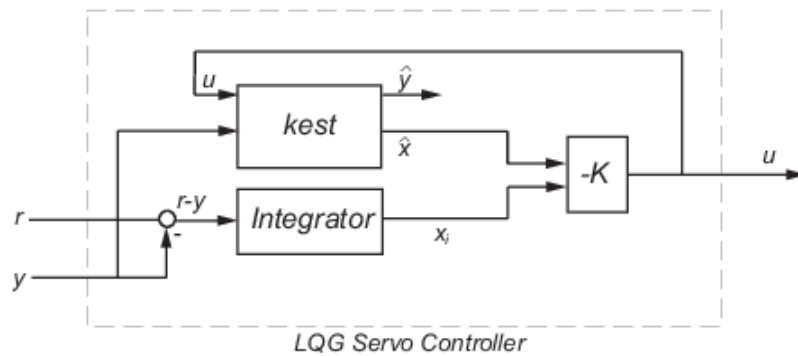

The size of the gain matrix k determines the length of x_i . x_i , y , and r all have the same length.

The two-degree-of-freedom LQG servo controller state-space equations are

$$\begin{bmatrix} \dot{\hat{x}} \\ \dot{x}_i \end{bmatrix} = \begin{bmatrix} A - BK_x - LC + LDK_x & -BK_i + LDK_i \\ 0 & 0 \end{bmatrix} \begin{bmatrix} \hat{x} \\ x_i \end{bmatrix} + \begin{bmatrix} 0 & L \\ I & -I \end{bmatrix} \begin{bmatrix} r \\ y \end{bmatrix}$$

$$u = [-K_x \ -K_i] \begin{bmatrix} \hat{x} \\ x_i \end{bmatrix}$$

Note The syntax `C = lqgtrack(kest,k,'2dof')` is equivalent to `C = lqgtrack(kest,k)`.

`C = lqgtrack(kest,k,'1dof')` forms a one-degree-of-freedom LQG servo controller `C` that takes the tracking error $e = r - y$ as input instead of $[r ; y]$, as shown in the following figure.

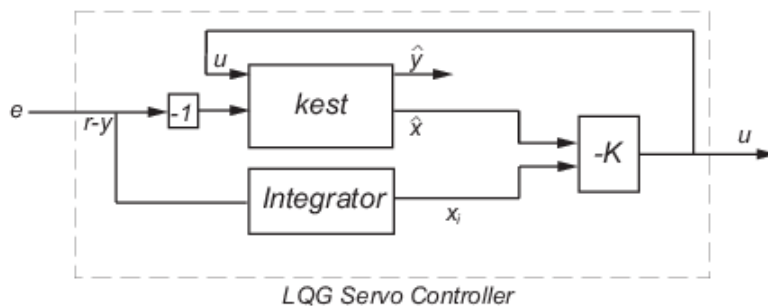

The one-degree-of-freedom LQG servo controller state-space equations are

$$\begin{bmatrix} \dot{\hat{x}} \\ \dot{x}_i \end{bmatrix} = \begin{bmatrix} A - BK_x - LC + LDK_x & -BK_i + LDK_i \\ 0 & 0 \end{bmatrix} \begin{bmatrix} \hat{x} \\ x_i \end{bmatrix} + \begin{bmatrix} -L \\ I \end{bmatrix} e$$

$$u = [-K_x \ -K_i] \begin{bmatrix} \hat{x} \\ x_i \end{bmatrix}$$

`C = lqgtrack(kest,k,...CONTROLS)` forms an LQG servo controller `C` when the Kalman estimator `kest` has access to additional known (deterministic) commands U_d of the plant. In the index vector `CONTROLS`, specify which inputs of `kest` are the control channels u . The resulting compensator `C` has inputs

- $[U_d ; r ; y]$ in the two-degree-of-freedom case
- $[U_d ; e]$ in the one-degree-of-freedom case

The corresponding compensator structure for the two-degree-of-freedom cases appears in the following figure.

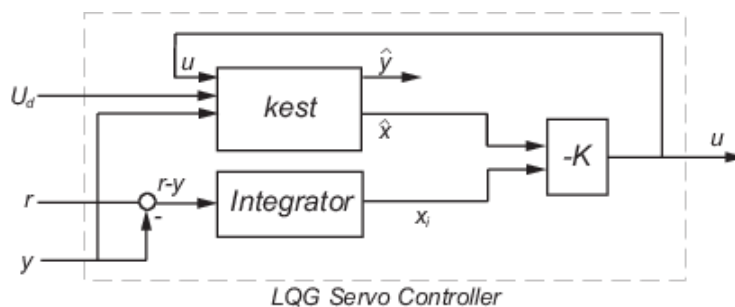

Examples

See the example “Design an LQG Servo Controller”.

Tips

You can use `lqgtrack` for both continuous- and discrete-time systems.

In discrete-time systems, integrators are based on forward Euler (see `lqi` for details). The state estimate \hat{x} is either $x[n|n]$ or $x[n|n-1]$, depending on the type of estimator (see `kalman` for details).

For a discrete-time plant with equations:

$$\begin{aligned}x[n + 1] &= Ax[n] + Bu[n] + Gw[n] \\y[n] &= Cx[n] + Du[n] + Hw[n] + v[n] \quad \{\text{Measurements}\}\end{aligned}$$

connecting the "current" Kalman estimator to the LQR gain is optimal only when $E(w[n]v[n]) = 0$ and $y[n]$ does not depend on $w[n]$ ($H = 0$). If these conditions are not satisfied, compute the optimal LQG controller using `lqg`.

Version History

Introduced in R2008b

See Also

`lqg` | `lqi` | `kalman` | `lqgreg` | `lqr`

lqi

Linear-Quadratic-Integral control

Syntax

`[K,S,e] = lqi(SYS,Q,R,N)`

Description

`lqi` computes an optimal state-feedback control law for the tracking loop shown in the following figure.

For a plant `sys` with the state-space equations (or their discrete counterpart):

$$\begin{aligned}\frac{dx}{dt} &= Ax + Bu \\ y &= Cx + Du\end{aligned}$$

the state-feedback control is of the form

$$u = -K[x; x_i]$$

where x_i is the integrator output. This control law ensures that the output y tracks the reference command r . For MIMO systems, the number of integrators equals the dimension of the output y .

`[K,S,e] = lqi(SYS,Q,R,N)` calculates the optimal gain matrix K , given a state-space model `SYS` for the plant and weighting matrices Q , R , N . The control law $u = -Kz = -K[x; x_i]$ minimizes the following cost functions (for $r = 0$)

- $J(u) = \int_0^{\infty} \{z^T Q z + u^T R u + 2z^T N u\} dt$ for continuous time
- $J(u) = \sum_{n=0}^{\infty} \{z^T Q z + u^T R u + 2z^T N u\}$ for discrete time

In discrete time, `lqi` computes the integrator output x_i using the forward Euler formula

$$x_i[n + 1] = x_i[n] + Ts(r[n] - y[n])$$

where Ts is the sample time of `SYS`.

When you omit the matrix N , N is set to 0. `lqi` also returns the solution S of the associated algebraic Riccati equation and the closed-loop eigenvalues e .

Limitations

For the following state-space system with a plant with augmented integrator:

$$\frac{\delta z}{\delta t} = A_a z + B_a u$$

$$y = C_a z + D_a u$$

The problem data must satisfy:

- The pair (A_a, B_a) is stabilizable.
- $R > 0$ and $Q - NR^{-1}N^T \geq 0$.
- $(Q - NR^{-1}N^T, A_a - B_a R^{-1}N^T)$ has no unobservable mode on the imaginary axis (or unit circle in discrete time).

Tips

`lqi` supports descriptor models with nonsingular E . The output `S` of `lqi` is the solution of the Riccati equation for the equivalent explicit state-space model

$$\frac{dx}{dt} = E^{-1}Ax + E^{-1}Bu$$

Version History

Introduced in R2008b

References

- [1] P. C. Young and J. C. Willems, "An approach to the linear multivariable servomechanism problem", *International Journal of Control*, Volume 15, Issue 5, May 1972 , pages 961-979.

See Also

`lqr` | `lqgreg` | `lqgtrack` | `lqg` | `care` | `dare`

lqr

Linear-Quadratic Regulator (LQR) design

Syntax

```
[K,S,P] = lqr(sys,Q,R,N)
[K,S,P] = lqr(A,B,Q,R,N)
```

Description

$[K,S,P] = \text{lqr}(\text{sys},Q,R,N)$ calculates the optimal gain matrix K , the solution S of the associated algebraic Riccati equation, and the closed-loop poles P for the continuous-time or discrete-time state-space model sys . Q and R are the weight matrices for states and inputs, respectively. The cross term matrix N is set to zero when omitted.

$[K,S,P] = \text{lqr}(A,B,Q,R,N)$ calculates the optimal gain matrix K , the solution S of the associated algebraic Riccati equation and the closed-loop poles P using the continuous-time state-space matrices A and B . This syntax is only valid for continuous-time models. For discrete-time models, use `dlqr`.

Examples

LQR Control for Inverted Pendulum Model

`pendulumModelCart.mat` contains the state-space model of an inverted pendulum on a cart where the outputs are the cart displacement x and the pendulum angle θ . The control input u is the horizontal force on the cart.

$$\begin{bmatrix} \dot{x} \\ \ddot{x} \\ \dot{\theta} \\ \ddot{\theta} \end{bmatrix} = \begin{bmatrix} 0 & 1 & 0 & 0 \\ 0 & -0.1 & 3 & 0 \\ 0 & 0 & 0 & 1 \\ 0 & -0.5 & 30 & 0 \end{bmatrix} \begin{bmatrix} x \\ \dot{x} \\ \theta \\ \dot{\theta} \end{bmatrix} + \begin{bmatrix} 0 \\ 2 \\ 0 \\ 5 \end{bmatrix} u$$

$$y = \begin{bmatrix} 1 & 0 & 0 & 0 \\ 0 & 0 & 1 & 0 \end{bmatrix} \begin{bmatrix} x \\ \dot{x} \\ \theta \\ \dot{\theta} \end{bmatrix} + \begin{bmatrix} 0 \\ 0 \end{bmatrix} u$$

First, load the state-space model `sys` to the workspace.

```
load('pendulumCartModel.mat','sys')
```

Since the outputs are x and θ , and there is only one input, use Bryson's rule to determine Q and R .

```
Q = [1,0,0,0; ...
     0,0,0,0; ...
     0,0,1,0; ...
     0,0,0,0];
R = 1;
```

Find the gain matrix K using `lqr`. Since N is not specified, `lqr` sets N to 0.

```
[K,S,P] = lqr(sys,Q,R)
```

```
K = 1x4
```

```
   -1.0000   -1.7559   16.9145    3.2274
```

```
S = 4x4
```

```
   1.5346    1.2127   -3.2274   -0.6851
   1.2127    1.5321   -4.5626   -0.9640
  -3.2274   -4.5626   26.5487    5.2079
  -0.6851   -0.9640    5.2079    1.0311
```

```
P = 4x1 complex
```

```
  -0.8684 + 0.8523i
  -0.8684 - 0.8523i
  -5.4941 + 0.4564i
  -5.4941 - 0.4564i
```

Although Bryson's rule usually provides satisfactory results, it is often just the starting point of a trial-and-error iterative design procedure to tune your closed-loop system response based on the design requirements.

LQR Control using State-Space Matrices

`aircraftPitchModel.mat` contains the state-space matrices of an aircraft where the input is the elevator deflection angle δ and the output is the aircraft pitch angle θ .

$$\begin{bmatrix} \dot{\alpha} \\ \dot{q} \\ \dot{\theta} \end{bmatrix} = \begin{bmatrix} -0.313 & 56.7 & 0 \\ -0.0139 & -0.426 & 0 \\ 0 & 56.7 & 0 \end{bmatrix} \begin{bmatrix} \alpha \\ q \\ \theta \end{bmatrix} + \begin{bmatrix} 0.232 \\ 0.0203 \\ 0 \end{bmatrix} [\delta]$$

$$y = [0 \ 0 \ 1] \begin{bmatrix} \alpha \\ q \\ \theta \end{bmatrix} + [0][\delta]$$

For a step reference of 0.2 radians, consider the following design criteria:

- Rise time less than 2 seconds
- Settling time less than 10 seconds
- Steady-state error less than 2%

Load the model data to the workspace.

```
load('aircraftPitchModel.mat')
```

Define the state-cost weighted matrix Q and the control weighted matrix R . Generally, you can use Bryson's Rule to define your initial weighted matrices Q and R . For this example, consider the output

vector C along with a scaling factor of 5 for matrix Q and choose R as 1. R is a scalar since the system has only one input.

$$R = 1$$

$$R = 1$$

$$Q1 = 2 * C' * C$$

$$Q1 = 3 \times 3$$

$$\begin{bmatrix} 0 & 0 & 0 \\ 0 & 0 & 0 \\ 0 & 0 & 2 \end{bmatrix}$$

Compute the gain matrix using `lqr`.

$$[K1, S1, P1] = \text{lqr}(A, B, Q1, R);$$

Check the closed-loop step response with the generated gain matrix $K1$.

$$\text{sys1} = \text{ss}(A - B * K1, B, C, D);$$

$$\text{step}(\text{sys1})$$

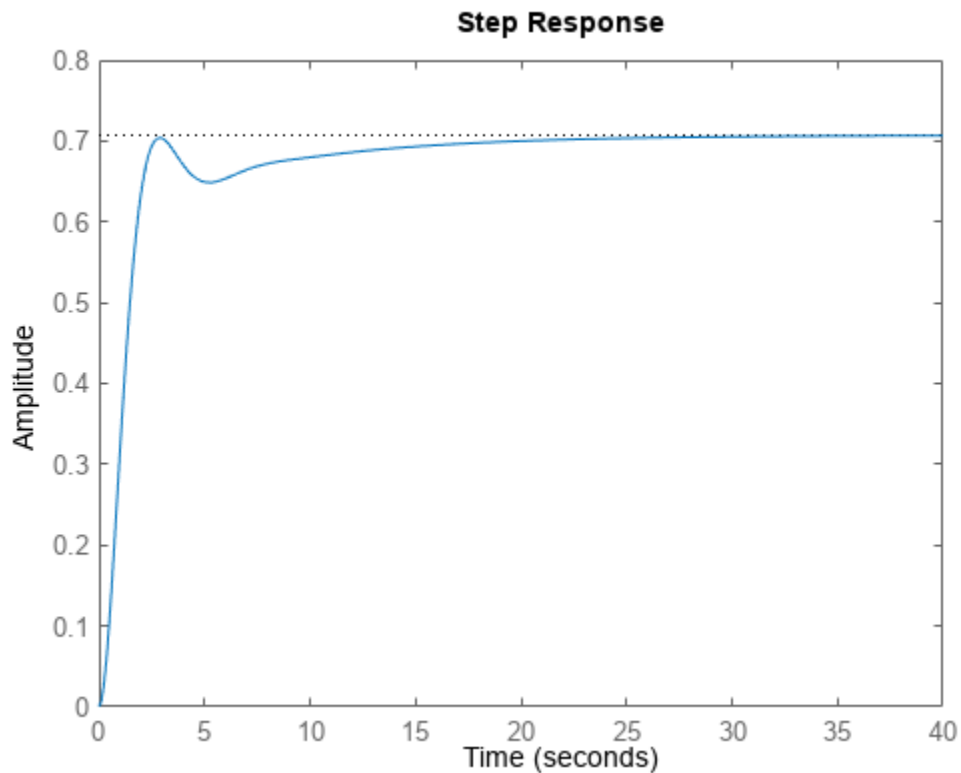

Since this response does not meet the design goals, increase the scaling factor to 25, compute the gain matrix $K2$, and check the closed-loop step response for gain matrix $K2$.

$$Q2 = 25 * C' * C$$

```
Q2 = 3x3
```

```
0    0    0
0    0    0
0    0    25
```

```
[K2,S2,P2] = lqr(A,B,Q2,R);
sys2 = ss(A-B*K2,B,C,D);
step(sys2)
```

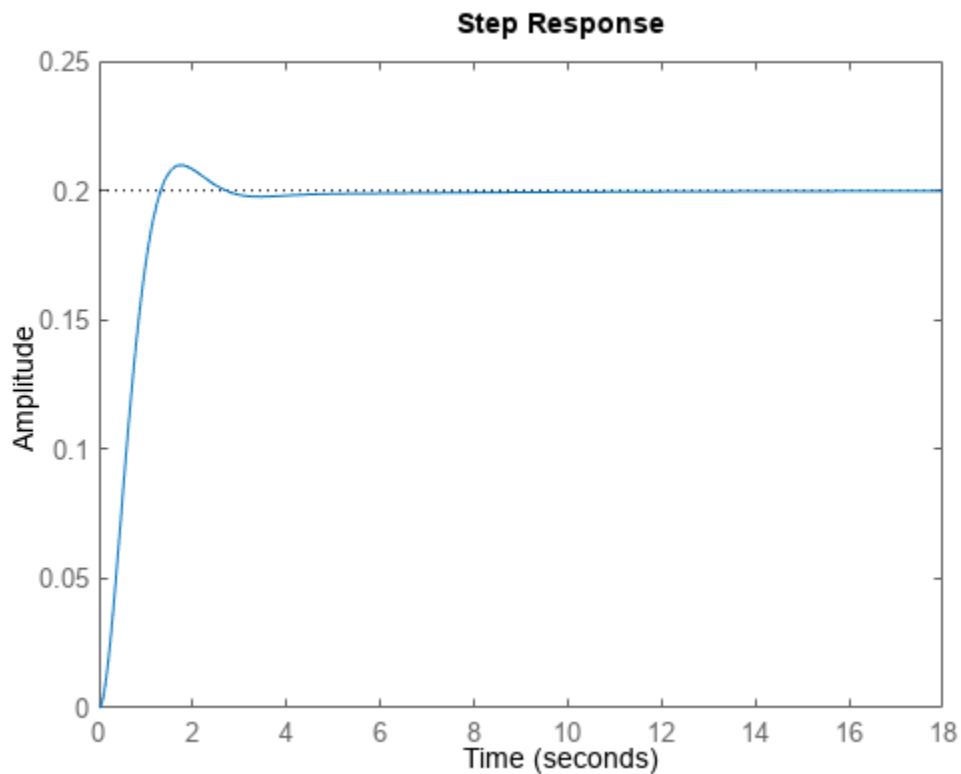

In the closed-loop step response plot, the rise time, settling time, and steady-state error meet the design goals.

Input Arguments

sys — Dynamic system model

ss model object

Dynamic system model, specified as an ss model object.

A — State matrix

n-by-n matrix

State matrix, specified as an n-by-n matrix, where n is the number of states.

B – Input-to-state matrix

n-by-m matrix

Input-to-state matrix, specified as an n-by-m input-to-state matrix, where m is the number of inputs.

Q – State-cost weighted matrix

matrix

State-cost weighted matrix, specified as an n-by-n matrix, where n is the number of states. You can use Bryson's rule to set the initial values of Q given by:

$$Q_{i,i} = \frac{1}{\text{maximum acceptable value of } (error_{states})^2}, i \in \{1, 2, \dots, n\}$$

$$Q = \begin{bmatrix} Q_{1,1} & 0 & \dots & 0 \\ 0 & Q_{2,2} & \dots & 0 \\ 0 & 0 & \ddots & \vdots \\ 0 & 0 & \dots & Q_{n,n} \end{bmatrix}$$

Here, n is the number of states.

R – Input-cost weighted matrix

scalar | matrix

Input-cost weighted matrix, specified as a scalar or a matrix of the same size as D'D. Here, D is the feed-through state-space matrix. You can use Bryson's rule to set the initial values of R given by:

$$R_{j,j} = \frac{1}{\text{maximum acceptable value of } (error_{inputs})^2}, j \in \{1, 2, \dots, m\}$$

$$R = \begin{bmatrix} R_{1,1} & 0 & \dots & 0 \\ 0 & R_{2,2} & \dots & 0 \\ 0 & 0 & \ddots & \vdots \\ 0 & 0 & \dots & R_{m,m} \end{bmatrix}$$

Here, m is the number of inputs.

N – Optional cross term matrix

0 (default) | matrix

Optional cross term matrix, specified as a matrix. If N is not specified, then lqr sets N to 0 by default.

Output Arguments**K – Optimal gain**

row vector

Optimal gain of the closed-loop system, returned as a row vector of size n, where n is the number of states.

S – Solution of the associated algebraic Riccati equation

matrix

Solution of the associated algebraic Riccati equation, returned as an n-by-n matrix, where n is the number of states. In other words, S is the same dimension as state-space matrix A. For more information, see `icare` and `idare`.

P — Poles of the closed-loop system

column vector

Poles of the closed-loop system, returned as a column vector of size n, where n is the number of states.

Limitations

The input data must satisfy the following conditions:

- The pair A and B must be stabilizable.
- $[Q, N; N', R]$ must be nonnegative definite.
- $R > 0$ and $Q - NR^{-1}N^T \geq 0$.
- $(Q - NR^{-1}N^T, A - BR^{-1}N^T)$ has no unobservable mode on the imaginary axis (or unit circle in discrete time).

Tips

- `lqr` supports descriptor models with nonsingular E. The output S of `lqr` is the solution of the algebraic Riccati equation for the equivalent explicit state-space model:

$$\frac{dx}{dt} = E^{-1}Ax + E^{-1}Bu$$

Algorithms

For continuous-time systems, `lqr` computes the state-feedback control $u = -Kx$ that minimizes the quadratic cost function

$$J(u) = \int_0^{\infty} (x^T Q x + u^T R u + 2x^T N u) dt$$

subject to the system dynamics $\dot{x} = Ax + Bu$.

In addition to the state-feedback gain K, `lqr` returns the solution S of the associated algebraic Riccati equation

$$A^T S + SA - (SB + N)R^{-1}(B^T S + N^T) + Q = 0$$

and the closed-loop poles $P = \text{eig}(A - BK)$. The gain matrix K is derived from S using

$$K = R^{-1}(B^T S + N^T).$$

For discrete-time systems, `lqr` computes the state-feedback control $u_n = -Kx_n$ that minimizes

$$J = \sum_{n=0}^{\infty} \{x^T Q x + u^T R u + 2x^T N u\}$$

subject to the system dynamics $x_{n+1} = Ax_n + Bu_n$.

In all cases, when you omit the cross term matrix N, lqr sets N to 0.

Version History

Introduced before R2006a

See Also

icare | idare | dlqr | lqg | lqi | lqrd | lqry | lqgreg | lqgtrack

Topics

“Regulate Pressure in Drum Boiler”

lqrd

Design discrete linear-quadratic (LQ) regulator for continuous plant

Syntax

```
lqrd
[Kd,S,e] = lqrd(A,B,Q,R,Ts)
[Kd,S,e] = lqrd(A,B,Q,R,N,Ts)
```

Description

`lqrd` designs a discrete full-state-feedback regulator that has response characteristics similar to a continuous state-feedback regulator designed using `lqr`. This command is useful to design a gain matrix for digital implementation after a satisfactory continuous state-feedback gain has been designed.

`[Kd,S,e] = lqrd(A,B,Q,R,Ts)` calculates the discrete state-feedback law

$$u[n] = -K_d x[n]$$

that minimizes a discrete cost function equivalent to the continuous cost function

$$J = \int_0^{\infty} (x^T Q x + u^T R u) dt$$

The matrices `A` and `B` specify the continuous plant dynamics

$$\dot{x} = Ax + Bu$$

and `Ts` specifies the sample time of the discrete regulator. Also returned are the solution `S` of the discrete Riccati equation for the discretized problem and the discrete closed-loop eigenvalues `e = eig(Ad-Bd*Kd)`.

`[Kd,S,e] = lqrd(A,B,Q,R,N,Ts)` solves the more general problem with a cross-coupling term in the cost function.

$$J = \int_0^{\infty} (x^T Q x + u^T R u + 2x^T N u) dt$$

Limitations

The discretized problem data should meet the requirements for `dlqr`.

Algorithms

The equivalent discrete gain matrix `Kd` is determined by discretizing the continuous plant and weighting matrices using the sample time `Ts` and the zero-order hold approximation.

With the notation

$$\Phi(\tau) = e^{A\tau}, \quad A_d = \Phi(T_s)$$

$$\Gamma(\tau) = \int_0^\tau e^{A\eta} B d\eta, \quad B_d = \Gamma(T_s)$$

the discretized plant has equations

$$x[n + 1] = A_d x[n] + B_d u[n]$$

and the weighting matrices for the equivalent discrete cost function are

$$\begin{bmatrix} Q_d & N_d \\ N_d^T & R_d \end{bmatrix} = \int_0^{T_s} \begin{bmatrix} \Phi^T(\tau) & 0 \\ \Gamma^T(\tau) & I \end{bmatrix} \begin{bmatrix} Q & N \\ N^T & R \end{bmatrix} \begin{bmatrix} \Phi(\tau) & \Gamma(\tau) \\ 0 & I \end{bmatrix} d\tau$$

The integrals are computed using matrix exponential formulas due to Van Loan (see [2]). The plant is discretized using `c2d` and the gain matrix is computed from the discretized data using `dlqr`.

Version History

Introduced before R2006a

References

- [1] Franklin, G.F., J.D. Powell, and M.L. Workman, *Digital Control of Dynamic Systems*, Second Edition, Addison-Wesley, 1980, pp. 439-440.
- [2] Van Loan, C.F., "Computing Integrals Involving the Matrix Exponential," *IEEE Trans. Automatic Control*, AC-23, June 1978.

See Also

`c2d` | `dlqr` | `kalmd` | `lqr`

lqry

Form linear-quadratic (LQ) state-feedback regulator with output weighting

Syntax

`[K,S,e] = lqry(sys,Q,R,N)`

Description

Given the plant

$$\begin{aligned}\dot{x} &= Ax + Bu \\ y &= Cx + Du\end{aligned}$$

or its discrete-time counterpart, `lqry` designs a state-feedback control

$$u = -Kx$$

that minimizes the quadratic cost function with output weighting

$$J(u) = \int_0^{\infty} (y^T Q y + u^T R u + 2y^T N u) dt$$

(or its discrete-time counterpart). The function `lqry` is equivalent to `lqr` or `dlqr` with weighting matrices:

$$\begin{bmatrix} \bar{Q} & \bar{N} \\ \bar{N}^T & \bar{R} \end{bmatrix} = \begin{bmatrix} C^T & 0 \\ D^T & I \end{bmatrix} \begin{bmatrix} Q & N \\ N^T & R \end{bmatrix} \begin{bmatrix} C & D \\ 0 & I \end{bmatrix}$$

`[K,S,e] = lqry(sys,Q,R,N)` returns the optimal gain matrix `K`, the Riccati solution `S`, and the closed-loop eigenvalues `e = eig(A-B*K)`. The state-space model `sys` specifies the continuous- or discrete-time plant data (A, B, C, D) . The default value `N=0` is assumed when `N` is omitted.

Examples

See “LQG Design for the x-Axis” for an example.

Limitations

The data $A, B, \bar{Q}, \bar{R}, \bar{N}$ must satisfy the requirements for `lqr` or `dlqr`.

Version History

Introduced before R2006a

See Also

`lqr` | `dlqr` | `kalman` | `lqgreg`

lsim

Plot simulated time response of dynamic system to arbitrary inputs; simulated response data

Syntax

```
lsim(sys,u,t)
lsim(sys,u,t,x0)
lsim(sys,u,t,x0,method)
lsim(sys1,sys2,...,sysN,u,t,___)
lsim(sys1,LineStyle1,...,sysN,LineStyleN,___)
```

```
y = lsim(sys,u,t)
y = lsim(sys,u,t,x0)
y = lsim(sys,u,t,x0,method)
[y,tOut,x] = lsim(___)
```

```
lsim(sys)
```

Description

Response Plots

`lsim(sys,u,t)` plots the simulated time response of the dynamic system model `sys` to the input history `(t,u)`. The vector `t` specifies the time samples for the simulation. For single-input systems, the input signal `u` is a vector of the same length as `t`. For multi-input systems, `u` is an array with as many rows as there are time samples (`length(t)`) and as many columns as there are inputs to `sys`.

`lsim(sys,u,t,x0)` further specifies a vector `x0` of initial state values, when `sys` is a state-space model.

`lsim(sys,u,t,x0,method)` specifies how `lsim` interpolates the input values between samples, when `sys` is a continuous-time model.

`lsim(sys1,sys2,...,sysN,u,t,___)` simulates the responses of several dynamic system models to the same input history and plots these responses on a single figure. All systems must have the same number of inputs and outputs. You can also use the `x0` and `method` input arguments when computing the responses of multiple models.

`lsim(sys1,LineStyle1,...,sysN,LineStyleN,___)` specifies a color, line style, and marker for each system in the plot. When you need additional plot customization options, use `lsimplot` instead.

Response Data

`y = lsim(sys,u,t)` returns the system response `y`, sampled at the same times `t` as the input. For single-output systems, `y` is a vector of the same length as `t`. For multi-output systems, `y` is an array having as many rows as there are time samples (`length(t)`) and as many columns as there are outputs in `sys`. This syntax does not generate a plot.

`y = lsim(sys,u,t,x0)` further specifies a vector `x0` of initial state values, when `sys` is a state-space model.

`y = lsim(sys,u,t,x0,method)` specifies how `lsim` interpolates the input values between samples, when `sys` is a continuous-time model.

`[y,tOut,x] = lsim(____)` returns the state trajectories `x`, when `sys` is a state-space model. `x` is an array with as many rows as there are time samples and as many columns as there are states in `sys`. This syntax also returns the time samples used for the simulation in `tOut`.

Linear Simulation Tool

`lsim(sys)` opens the Linear Simulation Tool. For more information about using this tool for linear analysis, see Working with the Linear Simulation Tool.

Examples

Simulated Response to Arbitrary Input Signal

Consider the following transfer function.

```
sys = tf(3,[1 2 3])
```

```
sys =
```

```
      3
-----
s^2 + 2 s + 3
```

Continuous-time transfer function.

To compute the response of this system to an arbitrary input signal, provide `lsim` with a vector of the times `t` at which you want to compute the response and a vector `u` containing the corresponding signal values. For instance, plot the system response to a ramping step signal that starts at 0 at time `t = 0`, ramps from 0 at `t = 1` to 1 at `t = 2`, and then holds steady at 1. Define `t` and compute the values of `u`.

```
t = 0:0.04:8; % 201 points
u = max(0,min(t-1,1));
```

Use `lsim` without an output argument to plot the system response to the signal.

```
lsim(sys,u,t)
grid on
```

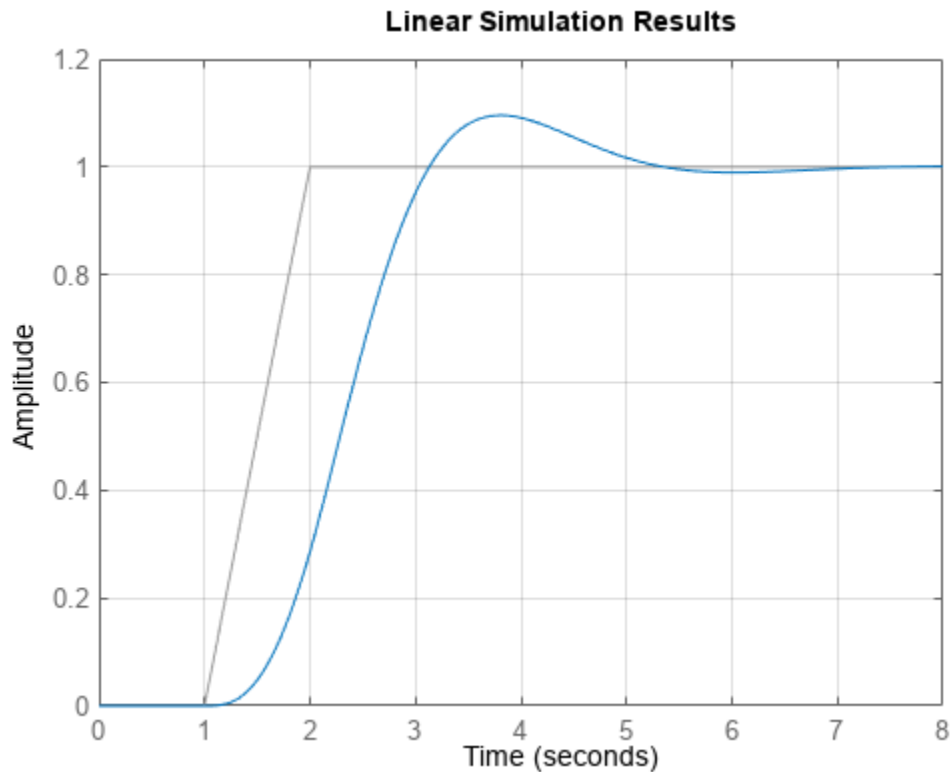

The plot shows the applied input (u, t) in gray and the system response in blue.

Use `lsim` with an output argument to obtain the simulated response data.

```
y = lsim(sys,u,t);
size(y)
```

```
ans = 1x2
```

```
201    1
```

The vector y contains the simulated response at the corresponding times in t .

Response to Periodic Signal

Use `gensig` to create periodic input signals such as sine waves and square waves for use with `lsim`. Simulate the response to a square wave of the following SISO state-space model.

```
A = [-3 -1.5; 5 0];
B = [1; 0];
C = [0.5 1.5];
D = 0;
sys = ss(A,B,C,D);
```

For this example, create a square wave with a period of 10 s and a duration of 20 s.

```
[u,t] = gensig("square",10,20);
```

`gensig` returns the vector `t` of time steps and the vector `u` containing the corresponding values of the input signal. (If you do not specify a sample time for `t`, then `gensig` generates 64 samples per period.) Use these with `lsim` and plot the system response.

```
lsim(sys,u,t)
grid on
```

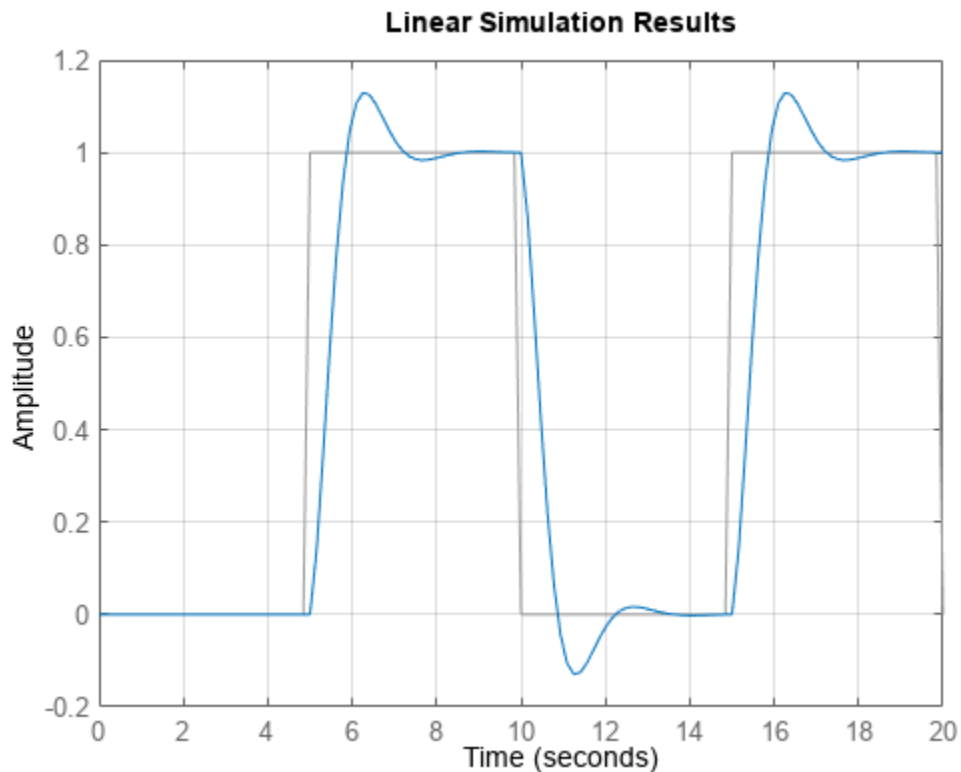

The plot shows the applied square wave in gray and the system response in blue. Call `lsim` with an output argument to obtain the response values at each point in `t`.

```
[y,~] = lsim(sys,u,t);
```

Response of Discrete-Time System

When you simulate the response of a discrete-time system, the time vector `t` must be of the form `Ti:dT:Tf`, where `dT` is the sample time of the model. Simulate the response of the following discrete-time transfer function to a ramp step input.

```
sys = tf([0.06 0.05],[1 -1.56 0.67],0.05);
```

This transfer function has a sample time of 0.05 s. Use the same sample time to generate the time vector `t` and a ramped step signal `u`.

```
t = 0:0.05:4;  
u = max(0,min(t-1,1));
```

Plot the system response.

```
lsim(sys,u,t)
```

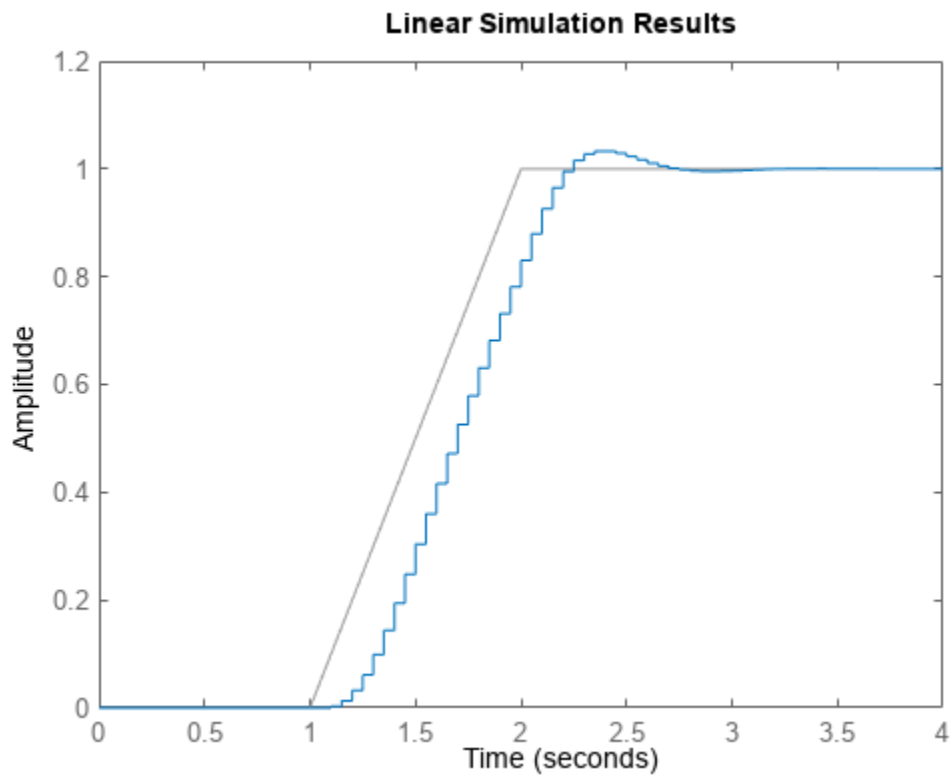

To simulate the response of a discrete-time system to a periodic input signal, use the same sample time with `gensig` to generate the input. For instance, simulate the system response to a sine wave with period of 1 s and a duration of 4 s.

```
[u,t] = gensig("sine",1,4,0.05);
```

Plot the system response.

```
lsim(sys,u,t)
```

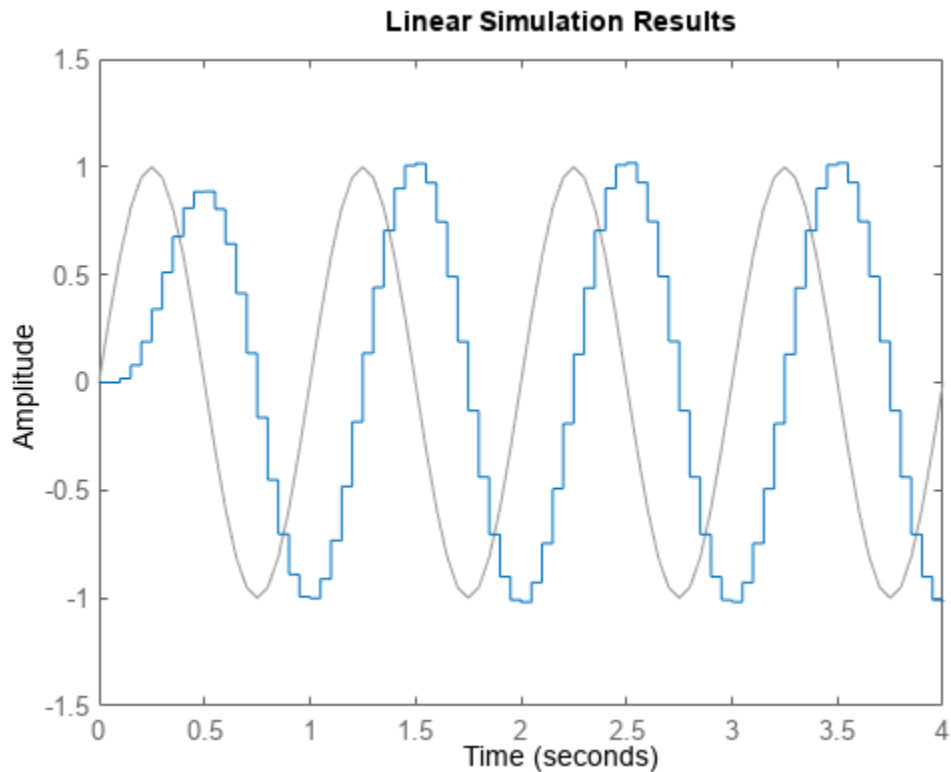

Plot Response of Multiple Systems to Same Input

`lsim` allows you to plot the simulated responses of multiple dynamic systems on the same axis. For instance, compare the closed-loop response of a system with a PI controller and a PID controller. Create a transfer function of the system and tune the controllers.

```
H = tf(4,[1 10 25]);
C1 = pidtune(H, 'PI');
C2 = pidtune(H, 'PID');
```

Form the closed-loop systems.

```
sys1 = feedback(H*C1,1);
sys2 = feedback(H*C2,1);
```

Plot the responses of both systems to a square wave with a period of 4 s.

```
[u,t] = gensig("square",4,12);
lsim(sys1,sys2,u,t)
grid on
legend("PI","PID")
```

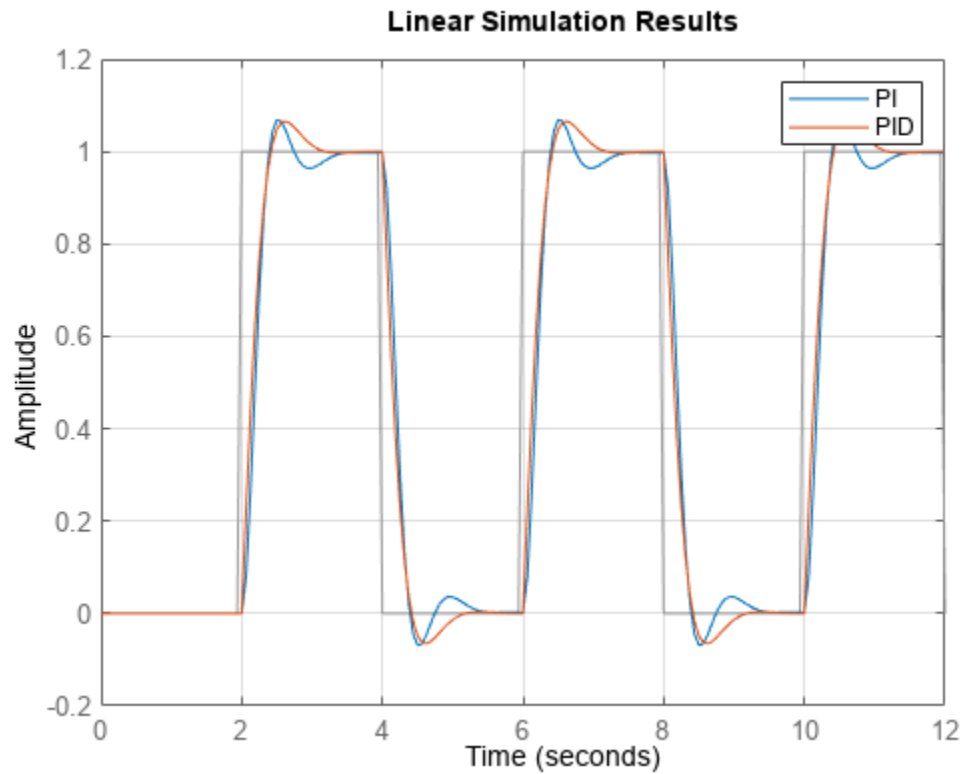

By default, `lsim` chooses distinct colors for each system that you plot. You can specify colors and line styles using the `LineStyle` input argument.

```
lsim(sys1, "r--", sys2, "b", u, t)
grid on
legend("PI", "PID")
```

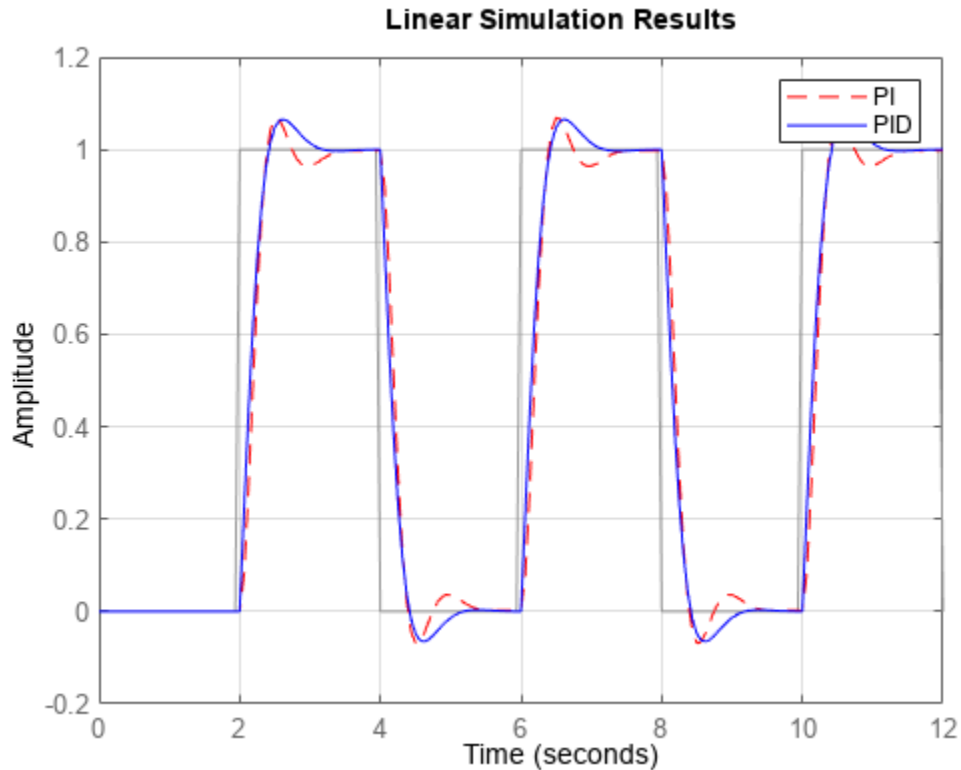

The first LineSpec "r- -" specifies a dashed red line for the response with the PI controller. The second LineSpec "b" specifies a solid blue line for the response with the PID controller. The legend reflects the specified colors and line styles. For more plot customization options, use `lsimplot`.

Plot Simulated Response of MIMO System

In a MIMO system, at each time step t , the input $u(t)$ is a vector whose length is the number of inputs. To use `lsim`, you specify u as a matrix with dimensions N_t -by- N_u , where N_u is the number of system inputs and N_t is the length of t . In other words, each column of u is the input signal applied to the corresponding system input. For instance, to simulate a system with four inputs for 201 time steps, provide u as a matrix of four columns and 201 rows, where each row $u(i, :)$ is the vector of input values at the i th time step; each column $u(:, j)$ is the signal applied at the j th input.

Similarly, the output $y(t)$ computed by `lsim` is a matrix whose columns represent the signal at each system output. When you use `lsim` to plot the simulated response, `lsim` provides separate axes for each output, representing the system response in each output channel to the input $u(t)$ applied at all inputs.

Consider the two-input, three-output state-space model with the following state-space matrices.

$$A = \begin{bmatrix} -1.5 & -0.2 & 1.0; \\ -0.2 & -1.7 & 0.6; \\ 1.0 & 0.6 & -1.4; \end{bmatrix}$$

```

B = [ 1.5  0.6;
      -1.8 1.0;
       0   0 ];

C = [ 0   -0.5 -0.1;
      0.35 -0.1 -0.15;
      0.65  0   0.6];

D = [ 0.5  0;
      0.05 0.75;
       0   0];

sys = ss(A,B,C,D);

```

Plot the response of `sys` to a square wave of period 4 s, applied to the first input `sys` and a pulse applied to the second input every 3 s. To do so, create column vectors representing the square wave and the pulsed signal using `gensig`. Then stack the columns into an input matrix. To ensure the two signals have the same number of samples, specify the same end time and sample time.

```

Tf = 10;
Ts = 0.1;
[uSq,t] = gensig("square",4,Tf,Ts);
[uP,~] = gensig("pulse",3,Tf,Ts);
u = [uSq uP];
lsim(sys,u,t)

```

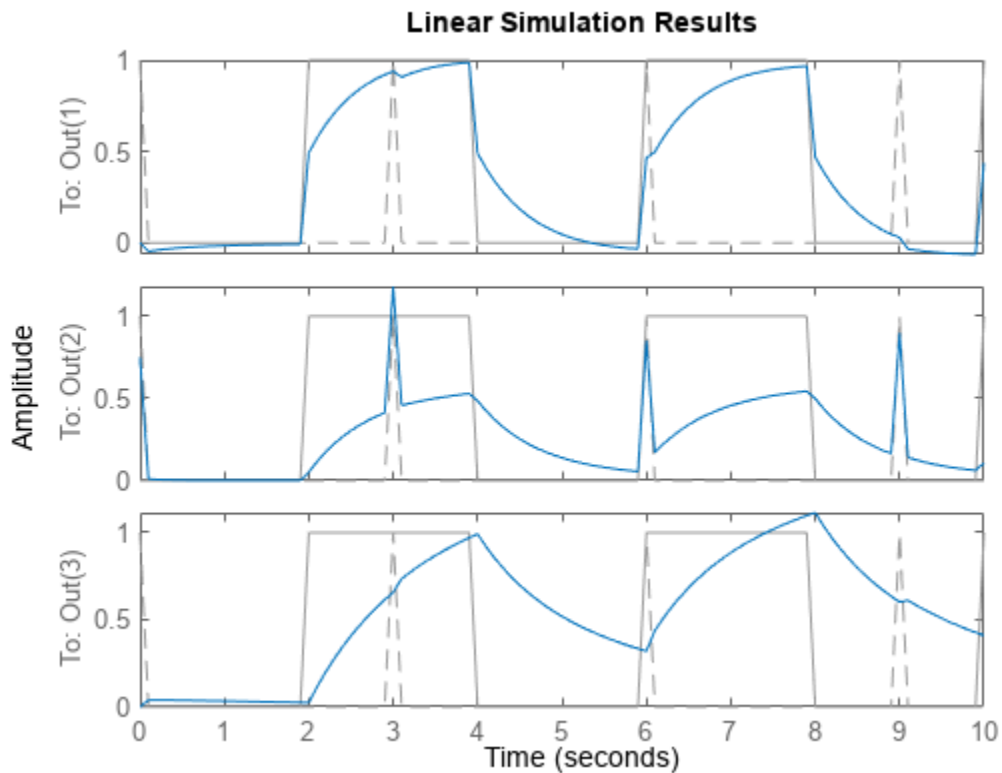

Each axis shows the response of one of the three system outputs to the signals u applied at all inputs. Each plot also shows all input signals in gray.

Plot System Evolution from Initial Condition

By default, `lsim` simulates the model assuming all states are zero at the start of the simulation. When simulating the response of a state-space model, use the optional `x0` input argument to specify nonzero initial state values. Consider the following two-state SISO state-space model.

```
A = [-1.5 -3;  
      3   -1];  
B = [1.3; 0];  
C = [1.15 2.3];  
D = 0;  
  
sys = ss(A,B,C,D);
```

Suppose that you want to allow the system to evolve from a known set of initial states with no input for 2 s, and then apply a unit step change. Specify the vector `x0` of initial state values, and create the input vector.

```
x0 = [-0.2 0.3];  
t = 0:0.05:8;  
u = zeros(length(t),1);  
u(t>=2) = 1;  
lsim(sys,u,t,x0)  
grid on
```

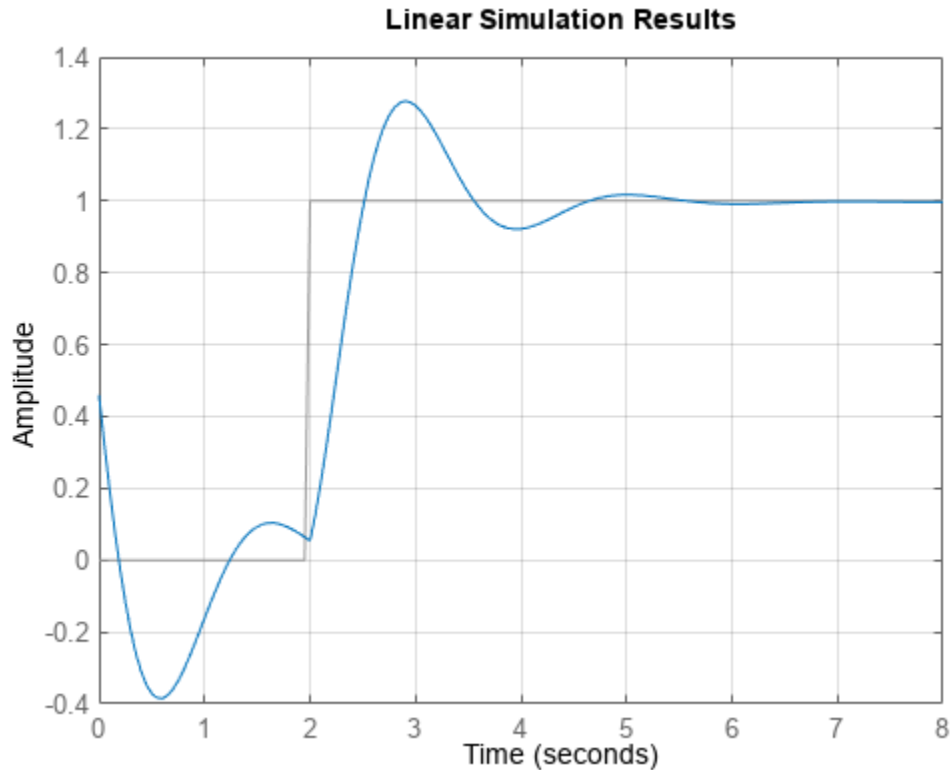

The first half of the plot shows the free evolution of the system from the initial state values $[-0.2 \ 0.3]$. At $t = 2$ there is a step change to the input, and the plot shows the system response to this new signal beginning from the state values at that time.

Extract Simulated Response Data

When you use `lsim` with output arguments, it returns the simulated response data in an array. For a SISO system, the response data is returned as a column vector of the same length as `t`. For instance, extract the response of a SISO system to a square wave. Create the square wave using `gensig`.

```
sys = tf([2 5 1],[1 2 3]);
[u,t] = gensig("square",4,10,0.05);
[y,t] = lsim(sys,u,t);
size(y)
```

```
ans = 1x2
```

```
201    1
```

The vector `y` contains the simulated response at each time step in `t`. (`lsim` returns the time vector `t` as a convenience.)

For a MIMO system, the response data is returned in an array of dimensions N -by- N_y -by- N_u , where N_y and N_u are the number of outputs and inputs of the dynamic system. For instance, consider the following state-space model, representing a three-state system with two inputs and three outputs.

```
A = [-1.5  -0.2  1.0;
     -0.2  -1.7  0.6;
      1.0   0.6 -1.4];
```

```
B = [ 1.5  0.6;
     -1.8  1.0;
       0   0  ];
```

```
C = [ 0  -0.1 -0.2;
     0.7 -0.2 -0.3;
    -0.65 0  -0.6];
```

```
D = [ 0.1  0;
     0.1  1.5;
       0   0];
```

```
sys = ss(A,B,C,D);
```

Extract the responses of the three output channels to the square wave applied at both inputs.

```
uM = [u u];
[y,t] = lsim(sys,uM,t);
size(y)
```

```
ans = 1×2
```

```
201    3
```

$y(:,j)$ is a column vector containing response at the j th output to the square wave applied to both inputs. That is, $y(i,:)$ is a vector of three values, the output values at the i th time step.

Because `sys` is a state-space model, you can extract the time evolution of the state values in response to the input signal.

```
[y,t,x] = lsim(sys,uM,t);
size(x)
```

```
ans = 1×2
```

```
201    3
```

Each row of `x` contains the state values $[x_1, x_2, x_3]$ at the corresponding time in `t`. In other words, $x(i,:)$ is the state vector at the i th time step. Plot the state values.

```
plot(t,x)
```

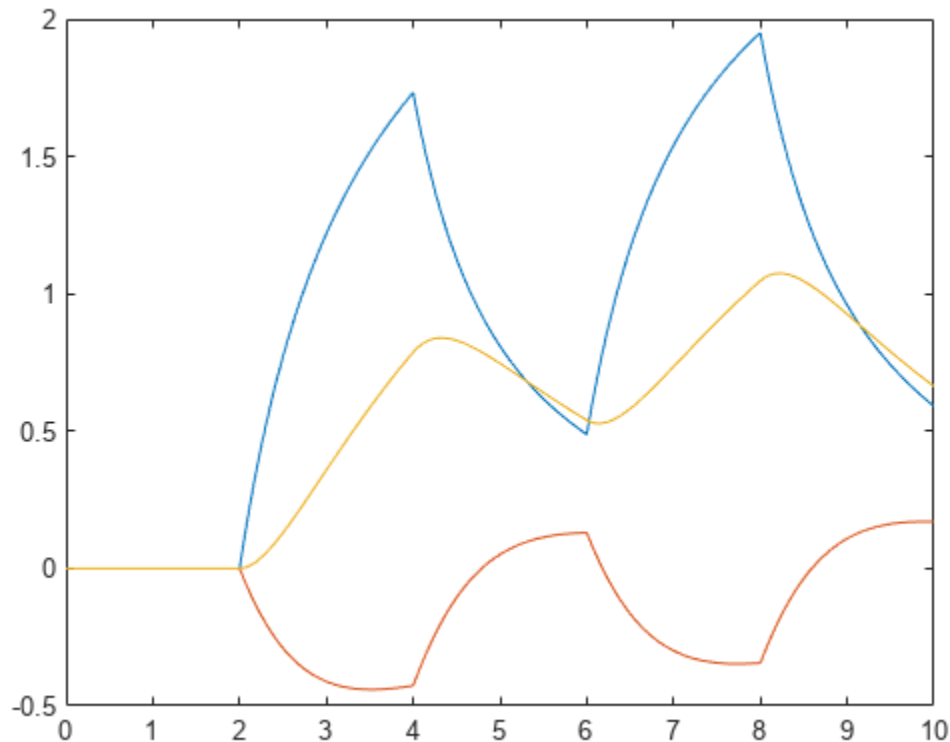
Response of Systems in Model Array

The example Plot Response of Multiple Systems to Same Input shows how to plot responses of several individual systems on a single axis. When you have multiple dynamic systems arranged in a model array, `lsim` plots all their responses at once.

Create a model array. For this example, use a one-dimensional array of second-order transfer functions having different natural frequencies. First, preallocate memory for the model array. The following command creates a 1-by-5 row of zero-gain SISO transfer functions. The first two dimensions represent the model outputs and inputs. The remaining dimensions are the array dimensions. (For more information about model arrays and how to create them, see “Model Arrays”.)

```
sys = tf(zeros(1,1,1,5));
```

Populate the array.

```
w0 = 1.5:1:5.5;    % natural frequencies
zeta = 0.5;       % damping constant
for i = 1:length(w0)
    sys(:,:,1,i) = tf(w0(i)^2,[1 2*zeta*w0(i) w0(i)^2]);
end
```

Plot the responses of all models in the array to a square wave input.

```
[u,t] = gensig("square",5,15);
lsim(sys,u,t)
```

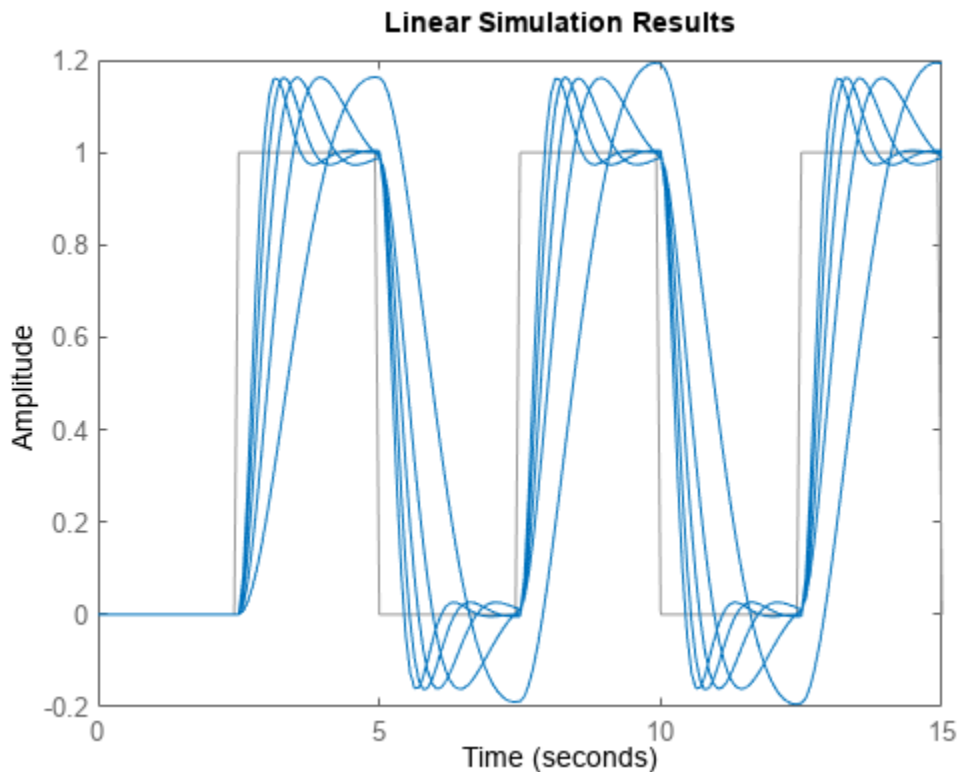

`lsim` uses the same line style for the responses of all entries in the array. One way to distinguish among entries is to use the `SamplingGrid` property of dynamic system models to associate each entry in the array with the corresponding $w\theta$ value.

```
sys.SamplingGrid = struct('frequency',w0);
```

Now, when you plot the responses in a MATLAB figure window, you can click a trace to see which frequency value it corresponds to.

Simulate Response of Identified Model

Load estimation data to estimate a model.

```
load(fullfile(matlabroot,'toolbox','ident','iddemos','data','dcmotordata'));
z = iddata(y,u,0.1,'Name','DC-motor');
```

`z` is an `iddata` object that stores the one-input two-output estimation data with a sample time of 0.1 s.

Estimate a state-space model of order 4 using estimation data `z`.

```
[sys,x0] = n4sid(z,4);
```

`sys` is the estimated model and `x0` is the estimated initial states.

Simulate the response of `sys` using the same input data as the one used for estimation and the initial states returned by the estimation command.

```
[y,t,x] = lsim(sys,z.InputData,[],x0);
```

Here, `y` is the system response, `t` is the time vector used for simulation, and `x` is the state trajectory.

Compare the simulated response `y` to the measured response `z.OutputData` for both outputs.

```
subplot(211), plot(t,z.OutputData(:,1),'k',t,y(:,1),'r')
legend('Measured','Simulated')
subplot(212), plot(t,z.OutputData(:,2),'k',t,y(:,2),'r')
legend('Measured','Simulated')
```

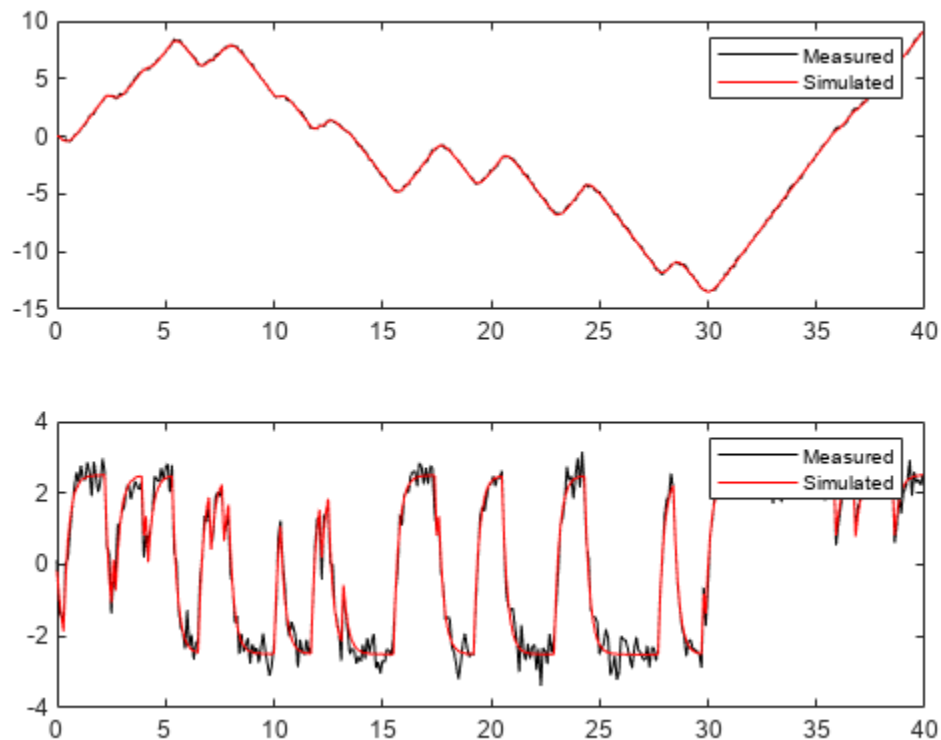

Effect of Sample Time on Simulation

The choice of sample time can drastically affect simulation results. To illustrate why, consider the following second-order model.

$$\text{sys}(s) = \frac{\omega^2}{s^2 + 2s + \omega^2}, \quad \omega = 62.83.$$

Simulate the response of this model to a square wave with period 1 s, using a sample time of 0.1 s.

```

w2 = 62.83^2;
sys = tf(w2,[1 2 w2]);

tau = 1;
Tf = 5;
Ts = 0.1;
[u,t] = gensig("square",tau,Tf,Ts);
lsim(sys,u,t)

```

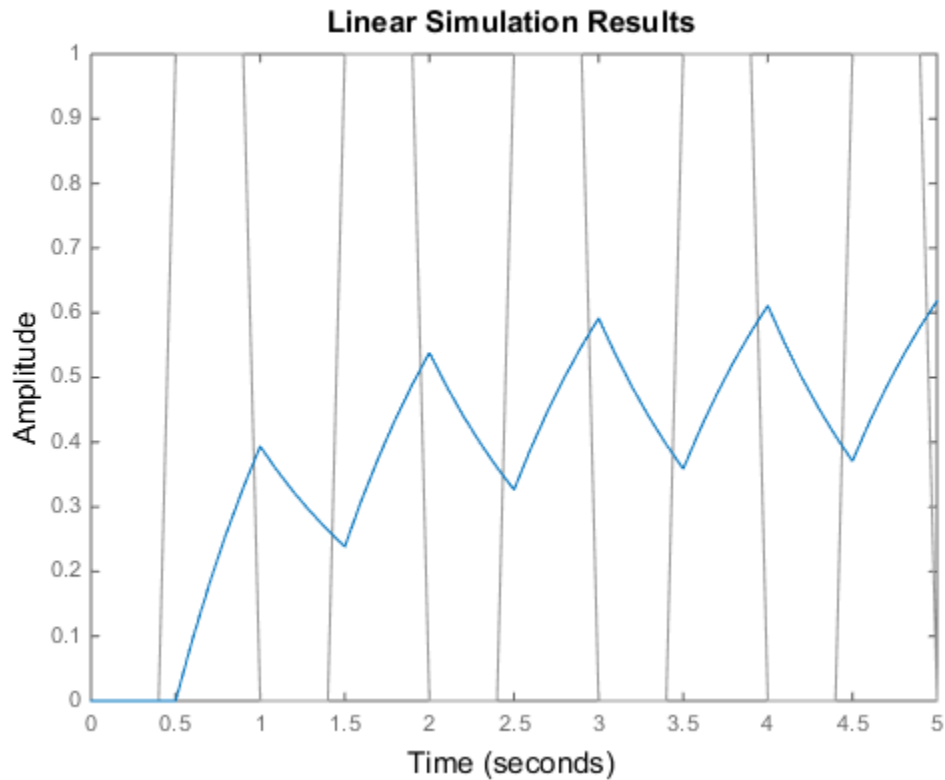
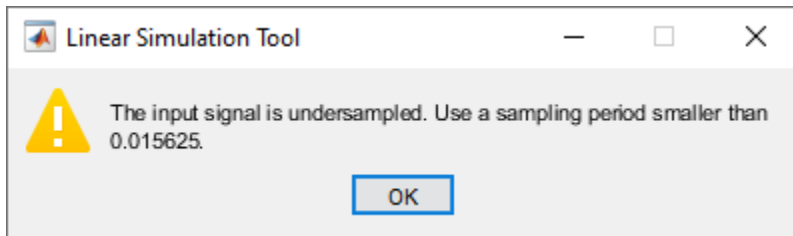

`lsim` simulates the model using the specified input signal, but it issues a warning that the input signal is undersampled. `lsim` recommends a sample time that generates at least 64 samples per period of the input `u`. To see why this recommendation matters, simulate `sys` again using a sample time smaller than the recommended maximum.

```

figure
Ts2 = 0.01;
[u2,t2] = gensig("square",tau,Tf,Ts2);
lsim(sys,u2,t2)

```

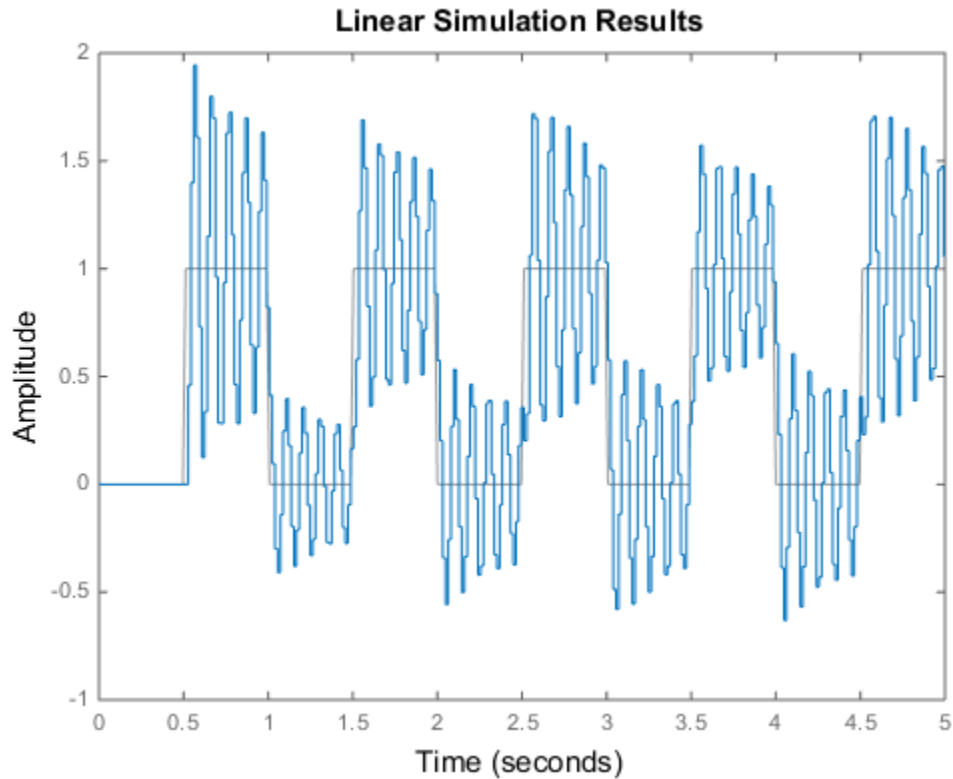

This response exhibits strong oscillatory behavior that is hidden in the undersampled version.

Input Arguments

sys – Dynamic system

dynamic system model | model array

Dynamic system, specified as a SISO or MIMO dynamic system model or array of dynamic system models. Dynamic systems whose responses you can simulate include:

- Continuous-time or discrete-time numeric LTI models, such as `tf`, `zpk`, or `ss` models.
- Generalized or uncertain LTI models such as `genss` or `uss` models. (Using uncertain models requires Robust Control Toolbox software.)
 - For tunable control design blocks, the function evaluates the model at its current value for both plotting and returning response data.
 - For uncertain control design blocks, the function plots the nominal value and random samples of the model. When you use output arguments, the function returns response data for the nominal model only.
- Sparse state-space models such as `sparss` and `mehss` models.
- Identified LTI models, such as `idtf`, `idss`, or `idproc` models. For identified models, you can also use the `sim` command, which can compute the standard deviation of the simulated response and state trajectories. `sim` can also simulate all types of models with nonzero initial conditions, and

can simulate nonlinear identified models. (Using identified models requires System Identification Toolbox software.)

`lsim` does not support frequency-response data models such as `frd`, `genfrd`, or `idfrd` models.

If `sys` is an array of models, the function plots the responses of all models in the array on the same axes. See “Response of Systems in Model Array” on page 2-655.

u — Input signal

vector | array

Input signal for simulation, specified as a vector for single-input systems, and an array for multi-input systems.

- For single-input systems, `u` is a vector of the same length as `t`.
- For multi-input systems, `u` is an array with as many rows as there are time samples (`length(t)`) and as many columns as there are inputs to `sys`. In other words, each row `u(i, :)` represents the values applied at the inputs of `sys` at time `t(i)`. Each column `u(:, j)` is the signal applied to the `j`th input of `sys`.

t — Time samples

vector

Time samples at which to compute the response, specified as a vector of the form `0:dT:Tf`. The `lsim` command interprets `t` as having the units specified in the `TimeUnit` property of the model `sys`.

For continuous-time `sys`, the `lsim` command uses the time step `dT` to discretize the model. If `dT` is too large relative to the system dynamics (undersampling), `lsim` issues a warning recommending a faster sampling time. For further discussion of the impact of sampling time on simulation, see “Effect of Sample Time on Simulation” on page 2-657.

For discrete-time `sys`, the time step `dT` must equal the sample time of `sys`. Alternatively, you can omit `t` or set it to `[]`. In that case, `lsim` sets `t` to a vector of the same length as `u` that begins at 0 with a time step equal to `sys.Ts`.

x0 — Initial state values

vector of zeros (default) | vector

Initial state values for simulating a state-space model, specified as a vector having one entry for each state in `sys`. If you omit this argument, then `lsim` sets all states to zero at `t = 0`.

method — Discretization method

'zoh' | 'foh'

Discretization method for sampling continuous-time models, specified as one of the following.

- 'zoh' — Zero-order hold
- 'foh' — First-order hold

When `sys` is a continuous-time model, `lsim` computes the time response by discretizing the model using a sample time equal to the time step `dT = t(2) - t(1)` of `t`. If you do not specify a discretization method, then `lsim` selects the method automatically based on the smoothness of the signal `u`. For more information about these two discretization methods, see “Continuous-Discrete Conversion Methods”.

LineStyle — Line style, marker, and color

character vector | string

Line style, marker, and color, specified as a string or vector of one, two, or three characters. The characters can appear in any order. You do not need to specify all three characteristics (line style, marker, and color). For example, if you omit the line style and specify the marker, then the plot shows only the marker and no line. For more information about configuring this argument, see the `LineStyle` input argument of the `plot` function.

Example: 'r--' specifies a red dashed line

Example: '*b' specifies blue asterisk markers

Example: 'y' specifies a yellow line

Output Arguments**y — Simulated response data**

array

Simulated response data, returned as an array.

- For single-input systems, `y` is a column vector of the same length as `t`.
- For multi-output systems, `y` is an array with as many rows as there are time samples (`length(t)`) and as many columns as there are outputs in `sys`. Thus, the j th column of `y`, or `y(:,j)`, contains the response at the j th output to `u` applied at all inputs.

tOut — Time vector

vector

Time vector used for simulation, returned as a column vector. When you specify an input time vector `t` of the form `0:dT:Tf`, then `tOut = t`. If `t` is nearly equisampled, `lsim` adjusts the sample times for simulation and returns the result in `tOut`. For discrete-time `sys`, you can omit `t` or set it to `[]`. In that case, `lsim` sets `t` to a vector of the same length as `u` that begins at 0 with a time step equal to `sys.Ts`, and returns the result in `tOut`.

x — State trajectories

array

State trajectories, returned as an array. When `sys` is a state-space model, `x` contains the evolution of the states of `sys` in response to the input. `x` is an array with as many rows as there are time samples (`length(t)`) and as many columns as there are states in `sys`.

Tips

- When you need additional plot customization options, use `lsimplot` instead.

Algorithms

For a discrete-time transfer function,

$$\text{sys}(z^{-1}) = \frac{a_0 + a_1z^{-1} + \dots + a_nz^{-n}}{1 + b_1z^{-1} + \dots + b_nz^{-n}},$$

`lsim` filters the input based on the recursion associated with this transfer function:

$$y[k] = a_0u[k] + \dots + a_nu[k - n] - b_1y[k - 1] - \dots - b_ny[k - n].$$

For discrete-time `zpk` models, `lsim` filters the input through a series of first-order or second-order sections. This approach avoids forming the numerator and denominator polynomials, which can cause numerical instability for higher-order models.

For discrete-time state-space models, `lsim` propagates the discrete-time state-space equations,

$$\begin{aligned}x[n + 1] &= Ax[n] + Bu[n], \\y[n] &= Cx[n] + Du[n].\end{aligned}$$

For continuous-time systems, `lsim` first discretizes the system using `c2d`, and then propagates the resulting discrete-time state-space equations. Unless you specify otherwise with the `method` input argument, `lsim` uses the first-order-hold discretization method when the input signal is smooth, and zero-order hold when the input signal is discontinuous, such as for pulses or square waves. The sample time for discretization is the spacing `dT` between the time samples you supply in `t`.

Version History

Introduced before R2006a

See Also

Functions

`gensig` | `impulse` | `initial` | `step` | `lsiminfo` | `lsimplot`

Apps

Linear System Analyzer

lsiminfo

Compute linear response characteristics

Syntax

```
S = lsiminfo(y,t)
S = lsiminfo(y,t,yfinal)
S = lsiminfo(y,t,yfinal,yinit)

S = lsiminfo(___, 'SettlingTimeThreshold', ST)
```

Description

`lsiminfo` lets you compute linear response characteristics from an array of response data $[y, t]$. For a linear response $y(t)$, `lsiminfo` computes characteristics relative to y_{init} and y_{final} , where y_{init} is the initial offset, that is, the value before the input is applied, and y_{final} is the steady-state value of the response.

`lsiminfo` uses $y_{init} = 0$ and $y_{final} =$ last sample value of $y(t)$ unless you explicitly specify these values.

The function returns the characteristics in a structure containing the fields:

- **TransientTime** — The first time T such that the error $|y(t) - y_{final}| \leq \text{SettlingTimeThreshold} \times e_{max}$ for $t \geq T$, where e_{max} is the maximum error $|y(t) - y_{final}|$ for $t \geq 0$.

By default, *SettlingTimeThreshold* = 0.02 (2% of the peak error). Transient time measures how quickly the transient dynamics die off.

- **SettlingTime** — The first time T such that $|y(t) - y_{final}| \leq \text{SettlingTimeThreshold} \times |y_{final} - y_{init}|$ for $t \geq T$.

By default, settling time measures the time it takes for the error to stay below 2% of $|y_{final} - y_{init}|$.

- **Min** — Minimum value of $y(t)$.
- **MinTime** — Time the response takes to reach the minimum value.
- **Max** — Maximum value of $y(t)$.
- **MaxTime** — Time the response takes to reach the maximum value.

`S = lsiminfo(y, t)` computes linear response characteristics from an array of response data y and corresponding time vector t . This syntax uses $y_{init} = 0$ and the last value in y (or the last value in each channel's corresponding response data) as y_{final} to compute characteristics that depend on these values.

For SISO system responses, y is a vector with the same number of entries as t . For MIMO response data, y is an array containing the responses of each I/O channel.

`S = lsiminfo(y, t, yfinal)` computes linear response characteristics relative to the steady-state value y_{final} . This syntax is useful when you know that the expected steady-state system response differs from the last value in y for reasons such as measurement noise. This syntax uses $y_{init} = 0$.

For SISO responses, `t` and `y` are vectors with the same length `NS`. For systems with `NY` outputs, you can specify `y` as an `NS`-by-`NY` array and `yfinal` as an `NY`-by-1 array. `lsiminfo` then returns a `NY`-by-1 structure array `S` of response characteristics corresponding to each output channel.

`S = lsiminfo(y,t,yfinal,yinit)` computes response characteristics relative to the response initial value `yinit`. This syntax is useful when your `y` data has an initial offset, that is, `y` is nonzero before the input is applied.

For SISO responses, `t` and `y` are vectors with the same length `NS`. For systems with `NY` outputs, you can specify `y` as an `NS`-by-`NY` array and `yfinal` and `yinit` as an `NY`-by-1 arrays. `lsiminfo` then returns a `NY`-by-1 structure array `S` of response characteristics corresponding to each output channel.

`S = lsiminfo(____, 'SettlingTimeThreshold', ST)` lets you specify the threshold `ST` used in definition of settling and transient times. The default value is `ST = 0.02` (2%). You can use this syntax with any of the previous input-argument combinations.

Examples

Compute Response Characteristics of Transfer Function

Create the following continuous-time transfer function:

$$H(s) = \frac{s - 1}{s^3 + 2s^2 + 3s + 4}$$

```
sys = tf([1 -1],[1 2 3 4]);
```

Calculate the impulse response.

```
[y,t] = impulse(sys);
```

`impulse` returns the output response `y` and the time vector `t` used for simulation.

Compute the response characteristics using a final response value of `0`.

```
s = lsiminfo(y,t,0)
```

```
s = struct with fields:
  TransientTime: 22.8700
  SettlingTime: NaN
  Min: -0.4268
  MinTime: 2.0088
  Max: 0.2847
  MaxTime: 4.0733
```

You can plot the impulse response and verify these response characteristics. For example, the time at which the minimum response value (`MinTime`) is reached is approximately 2 seconds.

```
impulse(sys)
```

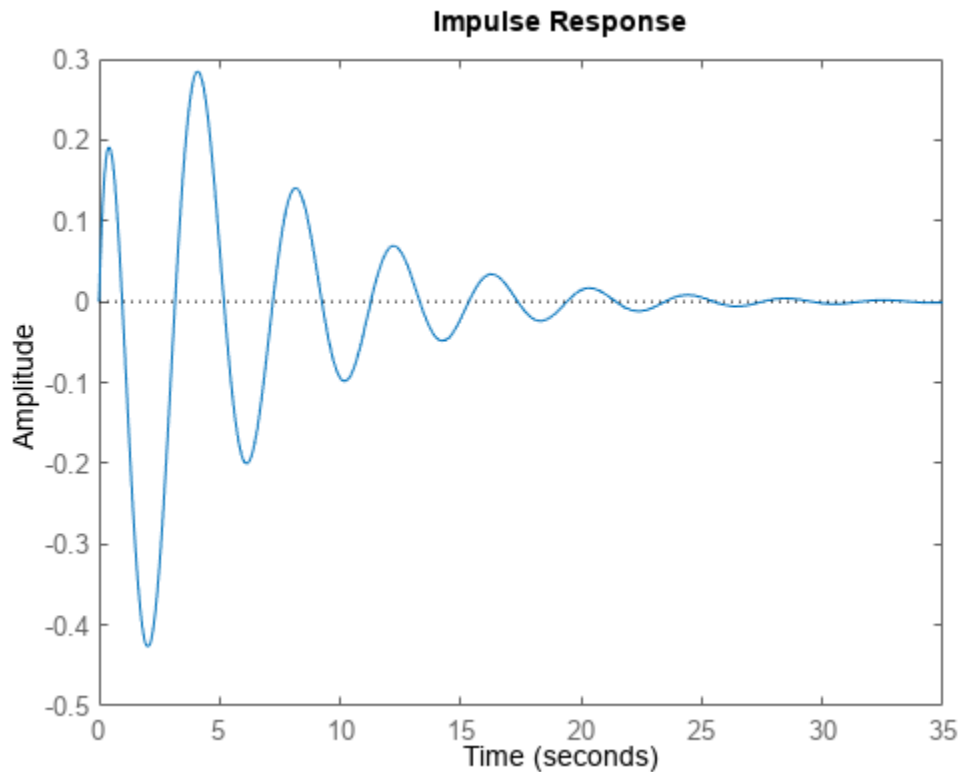

Input Arguments

y — Response data

vector | array

Response data, specified as one of the following:

- For SISO response data, a vector of length N_s , where N_s is the number of samples in the response data.
- For MIMO response data, an N_s -by- N_y array, where N_y is the number of system outputs.

t — Time vector

vector

Time vector corresponding to the response data in **y**, specified as a vector of length N_s .

yfinal — Steady-state value

scalar | array

Response steady-state value, specified as a scalar or an array.

- For SISO response data, specify a scalar value.
- For MIMO response data, specify an N_y -by-1 array, where each entry provides the steady-state response value for the corresponding system channel.

If you do not provide `yfinal`, then `lsiminfo` uses the last value in the corresponding channel of `y` as the steady-state response value.

yinit — Response initial value

scalar | array

Value of `y` before the input is applied, specified as a scalar or an array.

- For SISO response data, specify a scalar value.
- For MIMO response data, specify an N_y -by-1 array, where each entry provides the response initial value for the corresponding system channel.

If you do not provide `yinit`, then `lsiminfo` uses zero as the response initial value.

ST — Settling time threshold

0.02 (default) | scalar between 0 and 1

Threshold for defining settling and transient times, specified as a scalar value between 0 and 1. To change the default settling and transient time definitions (see “Description” on page 2-663), set `ST` to a different value. For instance, to measure when the error falls below 5%, set `ST` to 0.05.

Output Arguments

S — Response characteristics

structure

Linear response characteristics, returned as a structure containing the fields:

- `TransientTime`
- `SettlingTime`
- `Min`
- `MinTime`
- `Max`
- `MaxTime`

For more information on how `lsiminfo` defines these characteristics, see “Description” on page 2-663.

For MIMO models or responses data, `S` is a structure array in which each entry contains the step-response characteristics of the corresponding I/O channel. For instance, if you provide a 3-input, 3-output model or array of response data, then `S(2,3)` contains the characteristics of the response from the third input to the second output.

Version History

Introduced in R2006a

Settling time computation changed

Behavior changed in R2021b

The settling time calculation is now based on the time it takes for the error to stay below 2% of $|y_{final} - y_{init}|$. The following table summarizes the changes to the fields of the structure returned by `lsiminfo`.

Before R2021b	R2021b
<p>SettlingTime — The first time T such that the error $y(t) - y_{final} \leq \text{SettlingTimeThreshold} \times e_{max}$ for $t \geq T$, where e_{max} is the maximum error $y(t) - y_{final}$ for $t \geq 0$.</p> <p>By default, $\text{SettlingTimeThreshold} = 0.02$ (2% of the peak error). SettlingTime measures the time for the error to fall below 2% of the peak value of the error.</p>	<p>SettlingTime — The first time T such that the error $y(t) - y_{final} \leq \text{SettlingTimeThreshold} \times y_{final} - y_{init}$ for $t \geq T$.</p> <p>By default, SettlingTime measures the time it takes for the error to stay below 2% of $y_{final} - y_{init}$.</p>

Additionally, the output structure `S` now contains a `TransientTime` field. This characteristic contains the peak-error-based settling time calculation used in releases before R2021b. Transient time is used to measure how quickly the transient dynamics die off.

See Also

`impulse` | `lsim` | `stepinfo`

lsimplot

Plot simulated time response of dynamic system to arbitrary inputs with additional plot customization options

Syntax

```
h = lsimplot(sys)
h = lsimplot(sys,u,t)
h = lsimplot(sys1,sys2,...,sysN,u,t)
h = lsimplot(sys1,LineStyle1,...,sysN,LineStyleN,u,t)
h = lsimplot( ____,x0)
h = lsimplot( ____,method)
h = lsimplot(AX, ____)
h = lsimplot( ____,plotoptions)
```

Description

`lsimplot` lets you plot simulated time response of dynamic system to arbitrary inputs with a broader range of plot customization options than `lsim`. You can use `lsimplot` to obtain the plot handle and use it to customize the plot, such as modify the axes labels, limits and units. You can also use `lsimplot` to draw a simulated time response plot on an existing set of axes represented by an axes handle. To customize an existing simulated time response plot using the plot handle:

- 1 Obtain the plot handle
- 2 Use `getoptions` to obtain the option set
- 3 Update the plot using `setoptions` to modify the required options

For more information, see “Customizing Response Plots from the Command Line”. To create simulated time response plots with default options or to extract simulated response data, use `lsim`.

`h = lsimplot(sys)` opens the Linear Simulation Tool for the dynamic system model `sys`, where you can interactively specify the driving input(s), the time vector, and initial state. It also returns the plot handle `h`. You can use this handle `h` to customize the plot with the `getoptions` and `setoptions` commands.

For more information about using the Linear Simulation Tool for linear analysis, see [Working with the Linear Simulation Tool](#).

`h = lsimplot(sys,u,t)` plots the simulated time response of the model `sys` to the input signal `u` and the corresponding time vector `t`. For MIMO systems, `u` is a matrix with as many columns as the number of inputs and whose `i`th row specifies the input value at time `t(i)`. For SISO systems, the input `u` can be specified either as a row or column vector.

`h = lsimplot(sys1,sys2,...,sysN,u,t)` plots the simulated response of multiple dynamic systems `sys1,sys2,...,sysN` using the input `u` and time vector `t` on the same plot. All systems must have the same number of inputs and outputs to use this syntax.

`h = lsimplot(sys1,LineStyle1,...,sysN,LineStyleN,u,t)` sets the line style, marker type, and color for the simulated time response of each system. All systems must have the same number of inputs and outputs to use this syntax.

`h = lsimplot(___, x0)` further specifies a vector `x0` of initial state values, when `sys` is a state-space model.

`h = lsimplot(___, method)` specifies how `lsimplot` interpolates the input values between samples, when `sys` is a continuous-time model.

`h = lsimplot(AX, ___)` plots the simulated response on the `Axes` object in the current figure with the handle `AX`.

`h = lsimplot(___, plotoptions)` plots the simulated response with the options set specified in `plotoptions`. You can use these options to customize the plot appearance using the command line. Settings you specify in `plotoptions` overrides the preference settings in the MATLAB session in which you run `lsimplot`. Therefore, this syntax is useful when you want to write a script to generate multiple plots that look the same regardless of the local preferences.

Examples

Customized Plot of Simulated Response to Arbitrary Input Signal

For this example, change time units to minutes and turn the grid on for the simulated response plot. Consider the following transfer function.

```
sys = tf(3,[1 2 3]);
```

To compute the response of this system to an arbitrary input signal, provide `lsimplot` with a vector of the times `t` at which you want to compute the response and a vector `u` containing the corresponding signal values. For instance, plot the system response to a ramping step signal that starts at 0 at time `t = 0`, ramps from 0 at `t = 1` to 1 at `t = 2`, and then holds steady at 1. Define `t` and compute the values of `u`.

```
t = 0:0.04:8;  
u = max(0,min(t-1,1));
```

Use `lsimplot` plot the system response to the signal with a plot handle `h`.

```
h = lsimplot(sys,u,t);
```

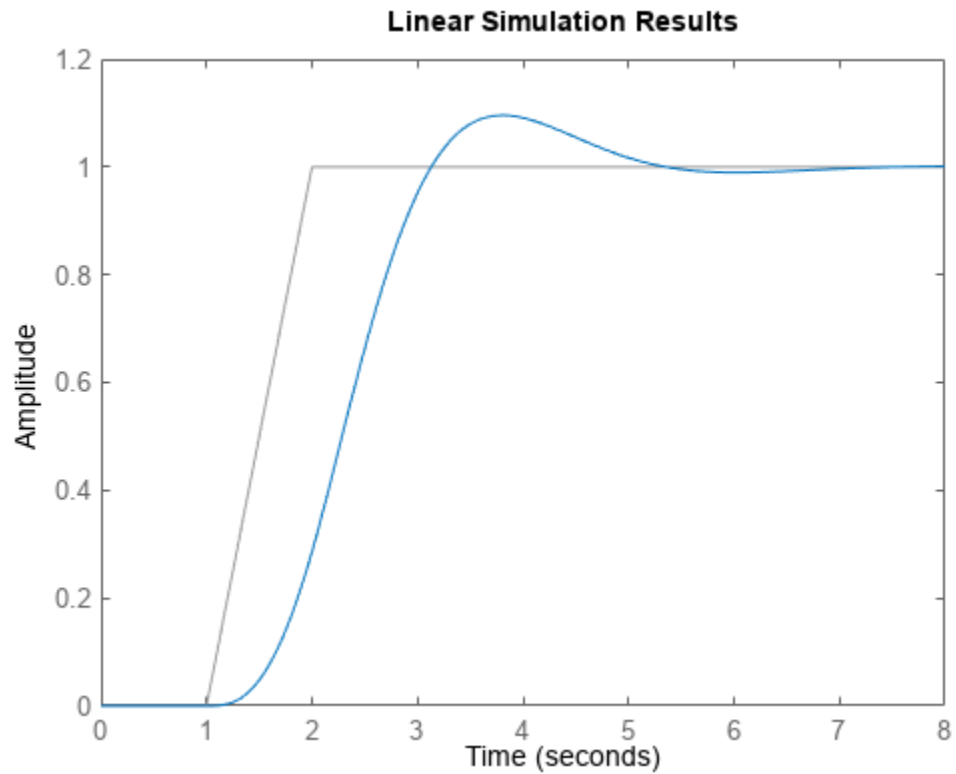

The plot shows the applied input (u, t) in gray and the system response in blue.

Use the plot handle to change the time units to minutes and to turn the grid on. To do so, edit properties of the plot handle, h using `setoptions`.

```
setoptions(h, 'TimeUnits', 'minutes', 'Grid', 'on')
```

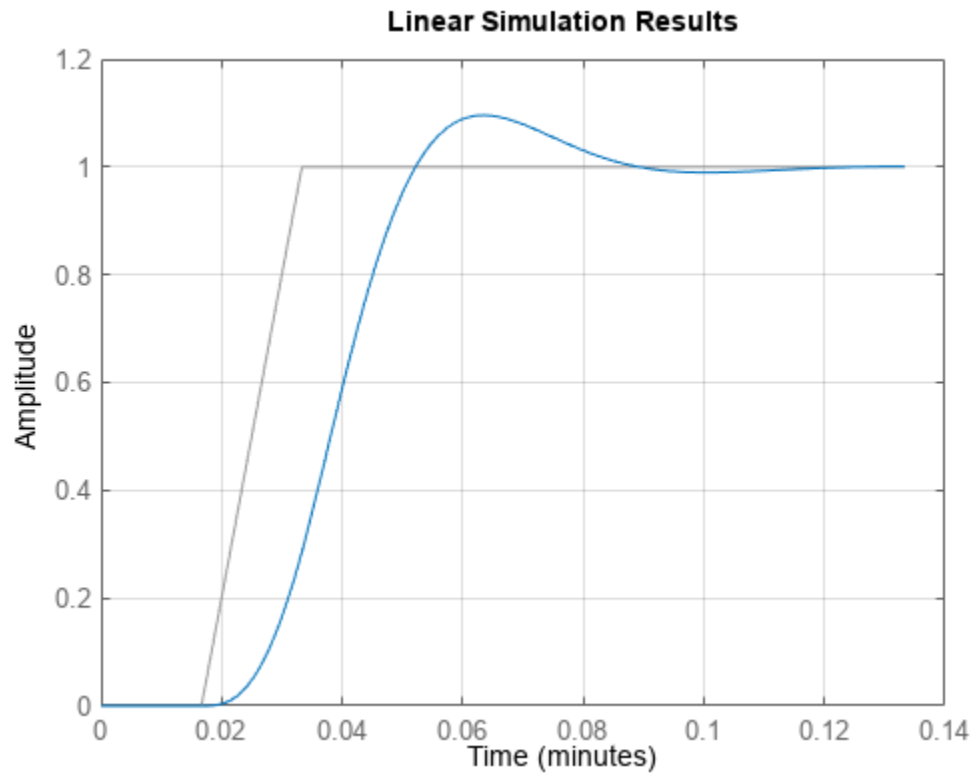
The plot automatically updates when you call `setoptions`.

Alternatively, you can also use the `timeoptions` command to specify the required plot options. First, create an options set based on the toolbox preferences.

```
plotoptions = timeoptions('cstprefs');
```

Change properties of the options set by setting the time units to minutes and enabling the grid.

```
plotoptions.TimeUnits = 'minutes';  
plotoptions.Grid = 'on';  
lsimplot(sys,u,t,plotoptions);
```

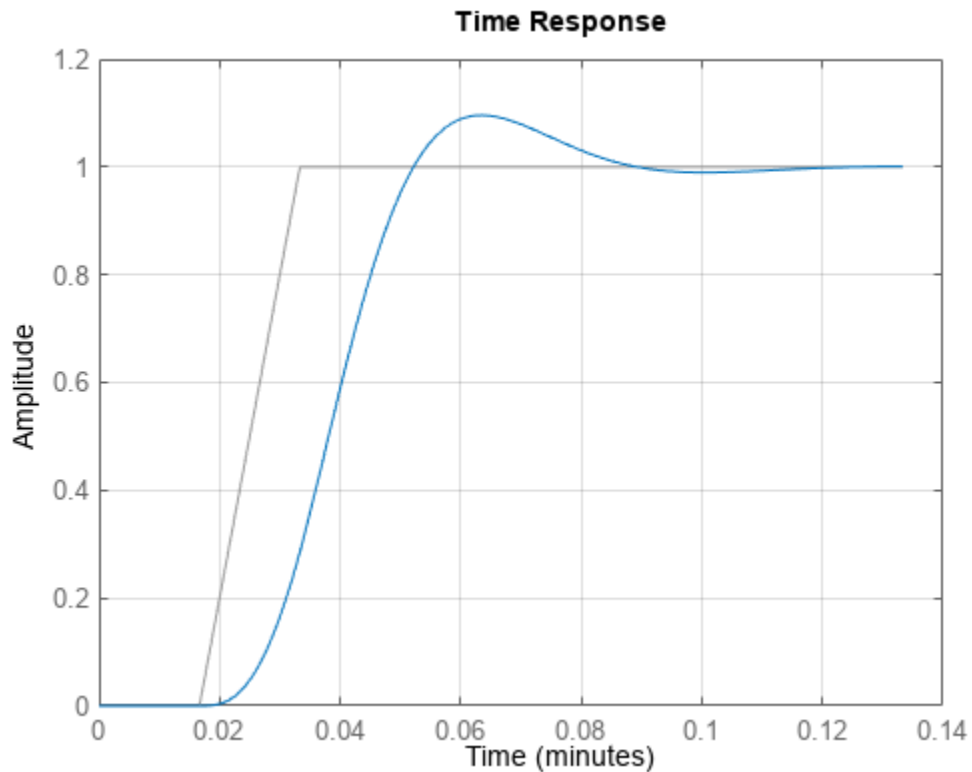

Customized Plot Response of Multiple Systems to Same Input

`lsimplot` allows you to plot the simulated responses of multiple dynamic systems on the same axis. For instance, compare the closed-loop response of a system with a PI controller and a PID controller. Then, customize the plot by enabling normalization and turning the grid on.

First, create a transfer function of the system and tune the controllers.

```
H = tf(4,[1 10 25]);
C1 = pidtune(H,'PI');
C2 = pidtune(H,'PID');
```

Form the closed-loop systems.

```
sys1 = feedback(H*C1,1);
sys2 = feedback(H*C2,1);
```

Plot the responses of both systems to a square wave with a period of 4 s.

```
[u,t] = gensig("square",4,12);
h1 = lsimplot(sys1,sys2,u,t);
legend("PI","PID")
```

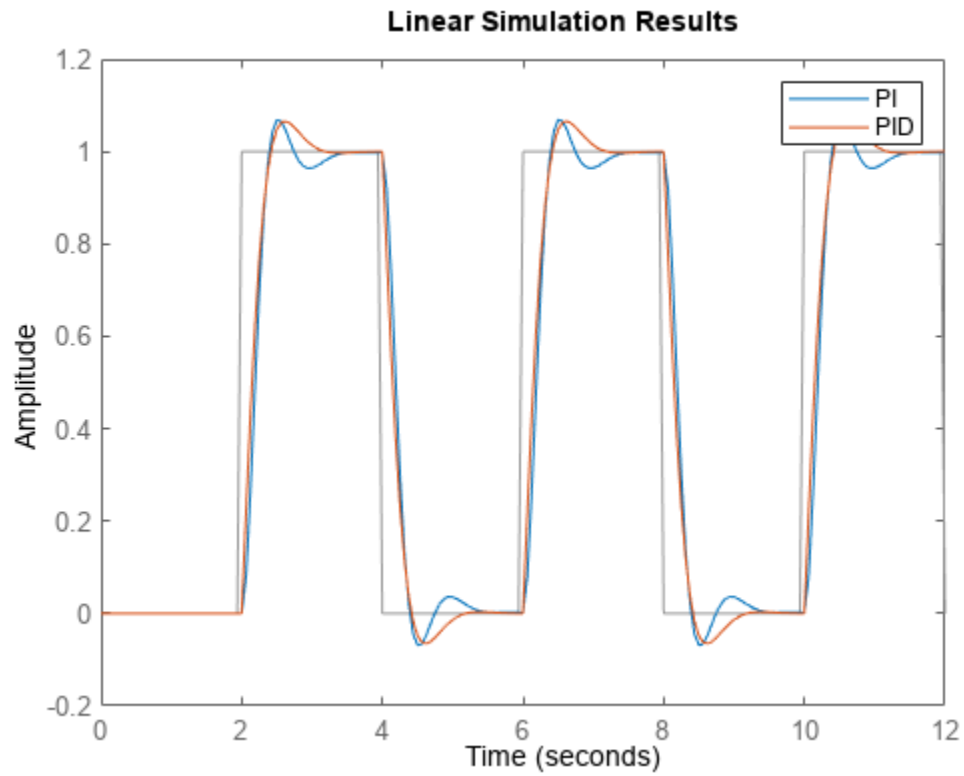

Use setoptions to enable normalization and to turn on the grid.

```
setoptions(h1, 'Normalize', 'on', 'Grid', 'on')
```

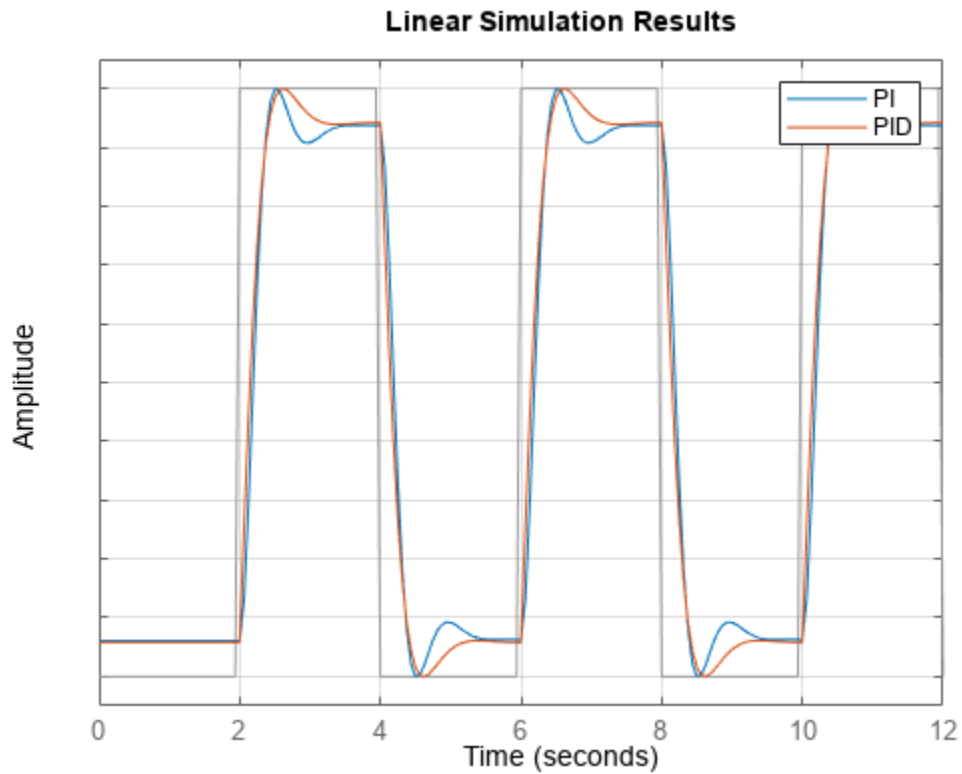

The plot automatically updates when you call `setoptions`.

By default, `lsimplot` chooses distinct colors for each system that you plot. You can specify colors and line styles using the `LineStyle` input argument.

```
h2 = lsimplot(sys1,"r--",sys2,"b",u,t);  
legend("PI","PID")  
setoptions(h2,'Normalize','on','Grid','on')
```

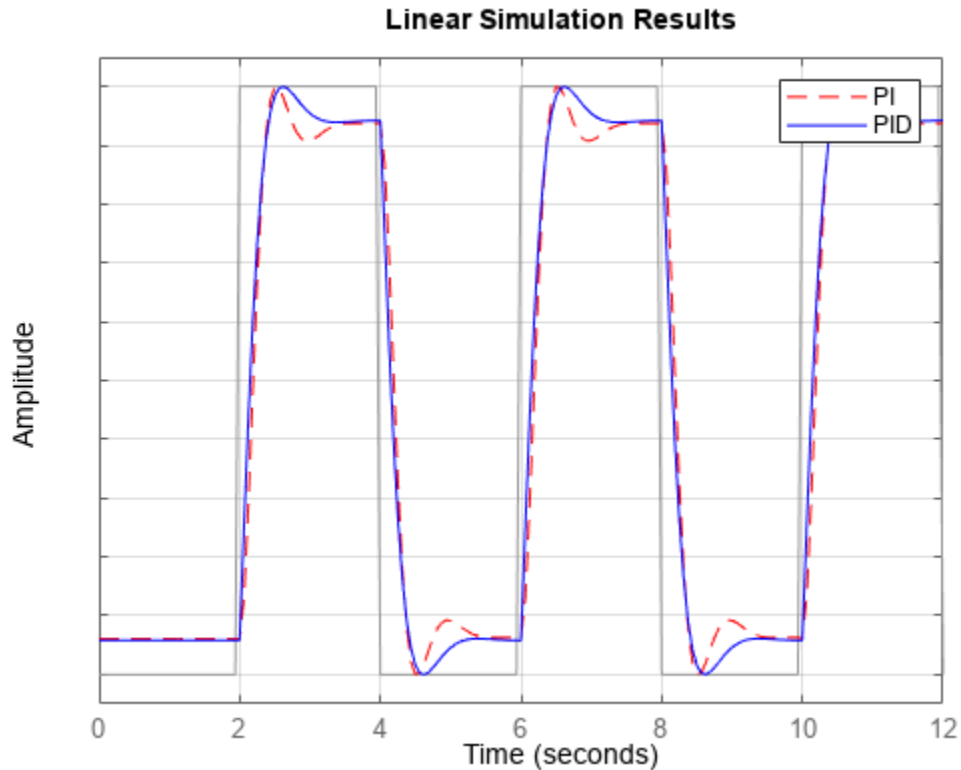

The first LineSpec "r - -" specifies a dashed red line for the response with the PI controller. The second LineSpec "b" specifies a solid blue line for the response with the PID controller. The legend reflects the specified colors and line styles.

Custom Plot of System Evolution from Initial Condition

By default, `lsimplot` simulates the model assuming all states are zero at the start of the simulation. When simulating the response of a state-space model, use the optional `x0` input argument to specify nonzero initial state values. Consider the following two-state SISO state-space model.

```
A = [-1.5 -3;
      3 -1];
B = [1.3; 0];
C = [1.15 2.3];
D = 0;
sys = ss(A,B,C,D);
```

Suppose that you want to allow the system to evolve from a known set of initial states with no input for 2 s, and then apply a unit step change. Specify the vector `x0` of initial state values, and create the input vector.

```
x0 = [-0.2 0.3];
t = 0:0.05:8;
u = zeros(length(t),1);
u(t>=2) = 1;
```

First, create a default options set using `timeoptions`.

```
plotoptions = timeoptions;
```

Next change the required properties of the options set `plotoptions` and plot the simulated response with the zero order hold option.

```
plotoptions.Title.FontSize = 15;
plotoptions.Title.Color = [0 0 1];
plotoptions.Grid = 'on';
h = lsimplot(sys,u,t,x0,plotoptions,'zoh');
hold on
title('Simulated Time Response with Initial Conditions')
```

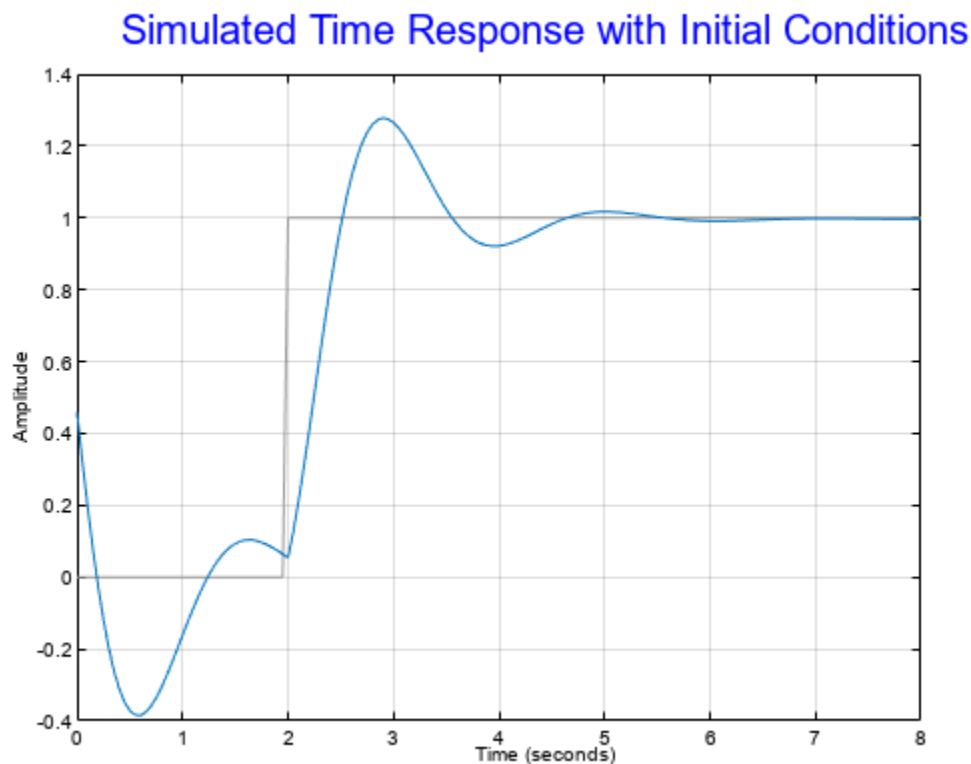

The first half of the plot shows the free evolution of the system from the initial state values $[-0.2 \ 0.3]$. At $t = 2$ there is a step change to the input, and the plot shows the system response to this new signal beginning from the state values at that time. Because `plotoptions` begins with a fixed set of options, the plot result is independent of the toolbox preferences of the MATLAB session.

Input Arguments

sys — Dynamic system

dynamic system model | model array

Dynamic system, specified as a SISO or MIMO dynamic system model or array of dynamic system models. Dynamic systems that you can use include:

- Continuous-time or discrete-time numeric LTI models, such as `tf`, `zpk`, or `ss` models.
- Sparse state-space models, such as `sparss` or `mechss` models. Final time `tFinal` must be specified when using sparse models.
- Generalized or uncertain LTI models such as `genss` or `uss` models. (Using uncertain models requires Robust Control Toolbox software.)
 - For tunable control design blocks, the function evaluates the model at its current value to plot the simulated response.
 - For uncertain control design blocks, the function plots the nominal value and random samples of the model.
- Identified LTI models, such as `idtf`, `idss`, or `idproc` models. For identified models, you can also use the `sim` command, which can compute the standard deviation of the simulated response and state trajectories. `sim` can also simulate all types of models with nonzero initial conditions, and can simulate nonlinear identified models. (Using identified models requires System Identification Toolbox software.)

`lsimplot` does not support frequency-response data models such as `frd`, `genfrd`, or `idfrd` models.

If `sys` is an array of models, the function plots the responses of all models in the array on the same axes.

LineStyle — Line style, marker, and color

character vector | string

Line style, marker, and color, specified as a character vector or string containing symbols. The symbols can appear in any order. You do not need to specify all three characteristics (line style, marker, and color). For example, if you omit the line style and specify the marker, then the plot shows only the marker and no line.

Example: `'- -or'` is a red dashed line with circle markers

Line Style	Description
-	Solid line
- -	Dashed line
:	Dotted line
- .	Dash-dot line

Marker	Description
'o'	Circle
'+'	Plus sign
'*'	Asterisk
'.'	Point
'x'	Cross
'_'	Horizontal line
' '	Vertical line
's'	Square
'd'	Diamond

Marker	Description
'^'	Upward-pointing triangle
'v'	Downward-pointing triangle
'>'	Right-pointing triangle
'<'	Left-pointing triangle
'p'	Pentagram
'h'	Hexagram

Color	Description
y	yellow
m	magenta
c	cyan
r	red
g	green
b	blue
w	white
k	black

u — Input signal for simulation

vector | array

Input signal for simulation, specified as a vector for single-input systems, and an array for multi-input systems.

- For single-input systems, **u** is a vector of the same length as **t**.
- For multi-input systems, **u** is an array with as many rows as there are time samples (`length(t)`) and as many columns as there are inputs to **sys**. In other words, each row `u(i, :)` represents the values applied at the inputs of **sys** at time `t(i)`. Each column `u(:, j)` is the signal applied to the *j*th input of **sys**.

t — Time samples

vector

Time samples at which to compute the response, specified as a vector of the form `0:dT:Tf`. The `lsimplot` command interprets **t** as having the units specified in the `TimeUnit` property of the model **sys**. The time vector must be real, finite, and must contain monotonically increasing and evenly spaced time samples.

For continuous-time systems, the `lsimplot` command uses the time step `dT` to discretize the model. If `dT` is too large relative to the system dynamics (undersampling), `lsimplot` issues a warning recommending a faster sampling time.

For discrete-time systems, the time step `dT` must equal the sample time of **sys**. Alternatively, you can omit **t** or set it to `[]`. In that case, `lsimplot` sets **t** to a vector of the same length as **u** that begins at 0 with a time step equal to `sys.Ts`.

method — Discretization method

'zoh' | 'foh'

Discretization method for sampling continuous-time models, specified as one of the following.

- 'zoh' — Zero-order hold
- 'foh' — First-order hold

When `sys` is a continuous-time model, `lsimplot` computes the time response by discretizing the model using a sample time equal to the time step $dT = t(2) - t(1)$ of `t`. If you do not specify a discretization method, then `lsimplot` selects the method automatically based on the smoothness of the signal `u`. For more information about these two discretization methods, see “Continuous-Discrete Conversion Methods”.

x0 — Initial state values

vector of zeros (default) | vector

Initial state values for simulating a state-space model, specified as a vector having one entry for each state in `sys`. If you omit this argument, then `lsim` sets all states to zero at $t = 0$.

AX — Target axes

Axes object

Target axes, specified as an Axes object. If you do not specify the axes and if the current axes are Cartesian axes, then `stepplot` plots on the current axes. Use `AX` to plot into specific axes when creating a step plot.

plotoptions — Step plot options set

TimePlotOptions object

Step plot options set, specified as a `TimePlotOptions` object. You can use this option set to customize the step plot appearance. Use `timeoptions` to create the option set. Settings you specify in `plotoptions` overrides the preference settings in the MATLAB session in which you run `stepplot`. Therefore, `plotoptions` is useful when you want to write a script to generate multiple plots that look the same regardless of the local preferences.

For the list of available options, see `timeoptions`.

Output Arguments

h — Plot handle

handle object

Plot handle, returned as a `handle` object. Use the handle `h` to get and set the properties of the simulated response plot using `getoptions` and `setoptions`. For the list of available options, see the *Properties and Values Reference* section in “Customizing Response Plots from the Command Line”.

Version History

Introduced before R2006a

See Also

`getoptions` | `setoptions` | `lsim` | `timeoptions`

Topics

“Customizing Response Plots from the Command Line”

“Working with the Linear Simulation Tool”

“Continuous-Discrete Conversion Methods”

looptune

Tune fixed-structure feedback loops

Syntax

```
[G,C,gam] = looptune(G0,C0,wc)
[G,C,gam] = looptune(G0,C0,wc,Req1,...,ReqN)
[G,C,gam] = looptune(...,options)
[G,C,gam,info] = looptune(...)
```

Description

`[G,C,gam] = looptune(G0,C0,wc)` tunes the feedback loop

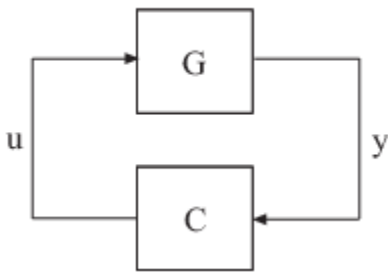

to meet the following default requirements:

- Bandwidth — Gain crossover for each loop falls in the frequency interval wc
- Performance — Integral action at frequencies below wc
- Robustness — Adequate stability margins and gain roll-off at frequencies above wc

The tunable `genss` model `C0` specifies the controller structure, parameters, and initial values. The model `G0` specifies the plant. `G0` can be a Numeric LTI model, or, for co-tuning the plant and controller, a tunable `genss` model. The sensor signals `y` (measurements) and actuator signals `u` (controls) define the boundary between plant and controller.

Note For tuning Simulink models with `looptune`, use `sLTuner` to create an interface to your Simulink model. You can then tune the control system with `looptune` for `sLTuner` (requires Simulink Control Design).

`[G,C,gam] = looptune(G0,C0,wc,Req1,...,ReqN)` tunes the feedback loop to meet additional design requirements specified in one or more tuning goal objects `Req1,...,ReqN`. Omit `wc` to use the requirements specified in `Req1,...,ReqN` instead of an explicit target crossover frequency and the default performance and robustness requirements.

`[G,C,gam] = looptune(...,options)` specifies further options, including target gain margin, target phase margin, and computational options for the tuning algorithm.

`[G,C,gam,info] = looptune(...)` returns a structure `info` with additional information about the tuned result. Use `info` with the `loopview` command to visualize tuning constraints and validate the tuned design.

Input Arguments

G0

Numeric LTI model or tunable `genss` model representing plant in control system to tune.

The plant is the portion of your control system whose outputs are sensor signals (measurements) and whose inputs are actuator signals (controls). Use `connect` to build `G0` from individual numeric or tunable components.

C0

Generalized LTI model representing controller. `C0` specifies the controller structure, parameters, and initial values.

The controller is the portion of your control system that receives sensor signals (measurements) as inputs and produces actuator signals (controls) as outputs. Use Control Design Blocks and Generalized LTI models to represent tunable components of the controller. Use `connect` to build `C0` from individual numeric or tunable components.

wc

Vector specifying target crossover region `[wcmin,wcmax]`. The `looptune` command attempts to tune all loops in the control system so that the open-loop gain crosses 0 dB within the target crossover region.

A scalar `wc` specifies the target crossover region `[wc/2,2*wc]`.

Req1, ..., ReqN

One or more `TuningGoal` objects specifying design requirements, such as `TuningGoal.Tracking`, `TuningGoal.Gain`, or `TuningGoal.LoopShape`.

options

Set of options for `looptune` algorithm, specified using `looptuneOptions`. See `looptuneOptions` for information about the available options, including target gain margin and phase margin.

Output Arguments

G

Tuned plant.

If `G0` is a Numeric LTI model, `G` is the same as `G0`.

If `G0` is a tunable `genss` model, `G` is a `genss` model with Control Design Blocks of the same number and types as `G0`. The current value of `G` is the tuned plant.

C

Tuned controller. `C` is a `genss` model with Control Design Blocks of the same number and types as `C0`. The current value of `C` is the tuned controller.

gam

Parameter indicating degree of success at meeting all tuning constraints. A value of `gam <= 1` indicates that all requirements are satisfied. `gam >> 1` indicates failure to meet at least one requirement. Use `loopview` to visualize the tuned result and identify the unsatisfied requirement.

For best results, use the `RandomStart` option in `looptuneOptions` to obtain several minimization runs. Setting `RandomStart` to an integer `N > 0` causes `looptune` to run the optimization `N` additional times, beginning from parameter values it chooses randomly. You can examine `gam` for each run to help identify an optimization result that meets your design requirements.

info

Data for validating tuning results, returned as a structure. To use the data in `info`, use the command `loopview(G,C,info)` to visualize tuning constraints and validate the tuned design.

`info` contains the following tuning data:

Di, Do

Optimal input and output scalings, returned as state-space models. The scaled plant is given by `Do \G*Di`.

Specs

Design requirements that `looptune` constructs for its call to `system` for tuning (see “Algorithms” on page 2-684), returned as a vector of `TuningGoal` requirement objects.

Runs

Detailed information about each optimization run performed by `system` when called by `looptune` for tuning (see “Algorithms” on page 2-684), returned as a data structure.

The contents of `Runs` are the `info` output of the call to `system`. For information about the fields of `Runs`, see the `info` output argument description on the `system` reference page.

Examples

Tune the control system of the following illustration, to achieve crossover between 0.1 and 1 rad/min.

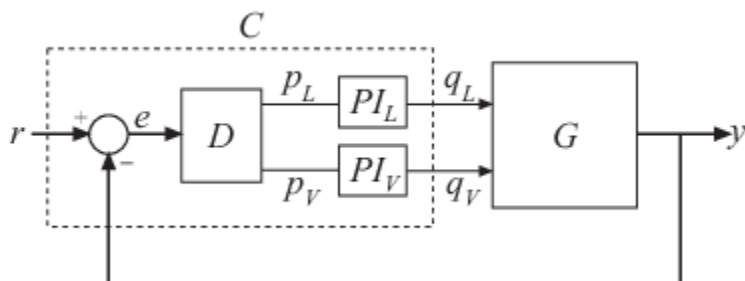

The 2-by-2 plant G is represented by:

$$G(s) = \frac{1}{75s + 1} \begin{bmatrix} 87.8 & -86.4 \\ 108.2 & -109.6 \end{bmatrix}.$$

The fixed-structure controller, C , includes three components: the 2-by-2 decoupling matrix D and two PI controllers PI_L and PI_V . The signals r , y , and e are vector-valued signals of dimension 2.

Build a numeric model that represents the plant and a tunable model that represents the controller. Name all inputs and outputs as in the diagram, so that `looptune` knows how to interconnect the plant and controller via the control and measurement signals.

```
s = tf('s');
G = 1/(75*s+1)*[87.8 -86.4; 108.2 -109.6];
G.InputName = {'qL','qV'};
G.OutputName = 'y';

D = tunableGain('Decoupler',eye(2));
D.InputName = 'e';
D.OutputName = {'pL','pV'};
PI_L = tunablePID('PI_L','pi');
PI_L.InputName = 'pL';
PI_L.OutputName = 'qL';
PI_V = tunablePID('PI_V','pi');
PI_V.InputName = 'pV';
PI_V.OutputName = 'qV';
sum1 = sumblk('e = r - y',2);
C0 = connect(PI_L,PI_V,D,sum1,{'r','y'},{'qL','qV'});

wc = [0.1,1];
[G,C,gam,info] = looptune(G,C0,wc);
```

C is the tuned controller, in this case a `genss` model with the same block types as $C0$.

You can examine the tuned result using `loopview`.

Algorithms

`looptune` automatically converts target bandwidth, performance requirements, and additional design requirements into weighting functions that express the requirements as an H_∞ optimization problem. `looptune` then uses `system` to optimize tunable parameters to minimize the H_∞ norm. For more information about the optimization algorithms, see [1].

`looptune` computes the H_∞ norm using the algorithm of [2] and structure-preserving eigensolvers from the SLICOT library. For more information about the SLICOT library, see <http://slicot.org>.

Alternatives

For tuning Simulink models with `looptune`, see `sITuner` and `looptune` (requires Simulink Control Design).

Version History

Introduced in R2016a

Functionality moved from Robust Control Toolbox

Behavior changed in R2016a

Prior to R2016a, this functionality required a Robust Control Toolbox license.

References

- [1] P. Apkarian and D. Noll, "Nonsmooth H-infinity Synthesis." *IEEE Transactions on Automatic Control*, Vol. 51, Number 1, 2006, pp. 71-86.
- [2] Bruinsma, N.A., and M. Steinbuch. "A Fast Algorithm to Compute the H_{∞} Norm of a Transfer Function Matrix." *Systems & Control Letters*, 14, no.4 (April 1990): 287-93.

Extended Capabilities

Automatic Parallel Support

Accelerate code by automatically running computation in parallel using Parallel Computing Toolbox™.

To run in parallel, set 'UseParallel' to true using `looptuneOptions`.

For more information, see "Speed Up Tuning with Parallel Computing Toolbox Software".

See Also

`TuningGoal.Tracking` | `slTuner` | `systune` | `looptune` (for `slTuner`) | `TuningGoal.Gain` | `TuningGoal.LoopShape` | `hinfstruct` | `looptuneOptions` | `loopview` | `diskmargin` | `genss` | `connect`

Topics

"Tune MIMO Control System for Specified Bandwidth"

"Tune Feedback Loops Using `looptune`"

"Decoupling Controller for a Distillation Column"

looptuneOptions

Set options for looptune

Syntax

```
options = looptuneOptions  
options = looptuneOptions(Name,Value)
```

Description

`options = looptuneOptions` returns the default option set for the `looptune` command.

`options = looptuneOptions(Name,Value)` creates an option set with the options specified by one or more `Name,Value` pair arguments.

Input Arguments

Name-Value Pair Arguments

Specify optional pairs of arguments as `Name1=Value1, . . . ,NameN=ValueN`, where `Name` is the argument name and `Value` is the corresponding value. Name-value arguments must appear after other arguments, but the order of the pairs does not matter.

Before R2021a, use commas to separate each name and value, and enclose Name in quotes.

`looptuneOptions` takes the following `Name` arguments:

GainMargin

Target gain margin in decibels. `GainMargin` specifies the required gain margin for the tuned control system. For MIMO control systems, the gain margin is the multiloop disk margin. See “Stability Analysis Using Disk Margins” (Robust Control Toolbox) for the definition of the multiloop disk margin.

Default: 7.6 dB

PhaseMargin

Target phase margin in degrees. `PhaseMargin` specifies the required phase margin for the tuned control system. For MIMO control systems, the phase margin is the multiloop disk margin. See “Stability Analysis Using Disk Margins” (Robust Control Toolbox) for the definition of the multiloop disk margin.

Default: 45 degrees

Display

Amount of information to display during `looptune` runs, specified as one of the following values.

- `'off'` — Run in silent mode, displaying no information during or after the run.

- `'iter'` — Display optimization progress after each iteration. The display includes the value of the objective parameter `gam` after each iteration. The display also includes a `Progress` value, indicating the percent change in `gam` from the previous iteration.
- `'final'` — Display a one-line summary at the end of each optimization run. The display includes the minimized value of `gam` and the number of iterations for each run.

Default: `'final'`

MaxIter

Maximum number of iterations in each optimization run.

Default: 300

RandomStart

Number of additional optimizations starting from random values of the free parameters in the controller.

If `RandomStart = 0`, `looptune` performs a single optimization run starting from the initial values of the tunable parameters. Setting `RandomStart = N > 0` runs `N` additional optimizations starting from `N` randomly generated parameter values.

`looptune` tunes by finding a local minimum of a gain minimization problem. To increase the likelihood of finding parameter values that meet your design requirements, set `RandomStart > 0`. You can then use the best design that results from the multiple optimization runs.

Use with `UseParallel = true` to distribute independent optimization runs among MATLAB workers (requires Parallel Computing Toolbox™ software).

Default: 0

UseParallel

Parallel processing flag.

When you use the `RandomStart` option to run multiple randomized optimization starts, you can also use parallel computing to speed up tuning by distributing the optimization runs among workers in a parallel pool. Set this flag to `true` to enable parallel processing. If there is an available parallel pool, then the software performs independent optimization runs concurrently among workers in that pool. If no parallel pool is available, one of the following occurs:

- If **Automatically create a parallel pool** is selected in your Parallel Computing Toolbox preferences (Parallel Computing Toolbox), then the software starts a parallel pool using the settings in those preferences.
- If **Automatically create a parallel pool** is not selected in your preferences, then the software performs the optimization runs successively, without parallel processing.

If **Automatically create a parallel pool** is not selected in your preferences, you can manually start a parallel pool using `parpool` before running the tuning command.

Using parallel processing requires Parallel Computing Toolbox software.

Default: `false`

TargetGain

Target value for the objective parameter `gam`.

The `looptune` command converts your design requirements into normalized gain constraints. The command then tunes the free parameters of the control system to drive the objective parameter `gam` below 1 to enforce all requirements.

The default `TargetGain = 1` ensures that the optimization stops as soon as `gam` falls below 1. Set `TargetGain` to a smaller or larger value to continue the optimization or start sooner, respectively.

Default: 1

TolGain

Relative tolerance for termination.

The optimization terminates when the objective parameter `gam` decreases by less than `TolGain` over 10 consecutive iterations. Increasing `TolGain` speeds up termination, and decreasing `TolGain` yields tighter final values.

Default: 0.001

MaxFrequency

Maximum closed-loop natural frequency.

Setting `MaxFrequency` constrains the closed-loop poles to satisfy $|p| < \text{MaxFrequency}$.

To allow `looptune` to choose the closed-loop poles automatically, based upon the system's open-loop dynamics, set `MaxFrequency = Inf`. To prevent unwanted fast dynamics or high-gain control, set `MaxFrequency` to a finite value.

Specify `MaxFrequency` in units of `1/TimeUnit`, relative to the `TimeUnit` property of the system you are tuning.

Default: `Inf`

MinDecay

Minimum decay rate for closed-loop poles

Constrains the closed-loop poles to satisfy $\text{Re}(p) < -\text{MinDecay}$. Increase this value to improve the stability of closed-loop poles that do not affect the closed-loop gain due to pole/zero cancellations.

Specify `MinDecay` in units of `1/TimeUnit`, relative to the `TimeUnit` property of the system you are tuning.

Default: `1e-7`

Output Arguments**options**

Option set containing the specified options for the `looptune` command.

Examples

Create Options Set for looptune

Create an options set for a looptune run using three random restarts. Also, set the target gain and phase margins to 6 dB and 50 degrees, respectively, and limit the closed-loop pole magnitude to 100.

```
options = looptuneOptions('RandomStart',3,'GainMargin',6,...
    'PhaseMargin',50,'SpecRadius',100);
```

Alternatively, use dot notation to set the values of options.

```
options = looptuneOptions;
options.RandomStart = 3;
options.GainMargin = 6;
options.PhaseMargin = 50;
options.SpecRadius = 100;
```

Configure Option Set for Parallel Optimization Runs

Configure an option set for a looptune run using 20 random restarts. Execute these independent optimization runs concurrently on multiple workers in a parallel pool.

If you have the Parallel Computing Toolbox software installed, you can use parallel computing to speed up looptune tuning of fixed-structure control systems. When you run multiple randomized looptune optimization starts, parallel computing speeds up tuning by distributing the optimization runs among workers.

If **Automatically create a parallel pool** is not selected in your Parallel Computing Toolbox preferences (Parallel Computing Toolbox), manually start a parallel pool using `parpool`. For example:

```
parpool;
```

If **Automatically create a parallel pool** is selected in your preferences, you do not need to manually start a pool.

Create a looptuneOptions set that specifies 20 random restarts to run in parallel.

```
options = looptuneOptions('RandomStart',20,'UseParallel',true);
```

Setting `UseParallel` to `true` enables parallel processing by distributing the randomized starts among available workers in the parallel pool.

Use the looptuneOptions set when you call looptune. For example, suppose you have already created a plant model `G0` and tunable controller `C0`. In this case, the following command uses parallel computing to tune the control system of `G0` and `C0` to the target crossover `wc`.

```
[G,C,gamma] = looptune(G0,C0,wc,options);
```

Version History

Introduced in R2016a

Functionality moved from Robust Control Toolbox

Behavior changed in R2016a

Prior to R2016a, this functionality required a Robust Control Toolbox license.

See Also

`looptune` | `looptune (for sITuner)` | `diskmargin`

Topics

“Stability Analysis Using Disk Margins” (Robust Control Toolbox)

looptuneSetup

Convert tuning setup for looptune to tuning setup for systune

Syntax

```
[T0,SoftReqs,HardReqs,sysopt] = looptuneSetup(looptuneInputs)
```

Description

`[T0,SoftReqs,HardReqs,sysopt] = looptuneSetup(looptuneInputs)` converts a tuning setup for looptune into an equivalent tuning setup for systune. The argument `looptuneInputs` is a sequence of input arguments for looptune that specifies the tuning setup. For example,

```
[T0,SoftReqs,HardReqs,sysopt] = looptuneSetup(G0,C0,wc,Req1,Req2,loopopt)
```

generates a set of arguments such that `looptune(G0,C0,wc,Req1,Req2,loopopt)` and `systune(T0,SoftReqs,HardReqs,sysopt)` produce the same results.

Use this command to take advantage of additional flexibility that `systune` offers relative to `looptune`. For example, `looptune` requires that you tune all channels of a MIMO feedback loop to the same target bandwidth. Converting to `systune` allows you to specify different crossover frequencies and loop shapes for each loop in your control system. Also, `looptune` treats all tuning requirements as soft requirements, optimizing them but not requiring that any constraint be exactly met. Converting to `systune` allows you to enforce some tuning requirements as hard constraints, while treating others as soft requirements.

You can also use this command to probe into the tuning requirements used by `looptune`.

Note When tuning Simulink models through an `sLTuner` interface, use `looptuneSetup` for `sLTuner`.

Examples

Convert looptune Problem into systune Problem

Convert a set of looptune inputs into an equivalent set of inputs for systune.

Suppose you have a numeric plant model, `G0`, and a tunable controller model, `C0`. Suppose also that you used `looptune` to tune the feedback loop between `G0` and `C0` to within a bandwidth of `wc = [wmin,wmax]`. Convert these variables into a form that allows you to use `systune` for further tuning.

```
[T0,SoftReqs,HardReqs,sysopt] = looptuneSetup(C0,G0,wc);
```

The command returns the closed-loop system and tuning requirements for the equivalent `systune` command, `systune(CL0,SoftReqs,HardReqs,sysopt)`. The arrays `SoftReqs` and `HardReqs` contain the tuning requirements implicitly imposed by `looptune`. These requirements enforce the target bandwidth and default stability margins of `looptune`.

If you used additional tuning requirements when tuning the system with `looptune`, add them to the input list of `looptuneSetup`. For example, suppose you used a `TuningGoal.Tracking` requirement, `Req1`, and a `TuningGoal.Rejection` requirement, `Req2`. Suppose also that you set algorithm options for `looptune` using `looptuneOptions`. Incorporate these requirements and options into the equivalent `systeme` command.

```
[T0,SoftReqs,HardReqs,sysopt] = looptuneSetup(C0,G0,wc,Req1,Req2,loopopt);
```

The resulting arguments allow you to construct an equivalent tuning problem for `systeme`. In particular, `[~,C] = looptune(C0,G0,wc,Req1,Req2,loopopt)` yields the same result as the following commands.

```
T = systeme(T0,SoftReqs,HardReqs,sysopt);
C = setBlockValue(C0,T);
```

Convert Distillation Column Problem for Tuning With `systeme`

Set up the following control system for tuning with `looptune`. Then convert the setup to a `systeme` problem and examine the results. These results reflect the structure of the control system model that `looptune` tunes. The results also reflect the tuning requirements implicitly enforced when tuning with `looptune`.

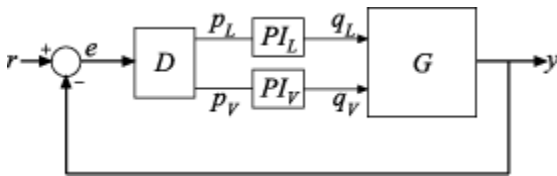

For this example, the 2-by-2 plant `G` is represented by:

$$G(s) = \frac{1}{75s + 1} \begin{bmatrix} 87.8 & -86.4 \\ 108.2 & -109.6 \end{bmatrix}.$$

The fixed-structure controller, `C`, includes three components: the 2-by-2 decoupling matrix `D` and two PI controllers `PI_L` and `PI_V`. The signals `r`, `y`, and `e` are vector-valued signals of dimension 2.

Build a numeric model that represents the plant and a tunable model that represents the controller. Name all inputs and outputs as in the diagram, so that `looptune` and `looptuneSetup` know how to interconnect the plant and controller via the control and measurement signals.

```
s = tf('s');
G = 1/(75*s+1)*[87.8 -86.4; 108.2 -109.6];
G.InputName = {'qL','qV'};
G.OutputName = {'y'};

D = tunableGain('Decoupler',eye(2));
D.InputName = 'e';
D.OutputName = {'pL','pV'};
PI_L = tunablePID('PI_L','pi');
PI_L.InputName = 'pL';
PI_L.OutputName = 'qL';
PI_V = tunablePID('PI_V','pi');
PI_V.InputName = 'pV';
PI_V.OutputName = 'qV';
```

```
sum1 = sumblk('e = r - y',2);
C0 = connect(PI_L,PI_V,D,sum1,{'r','y'},{'qL','qV'});
```

This system is now ready for tuning with `looptune`, using tuning goals that you specify. For example, specify a target bandwidth range. Create a tuning requirement that imposes reference tracking in both channels of the system with a response time of 15 s, and a disturbance rejection requirement.

```
wc = [0.1,0.5];
TR = TuningGoal.Tracking('r','y',15,0.001,1);
DR = TuningGoal.Rejection({'qL','qV'},1/s);
DR.Focus = [0 0.1];
```

```
[G,C,gam,info] = looptune(G,C0,wc,TR,DR);
```

```
Final: Peak gain = 1, Iterations = 42
Achieved target gain value TargetGain=1.
```

`looptune` successfully tunes the system to these requirements. However, you might want to switch to `systune` to take advantage of additional flexibility in configuring your problem. For example, instead of tuning both channels to a loop bandwidth inside `wc`, you might want to specify different crossover frequencies for each loop. Or, you might want to enforce the tuning requirements `TR` and `DR` as hard constraints, and add other requirements as soft requirements.

Convert the `looptune` input arguments to a set of input arguments for `systune`.

```
[T0,SoftReqs,HardReqs,sysopt] = looptuneSetup(G,C0,wc,TR,DR);
```

This command returns a set of arguments you can provide to `systune` for equivalent results to tuning with `looptune`. In other words, the following command is equivalent to the previous `looptune` command.

```
[T,fsoft,ghard,info] = systune(T0,SoftReqs,HardReqs,sysopt);
```

```
Final: Peak gain = 1, Iterations = 42
Achieved target gain value TargetGain=1.
```

Examine the arguments returned by `looptuneSetup`.

```
T0
```

```
T0 =
```

```
Generalized continuous-time state-space model with 0 outputs, 2 inputs, 4 states, and the following blocks:
  APU_: Analysis point, 2 channels, 1 occurrences.
  APY_: Analysis point, 2 channels, 1 occurrences.
  Decoupler: Tunable 2x2 gain, 1 occurrences.
  PI_L: Tunable PID controller, 1 occurrences.
  PI_V: Tunable PID controller, 1 occurrences.
```

Type `"ss(T0)"` to see the current value, `"get(T0)"` to see all properties, and `"T0.Blocks"` to interact with the blocks.

The software constructs the closed-loop control system for `systune` by connecting the plant and controller at their control and measurement signals, and inserting a two-channel `AnalysisPoint` block at each of the connection locations, as illustrated in the following diagram.

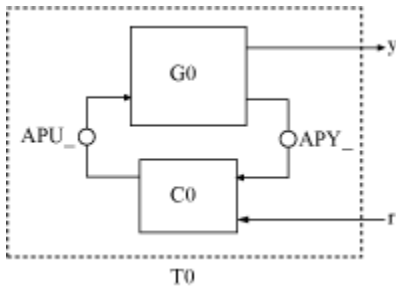

When tuning the control system of this example with `looptune`, all requirements are treated as soft requirements. Therefore, `HardReqs` is empty. `SoftReqs` is an array of `TuningGoal` requirements. These requirements together enforce the bandwidth and margins of the `looptune` command, plus the additional requirements that you specified.

`SoftReqs`

```
SoftReqs=5x1 object
```

```
5x1 heterogeneous SystemLevel (LoopShape, Tracking, Rejection, ...) array with properties:
```

```
Models
Openings
Name
```

Examine the first entry in `SoftReqs`.

```
SoftReqs(1)
```

```
ans =
  LoopShape with properties:
    LoopGain: [1x1 zpk]
    CrossTol: 0.3495
    Focus: [0 Inf]
    Stabilize: 1
    LoopScaling: 'on'
    Location: {2x1 cell}
    Models: NaN
    Openings: {0x1 cell}
    Name: 'Open loop CG'
```

`looptuneSetup` expresses the target crossover frequency range `wc` as a `TuningGoal.LoopShape` requirement. This requirement constrains the open-loop gain profile to the loop shape stored in the `LoopGain` property, with a crossover frequency and crossover tolerance (`CrossTol`) determined by `wc`. Examine this loop shape.

```
viewGoal(SoftReqs(1))
```

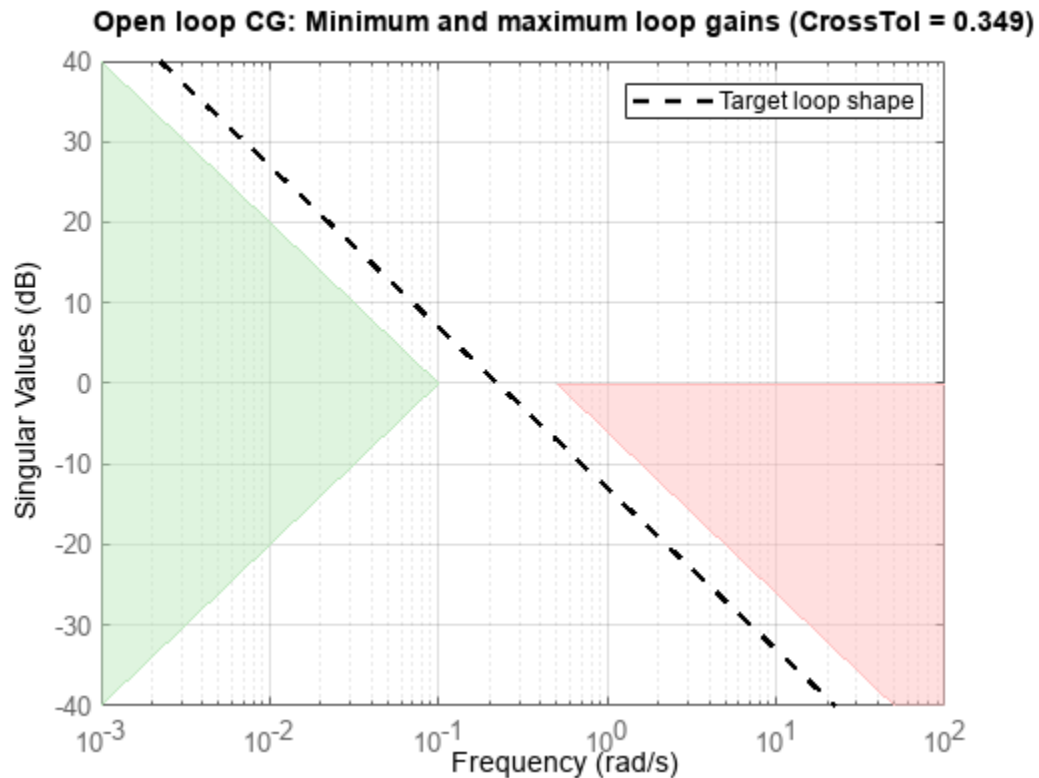
The target crossover is expressed as an integrator gain profile with a crossover between 0.1 and 0.5 rad/s, as specified by `wc`. If you want to specify a different loop shape, you can alter this `TuningGoal.LoopShape` requirement before providing it to `systeme`.

`looptune` also tunes to default stability margins that you can change using `looptuneOptions`. For `systeme`, stability margins are specified using `TuningGoal.Margins` requirements. Here, `looptuneSetup` has expressed the default stability margins of `looptune` as soft `TuningGoal.Margins` requirements. For example, examine the fourth entry in `SoftReqs`.

`SoftReqs(4)`

```
ans =
  Margins with properties:
    GainMargin: 7.6000
    PhaseMargin: 45
    ScalingOrder: 0
    Focus: [0 Inf]
    Location: {2x1 cell}
    Models: NaN
    Openings: {0x1 cell}
    Name: 'Margins at plant inputs'
```

The last entry in `SoftReqs` is a similar `TuningGoal.Margins` requirement constraining the margins at the plant outputs. `looptune` enforces these margins as soft requirements. If you want to convert

them to hard constraints, pass them to `systemtune` in the input vector `HardReqs` instead of the input vector `SoftReqs`.

Input Arguments

`looptuneInputs` — Plant, controller, and requirement inputs to `looptune`

valid `looptune` input sequence

Plant, controller, and requirement inputs to `looptune`, specified as a valid `looptune` input sequence. For more information about the arguments in a valid `looptune` input sequence, see the `looptune` reference page.

Output Arguments

`T0` — Closed-loop control system model

generalized state-space model

Closed-loop control system model for tuning with `systemtune`, returned as a generalized state-space `genss` model. To compute `T0`, the plant, `G0`, and the controller, `C0`, are combined in the feedback configuration of the following illustration.

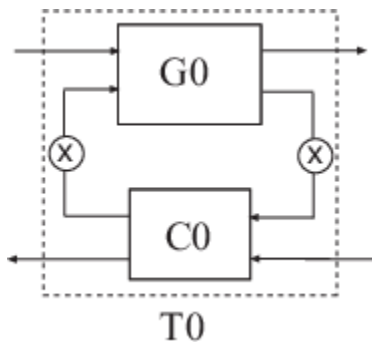

The connections between `C0` and `G0` are determined by matching signals using the `InputName` and `OutputName` properties of the two models. In general, the signal lines in the diagram can represent vector-valued signals. `AnalysisPoint` blocks, indicated by `X` in the diagram, are inserted between the controller and the plant. This allows definition of open-loop and closed-loop requirements on signals injected or measured at the plant inputs or outputs. For example, the bandwidth `wc` is converted into a `TuningGoal.LoopShape` requirement that imposes the desired crossover on the open-loop signal measured at the plant input.

For more information on the structure of closed-loop control system models for tuning with `systemtune`, see the `systemtune` reference page.

`SoftReqs` — Soft tuning requirements

vector of `TuningGoal` requirement objects

Soft tuning requirements for tuning with `systemtune`, specified as a vector of `TuningGoal` requirement objects.

`looptune` expresses most of its implicit tuning requirements as soft tuning requirements. For example, a specified target loop bandwidth is expressed as a `TuningGoal.LoopShape` requirement

with integral gain profile and crossover at the target frequency. Additionally, `looptune` treats all of the explicit requirements you specify (`Req1`, . . . `ReqN`) as soft requirements. `SoftReqs` contains all of these tuning requirements.

HardReqs — Hard tuning requirements

vector of `TuningGoal` requirement objects

Hard tuning requirements (constraints) for tuning with `sysune`, specified as a vector of `TuningGoal` requirement objects.

Because `looptune` treats most tuning requirements as soft requirements, `HardReqs` is usually empty. However, if you change the default `MaxFrequency` option of the `looptuneOptions` set, `loopopt`, then this requirement appears as a hard `TuningGoal.Poles` constraint.

sysopt — Algorithm options for `sysune` tuning

`sysuneOptions` options set

Algorithm options for `sysune` tuning, specified as a `sysuneOptions` options set.

Some of the options in the `looptuneOptions` set, `loopopt`, are expressed as hard or soft requirements that are returned in `HardReqs` and `SoftReqs`. Other options correspond to options in the `sysuneOptions` set.

Alternatives

When tuning Simulink using an `sLTuner` interface, convert a `looptune` problem to `sysune` using `looptuneSetup` for `sLTuner`.

Version History

Introduced in R2013b

See Also

`looptune` | `sysune` | `looptuneOptions` | `sysuneOptions` | `genss` | `sLTuner` | `looptuneSetup` (for `sLTuner`)

loopview

Graphically analyze MIMO feedback loops

Syntax

```
loopview(G,C)
loopview(G,C,info)
```

Description

`loopview(G,C)` plots characteristics of the following positive-feedback, multi-input, multi-output (MIMO) feedback loop with plant G and controller C .

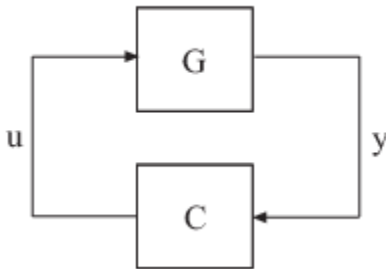

Use `loopview` to analyze the performance of a tuned control system you obtain using `looptune`.

Note If you are tuning a Simulink model with `looptune` through an `sITuner` interface, analyze the performance of your control system using `loopview` for `sITuner` (requires Simulink Control Design).

`loopview` plots the singular values of:

- Open-loop frequency responses $G*C$ and $C*G$
- Sensitivity function $S = \text{inv}(1-G*C)$ and complementary sensitivity $T = 1-S$
- Maximum (target), actual (tuned), and normalized MIMO stability margins. `loopview` plots the multi-loop disk margin (see “Stability Analysis Using Disk Margins” (Robust Control Toolbox)). Use this plot to verify that the stability margins of the tuned system do not significantly exceed the target value.

For more information about singular values, see `sigma`.

`loopview(G,C,info)` uses the `info` structure returned by `looptune`. This syntax also plots the target and tuned values of tuning constraints imposed on the system. Additional plots include:

- Singular values of the maximum allowed S and T . The curve marked S/T Max shows the maximum allowed S on the low-frequency side of the plot, and the maximum allowed T on the high-frequency side. These curves are the constraints that `looptune` imposes on S and T to enforce the target crossover range w_c .

- Target and tuned values of constraints imposed by any tuning goal requirements you used with `looptune`.

Use `loopview` with the `info` structure to assist in troubleshooting when tuning fails to meet all requirements.

Input Arguments

G

Numeric LTI model or tunable `genss` model representing the plant in a control system. The plant is the portion of a control system whose outputs are sensor signals (measurements), and whose inputs are actuator signals (controls).

You can obtain `G` as an output argument from `looptune` when you tune your control system.

C

`genss` model representing the controller in a control system. The controller is the portion of your control system that receives sensor signals (measurements) as inputs and produces actuator signals (controls) as outputs.

You can obtain `C` as an output argument from `looptune` when you tune your control system.

info

`info` structure returned by `looptune` during control system tuning.

Examples

Examine Performance of Tuned Controller

Tune a control system with `looptune` and use `loopview` to examine the performance of the tuned controller.

Create and tune control system.

```
s = tf('s');
G = 1/(75*s+1)*[87.8 -86.4; 108.2 -109.6];
G.InputName = {'qL','qV'};
G.OutputName = 'y';

D = tunableGain('Decoupler',eye(2));
PI_L = tunablePID('PI_L','pi');
PI_L.OutputName = 'qL';
PI_V = tunablePID('PI_V','pi');
PI_V.OutputName = 'qV';

sum = sumblk('e = r - y',2);
C0 = (blkdiag(PI_L,PI_V)*D)*sum;

wc = [0.1,1];
options = looptuneOptions('RandomStart',5);
[G,C,gam,info] = looptune(-G,C0,wc,options);
```

Final: Peak gain = 0.956, Iterations = 28
Achieved target gain value TargetGain=1.

Examine the controller performance.

```
figure('Position',[100,100,520,1000])  
loopview(G,C,info)
```

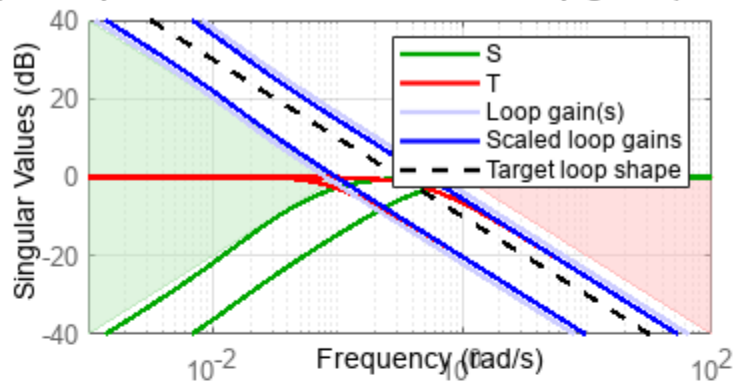
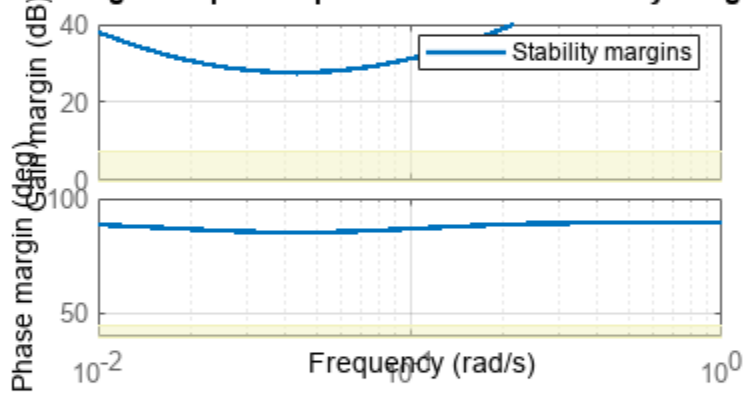
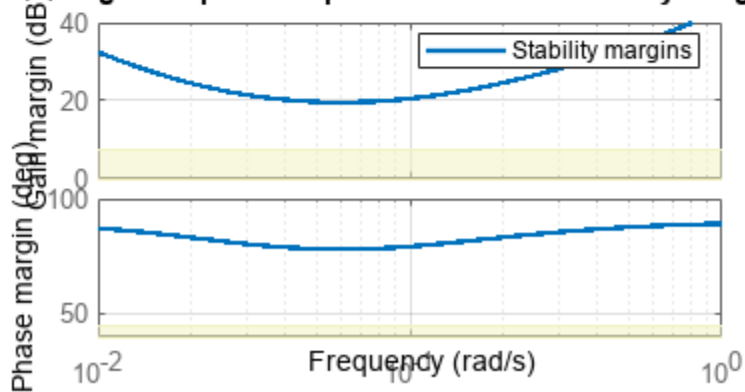
Open loop CG: Minimum and maximum loop gains (CrossTo**Margins at plant inputs: Disk-based stability margins****Margins at plant outputs: Disk-based stability margins**

The first plot shows that the open-loop gain crossovers fall close to the specified interval [0.1,1]. This plot also includes the tuned values of the sensitivity function $S = \text{inv}(1-G*C)$ and complementary sensitivity $T = 1-S$. These curves reflect the constraints that `looptune` imposes on S and T to enforce the target crossover range w_c .

The second and third plots show that the MIMO stability margins of the tuned system fall well within the target range.

Alternatives

For analyzing Simulink models tuned with `looptune` through an `sITuner` interface, use `loopview` for `sITuner` (requires Simulink Control Design).

See Also

`looptune` | `sITuner` | `looptune` (for `sITuner`) | `loopview` (for `sITuner`)

Topics

“Tune MIMO Control System for Specified Bandwidth”

“Decoupling Controller for a Distillation Column”

lyap

Continuous Lyapunov equation solution

Syntax

```
lyap
X = lyap(A,Q)
X = lyap(A,B,C)
X = lyap(A,Q,[],E)
```

Description

`lyap` solves the special and general forms of the Lyapunov equation. Lyapunov equations arise in several areas of control, including stability theory and the study of the RMS behavior of systems.

`X = lyap(A,Q)` solves the Lyapunov equation

$$AX + XA^T + Q = 0$$

where A and Q represent square matrices of identical sizes. If Q is a symmetric matrix, the solution X is also a symmetric matrix.

`X = lyap(A,B,C)` solves the Sylvester equation

$$AX + XB + C = 0$$

The matrices A , B , and C must have compatible dimensions but need not be square.

`X = lyap(A,Q,[],E)` solves the generalized Lyapunov equation

$$AXE^T + EXA^T + Q = 0$$

where Q is a symmetric matrix. You must use empty square brackets `[]` for this function. If you place any values inside the brackets, the function errors out.

Limitations

The continuous Lyapunov equation has a unique solution if the eigenvalues $\alpha_1, \alpha_2, \dots, \alpha_n$ of A and $\beta_1, \beta_2, \dots, \beta_n$ of B satisfy

$$\alpha_i + \beta_j \neq 0 \quad \text{for all pairs } (i, j)$$

If this condition is violated, `lyap` produces the error message:

Solution does not exist or is not unique.

Examples

Example 1

Solve Lyapunov Equation

Solve the Lyapunov equation

$$AX + XA^T + Q = 0$$

where

$$A = \begin{bmatrix} 1 & 2 \\ -3 & -4 \end{bmatrix} \quad Q = \begin{bmatrix} 3 & 1 \\ 1 & 1 \end{bmatrix}$$

The A matrix is stable, and the Q matrix is positive definite.

```
A = [1 2; -3 -4];
```

```
Q = [3 1; 1 1];
```

```
X = lyap(A,Q)
```

These commands return the following X matrix:

```
X =
```

```
    6.1667    -3.8333
   -3.8333     3.0000
```

You can compute the eigenvalues to see that X is positive definite.

```
eig(X)
```

The command returns the following result:

```
ans =
```

```
    0.4359
    8.7308
```

Example 2

Solve Sylvester Equation

Solve the Sylvester equation

$$AX + XB + C = 0$$

where

$$A = 5 \quad B = \begin{bmatrix} 4 & 3 \\ 4 & 3 \end{bmatrix} \quad C = [2 \ 1]$$

```
A = 5;
```

```
B = [4 3; 4 3];
```

```
C = [2 1];
```

```
X = \lyap(A,B,C)
```

These commands return the following X matrix:

X =

-0.2000 -0.0500

Algorithms

lyap uses SLICOT routines SB03MD and SG03AD for Lyapunov equations and SB04MD (SLICOT) and ZTRSYL (LAPACK) for Sylvester equations.

Version History

Introduced before R2006a

References

- [1] Bartels, R.H. and G.W. Stewart, "Solution of the Matrix Equation $AX + XB = C$," *Comm. of the ACM*, Vol. 15, No. 9, 1972.
- [2] Barraud, A.Y., "A numerical algorithm to solve $A X A - X = Q$," *IEEE Trans. Auto. Contr.*, AC-22, pp. 883-885, 1977.
- [3] Hammarling, S.J., "Numerical solution of the stable, non-negative definite Lyapunov equation," *IMA J. Num. Anal.*, Vol. 2, pp. 303-325, 1982.
- [4] Penzl, T., "Numerical solution of generalized Lyapunov equations," *Advances in Comp. Math.*, Vol. 8, pp. 33-48, 1998.
- [5] Golub, G.H., Nash, S. and Van Loan, C.F., "A Hessenberg-Schur method for the problem $AX + XB = C$," *IEEE Trans. Auto. Contr.*, AC-24, pp. 909-913, 1979.

See Also

covar | dlyap

lyapchol

Square-root solver for continuous-time Lyapunov equation

Syntax

```
R = lyapchol(A,B)
R = lyapchol(A,B,E)
```

Description

`R = lyapchol(A,B)` computes a Cholesky factorization $X = R' * R$ of the solution X to the Lyapunov matrix equation:

$$A * X + X * A' + B * B' = 0$$

All eigenvalues of matrix A must lie in the open left half-plane for R to exist.

`R = lyapchol(A,B,E)` computes a Cholesky factorization $X = R' * R$ of X solving the generalized Lyapunov equation:

$$A * X * E' + E * X * A' + B * B' = 0$$

All generalized eigenvalues of (A,E) must lie in the open left half-plane for R to exist.

Algorithms

`lyapchol` uses SLICOT routines SB03OD and SG03BD.

Version History

Introduced before R2006a

References

- [1] Bartels, R.H. and G.W. Stewart, "Solution of the Matrix Equation $AX + XB = C$," *Comm. of the ACM*, Vol. 15, No. 9, 1972.
- [2] Hammarling, S.J., "Numerical solution of the stable, non-negative definite Lyapunov equation," *IMA J. Num. Anal.*, Vol. 2, pp. 303-325, 1982.
- [3] Penzl, T., "Numerical solution of generalized Lyapunov equations," *Advances in Comp. Math.*, Vol. 8, pp. 33-48, 1998.

See Also

`lyap` | `dlyapchol`

mag2db

Convert magnitude to decibels (dB)

Syntax

```
ydb = mag2db(y)
```

Description

`ydb = mag2db(y)` expresses in decibels (dB) the magnitude measurements specified in `y`. The relationship between magnitude and decibels is $y_{db} = 20 * \log_{10}(y)$

Examples

Display Gain Margins in Decibels

For this example, consider the following SISO feedback loop where the system contains multiple gain crossover or phase crossover frequencies, which leads to multiple gain or phase margin values:

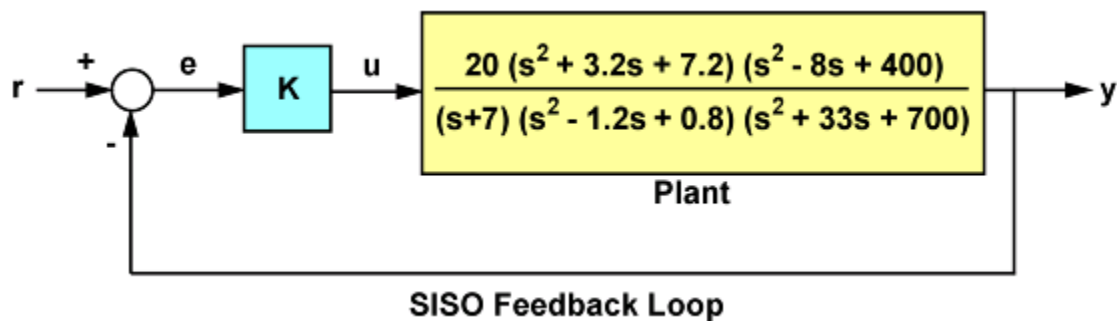

Create the transfer function.

```
G = tf(20,[1 7]) * tf([1 3.2 7.2],[1 -1.2 0.8]) * tf([1 -8 400],[1 33 700]);
```

Use the `allmargin` command to compute all stability margins.

```
m = allmargin(G)
```

```
m = struct with fields:
  GainMargin: [0.3408 3.3920]
  GMFrequency: [1.9421 16.4807]
  PhaseMargin: 68.1140
  PMFrequency: 7.0776
  DelayMargin: 0.1680
  DMFrequency: 7.0776
  Stable: 1
```

Note that gain margins are expressed as gain ratios and not in decibels (dB). Use `mag2db` to convert the values to dB.

```
GainMargins_dB = mag2db(m.GainMargin)
GainMargins_dB = 1×2
    -9.3510    10.6091
```

Input Arguments

y — Input array

scalar | vector | matrix | array

Input array, specified as a scalar, vector, matrix, or an array. When *y* is nonscalar, `mag2db` is an element-wise operation.

Data Types: `single` | `double`

Complex Number Support: Yes

Output Arguments

ydb — Magnitude measurements in decibels

scalar | vector | matrix | array

Magnitude measurements in decibels, returned as a scalar, vector, matrix, or an array of the same size as *y*.

Version History

Introduced in R2008a

See Also

`db2mag`

make1DOF

Convert 2-DOF PID controller to 1-DOF controller

Syntax

```
C1 = make1DOF(C2)
```

Description

C1 = make1DOF(C2) converts the two-degree-of-freedom PID controller C2 to one degree of freedom by removing the terms that depend on coefficients *b* and *c*.

Examples

Convert 2-DOF PID controller to 1-DOF

Design a 2-DOF PID controller for a plant.

```
G = tf(1,[1 0.5 0.1]);
C2 = pidtune(G,'pidf2',1.5)
```

C2 =

$$u = K_p (b*r-y) + K_i \frac{1}{s} (r-y) + K_d \frac{s}{T_f*s+1} (c*r-y)$$

with $K_p = 1.12$, $K_i = 0.23$, $K_d = 1.3$, $T_f = 0.122$, $b = 0.664$, $c = 0.0136$

Continuous-time 2-DOF PIDF controller in parallel form.

Convert the controller to one degree of freedom.

```
C1 = make1DOF(C2)
```

C1 =

$$K_p + K_i * \frac{1}{s} + K_d * \frac{s}{T_f*s+1}$$

with $K_p = 1.12$, $K_i = 0.23$, $K_d = 1.3$, $T_f = 0.122$

Continuous-time PIDF controller in parallel form.

The new controller has the same PID gains and filter constant. However, make1DOF removes the terms involving the setpoint weights *b* and *c*. Therefore, in a closed loop with the plant *G*, the 2-DOF controller *C2* yields a different closed-loop response from *C1*.

```
CM = tf(C2);
T2 = CM(1)*feedback(G,-CM(2));
```

```
T1 = feedback(G*C1,1);
stepplot(T2,T1,'r--')
```

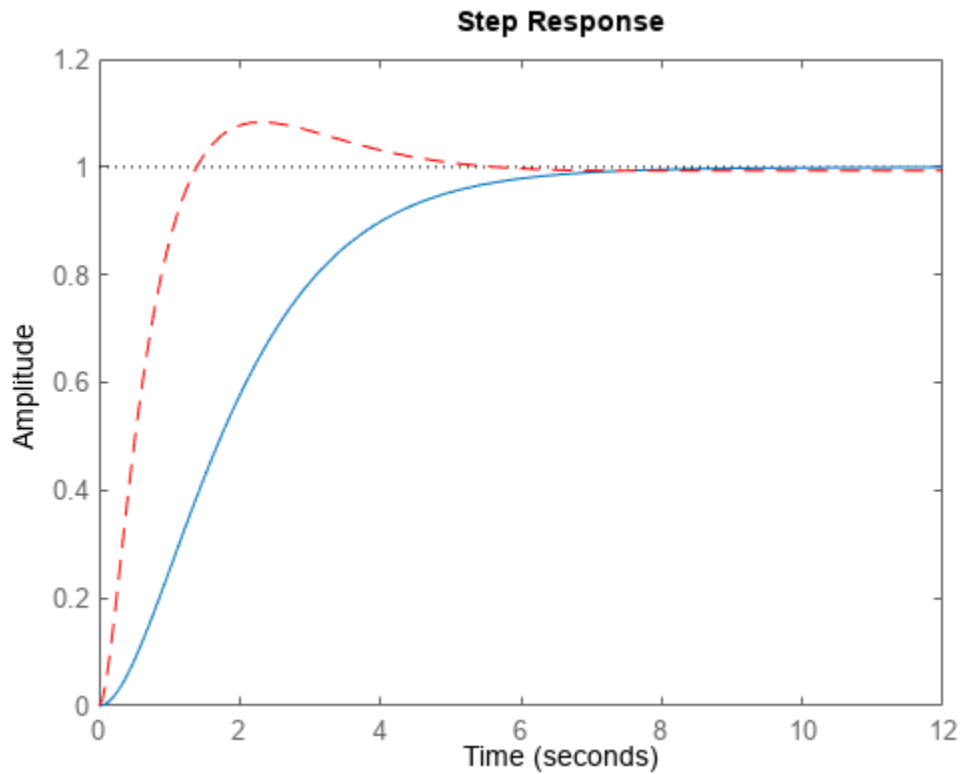

Input Arguments

C2 — 2-DOF PID controller

`pid2` object | `pidstd2` object

2-DOF PID controller, specified as a `pid2` object or a `pidstd2` object.

Output Arguments

C1 — 1-DOF PID controller

`pid` object | `pidstd` object

1-DOF PID controller, returned as a `pid` or `pidstd` object. C1 is in parallel form if C2 is in parallel form, and standard form if C2 is in standard form.

For example, suppose C2 is a continuous-time, parallel-form 2-DOF `pid2` controller. The relationship between the inputs, r and y , and the output u of C2 is given by:

$$u = K_p(br - y) + \frac{K_i}{s}(r - y) + \frac{K_d s}{T_f s + 1}(cr - y).$$

Then C1 is a parallel-form 1-DOF `pid` controller of the form:

$$C_1 = K_p + \frac{K_i}{s} + \frac{K_d s}{T_f s + 1}.$$

The PID gains K_p , K_i , and K_d , and the filter time constant T_f are unchanged. `make1DOF` removes the terms that depend on the setpoint weights b and c . For more information about 2-DOF PID controllers, see “Two-Degree-of-Freedom PID Controllers”.

The conversion also preserves the values of the properties `Ts`, `TimeUnit`, `Sampling Grid`, `IFormula`, and `DFormula`.

Version History

Introduced in R2015b

See Also

`pid2` | `pidstd2` | `pid` | `pidstd` | `make2DOF` | `getComponents`

Topics

“Two-Degree-of-Freedom PID Controllers”

make2DOF

Convert 1-DOF PID controller to 2-DOF controller

Syntax

```
C2 = make2DOF(C1)
C2 = make2DOF(C1,b)
C2 = make2DOF(C1,b,c)
```

Description

`C2 = make2DOF(C1)` converts the one-degree-of-freedom PID controller `C1` to two degrees of freedom. The setpoint weights b and c of the 2-DOF controller are 1, and the remaining PID coefficients do not change.

`C2 = make2DOF(C1,b)` specifies the setpoint weight for the proportional term.

`C2 = make2DOF(C1,b,c)` specifies the setpoint weights for both the proportional and derivative terms.

Examples

Convert 1-DOF PID controller to 2-DOF

Design a 1-DOF PID controller for a plant.

```
G = tf(1,[1 0.5 0.1]);
C1 = pidtune(G,'pidf',1.5)
```

`C1 =`

$$K_p + K_i * \frac{1}{s} + K_d * \frac{s}{T_f*s+1}$$

with $K_p = 1.12$, $K_i = 0.23$, $K_d = 1.3$, $T_f = 0.122$

Continuous-time PIDF controller in parallel form.

Convert the controller to two degrees of freedom.

```
C2 = make2DOF(C1)
```

`C2 =`

$$u = K_p (b*r-y) + K_i \frac{1}{s} (r-y) + K_d \frac{s}{T_f*s+1} (c*r-y)$$

with $K_p = 1.12$, $K_i = 0.23$, $K_d = 1.3$, $T_f = 0.122$, $b = 1$, $c = 1$

Continuous-time 2-DOF PIDF controller in parallel form.

The new controller has the same PID gains and filter constant. It also contains new terms involving the setpoint weights b and c . By default, $b = c = 1$. Therefore, in a closed loop with the plant G , the 2-DOF controller $C2$ yields the same response as $C1$.

```
T1 = feedback(G*C1,1);
CM = tf(C2);
T2 = CM(1)*feedback(G,-CM(2));
stepplot(T1,T2,'r--')
```

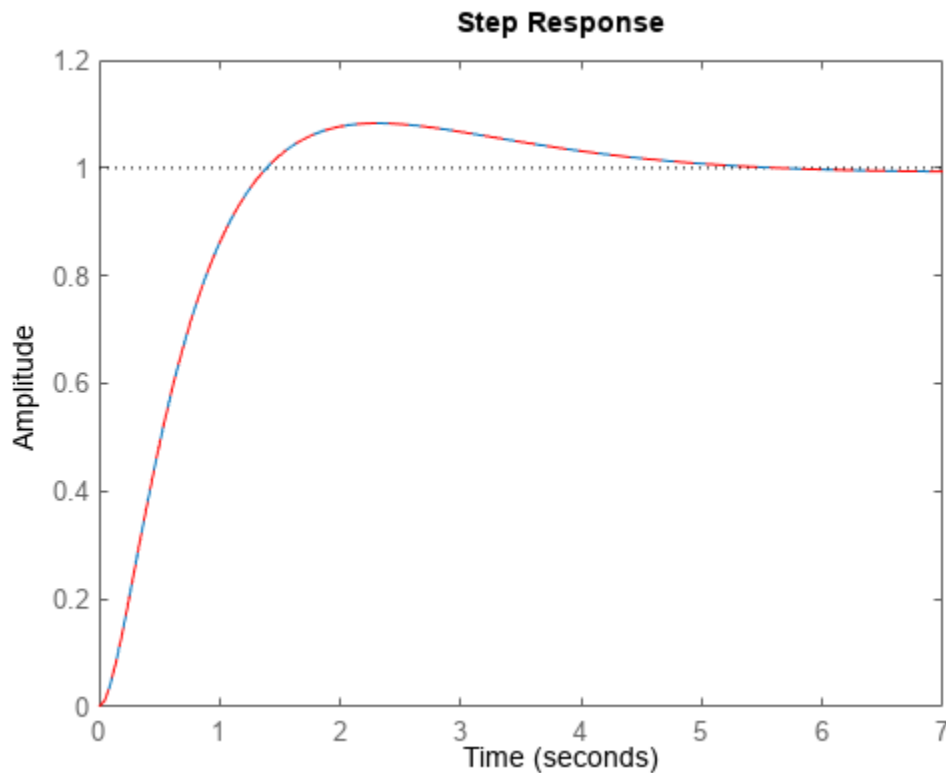

Convert $C1$ to a 2-DOF controller with different b and c values.

```
C2_2 = make2DOF(C1,0.5,0.75)
```

```
C2_2 =
```

$$u = K_p (b \cdot r - y) + K_i \frac{1}{s} (r - y) + K_d \frac{s}{T_f s + 1} (c \cdot r - y)$$

with $K_p = 1.12$, $K_i = 0.23$, $K_d = 1.3$, $T_f = 0.122$, $b = 0.5$, $c = 0.75$

Continuous-time 2-DOF PIDF controller in parallel form.

The PID gains and filter constant are still unchanged, but the setpoint weights now change the closed-loop response.

```

CM_2 = tf(C2_2);
T2_2 = CM_2(1)*feedback(G, -CM_2(2));
stepplot(T1,T2_2,'r--')

```

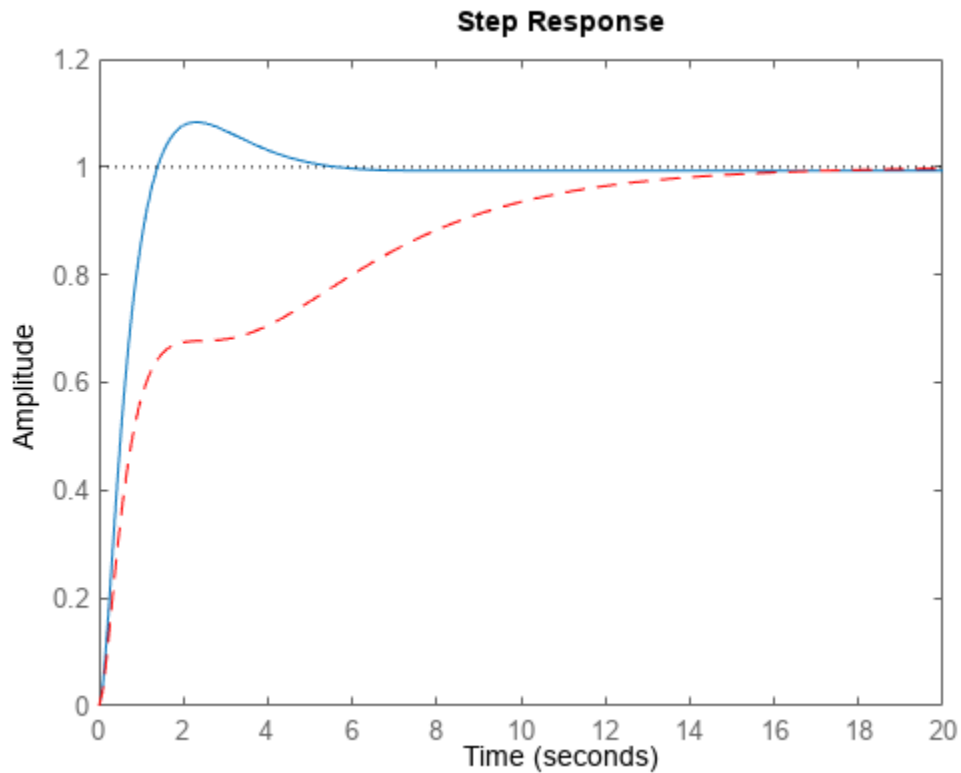

Input Arguments

C1 — 1-DOF PID controller

pid object | pidstd object

1-DOF PID controller, specified as a pid object or a pidstd object.

b — Setpoint weight on proportional term

1 (default) | real nonnegative scalar

Setpoint weight on proportional term, specified as a real, nonnegative, finite value. If you do not specify b, then C2 has b = 1.

c — Setpoint weight on derivative term

1 (default) | real nonnegative scalar

Setpoint weight on derivative term, specified as a real, nonnegative, finite value. If you do not specify c, then C2 has c = 1.

Output Arguments

C2 — 2-DOF PID controller

pid2 object | pidstd2 object

2-DOF PID controller, returned as a pid2 object or pidstd2 object. C2 is in parallel form if C1 is in parallel form, and standard form if C1 is in standard form.

For example, suppose C1 is a continuous-time, parallel-form pid controller of the form:

$$C_1 = K_p + \frac{K_i}{s} + \frac{K_d s}{T_f s + 1}.$$

Then C2 is a parallel-form 2-DOF pid2 controller, which has two inputs and one output. The relationship between the inputs, r and y , and the output u of C2 is given by:

$$u = K_p(br - y) + \frac{K_i}{s}(r - y) + \frac{K_d s}{T_f s + 1}(cr - y).$$

The PID gains K_p , K_i , and K_d , and the filter time constant T_f are unchanged. The setpoint weights b and c are specified by the input arguments b and c , or 1 by default. For more information about 2-DOF PID controllers, see “Two-Degree-of-Freedom PID Controllers”.

The conversion also preserves the values of the properties T_s , TimeUnit, Sampling Grid, IFormula, and DFormula.

Version History

Introduced in R2015b

See Also

pid2 | pidstd2 | pid | pidstd | make1DOF | getComponents

Topics

“Two-Degree-of-Freedom PID Controllers”

margin

Gain margin, phase margin, and crossover frequencies

Syntax

```
margin(sys)
margin(sys,w)
```

```
[Gm,Pm,Wcg,Wcp] = margin(sys)
[Gm,Pm,Wcg,Wcp] = margin(mag,phase,w)
[Gm,Pm] = margin(sys,J1,...,JN)
```

Description

`margin(sys)` plots the Bode response of `sys` on the screen and indicates the gain and phase margins on the plot. Gain margins are expressed in dB on the plot.

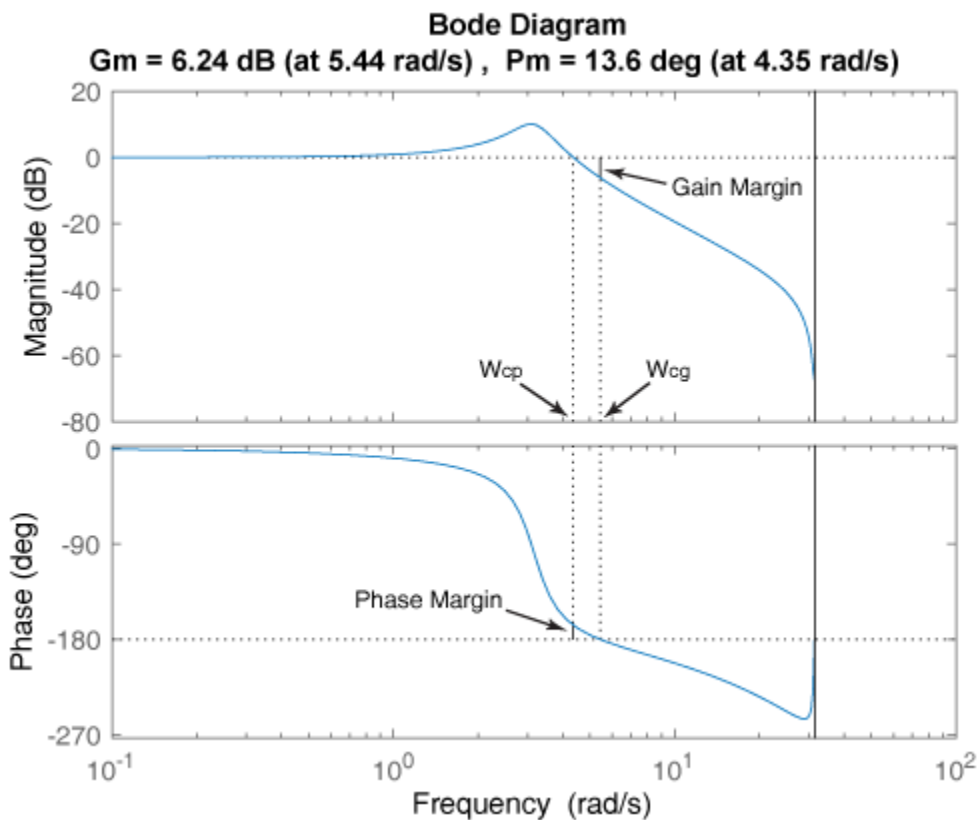

Solid vertical lines mark the gain margin and phase margin. The dashed vertical lines indicate the locations of W_{cp} , the frequency where the phase margin is measured, and W_{cg} , the frequency where the gain margin is measured. The plot title includes the magnitude and location of the gain and phase margin.

Gm and Pm of a system indicate the relative stability of the closed-loop system formed by applying unit negative feedback to `sys`, as shown in the following figure.

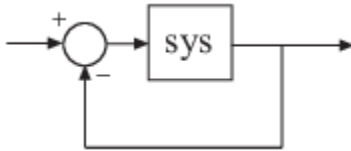

Gm is the amount of gain variance required to make the loop gain unity at the frequency ω_{cg} where the phase angle is -180° (modulo 360°). In other words, the gain margin is $1/g$ if g is the gain at the -180° phase frequency. Similarly, the phase margin is the difference between the phase of the response and -180° when the loop gain is 1.0.

The frequency ω_{cp} at which the magnitude is 1.0 is called the *unity-gain frequency* or *gain crossover frequency*. Usually, gain margins of three or more combined with phase margins between 30° and 60° result in reasonable tradeoffs between bandwidth and stability.

`margin(sys, w)` plots the Bode response of `sys` using the vector of frequencies `w` in radian/TimeUnit. Use this syntax when you have sparse models like `sparss` or `mechss` model objects.

`[Gm, Pm, Wcg, Wcp] = margin(sys)` returns the gain margin Gm in absolute units, the phase margin Pm, and the corresponding frequencies Wcg and Wcp, of `sys`. Wcg is the frequency where the gain margin is measured, which is a -180° phase crossing frequency. Wcp is the frequency where the phase margin is measured, which is a 0-dB gain crossing frequency. These frequencies are expressed in radians/TimeUnit, where TimeUnit is the unit specified in the TimeUnit property of `sys`. When `sys` has several crossovers, `margin` returns the smallest gain and phase margins and corresponding frequencies.

`margin` returns a warning if your system is not internally stable, that is, if your system is not closed-loop stable or contains pole-zero cancellations outside of the open left-half plane.

`[Gm, Pm, Wcg, Wcp] = margin(mag, phase, w)` derives the gain and phase margins from frequency response data. Provide the gain data `mag` in absolute units, and phase data `phase` in degrees. You can provide the frequency vector `w` in any units and `margin` returns Wcg and Wcp in the same units.

`[Gm, Pm] = margin(sys, J1, ..., JN)` returns the gain margin Gm and phase margin Pm of the entries in model array `sys` with subscripts (J1, ..., JN).

Examples

Plot Gain and Phase Margins of Transfer Function

For this example, create a continuous transfer function.

```
sys = tf(1,[1 2 1 0])
```

```
sys =
```

```

      1
-----
s^3 + 2 s^2 + s
```

Continuous-time transfer function.

Display the gain and phase margins graphically.

```
margin(sys)
```

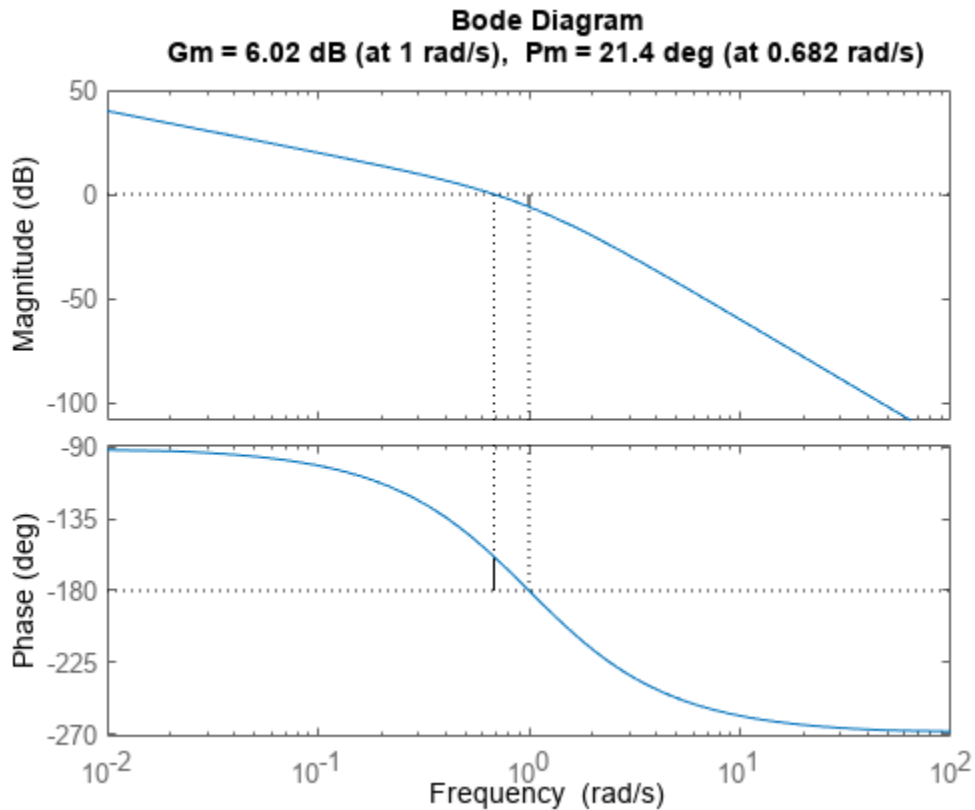

The gain margin (6.02 dB) and phase margin (21.4 deg), displayed in the title, are marked with solid vertical lines. The dashed vertical lines indicate the locations of ω_{cg} , the frequency where the gain margin is measured, and ω_{cp} , the frequency where the phase margin is measured.

Gain and Phase Margins of Transfer Function

For this example, create a discrete-time transfer function.

```
sys = tf([0.04798 0.0464],[1 -1.81 0.9048],0.1)
```

```
sys =
```

$$\frac{0.04798 z + 0.0464}{z^2 - 1.81 z + 0.9048}$$

```
Sample time: 0.1 seconds  
Discrete-time transfer function.
```

Compute the gain margin, phase margin and frequencies.

```
[Gm,Pm,Wcg,Wcp] = margin(sys)
```

```
Gm = 2.0517
```

```
Pm = 13.5712
```

```
Wcg = 5.4374
```

```
Wcp = 4.3544
```

The results indicate that a gain variation of over 2.05 (6.24 dB) at the phase crossover frequency of 5.43 rad/s would cause the system to be unstable. Similarly a phase variation of over 13.57 degrees at the gain crossover frequency of 4.35 rad/s will cause the system to lose stability.

Gain and Phase Margins using Frequency Response Data

For this example, load the frequency response data of an open loop system, consisting of magnitudes (m) and phase values (p) measured at the frequencies in w.

```
load('openLoopFRD.mat','p','m','w');
```

Compute the gain and phase margins.

```
[Gm,Pm,Wcg,Wcp] = margin(m,p,w)
```

```
Gm = 0.6249
```

```
Pm = 48.9853
```

```
Wcg = 1.2732
```

```
Wcp = 1.5197
```

Gain and Phase Margins of Models in an Array

For this example, load `invertedPendulumArray.mat`, which contains a 3-by-3 array of inverted pendulum models. The mass of the pendulum varies as you move from model to model along a single column of `sys`, and the length of the pendulum varies as you move along a single row. The mass values used are 100g, 200g and 300g, and the pendulum lengths used are 3m, 2m and 1m respectively.

	Column 1	Column 2	Column 3
Row 1	100g, 3m	100g, 2m	100g, 1m
Row 2	200g, 3m	200g, 2m	200g, 1m
Row 3	300g, 3m	300g, 2m	300g, 1m

```
load('invertedPendulumArray.mat','sys');
size(sys)
```

```
3x3 array of transfer functions.
Each model has 1 outputs and 1 inputs.
```

Find gain and phase margin for all models in the array.

```
[Gm,Pm] = margin(sys)
```

```
Gm = 3×3
```

```
    0.9800    0.9800    0.9800
    0.9800    0.9800    0.9800
    0.9800    0.9800    0.9800
```

```
Pm = 3×3
```

```
 -11.3798 -11.4118 -11.4433
 -11.4059 -11.4296 -11.4532
 -11.4228 -11.4410 -11.4592
```

`margin` returns two arrays, `Gm` and `Pm`, in which each entry is the gain and phase margin values of the corresponding entry in `sys`. For instance, the gain and phase margin of the model with 100g pendulum weight and 2m length is `Gm(1,2)` and `Pm(1,2)`, respectively.

Input Arguments

sys — Dynamic system

dynamic system model | model array

Dynamic system, specified as a SISO dynamic system model, or an array of SISO dynamic system models. Dynamic systems that you can use include continuous-time or discrete-time numeric LTI models such as `tf`, `zpk`, `ss`, `sparss` or `mechss` models.

If `sys` is a generalized state-space model `genss` or an uncertain state-space model `uss`, `margin` returns the gain margin and phase margin of the current or nominal value of `sys`. If `sys` is an array of models, `margin` returns the `Gm` and `Pm` of the model corresponding to its subscript `J1, . . . , JN` in `sys`. For more information on model arrays, see “Model Arrays”.

J1, . . . , JN — Indices of models in array whose gain and phase margins you want to extract

positive integer

Indices of models in array whose gain and phase margins you want to extract, specified as positive integers. You can provide as many indices as there are array dimensions in `sys`. For example, if `sys` is a 4-by-5 array of dynamic system models, the following command extracts `Gm` and `Pm` for entry (2,3) in the array.

```
[Gm,Pm] = margin(sys,2,3);
```

mag — Magnitude of system response

3-D array

Magnitude of the system response in absolute units, specified as a 3-D array. Since `margin` only accepts SISO systems, `mag` is a 1-by-1-by-`N` array, where `N` is the number of frequency points. For an example, see “Obtain Magnitude and Phase Data” on page 2-66.

phase — Phase of system response

3-D array

Phase of the system response in degrees, specified as a 3-D array. Since `margin` only accepts SISO systems, phase is a 1-by-1-by-N array, where N is the number of frequency points. For an example, see “Obtain Magnitude and Phase Data” on page 2-66.

w — Frequencies at which the magnitude and phase values of system response are obtained

column vector

Frequencies at which the magnitude and phase values of system response are obtained, specified as a column vector.

Output Arguments

Gm — Gain margin

scalar | array

Gain margin, returned as a scalar or an array. If `sys` is:

- A single model, then `Gm` is returned as a scalar.
- A model array, then `Gm` is an array of gain margins of each model in `sys`.

`Gm` is the amount of gain variance required to make the loop gain unity at the frequency `Wcg` where the phase angle is -180° (modulo 360°). In other words, the gain margin is $1/g$ if g is the gain at the -180° phase frequency. Negative gain margins indicate that stability is lost by decreasing the gain, while positive gain margins indicate that stability is lost by increasing the gain

The gain margin `Gm` is computed in absolute units. You can compute the gain margin in dB by,

$$Gm_dB = 20 * \log_{10}(Gm)$$

Pm — Phase margin

scalar | array

Phase margin, returned as a scalar or an array. If `sys` is:

- A single model, then `Pm` is returned as a scalar.
- A model array, then `Pm` is an array of phase margins of each model in `sys`.

The phase margin is the difference between the phase of the response and -180° when the loop gain is 1.0.

The phase margin `Pm` is expressed in degrees.

Wcg — Phase crossover frequency

scalar

Phase crossover frequency, returned as a scalar. `Wcg` is the frequency where the gain margin is measured, which is a -180° phase crossing frequency.

`Wcg` is expressed in radians/`TimeUnit`, where `TimeUnit` is the unit specified in the `TimeUnit` property of `sys`.

Wcp — Gain crossover frequency

scalar

Gain crossover frequency, returned as a scalar. `Wcp` is the frequency where the phase margin is measured, which is a 0-dB gain crossing frequency.

`Wcp` is expressed in radians/`TimeUnit`, where `TimeUnit` is the unit specified in the `TimeUnit` property of `sys`.

Tips

- When you use `margin(mag,phase,w)`, `margin` relies on interpolation to approximate the margins, which generally produce less accurate results. For example, if there is no 0-dB crossing within the `w` range, `margin` returns a phase margin of `Inf`. Therefore, if you have an analytical model `sys`, using `[Gm,Pm,Wcg,Wcp] = margin(sys)` is a more robust way to obtain the margins.

Version History

Introduced before R2006a

See Also

`bode` | **Linear System Analyzer** | `allmargin`

Topics

“Assessing Gain and Phase Margins”

mechss

Sparse second-order state-space model

Description

Use `mechss` to represent second-order sparse models using matrices obtained from your finite element analysis (FEA) package. Such sparse models arise from finite element analysis (FEA) and are useful in fields like structural analysis, fluid flow, heat transfer, and electromagnetics. The resultant matrices from this type of modeling are quite large with a sparse pattern. Hence, using `mechss` is an efficient way to represent such large sparse state-space models in MATLAB to perform linear analysis. You can also use `mechss` to convert a first-order `sparss` model object or other dynamic system models to a `mechss` object.

You can use `mechss` model objects to represent SISO or MIMO state-space models in continuous time or discrete time. In continuous time, a second-order sparse mass-spring-damper model is represented in the following form:

$$\begin{aligned} M \ddot{q}(t) + C \dot{q}(t) + K q(t) &= B u(t) \\ y(t) &= F q(t) + G \dot{q}(t) + D u(t) \end{aligned}$$

Here, the full state vector is given by $[q, \dot{q}]$ where q and \dot{q} are the displacement and velocity vectors. u and y represent the inputs and outputs, respectively. M , C and K represent the mass, damping and stiffness matrices, respectively. B is the input matrix while F and G are the output matrices for displacement and velocity, respectively. D is the input-to-output matrix.

You can use a `mechss` object to:

- Perform time-domain and frequency-domain response analysis.
- Specify signal-based connections with other LTI models.
- Specify physical interfaces between components using the `interface` command.

For more information, see “Sparse Model Basics”.

Creation

Syntax

```
sys = mechss(M,C,K,B,F,G,D)
sys = mechss(M,C,K,B,F,G,D,ts)
sys = mechss(M,C,K)
sys = mechss(D)
sys = mechss( ___,Name,Value)
```

```
sys = mechss(ltiSys)
```

Description

`sys = mechss(M,C,K,B,F,G,D)` creates a `mechss` object representing this continuous-time second-order mass-spring-damper model:

$$\begin{aligned} M \ddot{q}(t) + C \dot{q}(t) + K q(t) &= B u(t) \\ y(t) &= F q(t) + G \dot{q}(t) + D u(t) \end{aligned}$$

Here, M , C , and K represent the mass, damping, and stiffness matrices, respectively. B is the input-to-state matrix while F and G are the displacement-to-output and velocity-to-output matrices resulting from the two components of the state x . D is the input-to-output matrix. You can set M to `[]` when the mass matrix is an identity matrix. Set G and D to `[]` or omit them when they are empty.

`sys = mechss(M,C,K,B,F,G,D,ts)` uses the sample time `ts` to create a `mechss` object representing this discrete-time second-order mass-spring-damper model:

$$\begin{aligned} M q[k+2] + C q[k+1] + K q[k] &= B u[k] \\ y[k] &= F q[k] + G q[k+1] + D u[k] \end{aligned}$$

To leave the sample time unspecified, set `ts` to `-1`.

`sys = mechss(M,C,K)` creates a `mechss` model object with the following assumptions:

- Identity matrices for B and F with the same size as mass matrix M
- Matrices of zeros for G and D

`sys = mechss(D)` creates a `mechss` model object that represents the static gain D . The output sparse state-space model is equivalent to `mechss([],[],[],[],[],[],D)`.

`sys = mechss(___, Name, Value)` sets properties of the second-order sparse state-space model using one or more name-value pair arguments. Use this syntax with any of the previous input-argument combinations.

`sys = mechss(ltiSys)` converts the dynamic system model `ltiSys` to a second-order sparse state-space model.

Input Arguments**M — Mass matrix**

N_q-by-N_q sparse matrix

Mass matrix, specified as an N_q -by- N_q sparse matrix, where N_q is the number of degrees of freedom. This input sets the value of property `M`.

C — Damping matrix

N_q-by-N_q sparse matrix

Damping matrix, specified as an N_q -by- N_q sparse matrix, where N_q is the number of degrees of freedom. You can also set `C=[]` to specify zero damping. This input sets the value of property `C`.

K — Stiffness matrix

N_q-by-N_q sparse matrix

Stiffness matrix, specified as an N_q -by- N_q sparse matrix, where N_q is the number of degrees of freedom. This input sets the value of property `K`.

B — Input-to-state matrix

Nq-by-Nu sparse matrix

Input-to-state matrix, specified as an Nq-by-Nu sparse matrix, where Nq is the number of degrees of freedom and Nu is the number of inputs. This input sets the value of property B.

F — Displacement-to-output matrix

Ny-by-Nq sparse matrix

Displacement-to-output matrix, specified as an Ny-by-Nq sparse matrix, where Nq is the number of degrees of freedom and Ny is the number of outputs. This input sets the value of property F.

G — Velocity-to-output matrix

Ny-by-Nq sparse matrix

Velocity-to-output matrix, specified as an Ny-by-Nq sparse matrix, where Nq is the number of degrees of freedom and Ny is the number of outputs. This input sets the value of property G.

D — Input-to-output matrix

Ny-by-Nu sparse matrix

Input-to-output matrix, specified as an Ny-by-Nu sparse matrix, where Ny is the number of outputs and Nu is the number of inputs. This input sets the value of property D.

ts — Sample time

scalar

Sample time, specified as a scalar. For more information see the Ts property.

ltiSys — Dynamic system to convert to second-order sparse state-space form

dynamic system model | model array

Dynamic system to convert to second-order sparse state-space form, specified as a SISO or MIMO dynamic system model or array of dynamic system models. Dynamic systems that you can convert include:

- Continuous-time or discrete-time numeric LTI models, such as sparss, tf, zpk, ss, or pid models.

Output Arguments**sys — Output system model**

mechss model object

Output system model, returned as a mechss model object.

Properties**M — Mass matrix**

Nq-by-Nq sparse matrix

Mass matrix, specified as an Nq-by-Nq sparse matrix where, Nq is the number of degrees of freedom.

C — Damping matrix

Nq-by-Nq sparse matrix

Damping matrix, specified as an N_q -by- N_q sparse matrix where, N_q is the number of degrees of freedom.

K — Stiffness matrix

N_q -by- N_q sparse matrix

Damping matrix, specified as an N_q -by- N_q sparse matrix where, N_q is the number of degrees of freedom.

B — Input-to-state matrix

N_q -by- N_u sparse matrix

Input-to-state matrix, specified as an N_q -by- N_u sparse matrix where, N_q is the number of degrees of freedom and N_u is the number of inputs.

F — Displacement-to-output matrix

N_y -by- N_q sparse matrix

Displacement-to-output matrix, specified as an N_y -by- N_q sparse matrix where, N_q is the number of degrees of freedom and N_y is the number of outputs.

G — Velocity-to-output matrix

N_y -by- N_q sparse matrix

Velocity-to-output matrix, specified as an N_y -by- N_q sparse matrix where, N_q is the number of degrees of freedom and N_y is the number of outputs.

D — Input-to-output matrix

N_y -by- N_u sparse matrix

Input-to-output matrix, specified as an N_y -by- N_u sparse matrix where, N_y is the number of outputs and N_u is the number of inputs. D is also called the static gain matrix, and represents the ratio of the output to the input in steady state condition.

StateInfo — State partition information

structure array

State partition information containing state vector components, interfaces between components and internal signal connecting components, specified as a structure array with the following fields:

- **Type** — Type includes component, signal or physical interface
- **Name** — Name of the component, signal or physical interface
- **Size** — Number of states or degrees of freedom in the partition

You can view the partition information of the sparse state-space model using `showStateInfo`. You can also sort and order the partitions in your sparse model using `xsort`.

SolverOptions — Options for model analysis

structure

Options for model analysis, specified as a structure with the following fields:

- **UseParallel** — Set this option to `true` to enable parallel computing and `false` to disable it. Parallel computing is disabled by default. The `UseParallel` option requires a Parallel Computing Toolbox license.

- **DAESolver** — Use this option to select the type of differential algebraic equation (DAE) solver. The following DAE solvers are available:
 - `'trbdf2'` — Fixed-step solver with an accuracy of $o(h^2)$, where h is the step size.[2] This is the default solver for the `mechss` model object.
 - `'trbdf3'` — Fixed-step solver with an accuracy of $o(h^3)$, where h is the step size.
 - `'hht'` — Fixed-step solver with an accuracy of $o(h^2)$, where h is the step size.[1]

Reducing the step size increases accuracy and extends the frequency range where numerical damping is negligible. `'hht'` is the fastest but can run into difficulties with high initial acceleration (for example, an impulse response with initial jerk). `'trbdf2'` requires about twice as many computations as `'hht'` and `'trbdf3'` requires another 50% more computations than `'trbdf2'`.

For an example, see “Time and Frequency Response of Sparse Second-Order Model” on page 2-736.

InternalDelay — Internal delays in the model

vector

Internal delays in the model, specified as a vector. Internal delays arise, for example, when closing feedback loops on systems with delays, or when connecting delayed systems in series or parallel. For more information about internal delays, see “Closing Feedback Loops with Time Delays”.

For continuous-time models, internal delays are expressed in the time unit specified by the `TimeUnit` property of the model. For discrete-time models, internal delays are expressed as integer multiples of the sample time T_s . For example, `InternalDelay = 3` means a delay of three sampling periods.

You can modify the values of internal delays using the property `InternalDelay`. However, the number of entries in `sys.InternalDelay` cannot change, because it is a structural property of the model.

InputDelay — Input delay

0 (default) | scalar | Nu-by-1 vector

Input delay for each input channel, specified as one of the following:

- **Scalar** — Specify the input delay for a SISO system or the same delay for all inputs of a multi-input system.
- **Nu-by-1 vector** — Specify separate input delays for input of a multi-input system, where `Nu` is the number of inputs.

For continuous-time systems, specify input delays in the time unit specified by the `TimeUnit` property. For discrete-time systems, specify input delays in integer multiples of the sample time, T_s .

For more information, see “Time Delays in Linear Systems”.

OutputDelay — Output delay

0 (default) | scalar | Ny-by-1 vector

Output delay for each output channel, specified as one of the following:

- **Scalar** — Specify the output delay for a SISO system or the same delay for all outputs of a multi-output system.

- **Ny-by-1** vector — Specify separate output delays for output of a multi-output system, where **Ny** is the number of outputs.

For continuous-time systems, specify output delays in the time unit specified by the **TimeUnit** property. For discrete-time systems, specify output delays in integer multiples of the sample time, **Ts**.

For more information, see “Time Delays in Linear Systems”.

Ts — Sample time

0 (default) | positive scalar | -1

Sample time, specified as:

- 0 for continuous-time systems.
- A positive scalar representing the sampling period of a discrete-time system. Specify **Ts** in the time unit specified by the **TimeUnit** property.
- -1 for a discrete-time system with an unspecified sample time.

Note Changing **Ts** does not discretize or resample the model. To convert between continuous-time and discrete-time representations, use **c2d** and **d2c**. To change the sample time of a discrete-time system, use **d2d**.

TimeUnit — Time variable units

'seconds' (default) | 'nanoseconds' | 'microseconds' | 'milliseconds' | 'minutes' | 'hours' | 'days' | 'weeks' | 'months' | 'years' | ...

Time variable units, specified as one of the following:

- 'nanoseconds'
- 'microseconds'
- 'milliseconds'
- 'seconds'
- 'minutes'
- 'hours'
- 'days'
- 'weeks'
- 'months'
- 'years'

Changing **TimeUnit** has no effect on other properties, but changes the overall system behavior. Use **chgTimeUnit** to convert between time units without modifying system behavior.

InputName — Input channel names

'' (default) | character vector | cell array of character vectors

Input channel names, specified as one of the following:

- A character vector, for single-input models.

- A cell array of character vectors, for multi-input models.
- `''`, no names specified, for any input channels.

Alternatively, you can assign input names for multi-input models using automatic vector expansion. For example, if `sys` is a two-input model, enter the following:

```
sys.InputName = 'controls';
```

The input names automatically expand to `{'controls(1)'; 'controls(2)'}`.

You can use the shorthand notation `u` to refer to the `InputName` property. For example, `sys.u` is equivalent to `sys.InputName`.

Use `InputName` to:

- Identify channels on model display and plots.
- Extract subsystems of MIMO systems.
- Specify connection points when interconnecting models.

InputUnit — Input channel units

`''` (default) | character vector | cell array of character vectors

Input channel units, specified as one of the following:

- A character vector, for single-input models.
- A cell array of character vectors, for multi-input models.
- `''`, no units specified, for any input channels.

Use `InputUnit` to specify input signal units. `InputUnit` has no effect on system behavior.

InputGroup — Input channel groups

structure

Input channel groups, specified as a structure. Use `InputGroup` to assign the input channels of MIMO systems into groups and refer to each group by name. The field names of `InputGroup` are the group names and the field values are the input channels of each group. For example, enter the following to create input groups named `controls` and `noise` that include input channels 1 and 2, and 3 and 5, respectively.

```
sys.InputGroup.controls = [1 2];
sys.InputGroup.noise = [3 5];
```

You can then extract the subsystem from the `controls` inputs to all outputs using the following.

```
sys(:, 'controls')
```

By default, `InputGroup` is a structure with no fields.

OutputName — Output channel names

`''` (default) | character vector | cell array of character vectors

Output channel names, specified as one of the following:

- A character vector, for single-output models.

- A cell array of character vectors, for multi-output models.
- `''`, no names specified, for any output channels.

Alternatively, you can assign output names for multi-output models using automatic vector expansion. For example, if `sys` is a two-output model, enter the following.

```
sys.OutputName = 'measurements';
```

The output names automatically expand to `{'measurements(1)'; 'measurements(2)'}`.

You can also use the shorthand notation `y` to refer to the `OutputName` property. For example, `sys.y` is equivalent to `sys.OutputName`.

Use `OutputName` to:

- Identify channels on model display and plots.
- Extract subsystems of MIMO systems.
- Specify connection points when interconnecting models.

OutputUnit — Output channel units

`''` (default) | character vector | cell array of character vectors

Output channel units, specified as one of the following:

- A character vector, for single-output models.
- A cell array of character vectors, for multi-output models.
- `''`, no units specified, for any output channels.

Use `OutputUnit` to specify output signal units. `OutputUnit` has no effect on system behavior.

OutputGroup — Output channel groups

structure

Output channel groups, specified as a structure. Use `OutputGroup` to assign the output channels of MIMO systems into groups and refer to each group by name. The field names of `OutputGroup` are the group names and the field values are the output channels of each group. For example, create output groups named `temperature` and `measurement` that include output channels 1, and 3 and 5, respectively.

```
sys.OutputGroup.temperature = [1];
sys.OutputGroup.measurement = [3 5];
```

You can then extract the subsystem from all inputs to the `measurement` outputs using the following.

```
sys('measurement', :)
```

By default, `OutputGroup` is a structure with no fields.

Notes — User-specified text

`{}` (default) | character vector | cell array of character vectors

User-specified text that you want to associate with the system, specified as a character vector or cell array of character vectors. For example, `'System is MIMO'`.

UserData — User-specified data

[] (default) | any MATLAB data type

User-specified data that you want to associate with the system, specified as any MATLAB data type.

Name — System name

' ' (default) | character vector

System name, specified as a character vector. For example, 'system_1'.

SamplingGrid — Sampling grid for model arrays

structure array

Sampling grid for model arrays, specified as a structure array.

Use `SamplingGrid` to track the variable values associated with each model in a model array.

Set the field names of the structure to the names of the sampling variables. Set the field values to the sampled variable values associated with each model in the array. All sampling variables must be numeric scalars, and all arrays of sampled values must match the dimensions of the model array.

For example, you can create an 11-by-1 array of linear models, `sysarr`, by taking snapshots of a linear time-varying system at times `t = 0:10`. The following code stores the time samples with the linear models.

```
sysarr.SamplingGrid = struct('time',0:10)
```

Similarly, you can create a 6-by-9 model array, `M`, by independently sampling two variables, `zeta` and `w`. The following code maps the (`zeta,w`) values to `M`.

```
[zeta,w] = ndgrid(<6 values of zeta>,<9 values of w>)
M.SamplingGrid = struct('zeta',zeta,'w',w)
```

By default, `SamplingGrid` is a structure with no fields.

Object Functions

The following lists show functions you can use with `mechss` model objects.

Modeling

<code>sparss</code>	Sparse first-order state-space model
<code>getx0</code>	Map initial conditions from a <code>mechss</code> object to a <code>sparss</code> object
<code>full</code>	Convert sparse models to dense storage
<code>imp2exp</code>	Convert implicit linear relationship to explicit input-output relation
<code>inv</code>	Invert models
<code>getDelayModel</code>	State-space representation of internal delays

Data Access

<code>sparssdata</code>	Access first-order sparse state-space model data
<code>mechssdata</code>	Access second-order sparse state-space model data
<code>showStateInfo</code>	State vector map for sparse model
<code>spy</code>	Visualize sparsity pattern of a sparse model

Time and Frequency Response

step	Step response plot of dynamic system; step response data
impulse	Impulse response plot of dynamic system; impulse response data
initial	System response to initial states of state-space model
lsim	Plot simulated time response of dynamic system to arbitrary inputs; simulated response data
bode	Bode plot of frequency response, or magnitude and phase data
nyquist	Nyquist plot of frequency response
nichols	Nichols chart of frequency response
sigma	Singular value plot of dynamic system
passiveplot	Compute or plot passivity index as function of frequency
dcgain	Low-frequency (DC) gain of LTI system
evalfr	Evaluate system response at specific frequency
freqresp	Evaluate system response over a grid of frequencies

Model Interconnection

interface	Specify physical connections between components of mechss model
xsort	Sort states based on state partition
feedback	Feedback connection of multiple models
parallel	Parallel connection of two models
append	Group models by appending their inputs and outputs
connect	Block diagram interconnections of dynamic systems
lft	Generalized feedback interconnection of two models (Redheffer star product)
series	Series connection of two models

Examples

Continuous-Time Sparse Second-Order Model

For this example, consider the sparse matrices for the 3-D beam model subjected to an impulsive point load at its tip in the file `sparseBeam.mat`.

Extract the sparse matrices from `sparseBeam.mat`.

```
load('sparseBeam.mat','M','K','B','F','G','D');
```

Create the `mechss` model object by specifying `[]` for matrix `C`, since there is no damping.

```
sys = mechss(M,[],K,B,F,G,D)
```

Sparse continuous-time second-order model with 3 outputs, 1 inputs, and 3408 degrees of freedom.

Use `"spy"` and `"showStateInfo"` to inspect model structure.
Type `"properties('mechss')"` for a list of model properties.
Type `"help mechssOptions"` for available solver options for this model.

The output `sys` is a `mechss` model object containing a 3-by-1 array of sparse models with 3408 degrees of freedom, 1 input, and 3 outputs.

You can use the `spy` command to visualize the sparsity of the `mechss` model object.

```
spy(sys)
```

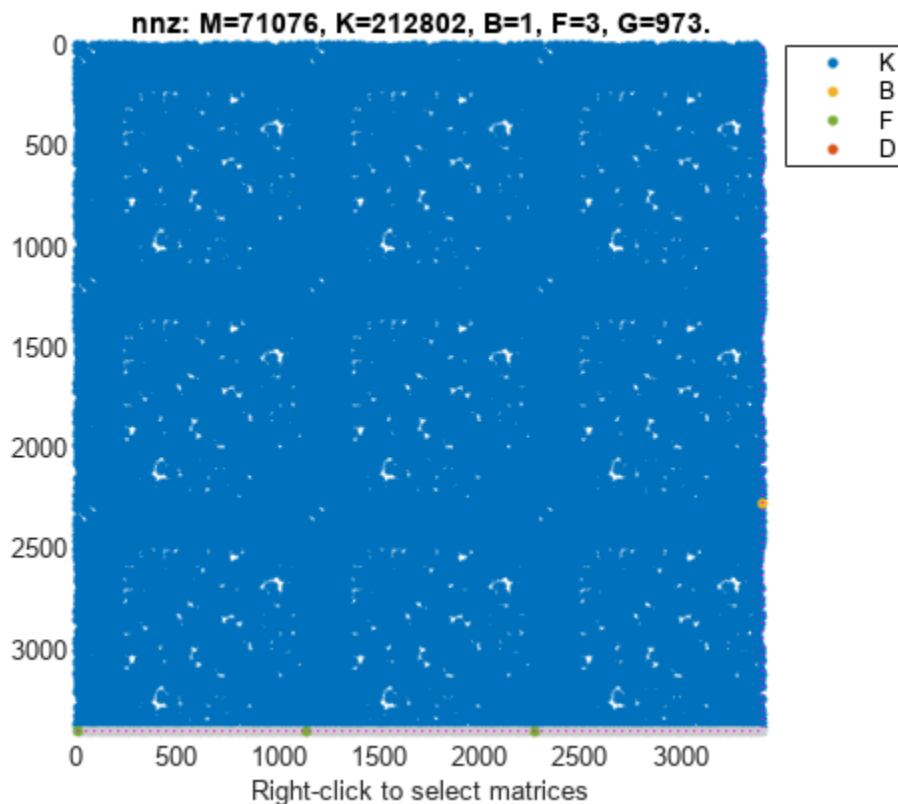

Discrete-Time Sparse Second-Order Model

For this example, consider the sparse matrices of the discrete system in the file `discreteS0Sparse.mat`.

Load the sparse matrices from `discreteS0Sparse.mat`.

```
load('discreteS0Sparse.mat', 'M', 'C', 'K', 'B', 'F', 'G', 'D', 'ts');
```

Create the discrete-time `mechss` model object by specifying the sample time `ts`.

```
sys = mechss(M,C,K,B,F,G,D,ts)
```

Sparse discrete-time second-order model with 1 outputs, 1 inputs, and 28408 degrees of freedom.

Use `"spy"` and `"showStateInfo"` to inspect model structure.

Type `"properties('mechss')"` for a list of model properties.

Type `"help mechssOptions"` for available solver options for this model.

The output `sys` is a discrete-time `mechss` model object with 28408 degrees of freedom, 1 input, and 1 output.

You can use the `spy` command to visualize the sparsity pattern of the `mechss` model object. You can right-click on the plot to select matrices to be displayed.

```
spy(sys)
```

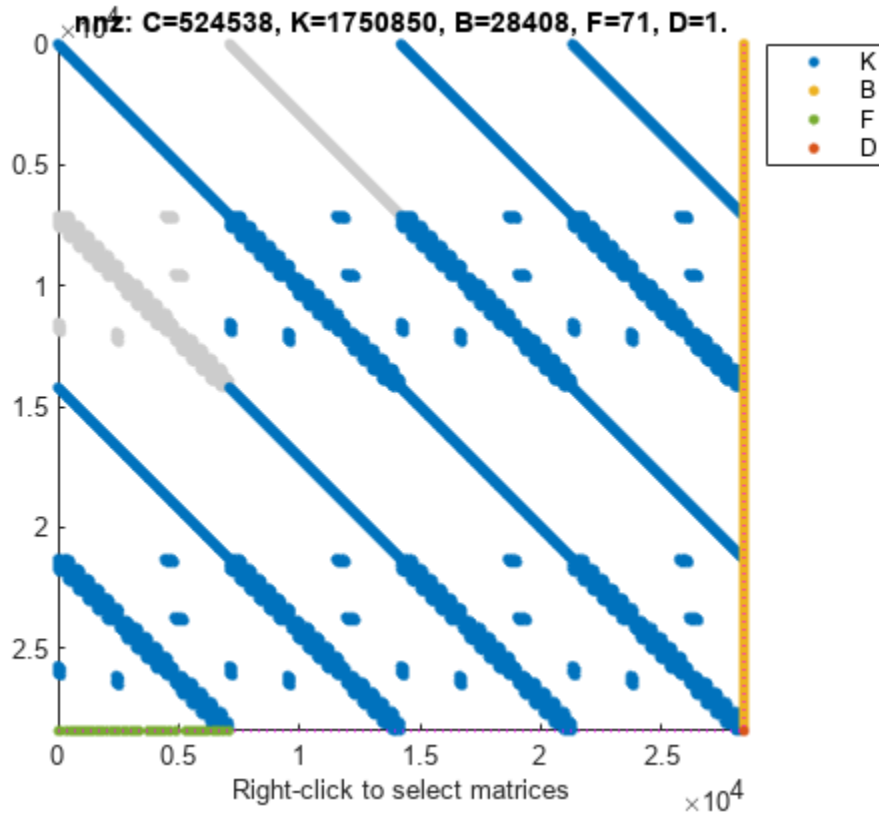

Array of Sparse Second-Order Models

For this example, consider `sparseSOArray.mat` which contains three sets of sparse matrices that define multiple sparse second-order state-space models.

Extract the data from `sparseSOArray.mat`.

```
load('sparseSOArray.mat');
```

Preallocate a 3-by-1 array of `mehss` models.

```
sys = mehss(zeros(1,1,3));
```

Next, use indexed assignment to populate the 3-by-1 array with sparse second-order models.

```
sys(:,:,1) = mehss(M1,[],K1,B1,F1,G1,[]);
sys(:,:,2) = mehss(M2,[],K2,B2,F2,G2,[]);
sys(:,:,3) = mehss(M3,[],K3,B3,F3,G3,[]);
size(sys)
```

3x1 array of sparse second-order models.

Each model has 1 outputs, 1 inputs, and between 385 and 738 degrees of freedom.

Alternatively, you can also create an array of sparse second-order models using the `stack` command when you have models with the same I/O sizes.

Copyright 2020 The MathWorks, Inc

MIMO Static Gain Sparse Second-Order Model

Create a static gain MIMO sparse second-order state-space model.

Consider the following two-input, three-output static gain matrix:

$$D = \begin{bmatrix} 1 & 5 \\ 2 & 3 \\ 5 & 9 \end{bmatrix}$$

Specify the gain matrix and create the static gain sparse second-order state-space model.

```
D = [1,5;2,3;5,9];
sys = mechss(D);
size(sys)
```

Sparse second-order model with 3 outputs, 2 inputs, and 0 degrees of freedom.

Mass-Spring-Damper Sparse Second-Order Model

For this example, consider `sparseS0Signal.mat` which contains the mass, stiffness, and damping sparse matrices.

Load the sparse matrices from `sparseS0Signal.mat` and create the sparse second-order model object.

```
load('sparseS0Model.mat', 'M', 'C', 'K');
sys = mechss(M,C,K);
```

`mechss` creates the model object `sys` with the following assumptions:

- Identity matrices for B and F with the same size as mass matrix M.
- Zero matrices for G and D.

Convert First-Order Sparse Model to Second-Order Sparse Model Representation

For this example, consider `sparssModel.mat` that contains a `sparss` model object `ltiSys`.

Load the `sparss` model object from `sparssModel.mat`.

```
load('sparssModel.mat', 'ltiSys');
ltiSys
```

Sparse continuous-time state-space model with 1 outputs, 1 inputs, and 354 states.

Use "spy" and "showStateInfo" to inspect model structure.
Type "properties('sparss')" for a list of model properties.
Type "help sparssOptions" for available solver options for this model.

Use the `mechss` command to convert to `mechss` model object representation.

```
sys = mechss(ltiSys)
```

Sparse continuous-time second-order model with 1 outputs, 1 inputs, and 354 degrees of freedom.

Use "spy" and "showStateInfo" to inspect model structure.
Type "properties('mechss')" for a list of model properties.
Type "help mechssOptions" for available solver options for this model.

Time and Frequency Response of Sparse Second-Order Model

For this example, consider `tuningForkData.mat` that contains the sparse second-order model of a tuning fork being struck gently but quickly on one of its tines. The system has one input, the pressure applied on one of its tines, which results in two outputs - the displacements at the tip and base of the tuning fork.

Load the sparse matrices from `tuningForkData.mat` into the workspace and create the `mechss` model object.

```
load('tuningForkData.mat','M','K','B','F');  
sys = mechss(M,[],K,B,F,'InputName','pressure','Outputname',{'y tip','x base'})
```

Next, set solver options for the model by setting the `UseParallel` parameter to `true` and the `DAESolver` to use `trbdf3`. Use `spy` to inspect the model structure. Enabling parallel computing requires a Parallel Computing Toolbox™ license.

```
sys.SolverOptions.UseParallel = true;  
sys.SolverOptions.DAESolver = 'trbdf3';  
spy(sys)
```

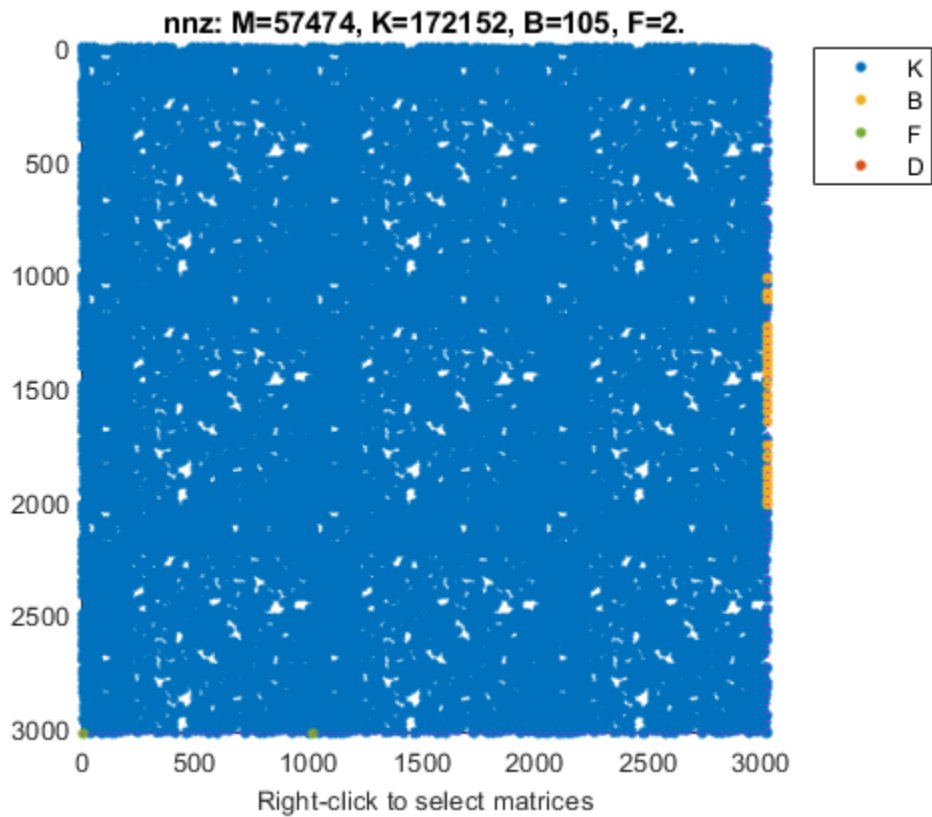

You can also use `showStateInfo` to examine the components.

```
showStateInfo(sys)
```

Use `step` to obtain the step response plot of the system. You need to provide the time vector or final time for sparse models.

```
t = linspace(0,0.5,1000);  
step(sys,t)
```

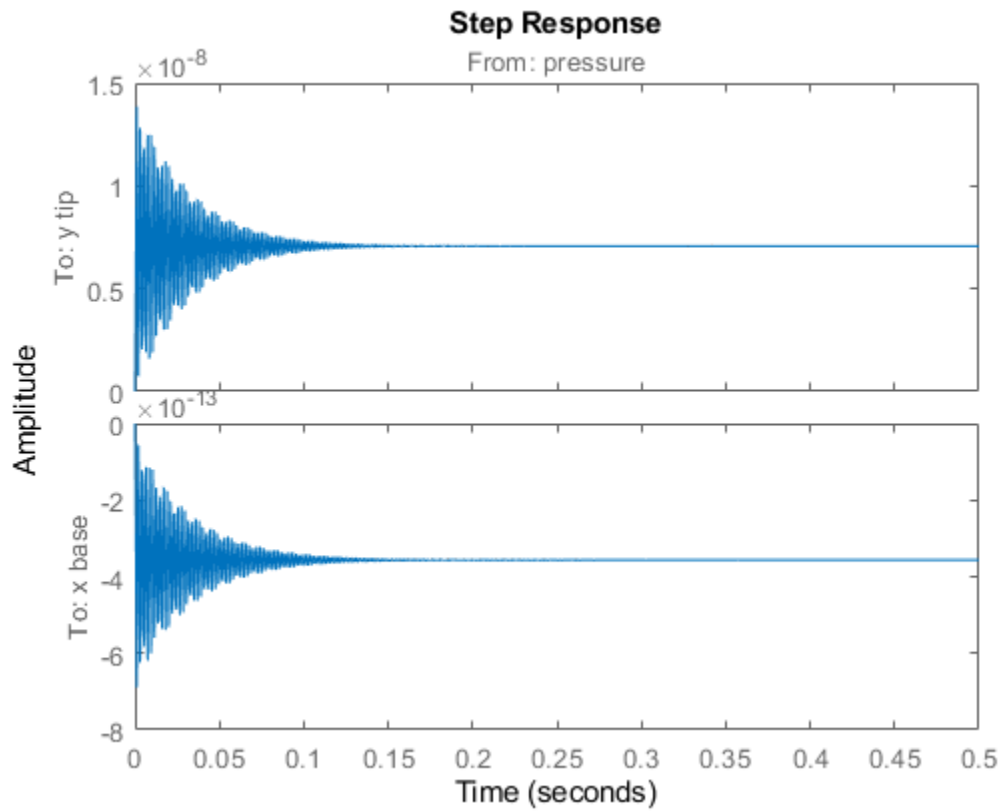

Next, obtain the Bode plot to examine the frequency response. You need to provide the frequency vector for sparse models.

```
w = logspace(1,5,1000);  
bode(sys,w), grid
```

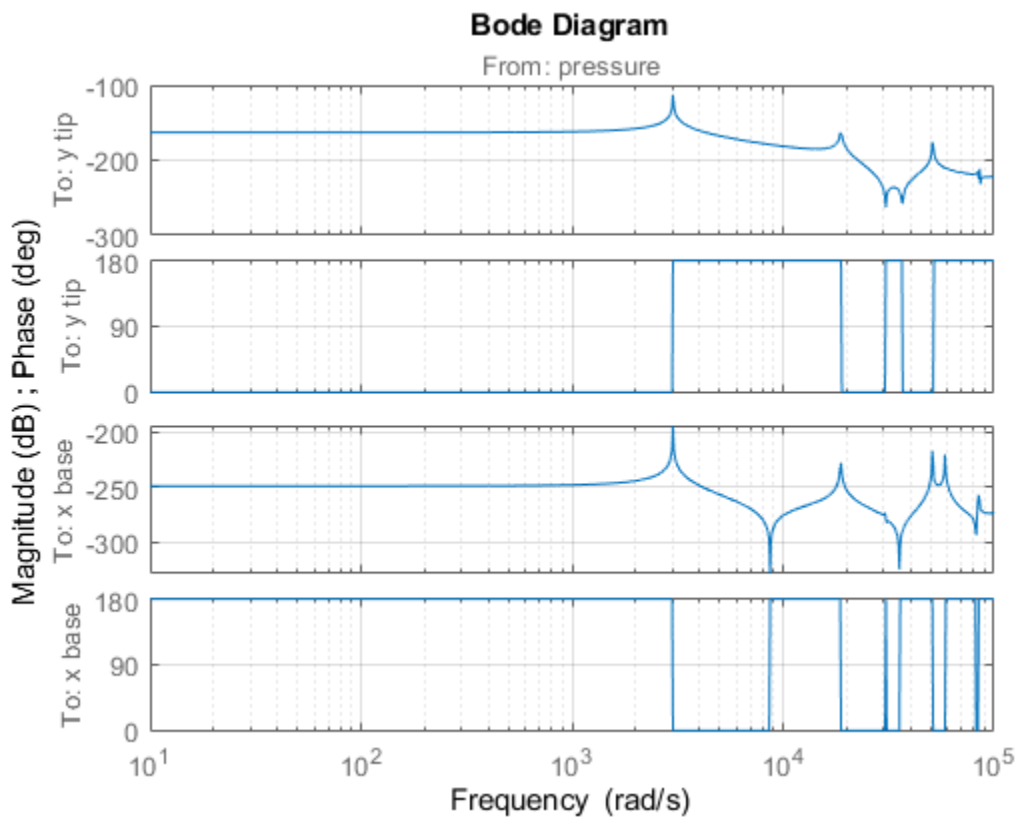

Sparse Second-Order Model in a Feedback Loop

For this example, consider `sparseS0Signal.mat` that contains a sparse second-order model. Define an actuator, sensor, and controller and connect them together with the plant in a feedback loop.

Load the sparse matrices and create the `mechss` object.

```
load sparseS0Signal.mat
plant = mechss(M,C,K,B,F,[],[], 'Name', 'Plant');
```

Next, create an actuator and sensor using transfer functions.

```
act = tf(1,[1 0.5 3], 'Name', 'Actuator');
sen = tf(1,[0.02 7], 'Name', 'Sensor');
```

Create a PID controller object for the plant.

```
con = pid(1,1,0.1,0.01, 'Name', 'Controller');
```

Use the `feedback` command to connect the plant, sensor, actuator, and controller in a feedback loop.

```
sys = feedback(sen*plant*act*con,1)
```

Sparse continuous-time second-order model with 1 outputs, 1 inputs, and 7111 degrees of freedom.

Use "spy" and "showStateInfo" to inspect model structure.
Type "properties('mechss')" for a list of model properties.
Type "help mechssOptions" for available solver options for this model.

The resultant system `sys` is a `mechss` object since `mechss` objects take precedence over all other model object types.

Use `showStateInfo` to view the component and signal groups.

```
showStateInfo(sys)
```

The state groups are:

Type	Name	Size
Component	Sensor	1
Component	Plant	7102
Signal		1
Component	Actuator	2
Signal		1
Component	Controller	2
Signal		1
Signal		1

Use `xsort` to sort the components and signals, and then view the component and signal groups.

```
sysSort = xsort(sys);  
showStateInfo(sysSort)
```

The state groups are:

Type	Name	Size
Component	Sensor	1
Component	Plant	7102
Component	Actuator	2
Component	Controller	2
Signal		4

Observe that the components are now ordered before the signal partition. The signals are now sorted and grouped together in a single partition.

You can also visualize the sparsity pattern of the resultant system using `spy`.

```
spy(sysSort)
```

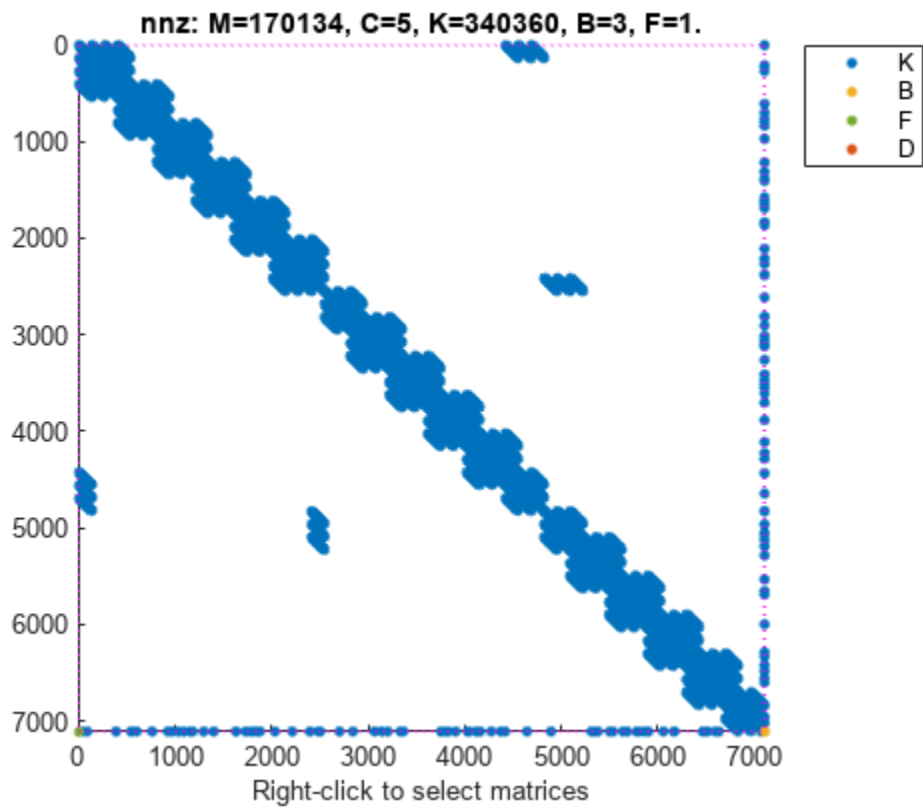

Physical Connections Between Components in Sparse Second-Order Model

For this example, consider a structural model that consists of two square plates connected with pillars at each vertex as depicted in the figure below. The lower plate is attached rigidly to the ground while the pillars are attached rigidly to each vertex of the square plate.

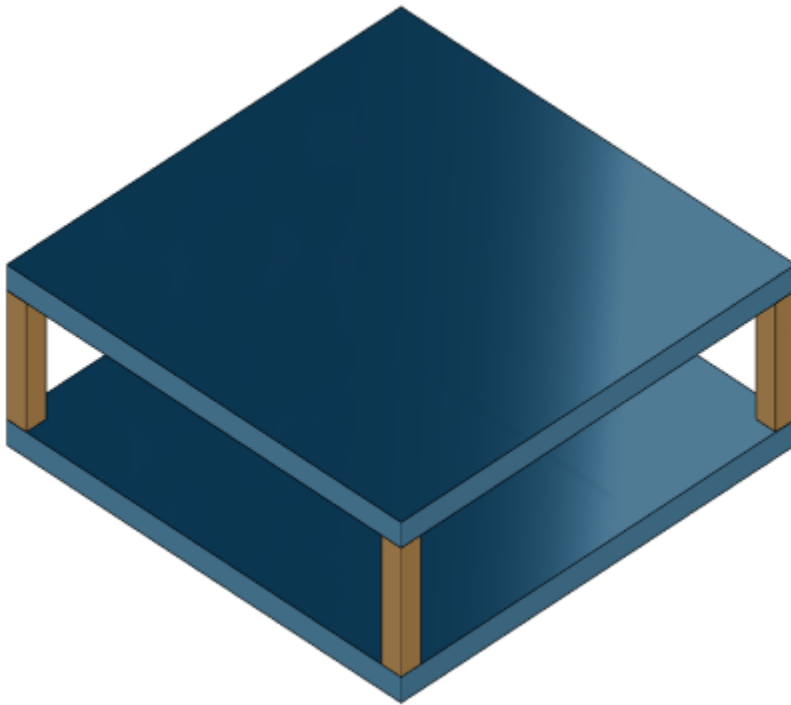

Load the finite element model matrices contained in `platePillarModel.mat` and create the sparse second-order model representing the above system.

```
load('platePillarModel.mat')
model = ...
    mechss(M1,[],K1,B1,F1,'Name','Plate1') + ...
    mechss(M2,[],K2,B2,F2,'Name','Plate2') + ...
    mechss(Mp,[],Kp,Bp,Fp,'Name','Pillar3') + ...
    mechss(Mp,[],Kp,Bp,Fp,'Name','Pillar4') + ...
    mechss(Mp,[],Kp,Bp,Fp,'Name','Pillar5') + ...
    mechss(Mp,[],Kp,Bp,Fp,'Name','Pillar6');
sys = model;
```

Use `showStateInfo` to examine the components of the `mechss` model object.

```
showStateInfo(sys)
```

The state groups are:

Type	Name	Size
Component	Plate1	2646
Component	Plate2	2646
Component	Pillar3	132
Component	Pillar4	132
Component	Pillar5	132
Component	Pillar6	132

Now, load the interfaced degree of freedom (DOF) index data from `dofData.mat` and use `interface` to create the physical connections between the two plates and the four pillars. `dofs` is a 6x7 cell array where the first two rows contain DOF index data for the first and second plates while the remaining four rows contain index data for the four pillars. By default, the function uses dual-assembly method of physical coupling.

```
load('dofData.mat','dofs')
for i=3:6
    sys = interface(sys,"Plate1",dofs{1,i},"Pillar"+i,dofs{i,1});
    sys = interface(sys,"Plate2",dofs{2,i},"Pillar"+i,dofs{i,2});
end
```

Specify connection between the bottom plate and the ground.

```
sysConDual = interface(sys,"Plate2",dofs{2,7});
```

Use `showStateInfo` to confirm the physical interfaces.

```
showStateInfo(sysConDual)
```

The state groups are:

Type	Name	Size
-----	-----	-----
Component	Plate1	2646
Component	Plate2	2646
Component	Pillar3	132
Component	Pillar4	132
Component	Pillar5	132
Component	Pillar6	132
Interface	Plate1-Pillar3	12
Interface	Plate2-Pillar3	12
Interface	Plate1-Pillar4	12
Interface	Plate2-Pillar4	12
Interface	Plate1-Pillar5	12
Interface	Plate2-Pillar5	12
Interface	Plate1-Pillar6	12
Interface	Plate2-Pillar6	12
Interface	Plate2-Ground	6

You can use `spy` to visualize the sparse matrices in the final model.

```
spy(sysConDual)
```

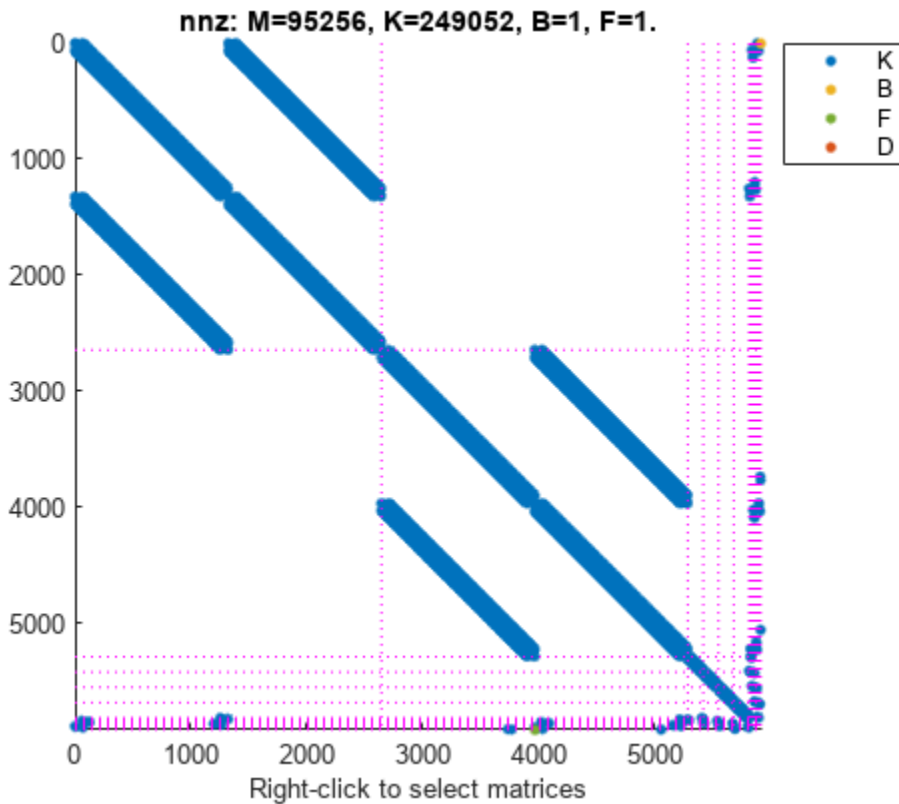

Now, specify physical connections using the primal-assembly method.

```
sys = model;
for i=3:6
    sys = interface(sys, "Plate1",dofs{1,i}, "Pillar"+i,dofs{i,1}, 'primal');
    sys = interface(sys, "Plate2",dofs{2,i}, "Pillar"+i,dofs{i,2}, 'primal');
end
sysConPrimal = interface(sys, "Plate2",dofs{2,7}, 'primal');
```

Use `showStateInfo` to confirm the physical interfaces.

```
showStateInfo(sysConPrimal)
```

The state groups are:

Type	Name	Size
Component	Plate1	2646
Component	Plate2	2640
Component	Pillar3	108
Component	Pillar4	108
Component	Pillar5	108
Component	Pillar6	108

Primal assembly eliminates half of the redundant DOFs associated with the shared set of DOFs in the global finite element mesh.

You can use `spy` to visualize the sparse matrices in the final model.

```
spy(sysConPrimal)
```

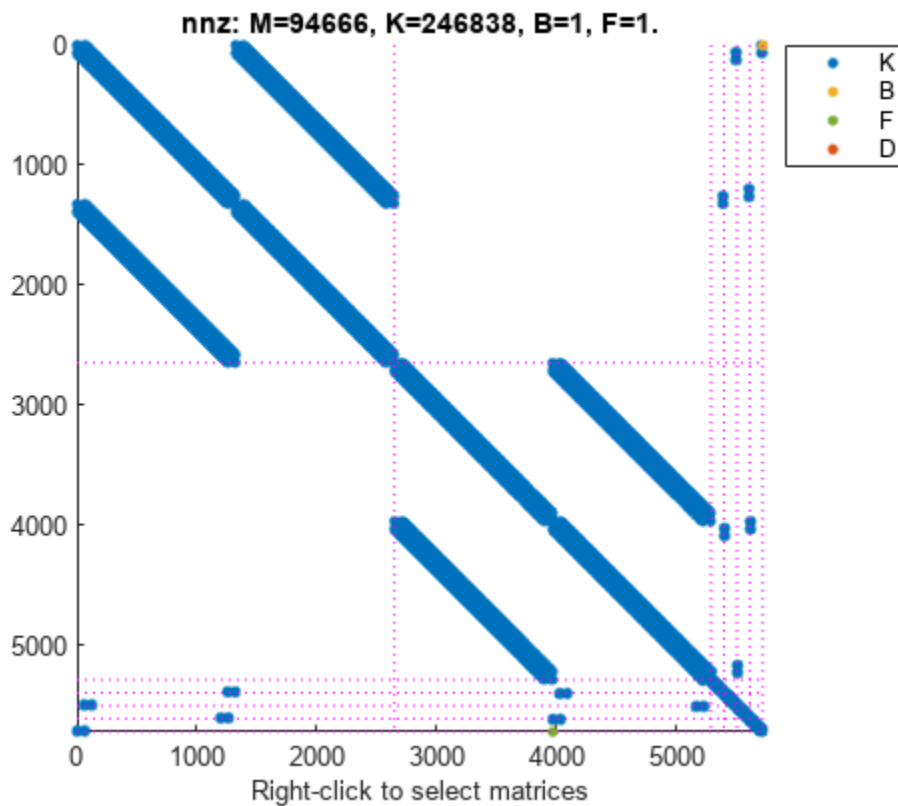

The data set for this example was provided by Victor Dolk from ASML.

Version History

Introduced in R2020b

References

- [1] H. Hilber, T. Hughes & R. Taylor. "Improved numerical dissipation for time integration algorithms in structural dynamics." *Earthquake Engineering and Structural Dynamics*, vol. 5, no. 3, pp. 283-292, 1977.
- [2] M. Hosea and L. Shampine. "Analysis and implementation of TR-BDF2." *Applied Numerical Mathematics*, vol. 20, no. 1-2, pp. 21-37, 1996.

See Also

[spars](#) | [mechssdata](#) | [showStateInfo](#) | [interface](#) | [xsort](#) | [full](#) | [spy](#) | Sparse Second Order

Topics

"Rigid Assembly of Model Components"
 "Linear Analysis of Cantilever Beam"

“Sparse Model Basics”

mechssdata

Access second-order sparse state-space model data

Syntax

```
[M,C,K,B,F,G,D] = mechssdata(sys)
[M,C,K,B,F,G,D,ts] = mechssdata(sys)
___ = mechssdata(sys,J1,...,JN)
```

Description

`[M,C,K,B,F,G,D] = mechssdata(sys)` returns the M, C, K, B, F, G and D matrices of the sparse state-space model `sys`. If `sys` is not a mechss model, it is first converted to mechss model form.

When your system has internal delays, `mechssdata` returns the matrices for `pade(sys,0)`, which involves feedback loops around the internal delays and the model is retained in differential algebraic equation (DAE). As a result, the size of matrices M, C, and K are typically larger than the order of `sys` since they are augmented by the feedback signals to preserve sparsity.

`[M,C,K,B,F,G,D,ts] = mechssdata(sys)` also returns the sample time `ts`.

`___ = mechssdata(sys,J1,...,JN)` extracts the data for the `J1,...,JN` entry in the model array `sys`.

Examples

Extract Continuous-Time Sparse Second-Order State-Space Model Data

For this example, consider `sparseSOModels.mat` which contains a continuous-time mechss model `sys1`.

Load the model `sys1` to the workspace and use `mechssdata` to extract the sparse matrices.

```
load('sparseSOModels.mat','sys1');
size(sys1)
```

Sparse second-order model with 2 outputs, 2 inputs, and 299 degrees of freedom.

```
[M,C,K,B,F,G,D] = mechssdata(sys1);
```

The matrices are returned as arrays of sparse doubles.

Extract Discrete-Time Sparse Second-Order State-Space Model Data

For this example, consider `sparseSOModels.mat` which contains a discrete-time mechss model `sys2`.

Load the model `sys2` to the workspace and use `mechssdata` to extract the sparse matrices.

```
load('sparseS0Models.mat','sys2');
size(sys2)
```

Sparse second-order model with 3 outputs, 3 inputs, and 108 degrees of freedom.

```
[M,C,K,B,F,G,D,ts] = mechssdata(sys2);
```

The matrices are returned as arrays of sparse doubles.

Extract Data from Specific Model in Sparse Second-Order Model Array

For this example, extract sparse matrices for a specific sparse second-order state-space model contained in the 3x1 array of sparse second-order models `sys`.

Load the data and extract the sparse matrices of the second model in the array.

```
load('sparseS0ModelArray.mat','sys');
size(sys)
```

1x3 array of sparse second-order models.
Each model has 1 outputs, 3 inputs, and 1174 degrees of freedom.

```
[M,C,K,B,F,G,D] = mechssdata(sys,1,2);
```

Input Arguments

sys — Dynamic system

dynamic system model | model array

Dynamic system, specified as a SISO or MIMO dynamic system model, or an array of SISO or MIMO dynamic system models. Dynamic systems that you can use include continuous-time or discrete-time numeric LTI models such as `mechss`, `sparss`, `tf`, `ss` and `zpk` models.

If `sys` is not a `mechss` model object, it is first converted to a second-order sparse state-space model using `mechss`. For more information on the format of the second-order sparse state-space model data, see the `mechss` reference page.

J1, . . . , JN — Indices of models in array whose data you want to access

positive integer

Indices of models in array whose data you want to access, specified as a positive integer. You can provide as many indices as there are array dimensions in `sys`. For example, if `sys` is a 4-by-5 array of sparse models, the following command accesses the data for entry (2,3) in the array.

```
[M,C,K,B,F,G,D] = mechssdata(sys,2,3);
```

Output Arguments

M — Mass matrix

N_q -by- N_q sparse matrix

Mass matrix, returned as an N_q -by- N_q sparse matrix where, N_q is the number of nodes.

C – Damping matrix

Nq-by-Nq sparse matrix

Damping matrix, returned as an Nq-by-Nq sparse matrix where, Nq is the number of nodes.

K – Stiffness matrix

Nq-by-Nq sparse matrix

Stiffness matrix, returned as an Nq-by-Nq sparse matrix where, Nq is the number of nodes.

B – Input-to-state matrix

Nq-by-Nu sparse matrix

Input-to-state matrix, returned as an Nq-by-Nu sparse matrix where, Nq is the number of nodes and Nu is the number of inputs.

F – Displacement-to-output matrix

Ny-by-Nq sparse matrix

Displacement-to-output matrix, returned as an Ny-by-Nq sparse matrix where, Nq is the number of nodes and Ny is the number of outputs.

G – Velocity-to-output matrix

Ny-by-Nq sparse matrix

Velocity-to-output matrix, returned as an Ny-by-Nq sparse matrix where, Nq is the number of nodes and Ny is the number of outputs.

D – Input-to-output matrix

Ny-by-Nu sparse matrix

Input-to-output matrix, returned as an Ny-by-Nu sparse matrix where, Ny is the number of outputs and Nu is the number of inputs. D is also called as the static gain matrix which represents the ratio of the output to the input under steady state condition.

ts – Sample time

scalar

Sample time, returned as a scalar.

Version History

Introduced in R2020b

See Also

mechss

Topics

“Sparse Model Basics”

minreal

Minimal realization or pole-zero cancellation

Syntax

```
sysr = minreal(sys)
sysr = minreal(sys,tol)
[sysr,u] = minreal(sys,tol)
... = minreal(sys,tol,false)
... = minreal(sys,[],false)
```

Description

`sysr = minreal(sys)` eliminates uncontrollable or unobservable state in state-space models, or cancels pole-zero pairs in transfer functions or zero-pole-gain models. The output `sysr` has minimal order and the same response characteristics as the original model `sys`.

`sysr = minreal(sys,tol)` specifies the tolerance used for state elimination or pole-zero cancellation. The default value is `tol = sqrt(eps)` and increasing this tolerance forces additional cancellations.

`[sysr,u] = minreal(sys,tol)` returns, for state-space model `sys`, an orthogonal matrix `U` such that (U^*A^*U', U^*B, C^*U') is a Kalman decomposition of (A,B,C)

`... = minreal(sys,tol,false)` and `... = minreal(sys,[],false)` disable the verbose output of the function. By default, `minreal` displays a message indicating the number of states removed from a state-space model `sys`.

Examples

The commands

```
g = zpk([],1,1);
h = tf([2 1],[1 0]);
cloop = inv(1+g*h) * g
```

produce the nonminimal zero-pole-gain model `cloop`.

`cloop =`

$$\frac{s (s-1)}{(s-1) (s^2 + s + 1)}$$

Continuous-time zero/pole/gain model.

To cancel the pole-zero pair at $s = 1$, type

```
cloopmin = minreal(cloop)
```

This command produces the following result.

cloopmin =

$$\frac{s}{s^2 + s + 1}$$

Continuous-time zero/pole/gain model.

Algorithms

Pole-zero cancellation is a straightforward search through the poles and zeros looking for matches that are within tolerance. Transfer functions are first converted to zero-pole-gain form.

Alternative Functionality

App

Model Reducer

Live Editor Task

Reduce Model Order

Version History

Introduced before R2006a

See Also

Model Reducer | balreal | modred | sminreal

Topics

"Pole-Zero Simplification"

"Model Reduction Basics"

modred

Eliminate states from state-space models

Syntax

```
rsys = modred(sys,elim)
rsys = modred(sys,elim,'method')
```

Description

`rsys = modred(sys,elim)` reduces the order of a continuous or discrete state-space model `sys` by eliminating the states found in the vector `elim`. The full state vector X is partitioned as $X = [X1;X2]$ where $X1$ is the reduced state vector and $X2$ is discarded.

`elim` can be a vector of indices or a logical vector commensurate with X where true values mark states to be discarded. This function is usually used in conjunction with `balreal`. Use `balreal` to first isolate states with negligible contribution to the I/O response. If `sys` has been balanced with `balreal` and the vector `g` of Hankel singular values has M small entries, you can use `modred` to eliminate the corresponding M states. For example:

```
[sys,g] = balreal(sys) % Compute balanced realization
elim = (g<1e-8) % Small entries of g are negligible states
rsys = modred(sys,elim) % Remove negligible states
```

`rsys = modred(sys,elim,'method')` also specifies the state elimination method. Choices for 'method' include

- 'MatchDC' (default): Enforce matching DC gains. The state-space matrices are recomputed as described in "Algorithms" on page 2-754.
- 'Truncate': Simply delete $X2$.

The 'Truncate' option tends to produce a better approximation in the frequency domain, but the DC gains are not guaranteed to match.

If the state-space model `sys` has been balanced with `balreal` and the grammians have m small diagonal entries, you can reduce the model order by eliminating the last m states with `modred`.

Examples

Order Reduction by Matched-DC-Gain and Direct-Deletion Methods

Consider the following continuous fourth-order model.

$$h(s) = \frac{s^3 + 11s^2 + 36s + 26}{s^4 + 14.6s^3 + 74.96s^2 + 153.7s + 99.65}$$

To reduce its order, first compute a balanced state-space realization with `balreal`.

```
h = tf([1 11 36 26],[1 14.6 74.96 153.7 99.65]);
[hb,g] = balreal(h);
```

Examine the gramians.

`g'`

```
ans = 1x4
```

```
    0.1394    0.0095    0.0006    0.0000
```

The last three diagonal entries of the balanced gramians are relatively small. Eliminate these three least-contributing states with `modred`, using both matched-DC-gain and direct-deletion methods.

```
hmdc = modred(hb,2:4,'MatchDC');
hdel = modred(hb,2:4,'Truncate');
```

Both `hmdc` and `hdel` are first-order models. Compare their Bode responses against that of the original model.

```
bodeplot(h, '-', hmdc, 'x', hdel, '*')
```

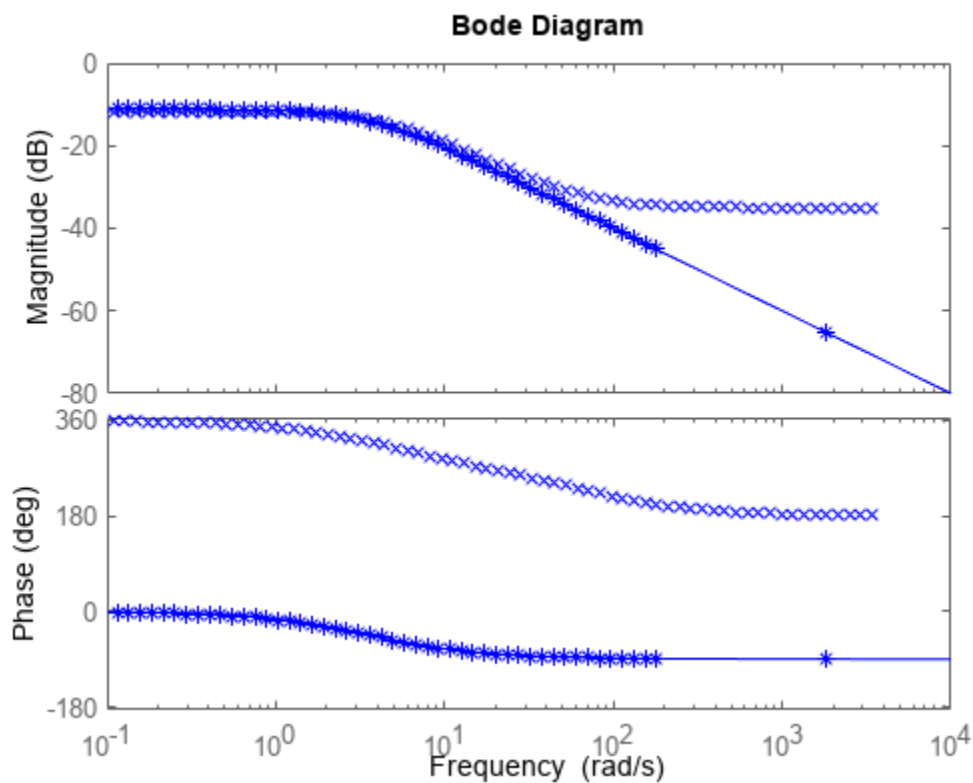

The reduced-order model `hdel` is clearly a better frequency-domain approximation of `h`. Now compare the step responses.

```
stepplot(h, '-', hmdc, '-.', hdel, '---')
```

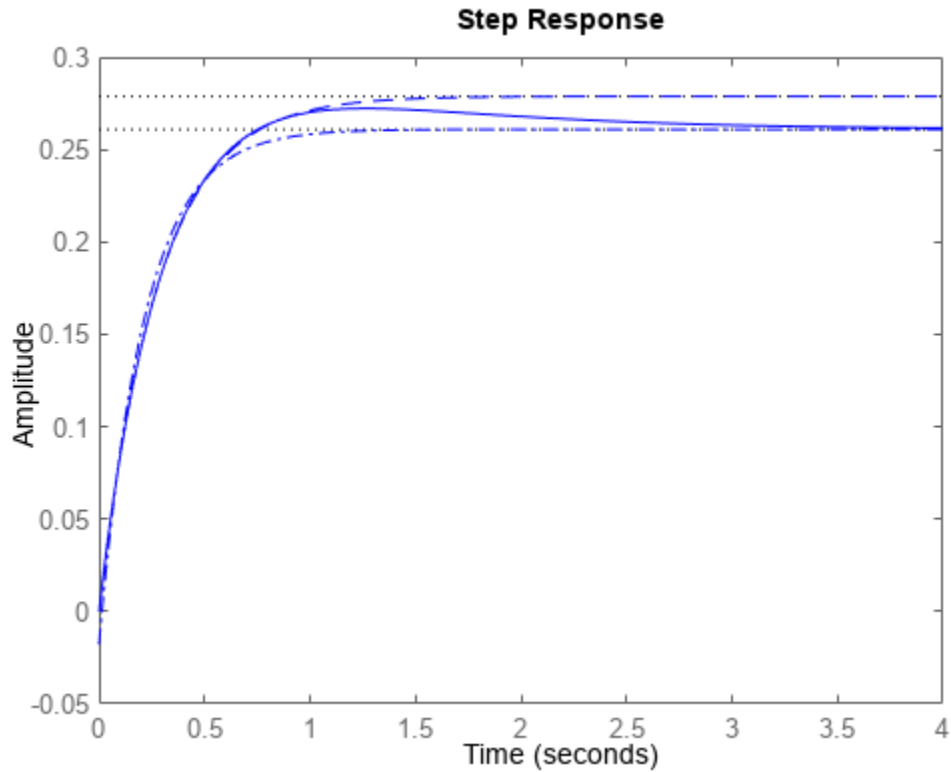

While `hdel` accurately reflects the transient behavior, only `hmdc` gives the true steady-state response.

Algorithms

The algorithm for the matched DC gain method is as follows. For continuous-time models

$$\begin{aligned} \dot{x} &= Ax + By \\ y &= Cx + Du \end{aligned}$$

the state vector is partitioned into x_1 , to be kept, and x_2 , to be eliminated.

$$\begin{aligned} \begin{bmatrix} \dot{x}_1 \\ \dot{x}_2 \end{bmatrix} &= \begin{bmatrix} A_{11} & A_{12} \\ A_{21} & A_{22} \end{bmatrix} \begin{bmatrix} x_1 \\ x_2 \end{bmatrix} + \begin{bmatrix} B_1 \\ B_2 \end{bmatrix} u \\ y &= [C_1 \ C_2]x + Du \end{aligned}$$

Next, the derivative of x_2 is set to zero and the resulting equation is solved for x_1 . The reduced-order model is given by

$$\begin{aligned} \dot{x}_1 &= [A_{11} - A_{12}A_{22}^{-1}A_{21}]x_1 + [B_1 - A_{12}A_{22}^{-1}B_2]u \\ y &= [C_1 - C_2A_{22}^{-1}A_{21}]x_1 + [D - C_2A_{22}^{-1}B_2]u \end{aligned}$$

The discrete-time case is treated similarly by setting

$$x_2[n+1] = x_2[n]$$

Version History

Introduced before R2006a

See Also

balreal | minreal | balred

Model Reducer

Reduce complexity of linear time-invariant (LTI) models

Description

The **Model Reducer** app lets you compute reduced-order approximations of high-order models. Working with lower-order models can simplify analysis and control design. Simpler models are also easier to understand and manipulate. You can reduce a plant model to focus on relevant dynamics before designing a controller for the plant. Or, you can use model reduction to simplify a full-order controller.

Using any of the following methods, **Model Reducer** helps you reduce model order while preserving model characteristics that are important to your application:

- Balanced Truncation — Remove states with relatively small energy contributions.
- Mode Selection — Select modes by specifying a frequency range of interest.
- Pole-Zero Simplification — Eliminate canceling or near-canceling pole-zero pairs.

Model Reducer provides response plots and error plots to help ensure that the reduced-order model preserves important dynamics. For more information on model reduction and why it is useful, see “Model Reduction Basics”.

For an alternative to the **Model Reducer** app that lets you interactively perform model reduction and generate code for a live script, see the Reduce Model Order task in the Live Editor.

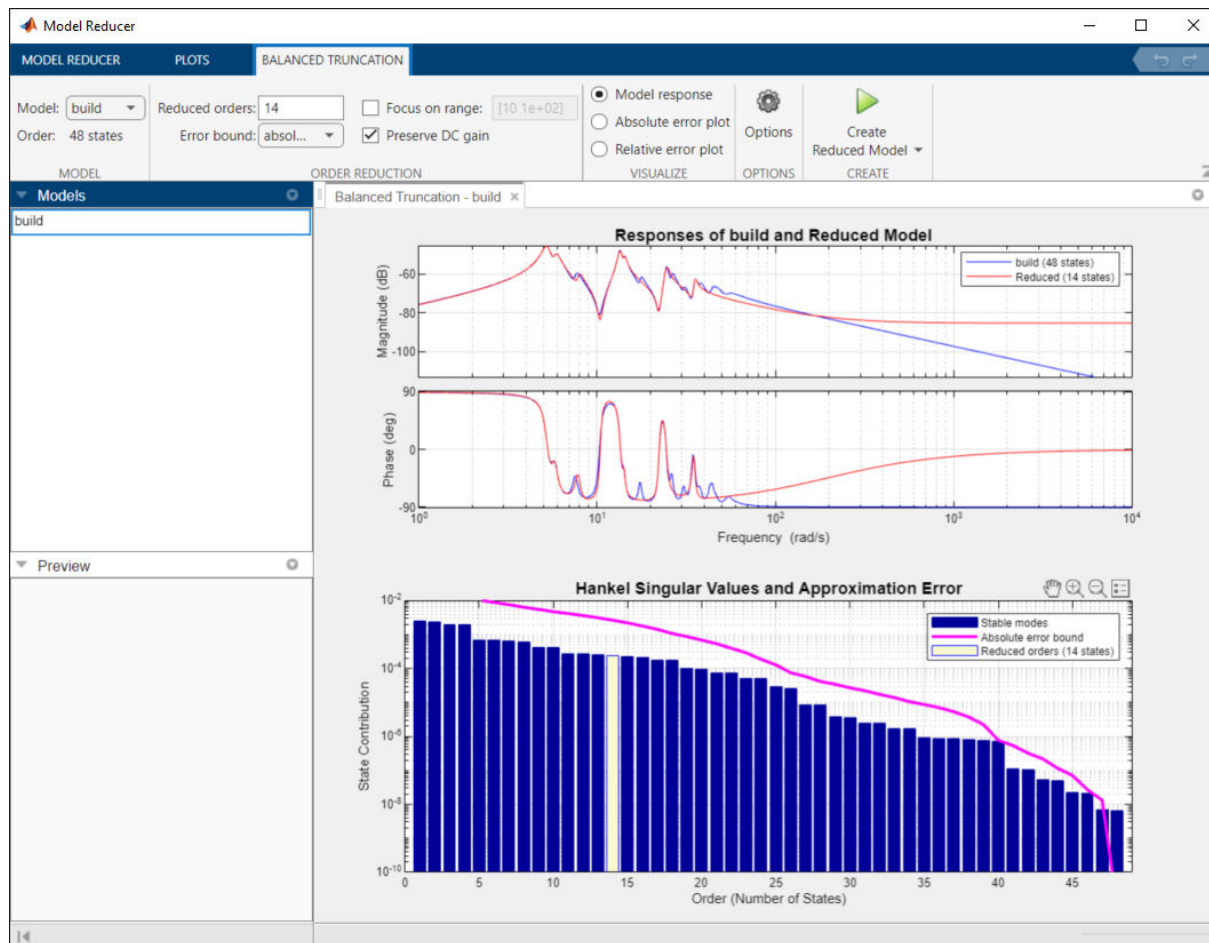

Open the Model Reducer App

- MATLAB Toolstrip: On the **Apps** tab, under **Control System Design and Analysis**, click the app icon.
- MATLAB command prompt: Enter `modelReducer`.

Examples

- "Model Reduction Basics"
- "Reduce Model Order Using the Model Reducer App"
- "Balanced Truncation Model Reduction"
- "Pole-Zero Simplification"
- "Mode-Selection Model Reduction"

Parameters

Balanced Truncation Tab

Model — Currently selected model for reduction

model name

Specify the model you want to reduce by selecting from the **Model** drop-down list. The list includes all models currently in the data browser. To get a model from the MATLAB workspace into the data

browser, on the **Model Reducer** tab, click  **Import Model**. You can import any:

- `tf`, `ss`, or `zpk` model that is proper. The model can be SISO or MIMO, and continuous or discrete.
 - Continuous-time models must not have time delays. To reduce a continuous-time model with time delays, first use `pade` to approximate the time delays as model dynamics.
 - Discrete-time models can have time delays. For the Balanced Truncation reduction method, the app uses `absorbDelay` to convert the delay into poles at $z = 0$ before reducing the model. The additional states are reflected in the response plot and Hankel singular-value plot.
- Generalized model such as a `genss` model. The **Model Reducer** app uses the current or nominal value of all control design blocks in `model` (see `getValue`).

Note Model Reducer assumes that the model time unit (specified in the `TimeUnit` property of the model) is seconds. If your model does not have `TimeUnit = 'seconds'`, use `chgTimeUnit` to convert the model to seconds.

Reduced orders — Number of states in reduced model

integer | integer array

Specify the number of states in the reduced-order model. Any value is permitted that falls between the number of unstable states in the model and the number of states in the original model. If you specify a single value, **Model Reducer** computes and displays the responses of a model of that order. If you specify multiple values, **Model Reducer** computes models of all specified orders and displays their responses on the same plot. To store reduced models in the data browser, click .

For more information, see “Balanced Truncation Model Reduction”.

Example: 5

Example: 4:7

Example: [3,7,10]

Error Bound — Type of error bound

absolute (default) | relative

You can choose between absolute and relative errors by selecting the appropriate option in **Error Bound**. Setting it to `absolute` controls the absolute error $\|G - G_r\|_\infty$ while setting it to `relative` controls the relative error $\|G^{-1}(G - G_r)\|_\infty$. Relative error gives a better match across frequency while absolute error emphasizes areas with most gain.

For more information, see “Balanced Truncation Model Reduction”.

Preserve DC Gain — Match DC gain of reduced model to original model

checked (default) | unchecked

When **Preserve DC Gain** is checked, the DC gain of the reduced model equals the DC gain of the original model. When the DC behavior of the model is important in your application, leave this option checked. Uncheck the option to get better matching of higher-frequency behavior.

For more information, see “Balanced Truncation Model Reduction”.

Focus on range — Limit analysis to specified frequencies

unchecked (default) | checked

By default, **Model Reducer** analyzes Hankel singular values across all frequencies. Restricting this analysis to a particular frequency range is useful when you know the model has modes outside the region of interest to your particular application. When you apply a frequency limit, **Model Reducer** determines which states are the low-energy states to truncate based on their energy contribution within the specified frequency range only. **Focus on range** is only available when **Error Bound** is set to **absolute**.

To limit the analysis of state contributions to a particular frequency range, check **Focus on range**. Then, drag the vertical cursors on the response plot to specify the frequency range of interest. Alternatively, enter a frequency range in the text box as a vector of the form `[fmin, fmax]`. Units are rad/TimeUnit, where TimeUnit is the TimeUnit property of the model you are reducing.

Mode Selection Tab**Model — Currently selected model for reduction**

model name

Specify the model you want to reduce by selecting from the **Model** drop-down list. The list includes all models currently in the data browser. To get a model from the MATLAB workspace into the data browser, on the **Model Reducer** tab, click  **Import Model**. You can import any:

- `tf`, `ss`, or `zpk` model that is proper. The model can be SISO or MIMO, and continuous or discrete.
 - Continuous-time models must not have time delays. To reduce a continuous-time model with time delays, first use `pade` to approximate the time delays as model dynamics.
 - Discrete-time models can have time delays. For the Balanced Truncation reduction method, the app uses `absorbDelay` to convert the delay into poles at $z = 0$ before reducing the model. The additional states are reflected in the response plot and Hankel singular-value plot.
- Generalized model such as a `genss` model. The **Model Reducer** app uses the current or nominal value of all control design blocks in `model` (see `getValue`).

For more information, see “Mode-Selection Model Reduction”.

Note Reduce Model Order assumes that the model time unit (specified in the `TimeUnit` property of the model) is seconds. If your model does not have `TimeUnit = 'seconds'`, use `chgTimeUnit` to convert the model to seconds.

Lower Cutoff — Lowest mode frequency

positive scalar

Enter the frequency of the slowest dynamics to preserve in the reduced model. Poles with natural frequency below this cutoff are eliminated from the reduced model.

Upper Cutoff — Highest mode frequency

positive scalar

Enter the frequency of the fastest dynamics to preserve in the reduced model. Poles with natural frequency above this cutoff are eliminated from the reduced model.

Pole/Zero Simplification Tab

Model — Currently selected model for reduction

model name

Specify the model you want to reduce by selecting from the **Model** drop-down list. The list includes all models currently in the data browser. To get a model from the MATLAB workspace into the data

browser, on the **Model Reducer** tab, click  **Import Model**. You can import any:

- `tf`, `ss`, or `zpk` model that is proper. The model can be SISO or MIMO, and continuous or discrete.
 - Continuous-time models must not have time delays. To reduce a continuous-time model with time delays, first use `pade` to approximate the time delays as model dynamics.
 - Discrete-time models can have time delays. For the Balanced Truncation reduction method, the app uses `absorbDelay` to convert the delay into poles at $z = 0$ before reducing the model. The additional states are reflected in the response plot and Hankel singular-value plot.
- Generalized model such as a `genss` model. The **Model Reducer** app uses the current or nominal value of all control design blocks in `model` (see `getValue`).

Simplification of Pole-Zero Pairs — Tolerance for pole-zero cancellation

positive scalar

Set the tolerance for pole-zero cancellation by using the slider or entering a value in the text box. The value determines how close together a pole and zero must be for **Model Reducer** to eliminate them from the reduced model. Moving the slider to the left or entering a smaller value in the text box simplifies the model less, by cancelling fewer poles and zeros. Moving the slider to the right, or entering a larger value, simplifies the model more by cancelling poles and zeros that are further apart.

For more information, see “Pole-Zero Simplification”.

Programmatic Use

`modelReducer` opens the **Model Reducer** app with no models in the data browser. To import a model from the MATLAB workspace, click  **Import Model**.

`modelReducer(model)` opens app and imports the specified LTI model. `model` can be a:

- `tf`, `ss`, or `zpk` model that is proper. The model can be SISO or MIMO, and continuous or discrete.
 - Continuous-time models must not have time delays. To reduce a continuous-time model with time delays, first use `pade` to approximate the time delays as model dynamics.

- Discrete-time models can have time delays. For the Balanced Truncation reduction method, the app uses `absorbDelay` to convert the delay into poles at $z = 0$ before reducing the model. The additional states are reflected in the response plot and Hankel singular-value plot.
- Generalized model such as a `genss` model. The **Model Reducer** app uses the current or nominal value of all control design blocks in `model` (see `getValue`).

`modelReducer(model1, ..., modelN)` opens the app and imports the specified models.

`modelReducer(sessionFile)` opens the app and loads a previously saved session. `sessionFile` is the name of a session data file in the current working directory or on the MATLAB path.

To save session data to disk, in the **Model Reducer** app, on the **Model Reducer** tab, click  **Save Session**. The saved session data includes the current plot configuration and all models in the data browser.

Version History

Introduced in R2016a

See Also

Functions

`balred` | `minreal` | `freqsep`

Live Editor Tasks

Reduce Model Order

Topics

“Model Reduction Basics”

“Reduce Model Order Using the Model Reducer App”

“Balanced Truncation Model Reduction”

“Pole-Zero Simplification”

“Mode-Selection Model Reduction”

modsep

Region-based modal decomposition

Syntax

```
[H,H0] = modsep(G,N,REGIONFCN)
MODSEP(G,N,REGIONFCN,PARAM1,...)
```

Description

`[H,H0] = modsep(G,N,REGIONFCN)` decomposes the LTI model `G` into a sum of `n` simpler models `Hj` with their poles in disjoint regions `Rj` of the complex plane:

$$G(s) = H0 + \sum_{j=1}^N H_j(s)$$

`G` can be any LTI model created with `ss`, `tf`, or `zpk`, and `N` is the number of regions used in the decomposition. `modsep` packs the submodels `Hj` into an LTI array `H` and returns the static gain `H0` separately. Use `H(:, :, j)` to retrieve the submodel `Hj(s)`.

To specify the regions of interest, use a function of the form

```
IR = REGIONFCN(p)
```

that assigns a region index `IR` between 1 and `N` to a given pole `p`. You can specify this function by its name or as a function handle, and use the syntax `MODSEP(G,N,REGIONFCN,PARAM1,...)` to pass extra input arguments:

```
IR = REGIONFCN(p,PARAM1,...)
```

Examples

To decompose `G` into $G(z) = H0 + H1(z) + H2(z)$ where `H1` and `H2` have their poles inside and outside the unit disk respectively, use

```
[H,H0] = modsep(G,2,@udsep)
```

where the function `udsep` is defined by

```
function r = udsep(p)
if abs(p)<1, r = 1; % assign r=1 to poles inside unit disk
else      r = 2; % assign r=2 to poles outside unit disk
end
```

To extract `H1(z)` and `H2(z)` from the LTI array `H`, use

```
H1 = H(:, :, 1); H2 = H(:, :, 2);
```

Version History

Introduced before R2006a

See Also
stabsep

nblocks

Number of blocks in Generalized matrix or Generalized LTI model

Syntax

`N = nblocks(M)`

Description

`N = nblocks(M)` returns the number of “Control Design Blocks” in the Generalized LTI model or Generalized matrix `M`.

Input Arguments

M

A Generalized LTI model (genss or genfrd model), a Generalized matrix (genmat), or an array of such models.

Output Arguments

N

The number of “Control Design Blocks” in `M`. If a block appears multiple times in `M`, `N` reflects the total number of occurrences.

If `M` is a model array, `N` is an array with the same dimensions as `M`. Each entry of `N` is the number of Control Design Blocks in the corresponding entry of `M`.

Examples

Number of Control Design Blocks in a Second-Order Filter Model

This example shows how to use `nblocks` to examine two different ways of parameterizing a model of a second-order filter.

- 1 Create a tunable (parametric) model of the second-order filter:

$$F(s) = \frac{\omega_n^2}{s^2 + 2\zeta\omega_n s + \omega_n^2},$$

where the damping ζ and the natural frequency ω_n are tunable parameters.

```
wn = realp('wn',3);
zeta = realp('zeta',0.8);
F = tf(wn^2,[1 2*zeta*wn wn^2]);
```

`F` is a genss model with two tunable Control Design Blocks, the `realp` blocks `wn` and `zeta`. The blocks `wn` and `zeta` have initial values of 3 and 0.8, respectively.

- 2 Examine the number of tunable blocks in the model using `nblocks`.

```
nblocks(F)
```

This command returns the result:

```
ans =
```

```
6
```

F has two tunable parameters, but the parameter `wn` appears five times — twice in the numerator and three times in the denominator.

- 3 Rewrite F for fewer occurrences of `wn`.

The second-order filter transfer function can be expressed as follows:

$$F(s) = \frac{1}{\left(\frac{s}{\omega_n}\right)^2 + 2\zeta\left(\frac{s}{\omega_n}\right) + 1}.$$

Use this expression to create the tunable filter:

```
F = tf(1, [(1/wn)^2 2*zeta*(1/wn) 1])
```

- 4 Examine the number of tunable blocks in the new filter model.

```
nblocks(F)
```

This command returns the result:

```
ans =
```

```
4
```

In the new formulation, there are only three occurrences of the tunable parameter `wn`. Reducing the number of occurrences of a block in a model can improve performance time of calculations involving the model. However, the number of occurrences does not affect the results of tuning the model or sampling the model for parameter studies.

Version History

Introduced in R2011a

See Also

`genss` | `genfrd` | `genmat` | `getValue`

Topics

“Control Design Blocks”

“Generalized Matrices”

“Generalized and Uncertain LTI Models”

ndBasis

Basis functions for tunable gain surface

Syntax

```
shapefcn = ndBasis(F1,F2)
shapefcn = ndBasis(F1,F2,...,FN)
```

Description

You use basis function expansions to parameterize gain surfaces for tuning gain-scheduled controllers, with the `tunableSurface` command. The complexity of such expansions grows quickly when you have multiple scheduling variables. Use `ndBasis` to build N-dimensional expansions from low-dimensional expansions. `ndBasis` is analogous to `ndgrid` in the way it spatially replicates the expansions along each dimension.

`shapefcn = ndBasis(F1,F2)` forms the outer (tensor) product of two basis function expansions. Each basis function expansion is a function that returns a vector of expansion terms, such as returned by `polyBasis`. If $F_1(x_1) = [F_{1,1}(x_1), F_{1,2}(x_1), \dots, F_{1,i}(x_1)]$ and $F_2(x_2) = [F_{2,1}(x_2), F_{2,2}(x_2), \dots, F_{2,i}(x_2)]$, then `shapefcn` is a vector of terms of the form:

$$F_{ij} = F_{1,i}(x_1)F_{2,j}(x_2).$$

The terms are listed in a column-oriented fashion, with i varying first, then j .

`shapefcn = ndBasis(F1,F2,...,FN)` forms the outer product of three or more basis function expansions. The terms in the vector returned by `shapefcn` are of the form:

$$F_{i_1 \dots i_N} = F_{1,i_1}(x_1)F_{2,i_2}(x_2) \dots F_{N,i_N}(x_N).$$

These terms are listed in sort order that of an N-dimensional array, with i_1 varying first, then i_2 , and so on. Each F_j can itself be a multi-dimensional basis function expansion.

Examples

Polynomial Basis Functions of Two Variables

Create a two-dimensional basis of polynomial functions to second-order in both variables.

Define a one-dimensional set of basis functions.

```
F = @(x)[x,x^2];
```

Equivalently, you can use `polyBasis` to create F.

```
F = polyBasis('canonical',2);
```

Generate a two-dimensional expansion from F.

```
F2D = ndBasis(F,F);
```

F2D is a function of two variables. The function returns a vector containing the evaluated basis functions of those two variables:

$$F2D(x, y) = [x, x^2, y, yx, yx^2, y^2, xy^2, x^2y^2].$$

To confirm this, evaluate F2D for $x = 0.2$, $y = -0.3$.

```
F2D(0.2, -0.3)
```

```
ans = 1x8
```

```
0.2000    0.0400   -0.3000   -0.0600   -0.0120    0.0900    0.0180    0.0036
```

The expansion you combine with `ndBasis` need not have the same order. For instance, combine `F` with first-order expansion in one variable.

```
G = @(y)[y];
F2D2 = ndBasis(F,G);
```

The array returned by `F2D2` is similar to that returned by `F2D`, without the terms that are quadratic in the second variable.

$$F2D2(x, y) = [x, x^2, y, yx, yx^2].$$

Evaluate `F2D2` for $x = 0.2$, $y = -0.3$ to confirm the order of terms.

```
F2D2(0.2, -0.3)
```

```
ans = 1x5
```

```
0.2000    0.0400   -0.3000   -0.0600   -0.0120
```

Mixed Multi-Dimensional Basis Functions

Create a set of two-dimensional basis functions where the expansion is quadratic in one variable and periodic in the other variable.

First generate the one-dimensional expansions. Name the variables for improved readability.

```
F1 = polyBasis('canonical',2,'x');
F2 = fourierBasis(1,1,'y');
```

For simplicity, this example takes only the first harmonic of the periodic variation. These expansions have basis functions given by:

$$F1(x) = [x, x^2], \quad F2(y) = [\cos(\pi y), \sin(\pi y)].$$

Create the two-dimensional basis function expansion. Note that `ndBasis` preserves the variable names you assigned to one-dimensional expansions.

```
F = ndBasis(F1,F2)
```

```
F = function_handle with value:
@(x,y)utFcnBasisOuterProduct(FDATA_,x,y)
```

The array returned by F includes all multiplicative combinations of the basis functions:

$$F(x, y) = [x, x^2, \cos(\pi y), \cos(\pi y)x, \cos(\pi y)x^2, \sin(\pi y), x\sin(\pi y), x^2\sin(\pi y)].$$

To confirm this, evaluate F for $x = 0.2$, $y = -0.3$.

```
F(0.2, -0.3)
```

```
ans = 1x8
```

```
    0.2000    0.0400    0.5878    0.1176    0.0235   -0.8090   -0.1618   -0.0324
```

Input Arguments

F — Basis function expansion

function handle

Basis function expansion, specified as a function handle. The function must return a vector of basis functions of one or more scheduling variables. You can define these basis functions explicitly, or using `polyBasis` or `fourierBasis`.

Example: `F = @(x) [x, x^2, x^3]`

Example: `F = polyBasis(3,2)`

Output Arguments

shapefcn — Basis function expansion

function handle

Basis function expansion, specified as a function handle. `shapefcn` takes as input arguments the total number of variables in F_1, F_2, \dots, F_N . It returns a vector of functions of those variables, defined on the interval $[-1,1]$ for each input variable. When you use `shapefcn` to create a gain surface, `tunableSurface` automatically generates tunable coefficients for each term in the vector.

Tips

- The `ndBasis` operation is associative:

```
ndBasis(F1, ndBasis(F2, F3)) = ndBasis(ndBasis(F1, F2), F3) = ndBasis(F1, F2, F3)
```

Version History

Introduced in R2015b

See Also

`tunableSurface` | `fourierBasis` | `polyBasis`

ndims

Query number of dimensions of dynamic system model or model array

Syntax

```
n = ndims(sys)
```

Description

`n = ndims(sys)` is the number of dimensions of a dynamic system model or a model array `sys`. A single model has two dimensions (one for outputs, and one for inputs). A model array has $2 + p$ dimensions, where $p \geq 2$ is the number of array dimensions. For example, a 2-by-3-by-4 array of models has $2 + 3 = 5$ dimensions.

```
ndims(sys) = length(size(sys))
```

Examples

Determine Dimensions of Model Array

Create a 3-by-1 array of random state-space models, each with 4 states, 1 input, and 1 output.

```
sys = rss(4,1,1,3);
```

Compute the number of dimensions of the model array.

```
ndims(sys)
```

```
ans = 4
```

The number of dimensions is $2+p$, where p is the number of array dimensions. In this example, p is 2 because `sys` is 3-by-1.

Version History

Introduced before R2006a

See Also

`size`

ngrid

Superimpose Nichols chart on Nichols plot

Syntax

```
ngrid
ngrid('new')
ngrid(AX, ___)
```

Description

`ngrid` superimposes Nichols chart grid lines over the Nichols frequency response of a SISO LTI system. The range of the Nichols grid lines is set to encompass the entire Nichols frequency response.

The chart relates the complex number $H/(1 + H)$ to H , where H is any complex number. For SISO systems, when H is a point on the open-loop frequency response, then the corresponding value of the closed-loop frequency response assuming unit negative feedback is

$$\frac{H}{1 + H}$$

If the current axis is empty, `ngrid` generates a new Nichols chart grid in the region -40 dB to 40 dB in magnitude and -360 degrees to 0 degrees in phase. `ngrid` returns a warning if the current axis does not contain a SISO Nichols frequency response.

`ngrid('new')` clears the current axes first and sets `hold` on.

`ngrid(AX, ___)` plots the grid on the `Axes` or `UIAxes` object in the current figure with the handle `AX`. Use this syntax when creating apps with `ngrid` in the App Designer.

Examples

Nichols Response with Nichols Grid Lines

Plot the Nichols response with Nichols grid lines for the following system:

$$H(s) = \frac{-4s^4 + 48s^3 - 18s^2 + 250s + 600}{s^4 + 30s^3 + 282s^2 + 525s + 60}$$

```
H = tf([-4 48 -18 250 600],[1 30 282 525 60]);
nichols(H)
ngrid
```

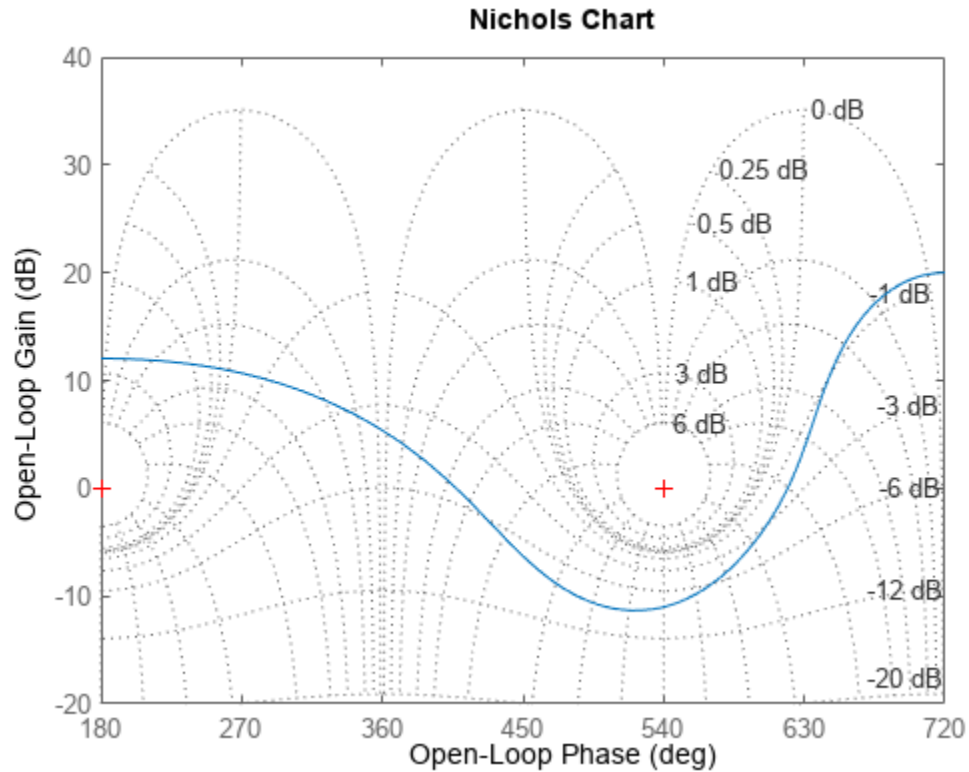

Input Arguments

AX — Object handle

Axes object | UIAxes object

Object handle, specified as an Axes or UIAxes object. Use AX to create apps with ngrid in the App Designer.

Version History

Introduced before R2006a

See Also

nichols

nichols

Nichols chart of frequency response

Syntax

```
nichols(sys)
nichols(sys1,sys2,...,sysN)
nichols(sys1,LineStyle1,...,sysN,LineStyleN)
nichols( __ ,w)
```

```
[mag,phase,wout] = nichols(sys)
[mag,phase,wout] = nichols(sys,w)
```

Description

`nichols(sys)` creates a Nichols chart of the frequency response of a dynamic system model `sys`. The plot displays the magnitude (in dB) and phase (in degrees) of the system response as a function of frequency. `nichols` automatically determines frequencies to plot based on system dynamics. Use `ngrid` to superimpose Nichols chart grid lines on an existing SISO Nichols chart.

If `sys` is a multi-input, multi-output (MIMO) model, then `nichols` produces an array of Nichols charts, each plot showing the frequency response of one I/O pair.

If `sys` is a model with complex coefficients, then `nichols` plot shows a contour comprised of both positive and negative frequencies. For models with real coefficients, `nichols` only shows positive frequencies.

`nichols(sys1,sys2,...,sysN)` plots the Nichols plot of the frequency response of multiple dynamic systems on the same plot. All systems must have the same number of inputs and outputs.

`nichols(sys1,LineStyle1,...,sysN,LineStyleN)` specifies a color, line style, and marker for each system in the plot.

`nichols(__ ,w)` plots the response for frequencies specified by `w`.

- If `w` is a cell array of the form `{wmin,wmax}`, then `nichols` plots the chart at frequencies ranging between `wmin` and `wmax`.
- If `w` is a vector of frequencies, then `nichols` plots the chart at each specified frequency. The vector `w` can contain both negative and positive frequencies.

You can use `w` with any of the input-argument combinations in previous syntaxes.

`[mag,phase,wout] = nichols(sys)` returns the magnitude and phase of the response at each frequency in the vector `wout`. The function automatically determines frequencies in `wout` based on system dynamics. This syntax does not draw a plot.

`[mag,phase,wout] = nichols(sys,w)` returns the response data at the frequencies specified by `w`.

- If `w` is a cell array of the form `{wmin,wmax}`, then `wout` contains frequencies ranging between `wmin` and `wmax`.

- If w is a vector of frequencies, then $wout = w$.

Examples

Nichols Response with Nichols Grid Lines

Plot the Nichols response with Nichols grid lines for the following system:

$$H(s) = \frac{-4s^4 + 48s^3 - 18s^2 + 250s + 600}{s^4 + 30s^3 + 282s^2 + 525s + 60}$$

```
H = tf([-4 48 -18 250 600],[1 30 282 525 60]);
nichols(H)
ngrid
```

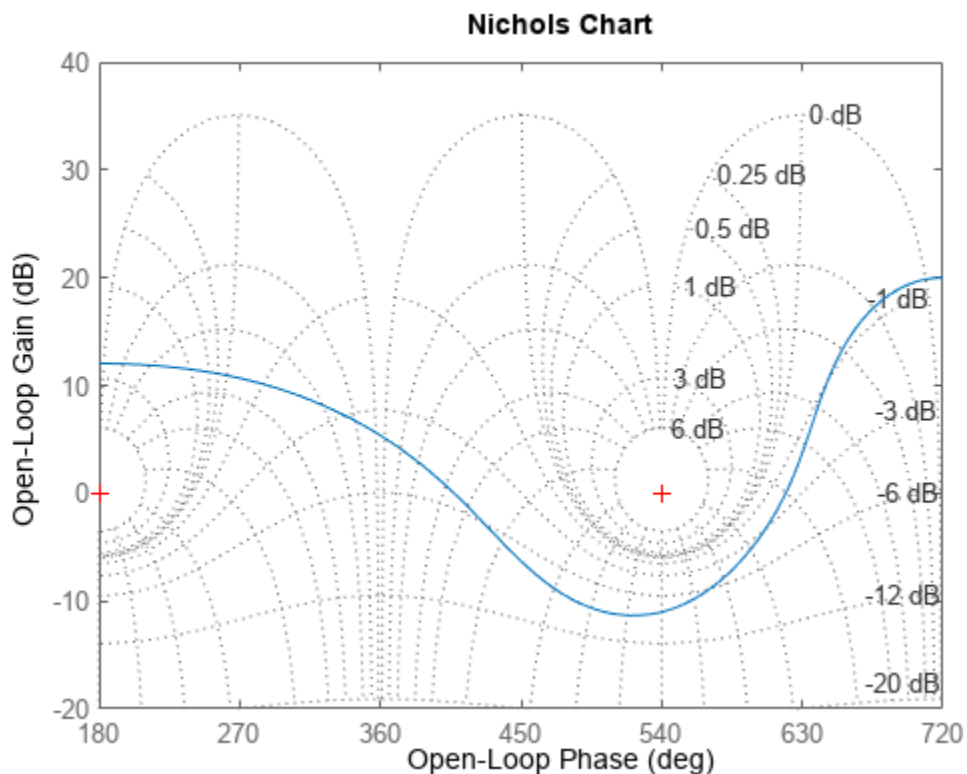

Nichols Plot at Specified Frequencies

Create a Nichols plot over a specified frequency range. Use this approach when you want to focus on the dynamics in a particular range of frequencies.

```
H = tf([-0.1, -2.4, -181, -1950], [1, 3.3, 990, 2600]);
nichols(H, {1, 100})
```

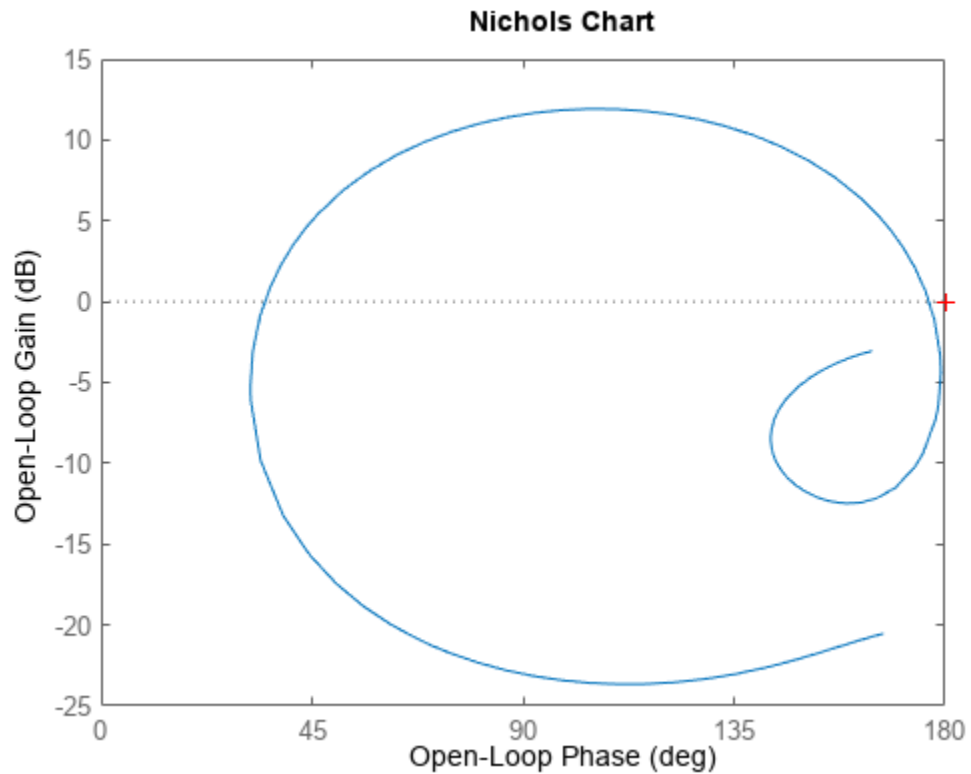

The cell array `{1, 100}` specifies the minimum and maximum frequency values in the Nichols plot. When you provide frequency bounds in this way, the function selects intermediate points for frequency response data.

Alternatively, specify a vector of frequency points to use for evaluating and plotting the frequency response.

```
w = 1:0.5:100;  
nichols(H,w, '.-')
```

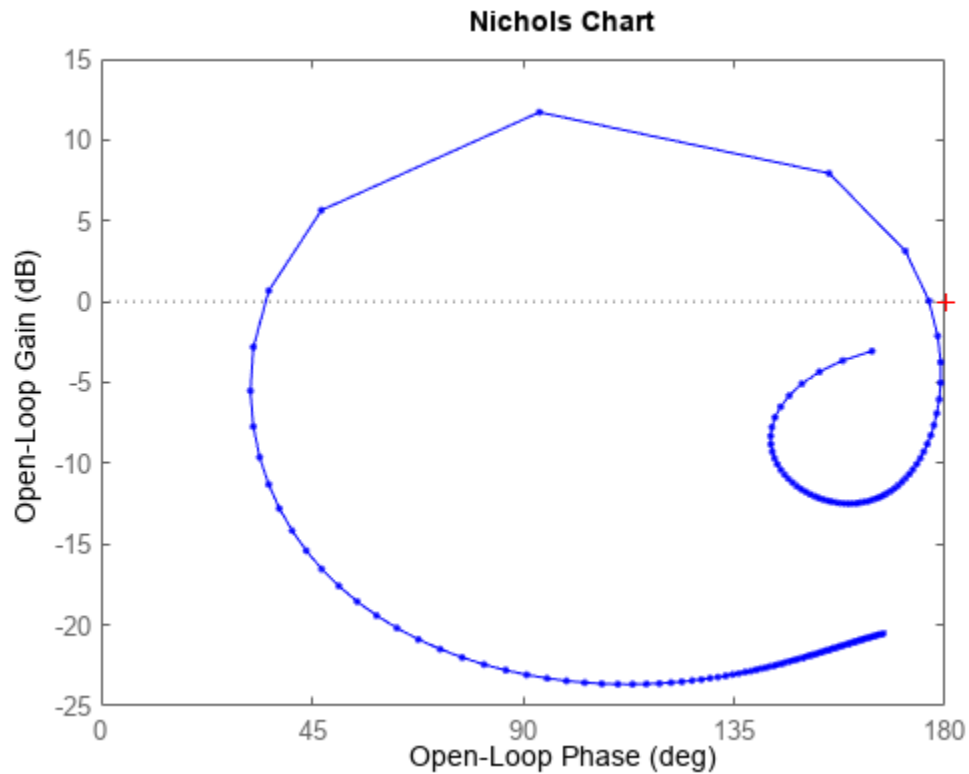
`nichols` plots the frequency response at the specified frequencies only.

Nichols Plot of Several Dynamic Systems

Compare the frequency response of a continuous-time system to an equivalent discretized system on the same Nichols plot.

Create continuous-time and discrete-time dynamic systems.

```
H = tf([1 0.1 7.5],[1 0.12 9 0 0]);
Hd = c2d(H,0.5,'zoh');
```

Create a Nichols plot that displays both systems.

```
nichols(H,Hd)
```

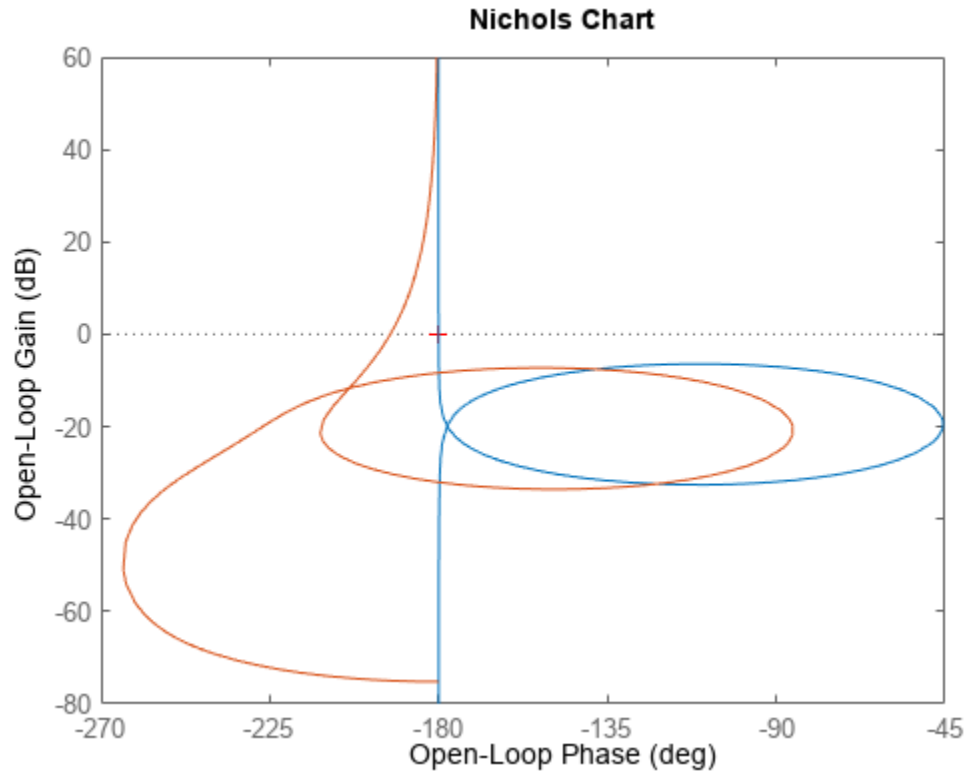

Nichols Plot with Specified Line Attributes

Specify the line style, color, or marker for each system in a Nichols plot using the `LineStyle` input argument.

```
H = tf([1 0.1 7.5],[1 0.12 9 0 0]);  
Hd = c2d(H,0.5,'zoh');  
nichols(H,'r',Hd,'b--')
```

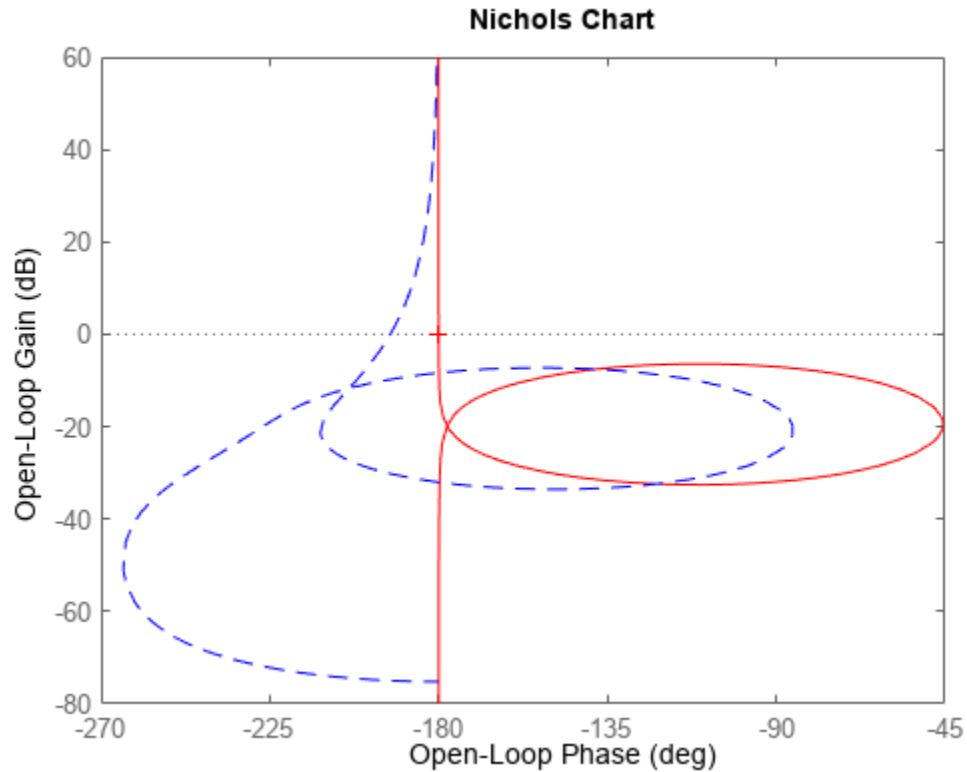

The first LineSpec, 'r', specifies a solid red line for the response of H. The second LineSpec, 'b--', specifies a dashed blue line for the response of Hd.

Nichols Response Magnitude and Phase Data

Compute the magnitude and phase of the frequency response of a SISO system.

If you do not specify frequencies, `nichols` chooses frequencies based on the system dynamics and returns them in the third output argument.

```
H = tf([1 0.1 7.5],[1 0.12 9 0 0]);
[mag,phase,wout] = nichols(H);
```

Because H is a SISO model, the first two dimensions of `mag` and `phase` are both 1. The third dimension is the number of frequencies in `wout`.

```
size(mag)
```

```
ans = 1×3
```

```
1 1 110
```

```
length(wout)
```

```
ans = 110
```

Thus, each entry along the third dimension of `mag` gives the magnitude of the response at the corresponding frequency in `wout`.

Nichols Plot of MIMO System

For this example, create a 2-output, 3-input system.

```
rng(0, 'twister');
H = rss(4,2,3);
```

For this system, `nichols` plots the frequency responses of each I/O channel in a separate plot in a single figure.

```
nichols(H)
```

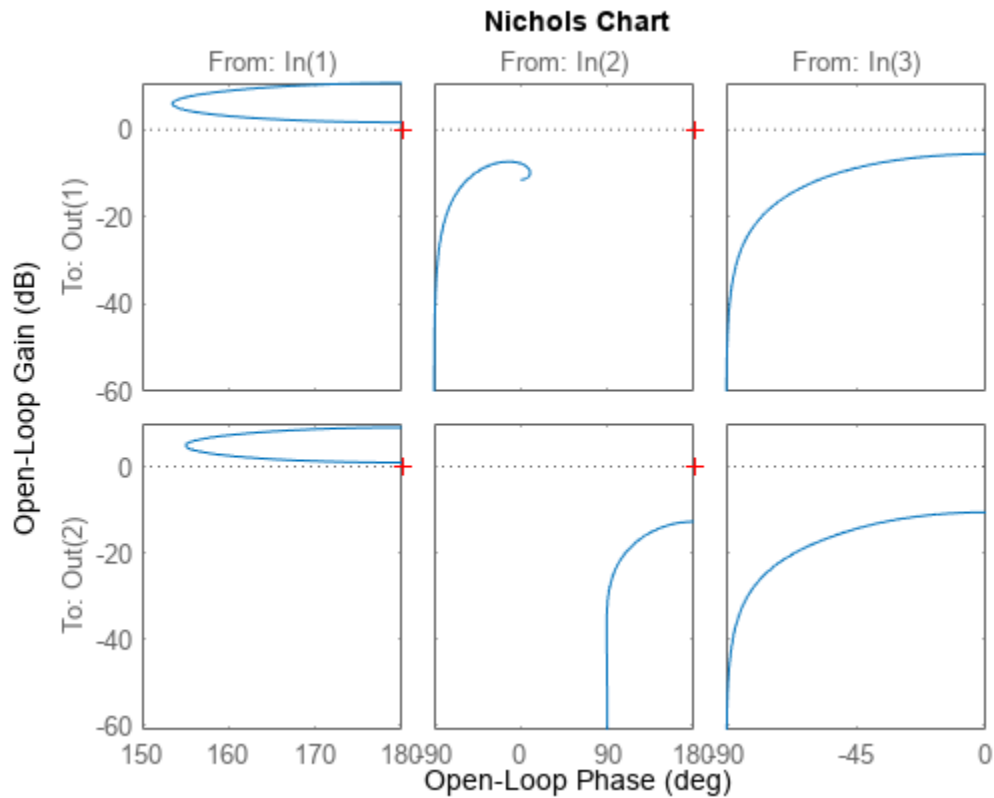

Compute the magnitude and phase of these responses at 20 frequencies between 1 and 10 radians.

```
w = logspace(0,1,20);
[mag,phase] = nichols(H,w);
```

`mag` and `phase` are three-dimensional arrays, in which the first two dimensions correspond to the output and input dimensions of `H`, and the third dimension is the number of frequencies. For instance, examine the dimensions of `mag`.

```

size(mag)
ans = 1×3
     2     3    20

```

Thus, for example, `mag(1,3,10)` is the magnitude of the response from the third input to the first output, computed at the 10th frequency in `w`. Similarly, `phase(1,3,10)` contains the phase of the same response.

Nichols Plot of Model with Complex Coefficients

Create a Nichols plot of a model with complex coefficients and a model with real coefficients on the same plot.

```

rng(0)
A = [-3.50, -1.25-0.25i; 2, 0];
B = [1; 0];
C = [-0.75-0.5i, 0.625-0.125i];
D = 0.5;
Gc = ss(A,B,C,D);
Gr = rss(7);
nichols(Gc,Gr)
legend('Complex-coefficient model', 'Real-coefficient model', 'Location', 'southwest')

```

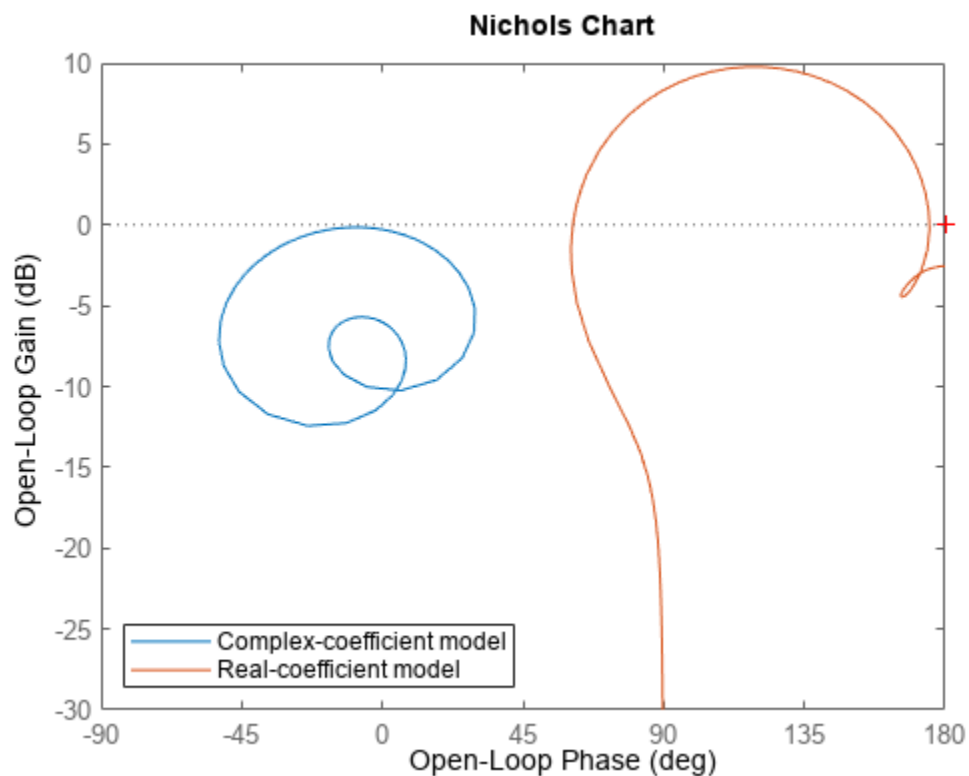

For models with complex coefficients, `nichols` shows a contour comprised of both positive and negative frequencies. For models with real coefficients, the plot shows only positive frequencies, even when complex-coefficient models are present. You can click the curve to further examine which section and values correspond to positive and negative frequencies.

Input Arguments

sys — Dynamic system

dynamic system model | model array

Dynamic system, specified as a SISO or MIMO dynamic system model or array of dynamic system models. Dynamic systems that you can use include:

- Continuous-time or discrete-time numeric LTI models, such as `tf`, `zpk`, or `ss` models.
- Generalized or uncertain LTI models such as `genss` or `uss` models. (Using uncertain models requires Robust Control Toolbox software.)
 - For tunable control design blocks, the function evaluates the model at its current value for both plotting and returning frequency response data.
 - For uncertain control design blocks, the function plots the nominal value and random samples of the model. When you use output arguments, the function returns frequency response data for the nominal model only.
- Frequency-response data models such as `frd` models. For such models, the function plots the response at frequencies defined in the model.
- Identified LTI models, such as `idtf`, `idss`, or `idproc` models. Using identified models requires System Identification Toolbox software.

If `sys` is an array of models, the function plots the frequency responses of all models in the array on the same axes.

LineStyle — Line style, marker, and color

character vector | string

Line style, marker, and color, specified as a string or vector of one, two, or three characters. The characters can appear in any order. You do not need to specify all three characteristics (line style, marker, and color). For example, if you omit the line style and specify the marker, then the plot shows only the marker and no line. For more information about configuring this argument, see the `LineStyle` input argument of the `plot` function.

Example: `'r--'` specifies a red dashed line

Example: `'*b'` specifies blue asterisk markers

Example: `'y'` specifies a yellow line

w — Frequencies

{wmin,wmax} | vector

Frequencies at which to compute and plot frequency response, specified as the cell array `{wmin,wmax}` or as a vector of frequency values.

- If `w` is a cell array of the form `{wmin,wmax}`, then the function computes the response at frequencies ranging between `wmin` and `wmax`.

- If w is a vector of frequencies, then the function computes the response at each specified frequency. For example, use `logspace` to generate a row vector with logarithmically spaced frequency values. The vector w can contain both positive and negative frequencies.

For models with complex coefficients, if you specify a frequency range of $[w_{\min}, w_{\max}]$ for your plot, then the plot shows a contour comprised of both positive frequencies $[w_{\min}, w_{\max}]$ and negative frequencies $[-w_{\max}, -w_{\min}]$.

Specify frequencies in units of $\text{rad}/\text{TimeUnit}$, where `TimeUnit` is the `TimeUnit` property of the model.

Output Arguments

mag — Magnitude of system response

3-D array

Magnitude of the system response in absolute units, returned as a 3-D array. The dimensions of this array are (number of system outputs) \times (number of system inputs) \times (number of frequency points).

- For SISO systems, `mag(1, 1, k)` gives the magnitude of the response at the k th frequency in w or `wout`. For an example, see “Nichols Response Magnitude and Phase Data” on page 2-777.
- For MIMO systems, `mag(i, j, k)` gives the magnitude of the response at the k th frequency from the j th input to the i th output. For an example, see “Nichols Plot of MIMO System” on page 2-778.

To convert the magnitude from absolute units to decibels, use:

$$\text{magdb} = 20 * \log_{10}(\text{mag})$$

phase — Phase of system response

3-D array

Phase of the system response in degrees, returned as a 3-D array. The dimensions of this array are (number of outputs)-by-(number of inputs)-by-(number of frequency points).

- For SISO systems, `phase(1, 1, k)` gives the phase of the response at the k th frequency in w or `wout`. For an example, see “Nichols Response Magnitude and Phase Data” on page 2-777.
- For MIMO systems, `phase(i, j, k)` gives the phase of the response at the k th frequency from the j th input to the i th output. For an example, see “Nichols Plot of MIMO System” on page 2-778.

wout — Frequencies

vector

Frequencies at which the function returns the system response, returned as a column vector. The function chooses the frequency values based on the model dynamics, unless you specify frequencies using the input argument w .

`wout` also contains negative frequency values for models with complex coefficients.

Frequency values are in $\text{radians}/\text{TimeUnit}$, where `TimeUnit` is the value of the `TimeUnit` property of `sys`.

Tips

- When you need additional plot customization options, use `nicholsplot` instead.

Version History

Introduced before R2006a

See Also

`nyquist` | `bode` | `nicholsplot` | `ngrid`

Topics

“Frequency-Domain Responses”

“Dynamic System Models”

nicholsoptions

Create list of Nichols plot options

Description

Use the `nicholsoptions` command to create a `NicholsOptions` object to customize your Nichols plot appearance. You can also use the command to override the plot preference settings in the MATLAB session in which you create the Nichols plots.

Creation

Syntax

```
plotoptions = nicholsoptions  
plotoptions = nicholsoptions('cstprefs')
```

Description

`plotoptions = nicholsoptions` returns a default set of plot options for use with the `nicholsplot` command. You can use these options to customize the Nichols plot appearance using the command line. This syntax is useful when you want to write a script to generate plots that look the same regardless of the preference settings of the MATLAB session in which you run the script.

`plotoptions = nicholsoptions('cstprefs')` initializes the plot options with the options you selected in the Control System Toolbox Preferences Editor. For more information about the editor, see “Toolbox Preferences Editor”. This syntax is useful when you want to change a few plot options but otherwise use your default preferences. A script that uses this syntax may generate results that look different when run in a session with different preferences.

Properties

FreqUnits — Frequency units

'rad/s' (default)

Frequency units, specified as one of the following values:

- 'Hz'
- 'rad/s'
- 'rpm'
- 'kHz'
- 'MHz'
- 'GHz'
- 'rad/nanosecond'
- 'rad/microsecond'

- 'rad/millisecond'
- 'rad/minute'
- 'rad/hour'
- 'rad/day'
- 'rad/week'
- 'rad/month'
- 'rad/year'
- 'cycles/nanosecond'
- 'cycles/microsecond'
- 'cycles/millisecond'
- 'cycles/hour'
- 'cycles/day'
- 'cycles/week'
- 'cycles/month'
- 'cycles/year'

MagLowerLimMode — Lower magnitude limit mode

'auto' (default) | 'manual'

Lower magnitude limit mode, specified as either 'auto' or 'manual'.

MagLowerLim — Lower magnitude limit value

'-inf' (default) | scalar

Lower magnitude limit value, specified as a scalar.

PhaseUnits — Phase units

'deg' (default) | 'rad'

Phase units, specified as either 'deg' or 'rad' to change to degrees or radians, respectively.

PhaseWrapping — Enable phase wrapping

'off' (default) | 'on'

Enable phase wrapping, specified as either 'on' or 'off'. When you set PhaseWrapping to 'on', the plot wraps accumulated phase at the value specified by the PhaseWrappingBranch property.

PhaseWrappingBranch — Phase wrapping value

-180 (default) | integer

Phase wrapping value at which the plot wraps accumulated phase when PhaseWrapping is set to 'on'. By default, phase wraps into the interval $[-180^\circ, 180^\circ]$.

PhaseMatching — Enable phase matching

'off' (default) | 'on'

Enable phase matching, specified as either 'on' or 'off'. Turning PhaseMatching 'on' matches the phase to the value specified in PhaseMatchingValue at the frequency specified in PhaseMatchingFreq

PhaseMatchingFreq — Phase matching frequency

0 (default) | scalar

Phase matching frequency, specified as a scalar.

PhaseMatchingValue — Phase matching response value

0 (default) | scalar

Phase matching response value, specified as a scalar.

IOMGrouping — Grouping of input-output pairs

'none' (default) | 'inputs' | 'outputs' | 'all'

Grouping of input-output (I/O) pairs, specified as one of the following:

- 'none' — No input-output grouping.
- 'inputs' — Group only the inputs.
- 'outputs' — Group only the outputs.
- 'all' — Group all the I/O pairs.

InputLabels — Input label style

structure (default)

Input label style, specified as a structure with the following fields:

- **FontSize** — Font size, specified as a scalar value greater than zero in point units. The default font size depends on the specific operating system and locale. One point equals 1/72 inch.
- **FontWeight** — Character thickness, specified as 'Normal' or 'bold'. MATLAB uses the **FontWeight** property to select a font from those available on your system. Not all fonts have a bold weight. Therefore, specifying a bold font weight can still result in the normal font weight.
- **FontAngle** — Character slant, specified as 'Normal' or 'italic'. Not all fonts have both font styles. Therefore, the italic font might look the same as the normal font.
- **Color** — Text color, specified as an RGB triplet. The default color is dark grey with the RGB triplet [0.4,0.4,0.4].
- **Interpreter** — Text interpreter, specified as one of these values:
 - 'tex' — Interpret characters using a subset of TeX markup. This is the default value of **Interpreter**.
 - 'latex' — Interpret characters using LaTeX markup.
 - 'none' — Display literal characters.

OutputLabels — Output label style

structure (default)

Output label style, specified as a structure with the following fields:

- **FontSize** — Font size, specified as a scalar value greater than zero in point units. The default font size depends on the specific operating system and locale. One point equals 1/72 inch.
- **FontWeight** — Character thickness, specified as 'Normal' or 'bold'. MATLAB uses the **FontWeight** property to select a font from those available on your system. Not all fonts have a bold weight. Therefore, specifying a bold font weight can still result in the normal font weight.

- **FontAngle** — Character slant, specified as 'Normal' or 'italic'. Not all fonts have both font styles. Therefore, the italic font might look the same as the normal font.
- **Color** — Text color, specified as an RGB triplet. The default color is dark grey with the RGB triplet [0.4, 0.4, 0.4].
- **Interpreter** — Text interpreter, specified as one of these values:
 - 'tex' — Interpret characters using a subset of TeX markup. This is the default value of **Interpreter**.
 - 'latex' — Interpret characters using LaTeX markup.
 - 'none' — Display literal characters.

InputVisible — Toggle display of inputs

{'on'} (default) | {'off'} | cell array

Toggle display of inputs, specified as either {'on'}, {'off'} or a cell array with multiple elements .

OutputVisible — Toggle display of outputs

{'on'} (default) | {'off'} | cell array

Toggle display of outputs, specified as either {'on'}, {'off'} or a cell array with multiple elements.

Title — Title text and style

structure (default)

Title text and style, specified as a structure with the following fields:

- **String** — Label text, specified as a character vector. By default, the plot is titled 'Nichols Chart'.
- **FontSize** — Font size, specified as a scalar value greater than zero in point units. The default font size depends on the specific operating system and locale. One point equals 1/72 inch.
- **FontWeight** — Character thickness, specified as 'Normal' or 'bold'. MATLAB uses the **FontWeight** property to select a font from those available on your system. Not all fonts have a bold weight. Therefore, specifying a bold font weight can still result in the normal font weight.
- **FontAngle** — Character slant, specified as 'Normal' or 'italic'. Not all fonts have both font styles. Therefore, the italic font might look the same as the normal font.
- **Color** — Text color, specified as an RGB triplet. The default color is black specified by the RGB triplet [0, 0, 0].
- **Interpreter** — Text interpreter, specified as one of these values:
 - 'tex' — Interpret characters using a subset of TeX markup. This is the default value of **Interpreter**.
 - 'latex' — Interpret characters using LaTeX markup.
 - 'none' — Display literal characters.

XLabel — X-axis label text and style

structure (default)

X-axis label text and style, specified as a structure with the following fields:

- **String** — Label text, specified as a character vector. By default, the axis is titled based on the frequency units **FreqUnits**.

- **FontSize** — Font size, specified as a scalar value greater than zero in point units. The default font size depends on the specific operating system and locale. One point equals 1/72 inch.
- **FontWeight** — Character thickness, specified as 'Normal' or 'bold'. MATLAB uses the **FontWeight** property to select a font from those available on your system. Not all fonts have a bold weight. Therefore, specifying a bold font weight can still result in the normal font weight.
- **FontAngle** — Character slant, specified as 'Normal' or 'italic'. Not all fonts have both font styles. Therefore, the italic font might look the same as the normal font.
- **Color** — Text color, specified as an RGB triplet. The default color is black specified by the RGB triplet [0,0,0].
- **Interpreter** — Text interpreter, specified as one of these values:
 - 'tex' — Interpret characters using a subset of TeX markup. This is the default value of **Interpreter**.
 - 'latex' — Interpret characters using LaTeX markup.
 - 'none' — Display literal characters.

YLabel — Y-axis label text and style

structure (default)

Y-axis label text and style, specified as a structure with the following fields:

- **String** — Label text, specified as a cell array of character vectors. By default, the axis is titled 'Open-Loop Gain (dB)'.
- **FontSize** — Font size, specified as a scalar value greater than zero in point units. The default font size depends on the specific operating system and locale. One point equals 1/72 inch.
- **FontWeight** — Character thickness, specified as 'Normal' or 'bold'. MATLAB uses the **FontWeight** property to select a font from those available on your system. Not all fonts have a bold weight. Therefore, specifying a bold font weight can still result in the normal font weight.
- **FontAngle** — Character slant, specified as 'Normal' or 'italic'. Not all fonts have both font styles. Therefore, the italic font might look the same as the normal font.
- **Color** — Text color, specified as an RGB triplet. The default color is black specified by the RGB triplet [0,0,0].
- **Interpreter** — Text interpreter, specified as one of these values:
 - 'tex' — Interpret characters using a subset of TeX markup. This is the default value of **Interpreter**.
 - 'latex' — Interpret characters using LaTeX markup.
 - 'none' — Display literal characters.

TickLabel — Tick label style

structure (default)

Tick label style, specified as a structure with the following fields:

- **FontSize** — Font size, specified as a scalar value greater than zero in point units. The default font size depends on the specific operating system and locale. One point equals 1/72 inch.
- **FontWeight** — Character thickness, specified as 'Normal' or 'bold'. MATLAB uses the **FontWeight** property to select a font from those available on your system. Not all fonts have a bold weight. Therefore, specifying a bold font weight can still result in the normal font weight.

- **FontAngle** — Character slant, specified as 'Normal' or 'italic'. Not all fonts have both font styles. Therefore, the italic font might look the same as the normal font.
- **Color** — Text color, specified as an RGB triplet. The default color is black specified by the RGB triplet [0,0,0].

Grid — Toggle grid display`'off' (default) | 'on'`

Toggle grid display on the plot, specified as either 'off' or 'on'.

GridColor — Color of the grid lines`[0.15,0.15,0.15] (default) | RGB triplet`

Color of the grid lines, specified as an RGB triplet. The default color is light grey specified by the RGB triplet [0.15,0.15,0.15].

XLimMode — X-axis limit selection mode`'auto' (default) | 'manual' | cell array`

Selection mode for the x-axis limits, specified as one of these values:

- 'auto' — Enable automatic limit selection, which is based on the total span of the plotted data.
- 'manual' — Manually specify the axis limits. To specify the axis limits, set the XLim property.

YLimMode — Y-axis limit selection mode`'auto' (default) | 'manual' | cell array`

Selection mode for the y-axis limits, specified as one of these values:

- 'auto' — Enable automatic limit selection, which is based on the total span of the plotted data.
- 'manual' — Manually specify the axis limits. To specify the axis limits, set the YLim property.

XLim — X-axis limits`'{[1,10]}' (default) | cell array of two-element vector of the form [min,max] | cell array`

X-axis limits, specified as a cell array of two-element vector of the form [min,max].

YLim — Y-axis limits`'{[1,10]}' (default) | cell array of two-element vector of the form [min,max] | cell array`

Y-axis limits, specified as a cell array of two-element vector of the form [min,max].

Object Functions

`nicholsplot` Plot Nichols frequency responses with additional plot customization options

Examples**Customize Nichols Plot using Plot Handle**

For this example, use the plot handle to change the title, turn on the grid, and set axis limits.

Generate a random state-space model with 5 states and create the Nichols plot with plot handle `h`.

```
rng("default")
sys = rss(5);
h = nicholsplot(sys);
```

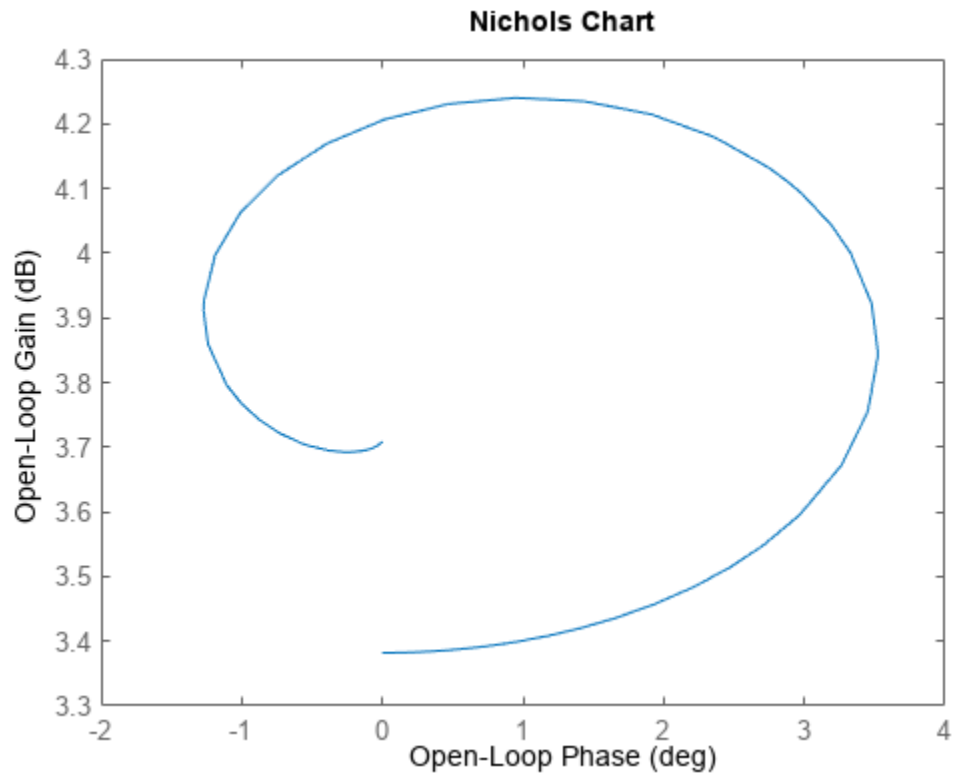

Change the title, enable the grid, and set axis limits. To do so, edit properties of the plot handle, `h` using `setoptions`.

```
Title.String = 'Nichols Frequency Response';
setoptions(h, 'Title', Title, 'Grid', 'on', 'XLim', [-2, 4], 'YLim', [3.3, 4.3]);
```

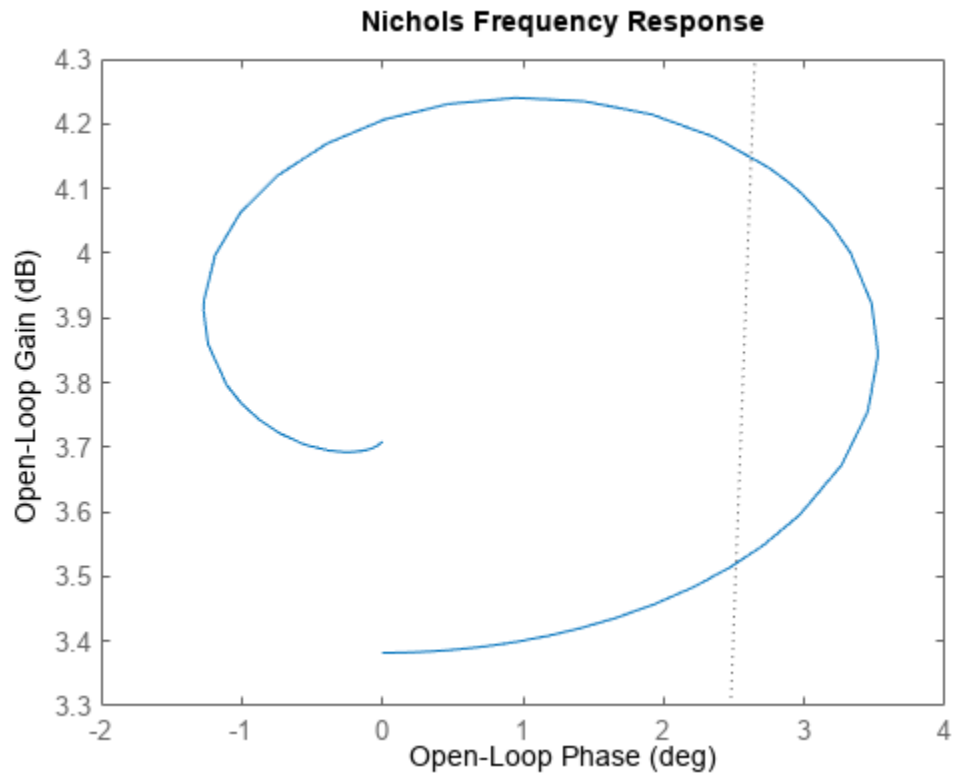

The Nichols plot automatically updates when you call `setoptions`.

Alternatively, you can also use the `nicholsoptions` command to specify the required plot options. First, create an options set based on the toolbox preferences.

```
plotoptions = nicholsoptions('cstprefs');
```

Change the desired properties of the options set.

```
plotoptions.Title.String = 'Nichols Frequency Response';  
plotoptions.Grid = 'on';  
plotoptions.XLim = [-2,4];  
plotoptions.YLim = [3.3,4.3];  
nicholsplot(sys,plotoptions);
```

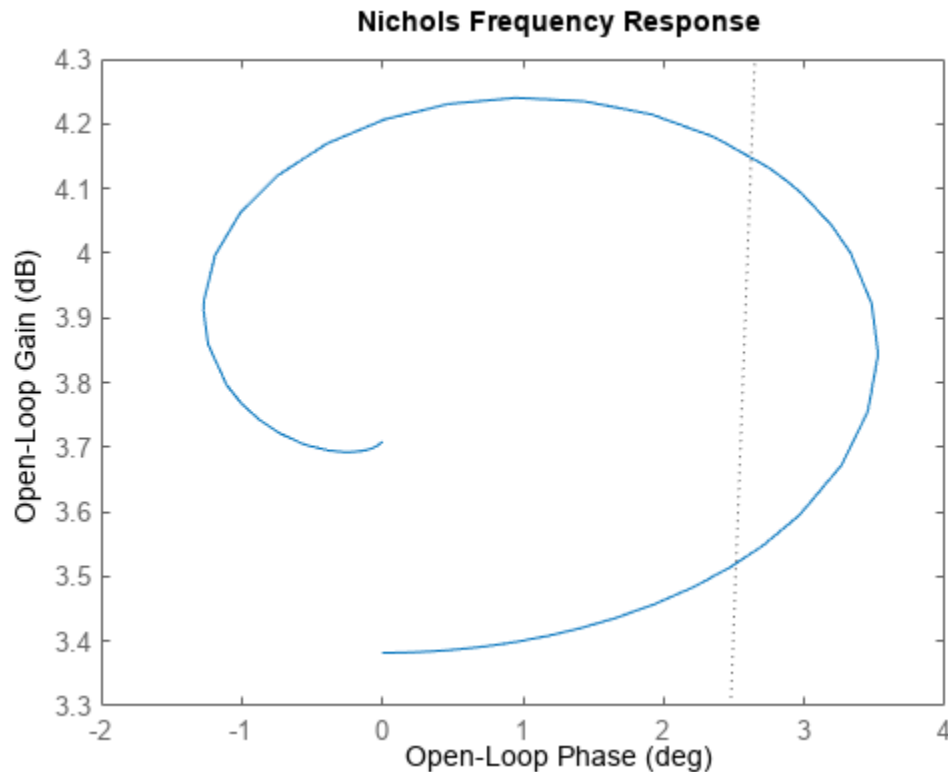
You can use the same option set to create multiple Nichols plots with the same customization. Depending on your own toolbox preferences, the plot you obtain might look different from this plot. Only the properties that you set explicitly, in this example `Title`, `Grid`, `XLim` and `YLim`, override the toolbox preferences.

Custom Nichols Plot Settings Independent of Preferences

For this example, create a Nichols plot that uses 15-point red text for the title. This plot should look the same, regardless of the preferences of the MATLAB session in which it is generated.

First, create a default options set using `nicholsoptions`.

```
plotoptions = nicholsoptions;
```

Next, change the required properties of the options set `plotoptions`.

```
plotoptions.Title.FontSize = 15;
plotoptions.Title.Color = [1 0 0];
plotoptions.FreqUnits = 'Hz';
plotoptions.Grid = 'on';
```

Now, create a Nichols plot using the options set `plotoptions`.

```
nicholsplot(tf(1,[1,1]),{0,15},plotoptions);
```

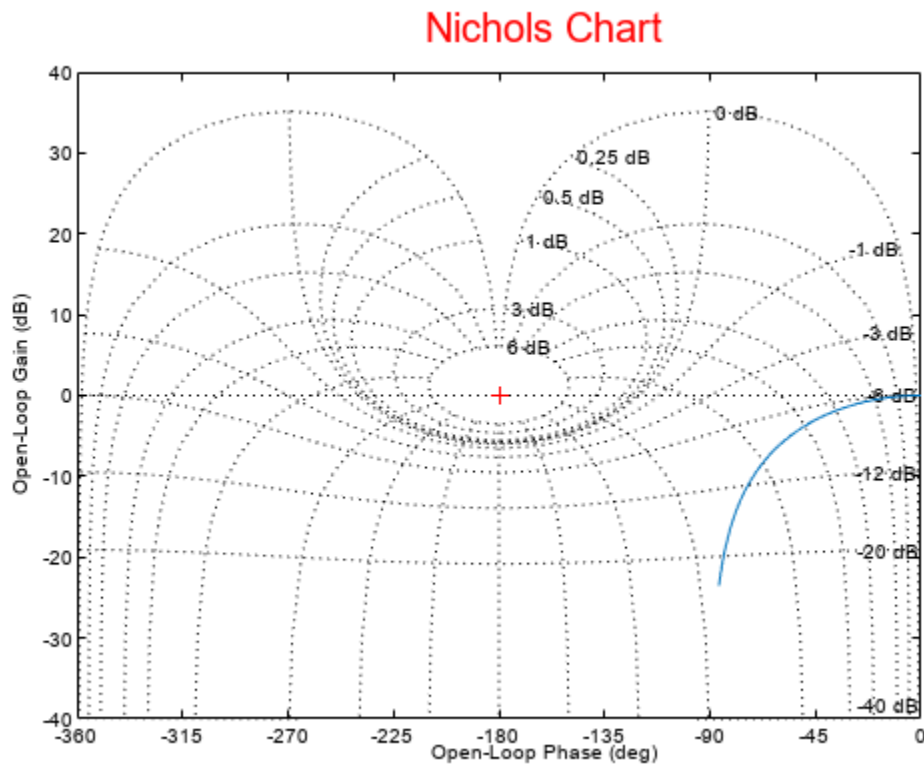

Because `plotoptions` begins with a fixed set of options, the plot result is independent of the toolbox preferences of the MATLAB session.

Customized Nichols Plot of Transfer Function

For this example, create a Nichols plot of the following continuous-time SISO dynamic system. Then, turn the grid on and rename the plot.

$$\text{sys}(s) = \frac{s^2 + 0.1s + 7.5}{s^4 + 0.12s^3 + 9s^2}$$

Create the transfer function `sys`.

```
sys = tf([1 0.1 7.5],[1 0.12 9 0 0]);
```

Next, create the options set using `nicholsoptions` and change the required plot properties.

```
plotoptions = nicholsoptions;
plotoptions.Grid = 'on';
plotoptions.Title.String = 'Nichols Plot of Transfer Function';
```

Now, create the Nichols plot with the custom option set `plotoptions`.

```
nicholsplot(sys,plotoptions)
```

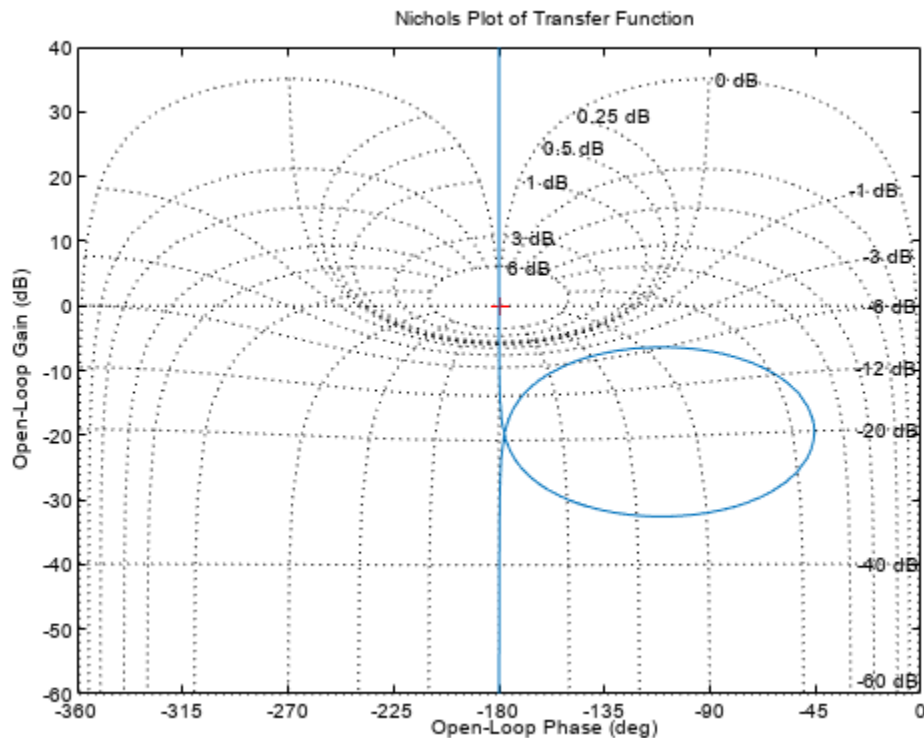

`nicholsplot` automatically selects the plot range based on the system dynamics.

Nichols Response of Identified Parametric and Nonparametric Models

For this example, compare the Nichols response of a parametric model, identified from input/output data, to a non-parametric model identified using the same data. Identify parametric and non-parametric models based on the data.

Load the data and create the parametric and non-parametric models using `tfest` and `spa`, respectively.

```
load iddata2 z2;
w = linspace(0,10*pi,128);
sys_np = spa(z2,[],w);
sys_p = tfest(z2,2);
```

`spa` and `tfest` require System Identification Toolbox™ software. The model `sys_np` is a non-parametric identified model while, `sys_p` is a parametric identified model.

Create an options set to turn phase matching and the grid on. Then, create a Nichols plot that includes both systems using this options set.

```
plotoptions = nicholsoptions;
plotoptions.PhaseMatching = 'on';
```

```

plotoptions.Grid = 'on';
plotoptions.XLim = {[ -240,0]};
h = nicholsplot(sys_p,'r.-.',sys_np,'b.-.',w,plotoptions);
legend('Parametric Model','Non-Parametric model');

```

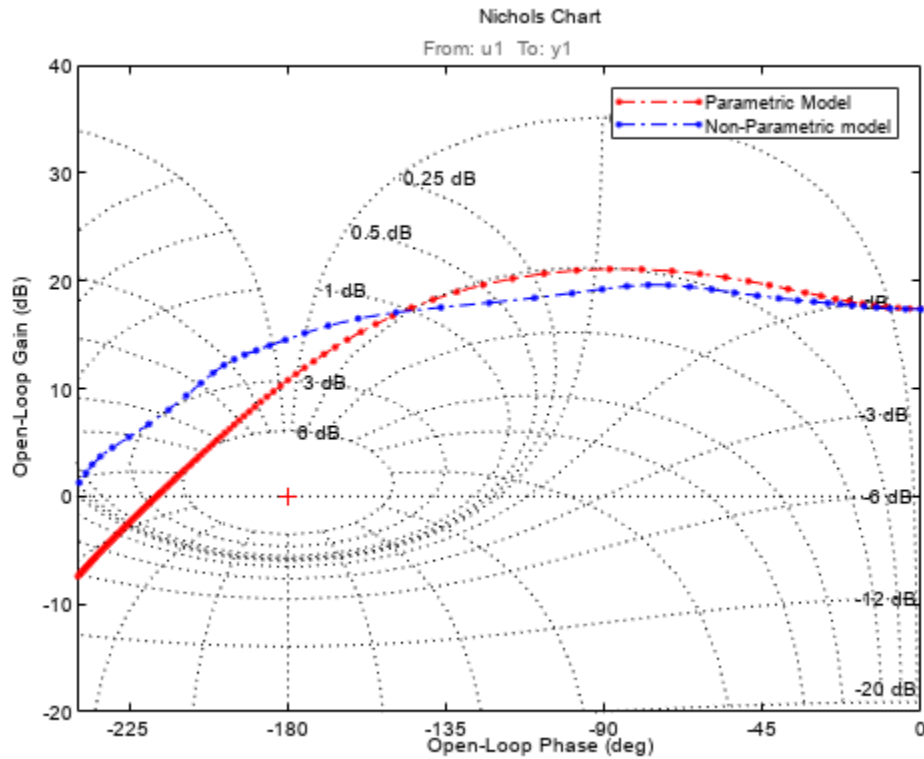

Set Options for Nichols Plot

Create an options set, and set the phase units and grid option.

```

P = nicholsoptions;
P.PhaseUnits = 'rad';
P.Grid = 'on';

```

Use the options set to generate a Nichols plot. Note the phase units and grid in the plot.

```

h = nicholsplot(tf(1,[1,.2,1,0]),P);

```

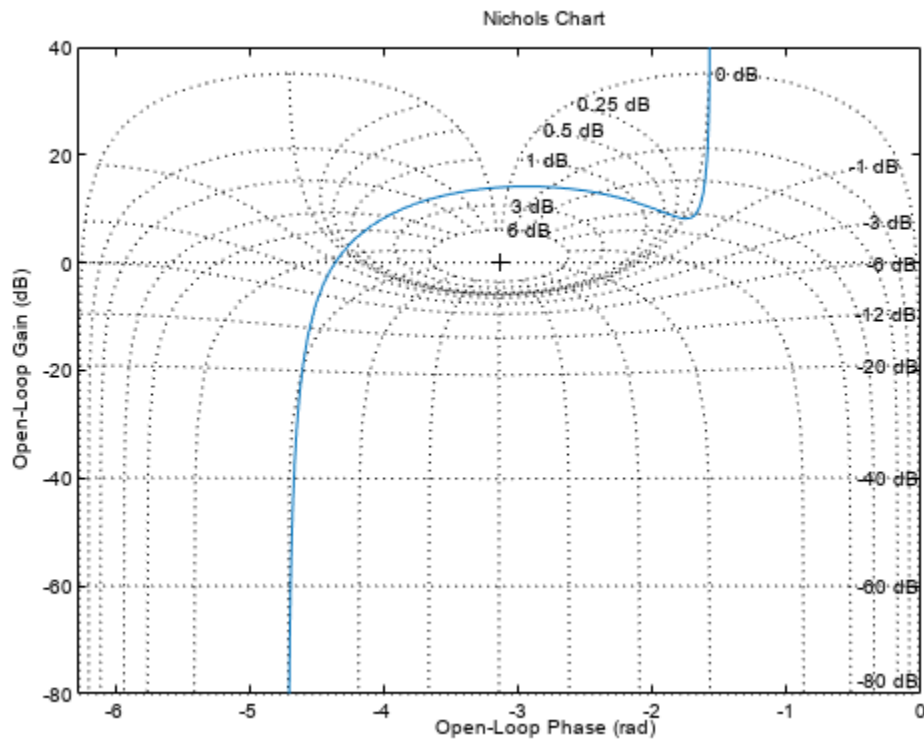

Version History

Introduced in R2008a

See Also

[getoptions](#) | [nicholsplot](#) | [setoptions](#)

Topics

“Toolbox Preferences Editor”

nicholsplot

Plot Nichols frequency responses with additional plot customization options

Syntax

```
h = nicholsplot(sys)
h = nicholsplot(sys1,sys2,...,sysN)
h = nicholsplot(sys1,LineStyle1,...,sysN,LineStyleN)
h = nicholsplot( ____,w)
h = nicholsplot(AX, ____)
h = nicholsplot( ____,plotoptions)
```

Description

`nicholsplot` lets you plot the Nichols frequency response of a dynamic system model with a broader range of plot customization options than `nichols`. You can use `nicholsplot` to obtain the plot handle and use it to customize the plot, such as modify the axes labels, limits and units. You can also use `nicholsplot` to draw a Nichols plot on an existing set of axes represented by an axes handle. To customize an existing Nichols plot using the plot handle:

- 1 Obtain the plot handle
- 2 Use `getoptions` to obtain the option set
- 3 Update the plot using `setoptions` to modify the required options

For more information, see “Customizing Response Plots from the Command Line”. To create Nichols plots with default options or to extract the Nichols frequency response data, use `nichols`.

`h = nicholsplot(sys)` plots the frequency Nichols response of the dynamic system model `sys` and returns the plot handle `h` to the plot. You can use this handle `h` to customize the plot with the `getoptions` and `setoptions` commands. If `sys` is a multi-input, multi-output (MIMO) model, then `nicholsplot` produces a grid of Nichols plots, each plot displaying the frequency response of one I/O pair.

`h = nicholsplot(sys1,sys2,...,sysN)` plots the Nichols frequency response of multiple dynamic systems `sys1,sys2,...,sysN` on the same plot. All systems must have the same number of inputs and outputs to use this syntax.

`h = nicholsplot(sys1,LineStyle1,...,sysN,LineStyleN)` sets the line style, marker type, and color for the Nichols response of each system. All systems must have the same number of inputs and outputs to use this syntax.

`h = nicholsplot(____,w)` plots Nichols responses for frequencies specified by the frequencies in `w`.

- If `w` is a cell array of the form `{wmin,wmax}`, then `nicholsplot` plots the response at frequencies ranging between `wmin` and `wmax`.
- If `w` is a vector of frequencies, then `nicholsplot` plots the response at each specified frequency.

You can use `w` with any of the input-argument combinations in previous syntaxes.

See `logspace` to generate logarithmically spaced frequency vectors.

`h = nicholsplot(AX, ___)` plots the Nichols response on the Axes object in the current figure with the handle AX.

`h = nicholsplot(___, plotoptions)` plots the Nichols frequency response with the options set specified in `plotoptions`. You can use these options to customize the Nichols plot appearance using the command line. Settings you specify in `plotoptions` overrides the preference settings in the MATLAB session in which you run `nicholsplot`. Therefore, this syntax is useful when you want to write a script to generate multiple plots that look the same regardless of the local preferences.

Examples

Customize Nichols Plot using Plot Handle

For this example, use the plot handle to change the title, turn on the grid, and set axis limits.

Generate a random state-space model with 5 states and create the Nichols plot with plot handle h.

```
rng("default")
sys = rss(5);
h = nicholsplot(sys);
```

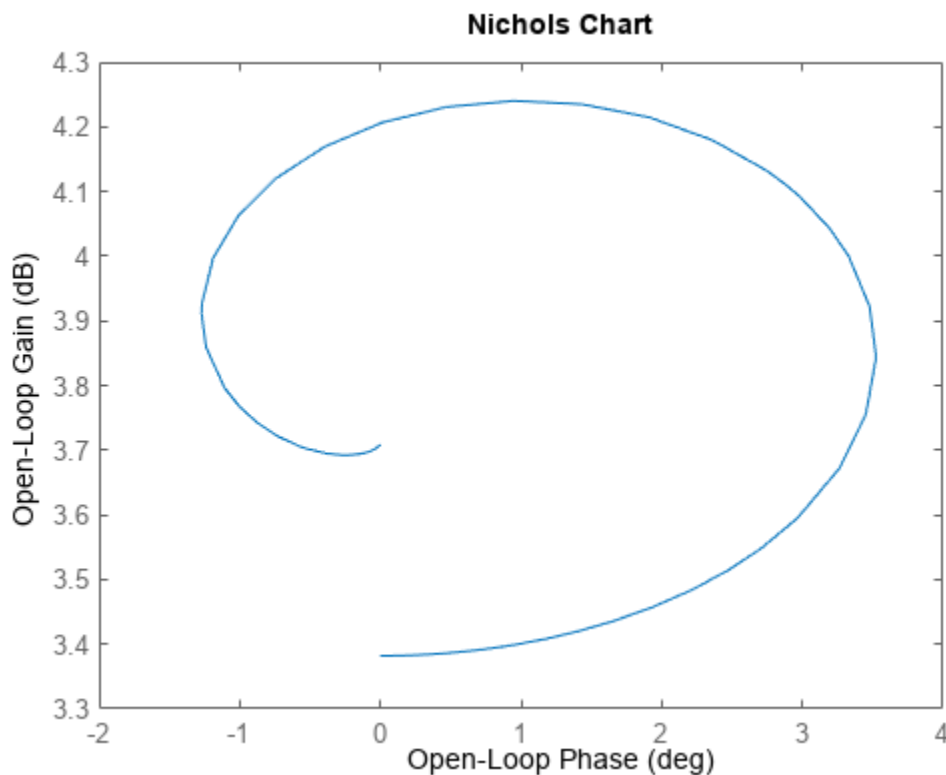

Change the title, enable the grid, and set axis limits. To do so, edit properties of the plot handle, h using `setoptions`.

```
Title.String = 'Nichols Frequency Response';  
setoptions(h, 'Title',Title, 'Grid', 'on', 'XLim',{[-2,4]}, 'YLim',{[3.3,4.3]});
```

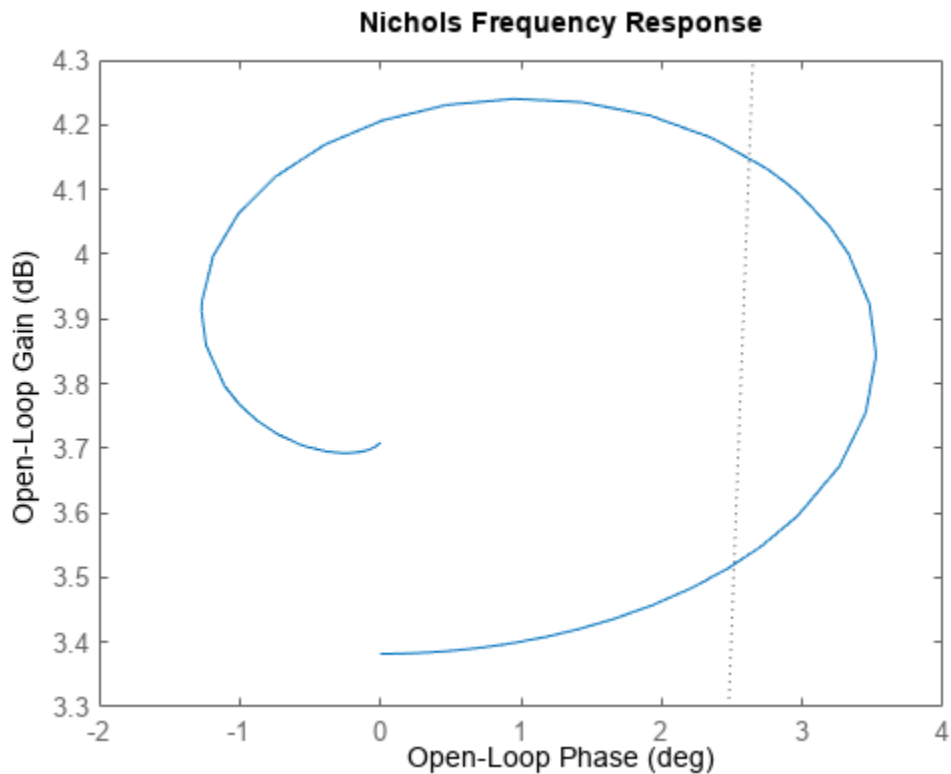

The Nichols plot automatically updates when you call `setoptions`.

Alternatively, you can also use the `nicholsoptions` command to specify the required plot options. First, create an options set based on the toolbox preferences.

```
plotoptions = nicholsoptions('cstprefs');
```

Change the desired properties of the options set.

```
plotoptions.Title.String = 'Nichols Frequency Response';  
plotoptions.Grid = 'on';  
plotoptions.XLim = {[-2,4]};  
plotoptions.YLim = {[3.3,4.3]};  
nicholsplot(sys,plotoptions);
```

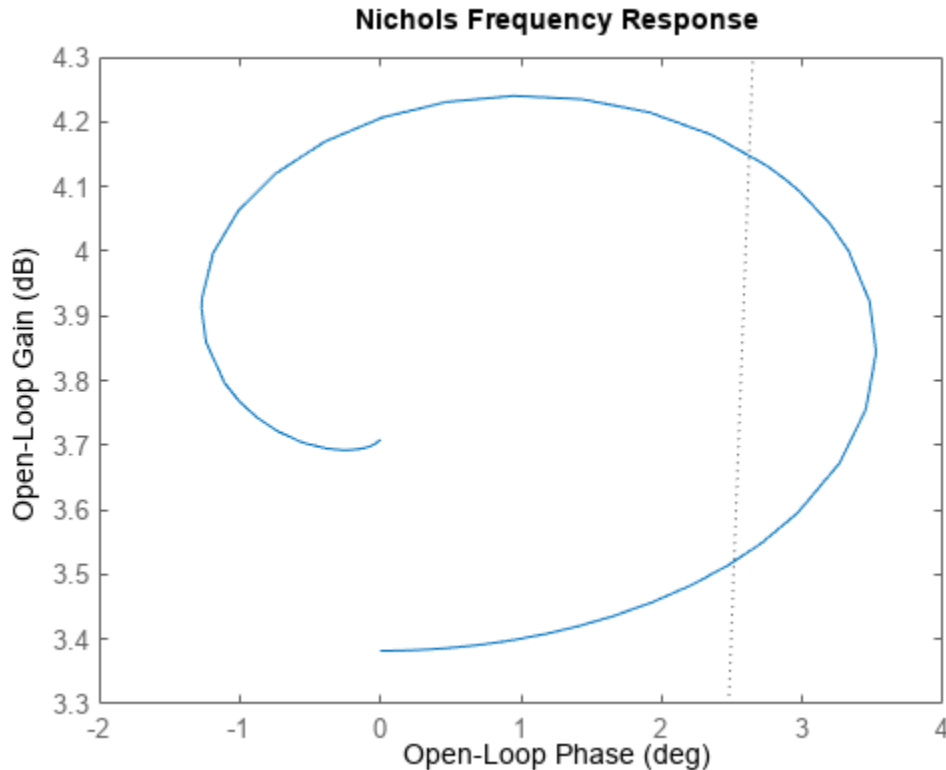
You can use the same option set to create multiple Nichols plots with the same customization. Depending on your own toolbox preferences, the plot you obtain might look different from this plot. Only the properties that you set explicitly, in this example `Title`, `Grid`, `XLim` and `YLim`, override the toolbox preferences.

Custom Nichols Plot Settings Independent of Preferences

For this example, create a Nichols plot that uses 15-point red text for the title. This plot should look the same, regardless of the preferences of the MATLAB session in which it is generated.

First, create a default options set using `nicholsoptions`.

```
plotoptions = nicholsoptions;
```

Next, change the required properties of the options set `plotoptions`.

```
plotoptions.Title.FontSize = 15;
plotoptions.Title.Color = [1 0 0];
plotoptions.FreqUnits = 'Hz';
plotoptions.Grid = 'on';
```

Now, create a Nichols plot using the options set `plotoptions`.

```
nicholsplot(tf(1,[1,1]),{0,15},plotoptions);
```

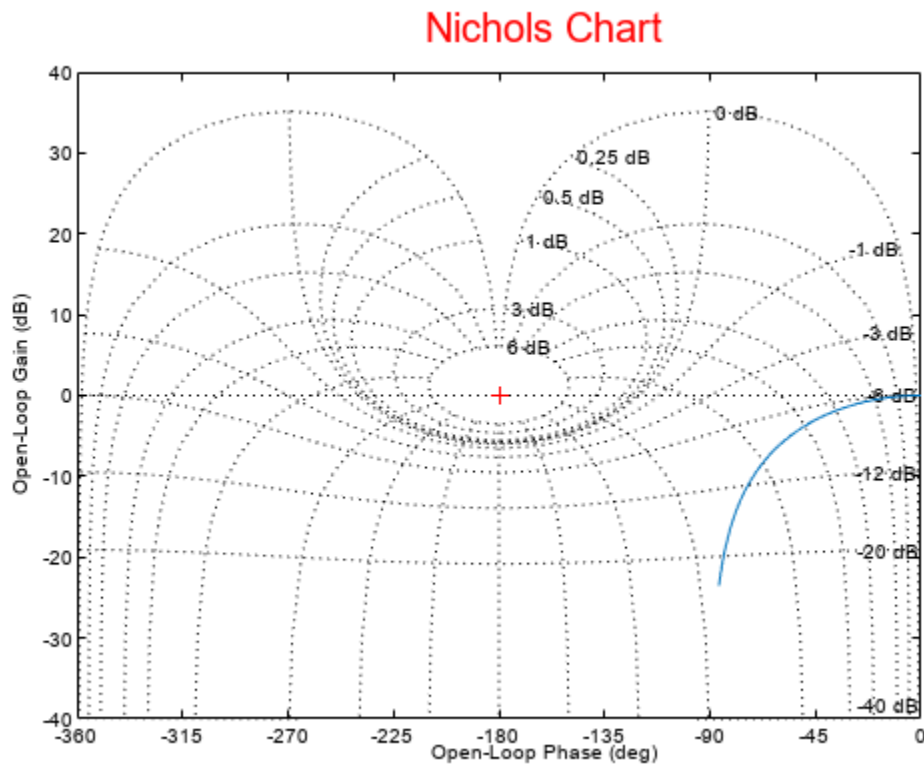

Because `plotoptions` begins with a fixed set of options, the plot result is independent of the toolbox preferences of the MATLAB session.

Customized Nichols Plot of Transfer Function

For this example, create a Nichols plot of the following continuous-time SISO dynamic system. Then, turn the grid on and rename the plot.

$$\text{sys}(s) = \frac{s^2 + 0.1s + 7.5}{s^4 + 0.12s^3 + 9s^2}$$

Create the transfer function `sys`.

```
sys = tf([1 0.1 7.5],[1 0.12 9 0 0]);
```

Next, create the options set using `nicholsoptions` and change the required plot properties.

```
plotoptions = nicholsoptions;
plotoptions.Grid = 'on';
plotoptions.Title.String = 'Nichols Plot of Transfer Function';
```

Now, create the Nichols plot with the custom option set `plotoptions`.

```
nicholsplot(sys,plotoptions)
```

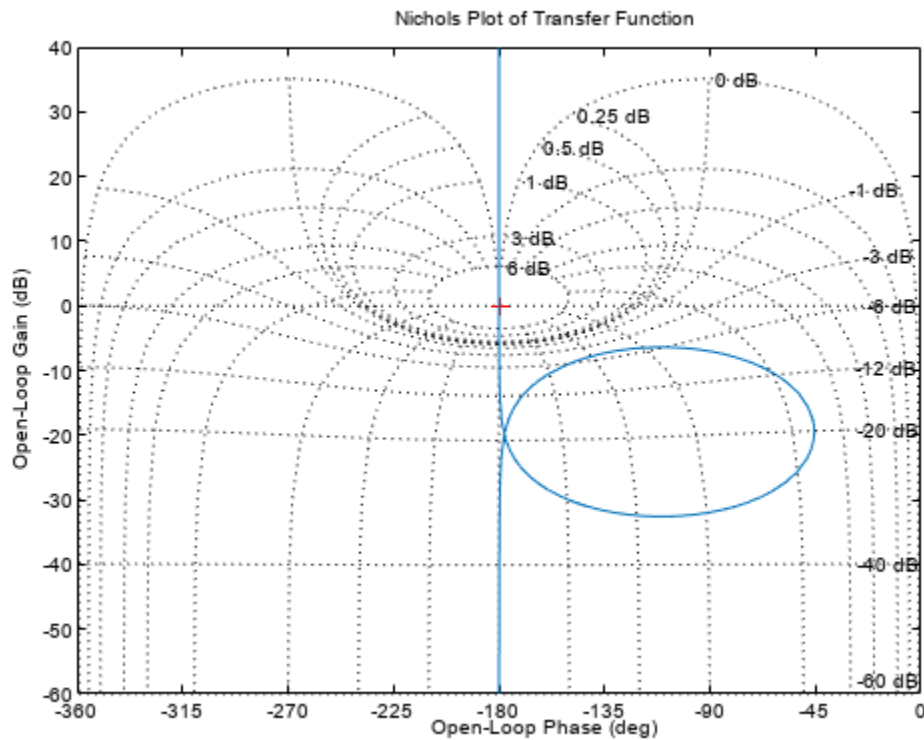

nicholsplot automatically selects the plot range based on the system dynamics.

Customized Nichols Plot of MIMO System

For this example, consider a MIMO state-space model with 3 inputs, 3 outputs and 3 states. Create a Nichols plot with frequency units in Hz and turn the grid on.

Create the MIMO state-space model `sys_mimo`.

```
J = [8 -3 -3; -3 8 -3; -3 -3 8];
F = 0.2*eye(3);
A = -J\F;
B = inv(J);
C = eye(3);
D = 0;
sys_mimo = ss(A,B,C,D);
size(sys_mimo)
```

State-space model with 3 outputs, 3 inputs, and 3 states.

Create a Nichols plot with plot handle `h` and use `getoptions` for a list of the options available.

```
h = nicholsplot(sys_mimo);
```

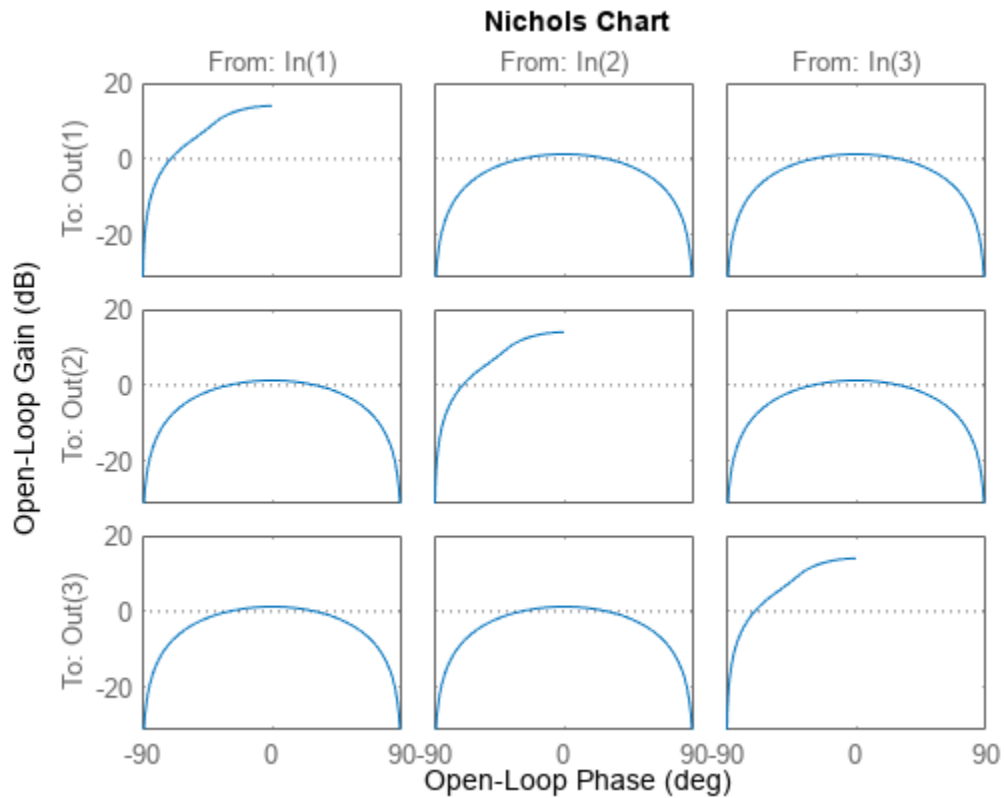

```
p = getoptions(h)
```

```
p =
```

```

    FreqUnits: 'rad/s'
    MagLowerLimMode: 'auto'
    MagLowerLim: 0
    PhaseUnits: 'deg'
    PhaseWrapping: 'off'
    PhaseMatching: 'off'
    PhaseMatchingFreq: 0
    PhaseMatchingValue: 0
    PhaseWrappingBranch: -180
    IOGrouping: 'none'
    InputLabels: [1x1 struct]
    OutputLabels: [1x1 struct]
    InputVisible: {3x1 cell}
    OutputVisible: {3x1 cell}
    Title: [1x1 struct]
    XLabel: [1x1 struct]
    YLabel: [1x1 struct]
    TickLabel: [1x1 struct]
    Grid: 'off'
    GridColor: [0.1500 0.1500 0.1500]
    XLim: {3x1 cell}
    YLim: {3x1 cell}
    XLimMode: {3x1 cell}
    YLimMode: {3x1 cell}

```

Use `setoptions` to update the plot with the requires customization.

```
setoptions(h, 'FreqUnits', 'Hz', 'Grid', 'on');
```

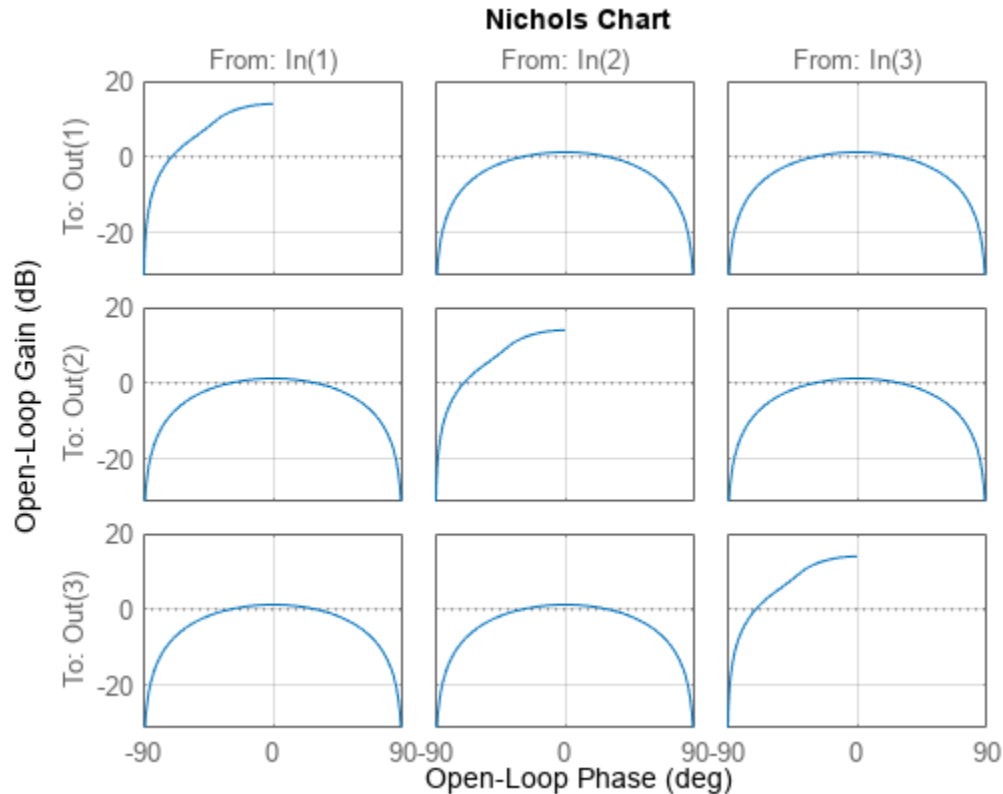

The Nichols plot automatically updates when you call `setoptions`. For MIMO models, `nicholsplot` produces an array of Nichols plots, each plot displaying the frequency response of one I/O pair.

Nichols Response of Identified Parametric and Nonparametric Models

For this example, compare the Nichols response of a parametric model, identified from input/output data, to a non-parametric model identified using the same data. Identify parametric and non-parametric models based on the data.

Load the data and create the parametric and non-parametric models using `tfest` and `spa`, respectively.

```
load iddata2 z2;
w = linspace(0,10*pi,128);
sys_np = spa(z2,[1],w);
sys_p = tfest(z2,2);
```

`spa` and `tfest` require System Identification Toolbox™ software. The model `sys_np` is a non-parametric identified model while, `sys_p` is a parametric identified model.

Create an options set to turn phase matching and the grid on. Then, create a Nichols plot that includes both systems using this options set.

```

plotoptions = nicholsoptions;
plotoptions.PhaseMatching = 'on';
plotoptions.Grid = 'on';
plotoptions.XLim = {[ -240,0]};
h = nicholsplot(sys_p,'r.-.',sys_np,'b.-.',w,plotoptions);
legend('Parametric Model','Non-Parametric model');

```

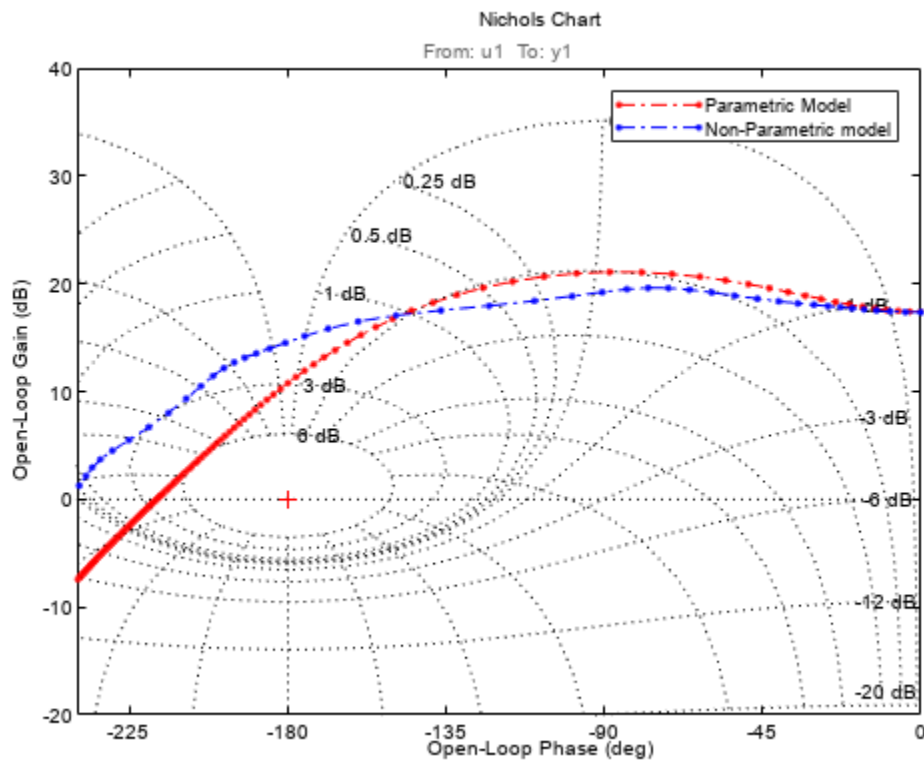

Input Arguments

sys — Dynamic system

dynamic system model | model array

Dynamic system, specified as a SISO or MIMO dynamic system model or array of dynamic system models. Dynamic systems that you can use include:

- Continuous-time or discrete-time numeric LTI models, such as `tf`, `zpk`, or `ss` models.
- Sparse state-space models, such as `sparss` or `mechss` models. Frequency grid `w` must be specified for sparse models.
- Generalized or uncertain LTI models such as `genss` or `uss` models. (Using uncertain models requires Robust Control Toolbox software.)

- For tunable control design blocks, the function evaluates the model at its current value to plot the frequency response data.
- For uncertain control design blocks, the function plots the nominal value and random samples of the model.
- Frequency-response data models such as `frd` models. For such models, the function plots the response at frequencies defined in the model.
- Identified LTI models, such as `idtf`, `idss`, or `idproc` models. For such models, the function can also plot confidence intervals and return standard deviations of the frequency response. (Using identified models requires System Identification Toolbox software.)

If `sys` is an array of models, the function plots the frequency responses of all models in the array on the same axes.

LineStyle — Line style, marker, and color

character vector | string

Line style, marker, and color, specified as a character vector or string containing symbols. The symbols can appear in any order. You do not need to specify all three characteristics (line style, marker, and color). For example, if you omit the line style and specify the marker, then the plot shows only the marker and no line.

Example: `'--or'` is a red dashed line with circle markers

Line Style	Description
-	Solid line
--	Dashed line
:	Dotted line
-.	Dash-dot line

Marker	Description
'o'	Circle
'+'	Plus sign
'*'	Asterisk
'.'	Point
'x'	Cross
'_'	Horizontal line
' '	Vertical line
's'	Square
'd'	Diamond
'^'	Upward-pointing triangle
'v'	Downward-pointing triangle
'>'	Right-pointing triangle
'<'	Left-pointing triangle
'p'	Pentagram

Marker	Description
'h'	Hexagram

Color	Description
y	yellow
m	magenta
c	cyan
r	red
g	green
b	blue
w	white
k	black

AX — Target axes

Axes object

Target axes, specified as an Axes object. If you do not specify the axes and if the current axes are Cartesian axes, then `nicholsplot` plots on the current axes. Use AX to plot into specific axes.

plotoptions — Nichols plot options set

NicholsPlotOptions object

Nichols plot options set, specified as a NicholsPlotOptions object. You can use this option set to customize the Nichols plot appearance. Use `nicholsoptions` to create the option set. Settings you specify in `plotoptions` overrides the preference settings in the MATLAB session in which you run `nicholsplot`. Therefore, `plotoptions` is useful when you want to write a script to generate multiple plots that look the same regardless of the local preferences.

For the list of available options, see `nicholsoptions`.

w — Frequencies

{wmin,wmax} | vector

Frequencies at which to compute and plot frequency response, specified as the cell array {wmin,wmax} or as a vector of frequency values.

- If w is a cell array of the form {wmin,wmax}, then the function computes the response at frequencies ranging between wmin and wmax.
- If w is a vector of frequencies, then the function computes the response at each specified frequency. For example, use `logspace` to generate a row vector with logarithmically spaced frequency values.

Specify frequencies in units of rad/TimeUnit, where TimeUnit is the TimeUnit property of the model.

Output Arguments**h — Plot handle**

handle object

Plot handle, returned as a `handle` object. Use the handle `h` to get and set the properties of the Nichols plot using `getoptions` and `setoptions`. For the list of available options, see the *Properties and Values Reference* section in “Customizing Response Plots from the Command Line”.

Version History

Introduced before R2006a

See Also

`getoptions` | `nichols` | `nicholsoptions` | `setoptions`

Topics

“Customizing Response Plots from the Command Line”

nmodels

Number of models in model array

Syntax

```
N = nmodels(sysarray)
```

Description

`N = nmodels(sysarray)` returns the number of models in an array of dynamic system models or static models.

Examples

Confirm Number of Models in Array

Create a 2-by-3-by-4 array of state-space models.

```
sysarr = rss(2,2,2,2,3,4);
```

Confirm the number of models in the array.

```
N = nmodels(sysarr)
```

```
N = 24
```

Input Arguments

sysarray — Input model array

model array

Input model array, specified as an array of input-output models such as numeric LTI models, generalized models, or identified LTI models.

Output Arguments

N — Number of models in array

positive integer

Number of models in the input model array, returned as a positive integer.

Version History

Introduced in R2013a

See Also

[ndims](#) | [size](#)

norm

Norm of linear model

Syntax

```
n = norm(sys)
n = norm(sys,2)

n = norm(sys,Inf)
[n, fpeak] = norm(sys,Inf)
[n, fpeak] = norm(sys,Inf, tol)
```

Description

`n = norm(sys)` or `n = norm(sys,2)` returns the root-mean-squares of the impulse response of the linear dynamic system model `sys`. This value is equivalent to the H_2 norm on page 2-812 of `sys`.

`n = norm(sys,Inf)` returns the L_∞ norm on page 2-812 of `sys`, which is the peak gain of the frequency response of `sys` across frequencies. For MIMO systems, this quantity is the peak gain over all frequencies and all input directions, which corresponds to the peak value of the largest singular value of `sys`. For stable systems, the L_∞ norm is equivalent to the H_∞ norm. For more information, see `hinfnorm`.

`[n, fpeak] = norm(sys,Inf)` also returns the frequency `fpeak` at which the gain reaches its peak value.

`[n, fpeak] = norm(sys,Inf, tol)` sets the relative accuracy of the L_∞ norm to `tol`.

Examples

Compute Norm of Discrete-Time Linear System

Compute the H_2 and L_∞ norms of the following discrete-time transfer function, with sample time 0.1 second.

$$\text{sys}(z) = \frac{z^3 - 2.841z^2 + 2.875z - 1.004}{z^3 - 2.417z^2 + 2.003z - 0.5488}$$

Compute the H_2 norm of the transfer function. The H_2 norm is the root-mean-square of the impulse response of `sys`.

```
sys = tf([1 -2.841 2.875 -1.004],[1 -2.417 2.003 -0.5488],0.1);
n2 = norm(sys)
```

```
n2 = 1.2438
```

Compute the L_∞ norm of the transfer function.

```
[ninf, fpeak] = norm(sys,Inf)
```

```
ninf = 2.5721
fpeak = 3.0178
```

Because `sys` is a stable system, `ninf` is the peak gain of the frequency response of `sys`, and `fpeak` is the frequency at which the peak gain occurs. Confirm these values using `getPeakGain`.

```
[gpeak, fpeak] = getPeakGain(sys)
gpeak = 2.5721
fpeak = 3.0178
```

Input Arguments

sys — Dynamic system

dynamic system model | model array

Input dynamic system, specified as any SISO or MIMO linear dynamic system model or model array. `sys` can be continuous-time or discrete-time.

tol — Relative accuracy

0.01 (default) | positive real scalar

Relative accuracy of the H_∞ norm, specified as a positive real scalar value.

Output Arguments

n — H_2 or L_∞ norm

scalar | array

H_2 norm or L_∞ norm of `sys`, returned as a scalar or an array.

- If `sys` is a single model, then `n` is a scalar value.
- If `sys` is a model array, then `n` is an array of the same size as `sys`, where `n(k) = norm(sys(:, :, k))`.

fpeak — Frequency of peak gain

real scalar | array of real values

Frequency at which the gain achieves the peak value `gpeak`, returned as a real scalar value or an array of real values. The frequency is expressed in units of `rad/TimeUnit`, relative to the `TimeUnit` property of `sys`.

- If `sys` is a single model, then `fpeak` is a scalar.
- If `sys` is a model array, then `fpeak` is an array of the same size as `sys`, where `fpeak(k)` is the peak gain frequency of `sys(:, :, k)`.

`fpeak` can be negative for systems with complex coefficients.

More About

H2 norm

The H_2 norm of a stable system H is the root-mean-square of the impulse response of the system. The H_2 norm measures the steady-state covariance (or power) of the output response $y = Hw$ to unit white noise inputs w :

$$\|H\|_2^2 = \lim_{t \rightarrow \infty} E\{y(t)^T y(t)\}, \quad E(w(t)w(\tau)^T) = \delta(t - \tau)I.$$

The H_2 norm of a continuous-time system with transfer function $H(s)$ is given by:

$$\|H\|_2 = \sqrt{\frac{1}{2\pi} \int_{-\infty}^{\infty} \text{Trace}[H(j\omega)^H H(j\omega)] d\omega}.$$

For a discrete-time system with transfer function $H(z)$, the H_2 norm is given by:

$$\|H\|_2 = \sqrt{\frac{1}{2\pi} \int_{-\pi}^{\pi} \text{Trace}[H(e^{j\omega})^H H(e^{j\omega})] d\omega}.$$

The H_2 norm is infinite in the following cases:

- `sys` is unstable.
- `sys` is continuous and has a nonzero feedthrough (that is, nonzero gain at the frequency $\omega = \infty$).

Using `norm(sys)` produces the same result as `sqrt(trace(covar(sys,1)))`.

L-infinity norm

The L_∞ norm of a SISO linear system is the peak gain of the frequency response. For a MIMO system, the L_∞ norm is the peak gain across all input/output channels.

For a continuous-time system $H(s)$, this definition means:

$$\|H(s)\|_{L_\infty} = \max_{\omega \in R} |H(j\omega)| \quad (\text{SISO})$$

$$\|H(s)\|_{L_\infty} = \max_{\omega \in R} \sigma_{\max}(H(j\omega)) \quad (\text{MIMO})$$

where $\sigma_{\max}(\cdot)$ denotes the largest singular value of a matrix.

For a discrete-time system $H(z)$, the definition means:

$$\|H(z)\|_{L_\infty} = \max_{\theta \in [0, 2\pi]} |H(e^{j\theta})| \quad (\text{SISO})$$

$$\|H(z)\|_{L_\infty} = \max_{\theta \in [0, 2\pi]} \sigma_{\max}(H(e^{j\theta})) \quad (\text{MIMO})$$

For stable systems, the L_∞ norm is equivalent to the H_∞ norm. For more information, see `hinfnorm`. For a system with unstable poles, the H_∞ norm is infinite. For all systems, `norm` returns the L_∞ norm, which is the peak gain without regard to system stability.

Algorithms

After converting `sys` to a state space model, `norm` uses the same algorithm as `covar` for the H_2 norm. For the L_∞ norm, `norm` uses the algorithm of [1]. `norm` computes the peak gain using the SLICOT library. For more information about the SLICOT library, see <http://slicot.org>.

Version History

Introduced before R2006a

References

[1] Bruinsma, N.A., and M. Steinbuch. "A Fast Algorithm to Compute the H_∞ Norm of a Transfer Function Matrix." *Systems & Control Letters*, 14, no.4 (April 1990): 287-93.

See Also

`freqresp` | `sigma` | `getPeakGain` | `hinfnorm`

nyquist

Nyquist plot of frequency response

Syntax

```
nyquist(sys)
nyquist(sys1,sys2,...,sysN)
nyquist(sys1,LineStyle1,...,sysN,LineStyleN)
nyquist( __ ,w)
```

```
[re,im,wout] = nyquist(sys)
[re,im,wout] = nyquist(sys,w)
[re,im,wout,sdre,sdim] = nyquist(sys,w)
```

Description

`nyquist(sys)` creates a Nyquist plot of the frequency response of a dynamic system model `sys`. The plot displays real and imaginary parts of the system response as a function of frequency.

`nyquist` plots a contour comprised of both positive and negative frequencies. The plot also shows arrows to indicate the direction of increasing frequency for each branch. `nyquist` automatically determines frequencies to plot based on system dynamics.

If `sys` is a multi-input, multi-output (MIMO) model, then `nyquist` produces an array of Nyquist plots, each plot showing the frequency response of one I/O pair.

If `sys` is a model with complex coefficients, then the positive and negative branches are not symmetric.

`nyquist(sys1,sys2,...,sysN)` plots the frequency response of multiple dynamic systems on the same plot. All systems must have the same number of inputs and outputs.

`nyquist(sys1,LineStyle1,...,sysN,LineStyleN)` specifies a color, line style, and marker for each system in the plot.

`nyquist(__ ,w)` plots system responses for frequencies specified by `w`.

- If `w` is a cell array of the form `{wmin,wmax}`, then `nyquist` plots the response at frequencies ranging between `wmin` and `wmax`.
- If `w` is a vector of frequencies, then `nyquist` plots the response at each specified frequency. The vector `w` can contain both negative and positive frequencies.

You can use `w` with any of the input-argument combinations in previous syntaxes.

`[re,im,wout] = nyquist(sys)` returns the real and imaginary parts of the frequency response at each frequency in the vector `wout`. The function automatically determines frequencies in `wout` based on system dynamics. This syntax does not draw a plot.

`[re,im,wout] = nyquist(sys,w)` returns the response data at the frequencies specified by `w`.

- If w is a cell array of the form $\{w_{min}, w_{max}\}$, then w_{out} contains frequencies ranging between w_{min} and w_{max} .
- If w is a vector of frequencies, then $w_{out} = w$.

$[re, im, w_{out}, s_{dre}, s_{dim}] = \text{nyquist}(sys, w)$ also returns the estimated standard deviation of the real and imaginary parts of the frequency response for the identified model sys . If you omit w , then the function automatically determines frequencies in w_{out} based on system dynamics.

Examples

Nyquist Plot of Dynamic System

Create the following transfer function and plot its Nyquist response.

$$H(s) = \frac{2s^2 + 5s + 1}{s^2 + 2s + 3}$$

```
H = tf([2 5 1],[1 2 3]);
nyquist(H)
```

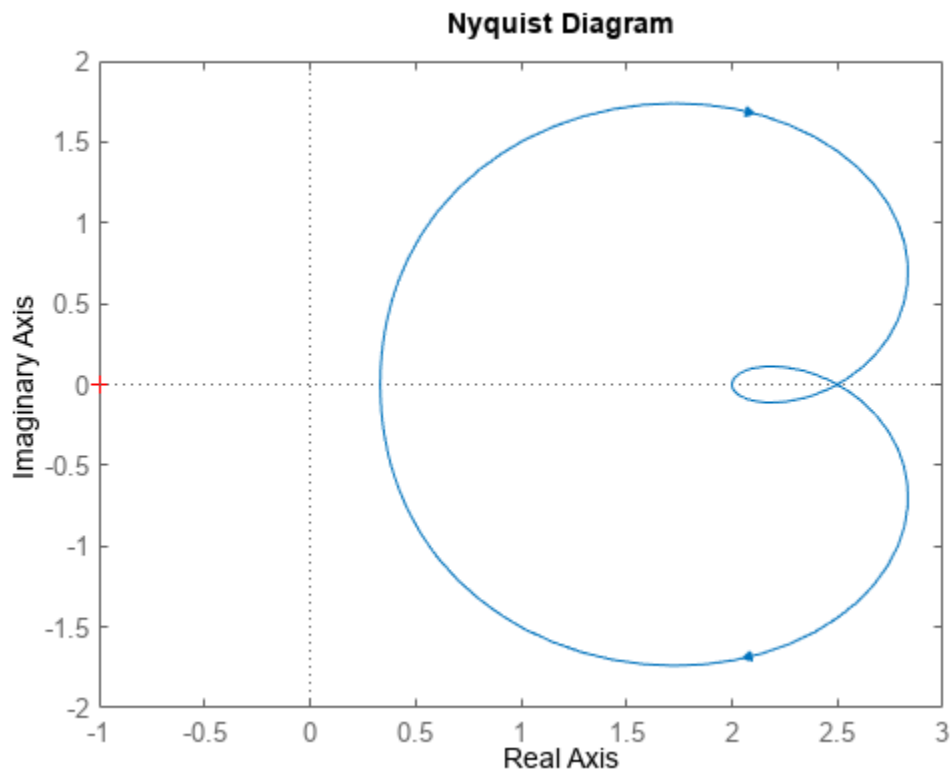

The `nyquist` function can display a grid of M -circles, which are the contours of constant closed-loop magnitude. M -circles are defined as the locus of complex numbers where the following quantity is a constant value across frequency.

$$T(j\omega) = \left| \frac{G(j\omega)}{1+G(j\omega)} \right|.$$

Here, ω is the frequency in radians/TimeUnit, where TimeUnit is the system time units, and G is the collection of complex numbers that satisfy the constant magnitude requirement.

To display the grid of M -circles, right-click in the plot and select **Grid**. Alternatively, use the `grid` command.

`grid on`

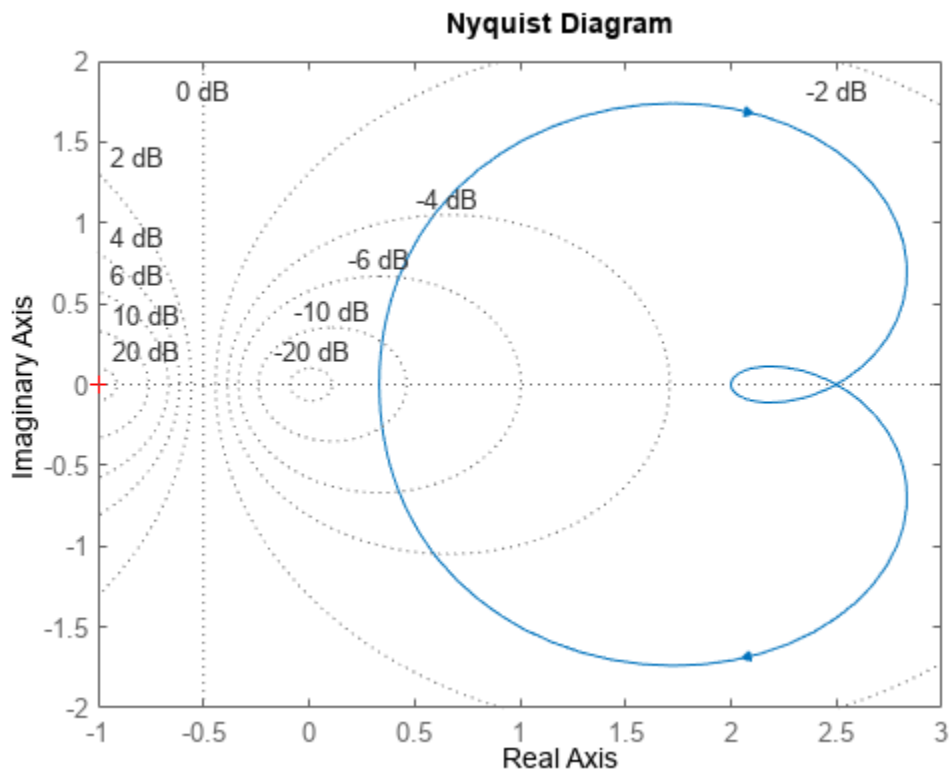

Nyquist Plot at Specified Frequencies

Create a Nyquist plot over a specified frequency range. Use this approach when you want to focus on the dynamics in a particular range of frequencies.

```
H = tf([-0.1, -2.4, -181, -1950], [1, 3.3, 990, 2600]);
nyquist(H, {1, 100})
```

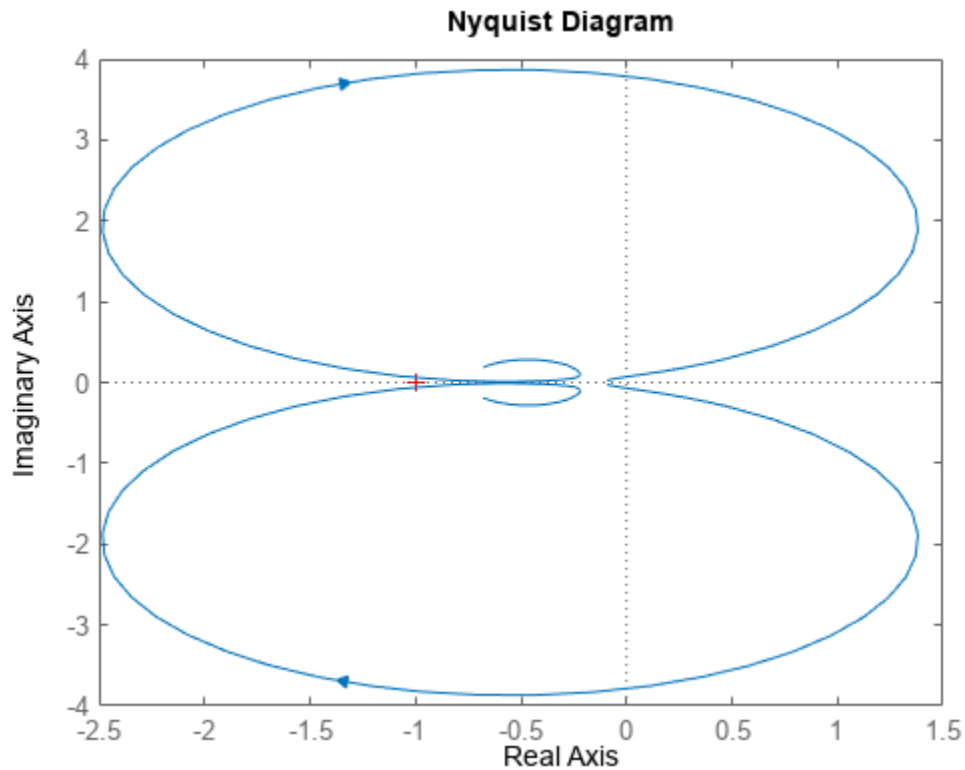

The cell array `{1, 100}` specifies a frequency range `[1,100]` for the positive frequency branch and `[-100,-1]` for the negative frequency branch in the Nyquist plot. The negative frequency branch is obtained by symmetry for models with real coefficients. When you provide frequency bounds in this way, the function selects intermediate points for frequency response data.

Alternatively, specify a vector of frequency points to use for evaluating and plotting the frequency response.

```
w = 1:0.1:30;  
nyquist(H,w, '-')
```

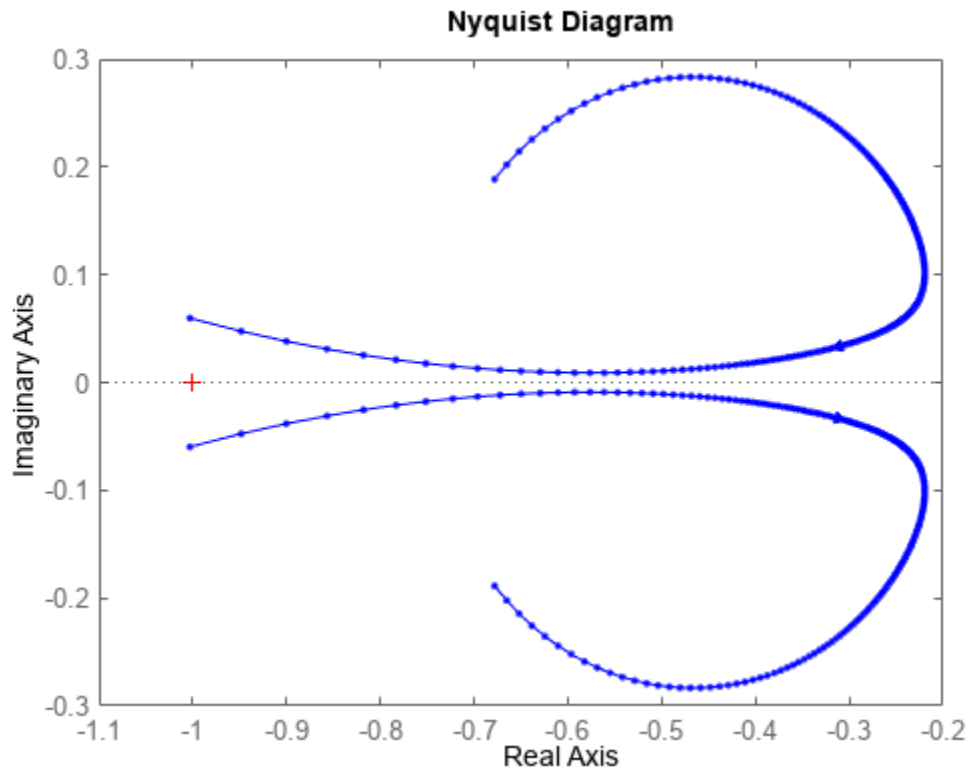

`nyquist` plots the frequency response at the specified frequencies.

Nyquist Plot of Several Dynamic Systems

Compare the frequency response of several systems on the same Nyquist plot.

Create the dynamic systems.

```
rng(0)
sys1 = tf(3,[1,2,1]);
sys2 = tf([2 5 1],[1 2 3]);
sys3 = rss(4);
```

Create a Nyquist plot that displays all systems.

```
nyquist(sys1,sys2,sys3)
legend('Location','southwest')
```

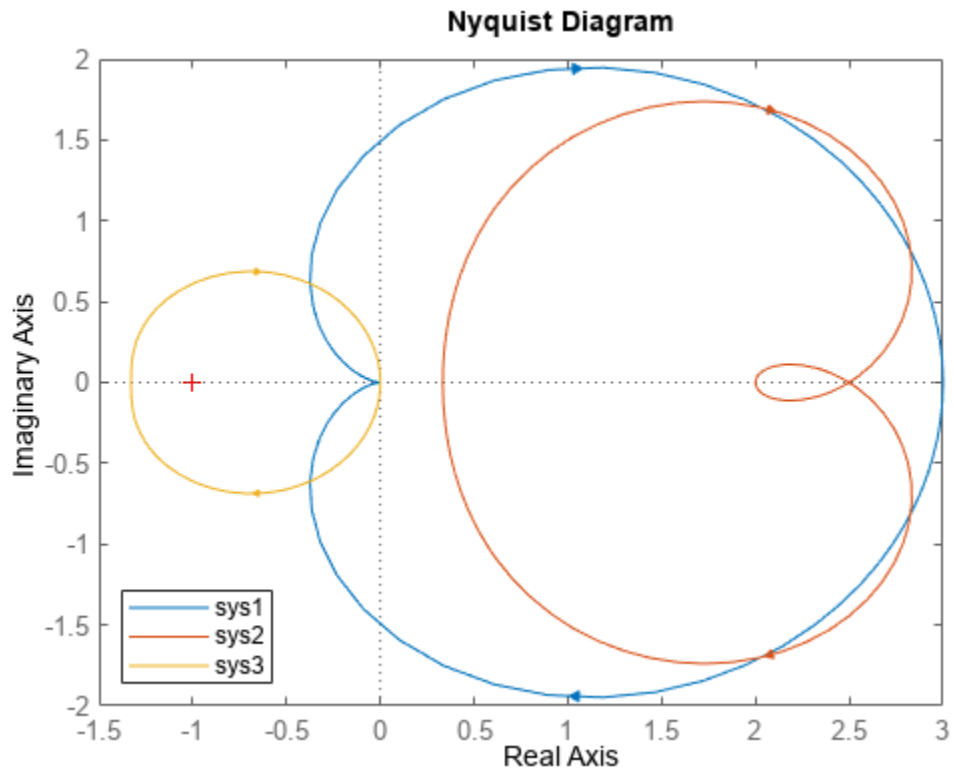

Nyquist Plot with Specified Line Attributes

Specify the line style, color, or marker for each system in a Nyquist plot using the LineSpec input argument.

```
sys1 = tf(3,[1,2,1]);  
sys2 = tf([2 5 1],[1 2 3]);  
nyquist(sys1, 'o:',sys2, 'g')
```

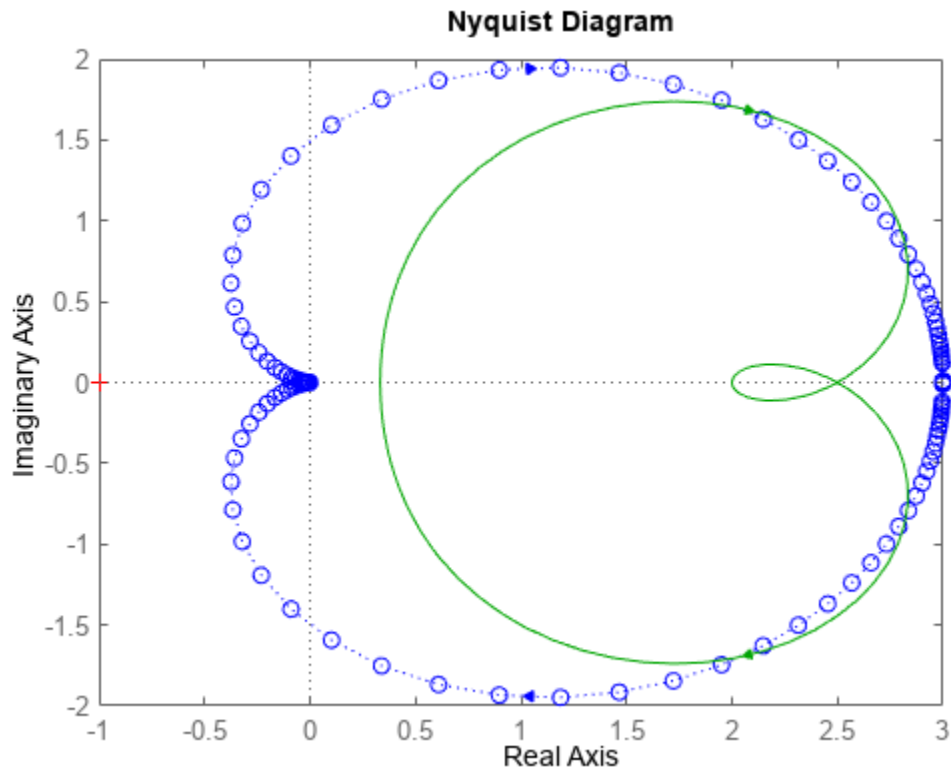

The first LineSpec, 'o:', specifies a dotted line with circle markers for the response of sys1. The second LineSpec, 'g', specifies a solid green line for the response of sys2.

Obtain Real and Imaginary Parts of Frequency Response

Compute the real and imaginary parts of the frequency response of a SISO system.

If you do not specify frequencies, `nyquist` chooses frequencies based on the system dynamics and returns them in the third output argument.

```
H = tf([2 5 1],[1 2 3]);
[re,im,wout] = nyquist(H);
```

Because `H` is a SISO model, the first two dimensions of `re` and `im` are both 1. The third dimension is the number of frequencies in `wout`.

```
size(re)
```

```
ans = 1×3
```

```
1 1 141
```

```
length(wout)
```

```
ans = 141
```

Thus, each entry along the third dimension of `re` gives the real part of the response at the corresponding frequency in `wout`.

Nyquist Plot of MIMO System

For this example, create a 2-output, 3-input system.

```
rng(0, 'twister');
H = rss(4,2,3);
```

For this system, `nyquist` plots the frequency responses of each I/O channel in a separate plot in a single figure.

```
nyquist(H)
```

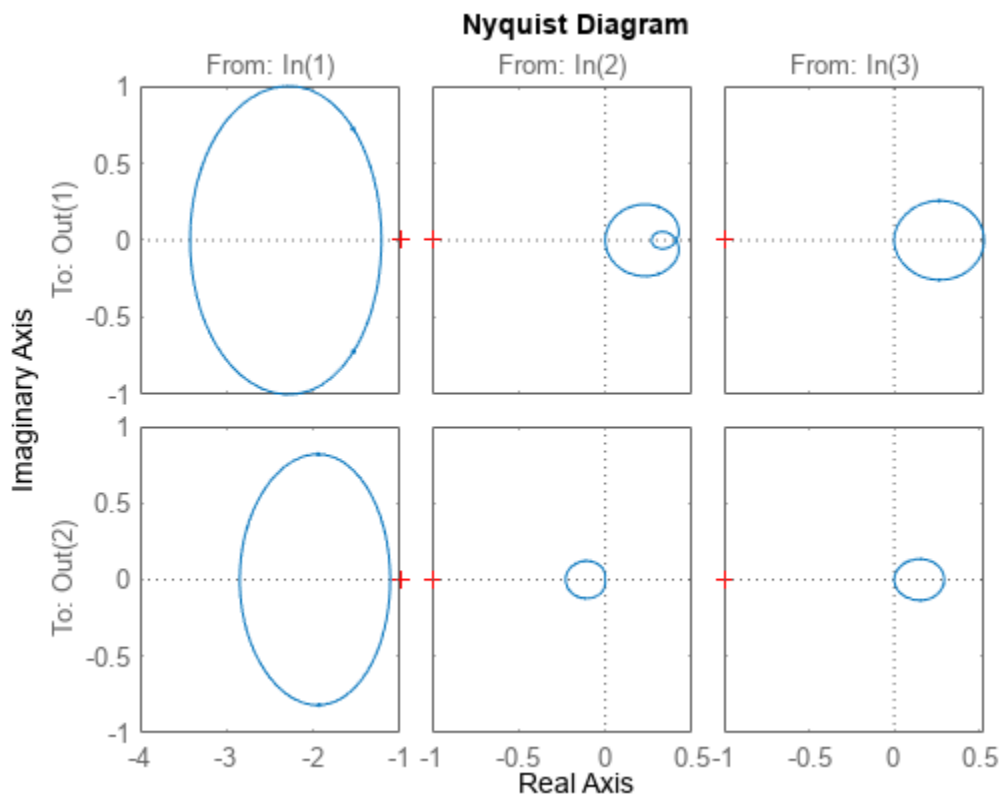

Compute the real and imaginary parts of these responses at 20 frequencies between 1 and 10 radians.

```
w = logspace(0,1,20);
[re,im] = nyquist(H,w);
```

`re` and `im` are three-dimensional arrays, in which the first two dimensions correspond to the output and input dimensions of `H`, and the third dimension is the number of frequencies. For instance, examine the dimensions of `re`.

```
size(re)
ans = 1×3
      2      3     20
```

Thus, for example, `re(1,3,10)` is the real part of the response from the third input to the first output, computed at the 10th frequency in `w`. Similarly, `im(1,3,10)` contains the imaginary part of the same response.

Create Nyquist Plot of Identified Model With Response Uncertainty

Compute the standard deviations of the real and imaginary parts of the frequency response of an identified model. Use this data to create a 3σ plot of the response uncertainty.

Load the estimation data `z2`.

```
load iddata2 z2;
```

Identify a transfer function model using the data. Using the `tfest` command requires System Identification Toolbox™ software.

```
sys_p = tfest(z2,2);
```

Obtain the standard deviations for the real and imaginary parts of the frequency response for a set of 512 frequencies, `w`.

```
w = linspace(-10*pi,10*pi,512);
[re,im,wout,sdre,sdim] = nyquist(sys_p,w);
```

`re` and `im` are the real and imaginary parts of the frequency response, and `sdre` and `sdim` are their standard deviations, respectively. The frequencies in `wout` are the same as the frequencies you specified in `w`.

Use the standard deviation data to create a 3σ plot corresponding to the confidence region.

```
re = squeeze(re);
im = squeeze(im);
sdre = squeeze(sdre);
sdim = squeeze(sdim);
plot(re,im,'b',re+3*sdre,im+3*sdim,'k:',re-3*sdre,im-3*sdim,'k:')
xlabel('Real Axis');
ylabel('Imaginary Axis');
```

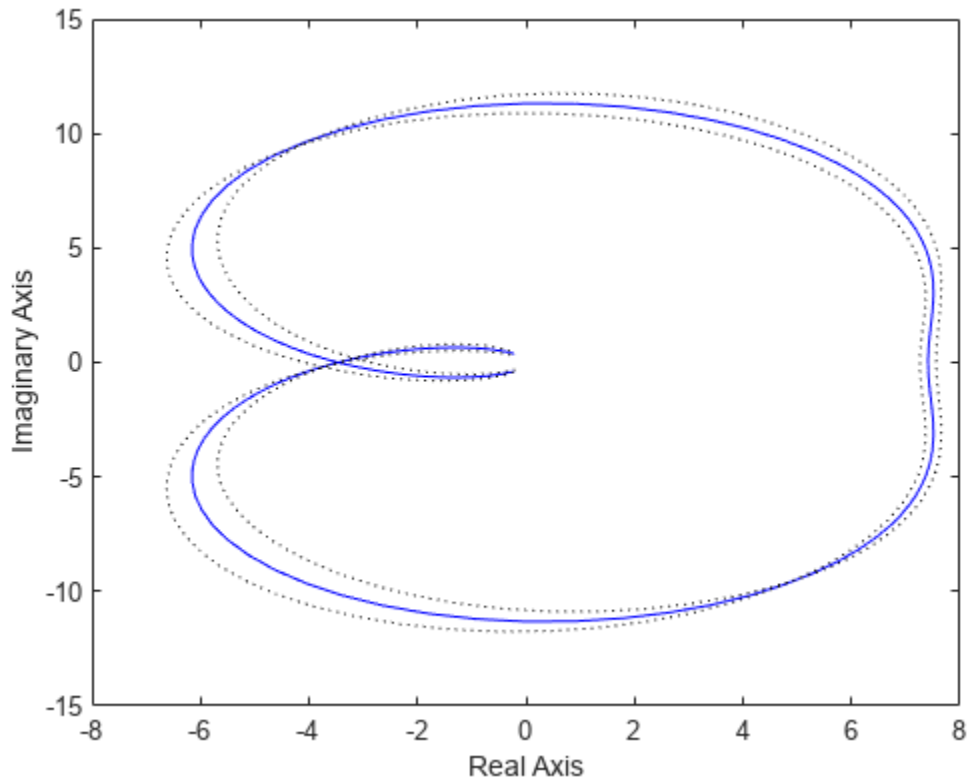
Nyquist Plot of Model with Complex Coefficients

Create a Nyquist plot of a model with complex coefficients and a model with real coefficients on the same plot.

```
rng(0)
A = [-3.50, -1.25-0.25i; 2, 0];
B = [1; 0];
C = [-0.75-0.5i, 0.625-0.125i];
D = 0.5;
Gc = ss(A,B,C,D);
Gr = rss(4);
nyquist(Gc,Gr)
legend('Complex-coefficient model', 'Real-coefficient model')
```

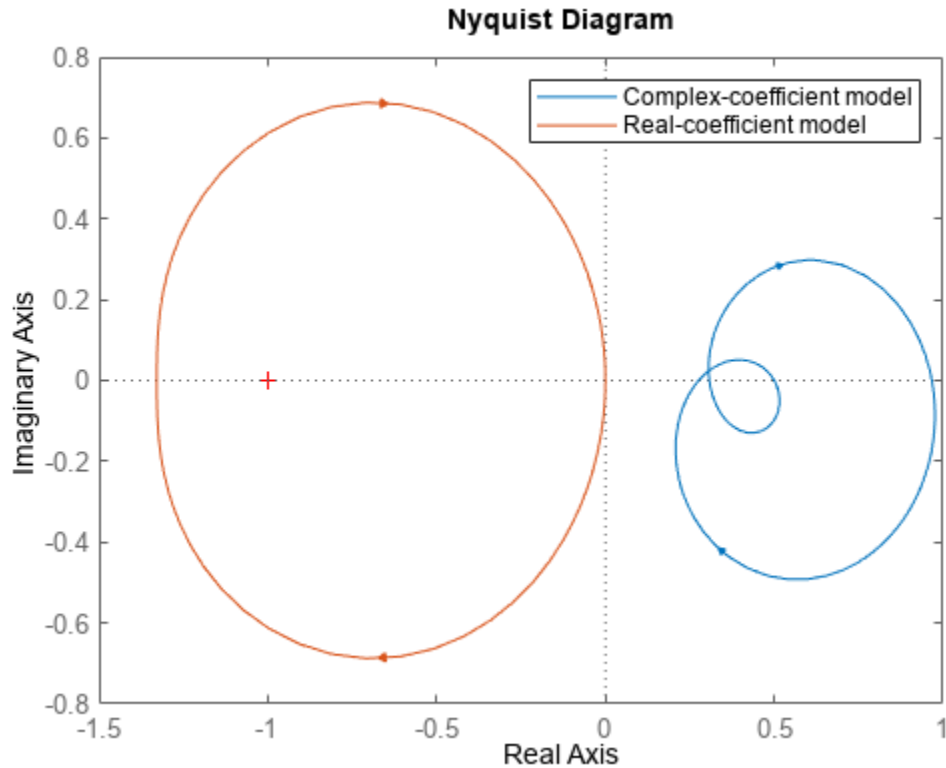

The Nyquist plot always shows two branches, one for positive frequencies and one for negative frequencies. The arrows indicate the direction of increasing frequency for each branch. For models with complex coefficients, the two branches are not symmetric. For models with real coefficients, the negative branch is obtained by symmetry.

Input Arguments

sys — Dynamic system

dynamic system model | model array

Dynamic system, specified as a SISO or MIMO dynamic system model or array of dynamic system models. Dynamic systems that you can use include:

- Continuous-time or discrete-time numeric LTI models, such as `tf`, `zpk`, or `ss` models.
- Generalized or uncertain LTI models such as `genss` or `uss` models. (Using uncertain models requires Robust Control Toolbox software.)
 - For tunable control design blocks, the function evaluates the model at its current value for both plotting and returning frequency response data.
 - For uncertain control design blocks, the function plots the nominal value and random samples of the model. When you use output arguments, the function returns frequency response data for the nominal model only.
- Frequency-response data models such as `frd` models. For such models, the function plots the response at frequencies defined in the model.

- Identified LTI models, such as `idtf`, `idss`, or `idproc` models. For such models, the function can also plot confidence intervals and return standard deviations of the frequency response. See “Create Nyquist Plot of Identified Model With Response Uncertainty” on page 2-822. (Using identified models requires System Identification Toolbox software.)

If `sys` is an array of models, the function plots the frequency responses of all models in the array on the same axes.

LineStyle — Line style, marker, and color

character vector | string

Line style, marker, and color, specified as a string or vector of one, two, or three characters. The characters can appear in any order. You do not need to specify all three characteristics (line style, marker, and color). For example, if you omit the line style and specify the marker, then the plot shows only the marker and no line. For more information about configuring this argument, see the `LineStyle` input argument of the `plot` function.

Example: `'r--'` specifies a red dashed line

Example: `'*b'` specifies blue asterisk markers

Example: `'y'` specifies a yellow line

w — Frequencies

{`wmin`, `wmax`} | vector

Frequencies at which to compute and plot frequency response, specified as the cell array `{wmin, wmax}` or as a vector of frequency values.

- If `w` is a cell array of the form `{wmin, wmax}`, then the function computes the response at frequencies ranging between `wmin` and `wmax`.
- If `w` is a vector of frequencies, then the function computes the response at each specified frequency. For example, use `logspace` to generate a row vector with logarithmically spaced frequency values. The vector `w` can contain both positive and negative frequencies.

If you specify a frequency range of `[wmin, wmax]` for your plot, then the plot shows a contour comprised of both positive frequencies `[wmin, wmax]` and negative frequencies `[-wmax, -wmin]`.

Specify frequencies in units of `rad/TimeUnit`, where `TimeUnit` is the `TimeUnit` property of the model.

Output Arguments

re — Real part of system response

3-D array

Real part of the system response, returned as a 3-D array. The dimensions of this array are (number of system outputs)-by-(number of system inputs)-by-(number of frequency points).

- For SISO systems, `re(1, 1, k)` gives the real part of the response at the `k`th frequency in `w` or `wout`. For an example, see “Obtain Real and Imaginary Parts of Frequency Response” on page 2-820.
- For MIMO systems, `re(i, j, k)` gives the real part of the response at the `k`th frequency from the `j`th input to the `i`th output. For an example, see “Nyquist Plot of MIMO System” on page 2-821.

im — Imaginary part of system response

3-D array

Imaginary part of the system response, returned as a 3-D array. The dimensions of this array are (number of system outputs)-by-(number of system inputs)-by-(number of frequency points).

- For SISO systems, `im(1,1,k)` gives the imaginary part of the response at the k th frequency in `w` or `wout`. For an example, see “Obtain Real and Imaginary Parts of Frequency Response” on page 2-820.
- For MIMO systems, `im(i,j,k)` gives the imaginary part of the response at the k th frequency from the j th input to the i th output. For an example, see “Nyquist Plot of MIMO System” on page 2-821.

wout — Frequencies

vector

Frequencies at which the function returns the system response, returned as a column vector. The function chooses the frequency values based on the model dynamics, unless you specify frequencies using the input argument `w`.

`wout` also contains negative frequency values for models with complex coefficients.

Frequency values are in radians per `TimeUnit`, where `TimeUnit` is the value of the `TimeUnit` property of `sys`.

sdre — Standard deviation of real part

3-D array | []

Estimated standard deviation of the real part of the response at each frequency point, returned as a 3-D array. `sdre` has the same dimensions as `re`.

If `sys` is not an identified LTI model, `sdre` is `[]`.

sdim — Standard deviation of imaginary part

3-D array | []

Estimated standard deviation of the imaginary part of the response at each frequency point, returned as a 3-D array. `sdim` has the same dimensions as `im`.

If `sys` is not an identified LTI model, `sdim` is `[]`.

Tips

- When you need additional plot customization options, use `nyquistplot` instead.
- Two zoom options that apply specifically to Nyquist plots are available from the right-click menu :
 - **Full View** — Clips unbounded branches of the Nyquist plot, but still includes the critical point $(-1, 0)$.
 - **Zoom on (-1,0)** — Zooms around the critical point $(-1, 0)$. To access critical-point zoom programmatically, use the `zoomcp` command. For more information, see `nyquistplot`.
- To activate data markers that display the real and imaginary values at a given frequency, click anywhere on the curve. The following figure shows a `nyquist` plot with a data marker.

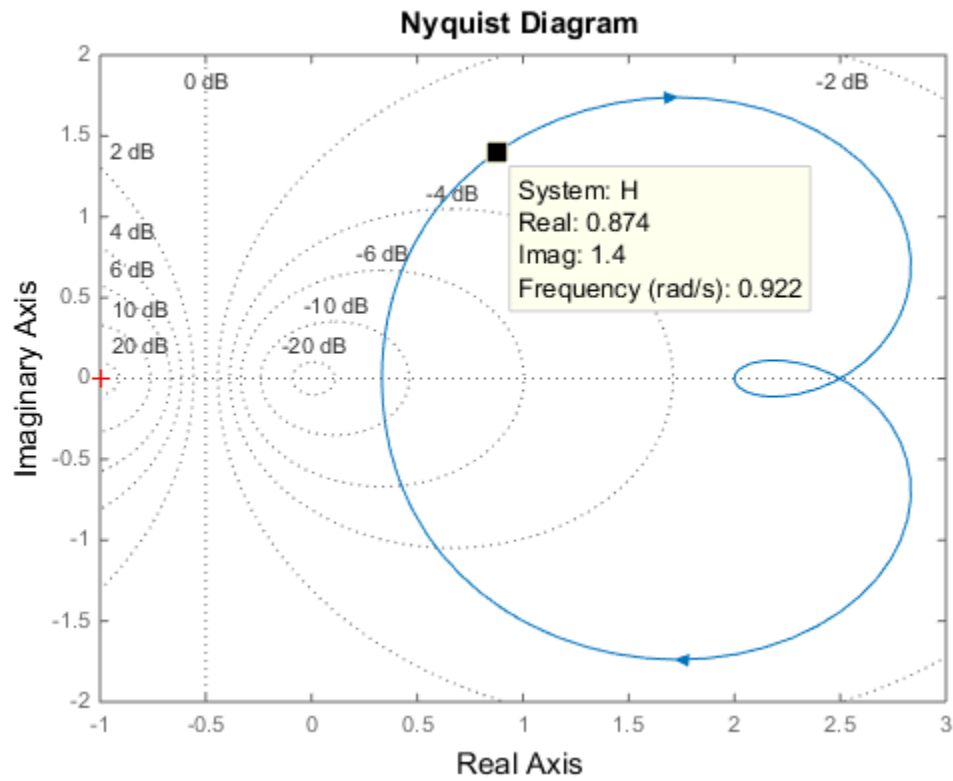

Version History

Introduced before R2006a

See Also

`nichols` | `sigma` | `bode` | `nyquistplot`

Topics

“Frequency-Domain Responses”

“Dynamic System Models”

nyquistoptions

Create list of Nyquist plot options

Description

Use the `nyquistoptions` command to create a `NyquistPlotOptions` object to customize your Nyquist plot appearance. You can also use the command to override the plot preference settings in the MATLAB session in which you create the Nyquist plots.

Creation

Syntax

```
plotoptions = nyquistoptions  
plotoptions = nyquistoptions('cstprefs')
```

Description

`plotoptions = nyquistoptions` returns a default set of plot options for use with the `nyquistplot` command. You can use these options to customize the Nyquist plot appearance using the command line. This syntax is useful when you want to write a script to generate plots that look the same regardless of the preference settings of the MATLAB session in which you run the script.

`plotoptions = nyquistoptions('cstprefs')` initializes the plot options with the options you selected in the Control System Toolbox and System Identification Toolbox Preferences Editor. For more information about the editor, see “Toolbox Preferences Editor”. This syntax is useful when you want to change a few plot options but otherwise use your default preferences. A script that uses this syntax may generate results that look different when run in a session with different preferences.

Properties

FreqUnits — Frequency units

'rad/s' (default)

Frequency units, specified as one of the following values:

- 'Hz'
- 'rad/second'
- 'rpm'
- 'kHz'
- 'MHz'
- 'GHz'
- 'rad/nanosecond'
- 'rad/microsecond'

- 'rad/millisecond'
- 'rad/minute'
- 'rad/hour'
- 'rad/day'
- 'rad/week'
- 'rad/month'
- 'rad/year'
- 'cycles/nanosecond'
- 'cycles/microsecond'
- 'cycles/millisecond'
- 'cycles/hour'
- 'cycles/day'
- 'cycles/week'
- 'cycles/month'
- 'cycles/year'

MagUnits — Magnitude units

'dB' (default) | 'abs'

Magnitude units, specified as either 'dB' or absolute value 'abs'.

PhaseUnits — Phase units

'deg' (default) | 'rad'

Phase units, specified as either 'deg' or 'rad' to change to degrees or radians, respectively.

ShowFullContour — Toggle display of the response for negative frequencies

'on' (default) | 'off'

Toggle display of the response for negative frequencies, specified as either 'on' or 'off'.

ConfidenceRegionNumberSD — Number of standard deviations to use to plot the confidence region

1 (default) | scalar

Number of standard deviations to use to plot the confidence region, specified as a scalar. This is applicable to identified models only.

ConfidenceRegionDisplaySpacing — Frequency spacing of the confidence ellipses

5 (default) | scalar

Frequency spacing of the confidence ellipses to use to plot the confidence region, specified as a scalar. This is applicable to identified models only. The default value is 5, which means the confidence ellipses are shown at every 5th frequency sample

IOWGrouping — Grouping of input-output pairs

'none' (default) | 'inputs' | 'outputs' | 'all'

Grouping of input-output (I/O) pairs, specified as one of the following:

- 'none' — No input-output grouping.
- 'inputs' — Group only the inputs.
- 'outputs' — Group only the outputs.
- 'all' — Group all the I/O pairs.

InputLabels — Input label style

structure (default)

Input label style, specified as a structure with the following fields:

- **FontSize** — Font size, specified as a scalar value greater than zero in point units. The default font size depends on the specific operating system and locale. One point equals 1/72 inch.
- **FontWeight** — Character thickness, specified as 'Normal' or 'bold'. MATLAB uses the **FontWeight** property to select a font from those available on your system. Not all fonts have a bold weight. Therefore, specifying a bold font weight can still result in the normal font weight.
- **FontAngle** — Character slant, specified as 'Normal' or 'italic'. Not all fonts have both font styles. Therefore, the italic font might look the same as the normal font.
- **Color** — Text color, specified as an RGB triplet. The default color is dark grey with the RGB triplet [0.4,0.4,0.4].
- **Interpreter** — Text interpreter, specified as one of these values:
 - 'tex' — Interpret characters using a subset of TeX markup. This is the default value of **Interpreter**.
 - 'latex' — Interpret characters using LaTeX markup.
 - 'none' — Display literal characters.

OutputLabels — Output label style

structure (default)

Output label style, specified as a structure with the following fields:

- **FontSize** — Font size, specified as a scalar value greater than zero in point units. The default font size depends on the specific operating system and locale. One point equals 1/72 inch.
- **FontWeight** — Character thickness, specified as 'Normal' or 'bold'. MATLAB uses the **FontWeight** property to select a font from those available on your system. Not all fonts have a bold weight. Therefore, specifying a bold font weight can still result in the normal font weight.
- **FontAngle** — Character slant, specified as 'Normal' or 'italic'. Not all fonts have both font styles. Therefore, the italic font might look the same as the normal font.
- **Color** — Text color, specified as an RGB triplet. The default color is dark grey with the RGB triplet [0.4,0.4,0.4].
- **Interpreter** — Text interpreter, specified as one of these values:
 - 'tex' — Interpret characters using a subset of TeX markup. This is the default value of **Interpreter**.
 - 'latex' — Interpret characters using LaTeX markup.
 - 'none' — Display literal characters.

InputVisible — Toggle display of inputs

{ 'on' } (default) | { 'off' } | cell array

Toggle display of inputs, specified as either `{'on'}`, `{'off'}` or a cell array with multiple elements .

OutputVisible — Toggle display of outputs

`{'on'}` (default) | `{'off'}` | cell array

Toggle display of outputs, specified as either `{'on'}`, `{'off'}` or a cell array with multiple elements.

Title — Title text and style

structure (default)

Title text and style, specified as a structure with the following fields:

- **String** — Label text, specified as a character vector. By default, the plot is titled 'Nyquist Diagram'.
- **FontSize** — Font size, specified as a scalar value greater than zero in point units. The default font size depends on the specific operating system and locale. One point equals 1/72 inch.
- **FontWeight** — Character thickness, specified as 'Normal' or 'bold'. MATLAB uses the **FontWeight** property to select a font from those available on your system. Not all fonts have a bold weight. Therefore, specifying a bold font weight can still result in the normal font weight.
- **FontAngle** — Character slant, specified as 'Normal' or 'italic'. Not all fonts have both font styles. Therefore, the italic font might look the same as the normal font.
- **Color** — Text color, specified as an RGB triplet. The default color is black specified by the RGB triplet `[0,0,0]`.
- **Interpreter** — Text interpreter, specified as one of these values:
 - `'tex'` — Interpret characters using a subset of TeX markup. This is the default value of **Interpreter**.
 - `'latex'` — Interpret characters using LaTeX markup.
 - `'none'` — Display literal characters.

XLabel — X-axis label text and style

structure (default)

X-axis label text and style, specified as a structure with the following fields:

- **String** — Label text, specified as a character vector. By default, the axis is titled 'Real Axis'.
- **FontSize** — Font size, specified as a scalar value greater than zero in point units. The default font size depends on the specific operating system and locale. One point equals 1/72 inch.
- **FontWeight** — Character thickness, specified as 'Normal' or 'bold'. MATLAB uses the **FontWeight** property to select a font from those available on your system. Not all fonts have a bold weight. Therefore, specifying a bold font weight can still result in the normal font weight.
- **FontAngle** — Character slant, specified as 'Normal' or 'italic'. Not all fonts have both font styles. Therefore, the italic font might look the same as the normal font.
- **Color** — Text color, specified as an RGB triplet. The default color is black specified by the RGB triplet `[0,0,0]`.
- **Interpreter** — Text interpreter, specified as one of these values:
 - `'tex'` — Interpret characters using a subset of TeX markup. This is the default value of **Interpreter**.

- 'latex' — Interpret characters using LaTeX markup.
- 'none' — Display literal characters.

YLabel — Y-axis label text and style

structure (default)

Y-axis label text and style, specified as a structure with the following fields:

- **String** — Label text, specified as a cell array of character vectors. By default, the axis is titled 'Imaginary Axis'.
- **FontSize** — Font size, specified as a scalar value greater than zero in point units. The default font size depends on the specific operating system and locale. One point equals 1/72 inch.
- **FontWeight** — Character thickness, specified as 'Normal' or 'bold'. MATLAB uses the **FontWeight** property to select a font from those available on your system. Not all fonts have a bold weight. Therefore, specifying a bold font weight can still result in the normal font weight.
- **FontAngle** — Character slant, specified as 'Normal' or 'italic'. Not all fonts have both font styles. Therefore, the italic font might look the same as the normal font.
- **Color** — Text color, specified as an RGB triplet. The default color is black specified by the RGB triplet [0,0,0].
- **Interpreter** — Text interpreter, specified as one of these values:
 - 'tex' — Interpret characters using a subset of TeX markup. This is the default value of **Interpreter**.
 - 'latex' — Interpret characters using LaTeX markup.
 - 'none' — Display literal characters.

TickLabel — Tick label style

structure (default)

Tick label style, specified as a structure with the following fields:

- **FontSize** — Font size, specified as a scalar value greater than zero in point units. The default font size depends on the specific operating system and locale. One point equals 1/72 inch.
- **FontWeight** — Character thickness, specified as 'Normal' or 'bold'. MATLAB uses the **FontWeight** property to select a font from those available on your system. Not all fonts have a bold weight. Therefore, specifying a bold font weight can still result in the normal font weight.
- **FontAngle** — Character slant, specified as 'Normal' or 'italic'. Not all fonts have both font styles. Therefore, the italic font might look the same as the normal font.
- **Color** — Text color, specified as an RGB triplet. The default color is black specified by the RGB triplet [0,0,0].

Grid — Toggle grid display

'off' (default) | 'on'

Toggle grid display on the plot, specified as either 'off' or 'on'.

GridColor — Color of the grid lines

[0.15,0.15,0.15] (default) | RGB triplet

Color of the grid lines, specified as an RGB triplet. The default color is light grey specified by the RGB triplet [0.15,0.15,0.15].

XLimMode — X-axis limit selection mode`'auto'` (default) | `'manual'` | cell array

Selection mode for the x-axis limits, specified as one of these values:

- `'auto'` — Enable automatic limit selection, which is based on the total span of the plotted data.
- `'manual'` — Manually specify the axis limits. To specify the axis limits, set the `XLim` property.

YLimMode — Y-axis limit selection mode`'auto'` (default) | `'manual'` | cell array

Selection mode for the y-axis limits, specified as one of these values:

- `'auto'` — Enable automatic limit selection, which is based on the total span of the plotted data.
- `'manual'` — Manually specify the axis limits. To specify the axis limits, set the `YLim` property.

XLim — X-axis limits`'{[1,10]}'` (default) | cell array of two-element vector of the form `[min,max]` | cell array

X-axis limits, specified as a cell array of two-element vector of the form `[min,max]`.

YLim — Y-axis limits`'{[1,10]}'` (default) | cell array of two-element vector of the form `[min,max]` | cell array

Y-axis limits, specified as a cell array of two-element vector of the form `[min,max]`.

Object Functions

`nyquistplot` Nyquist plot with additional plot customization options

Examples**Customize Nyquist Plot using Plot Handle**

For this example, use the plot handle to change the phase units to radians and to turn the grid on.

Generate a random state-space model with 5 states and create the Nyquist diagram with plot handle `h`.

```
rng("default")
sys = rss(5);
h = nyquistplot(sys);
```

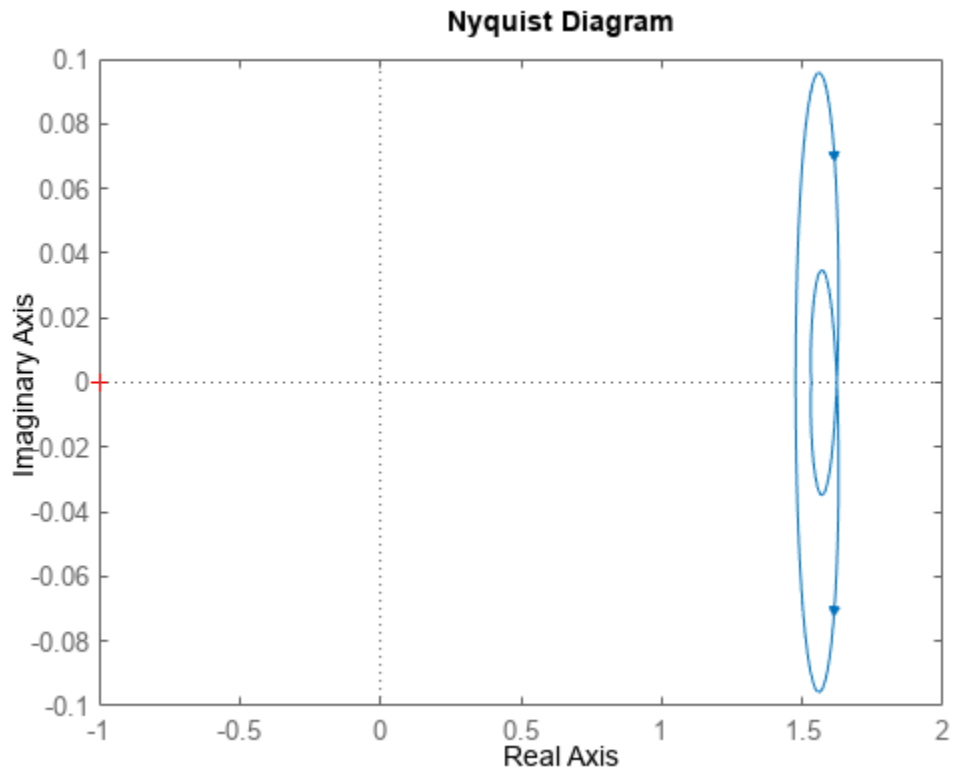

Change the phase units to radians and turn on the grid. To do so, edit properties of the plot handle, `h` using `setoptions`.

```
setoptions(h, 'PhaseUnits', 'rad', 'Grid', 'on');
```

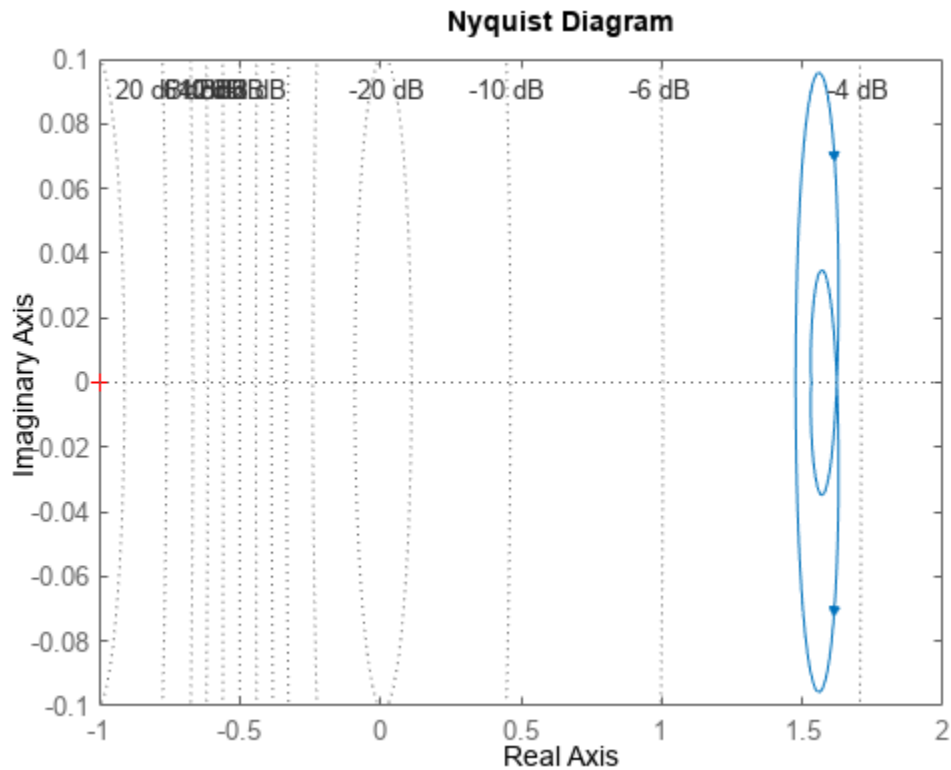

The Nyquist plot automatically updates when you call `setoptions`.

Alternatively, you can also use the `nyquistoptions` command to specify the required plot options. First, create an options set based on the toolbox preferences.

```
plotoptions = nyquistoptions('cstprefs');
```

Change properties of the options set by setting the phase units to radians and enabling the grid.

```
plotoptions.PhaseUnits = 'rad';
plotoptions.Grid = 'on';
nyquistplot(sys,plotoptions);
```

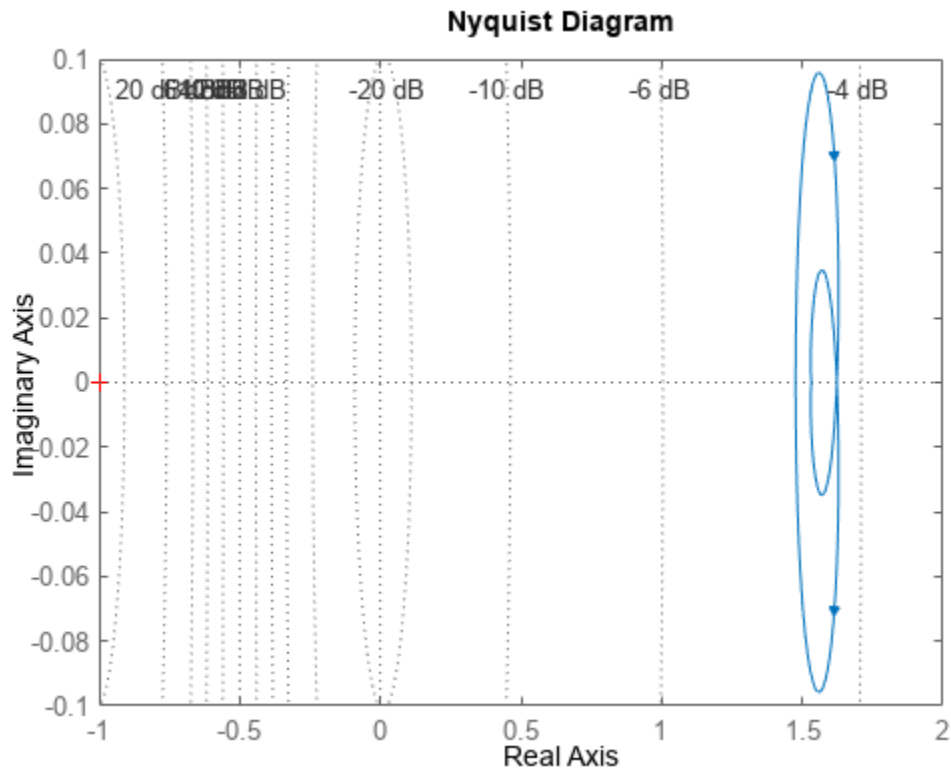

You can use the same option set to create multiple Nyquist plots with the same customization. Depending on your own toolbox preferences, the plot you obtain might look different from this plot. Only the properties that you set explicitly, in this example `PhaseUnits` and `Grid`, override the toolbox preferences.

Nyquist Plot of Identified Models with Confidence Regions at Selected Points

Compare the frequency responses of identified state-space models of order 2 and 6 along with their 1-std confidence regions rendered at every 50th frequency sample.

Load the identified model data and estimate the state-space models using `n4sid`. Then, plot the Nyquist diagram.

```
load iddata1
sys1 = n4sid(z1,2);
sys2 = n4sid(z1,6);
w = linspace(10,10*pi,256);
h = nyquistplot(sys1,sys2,w);
```

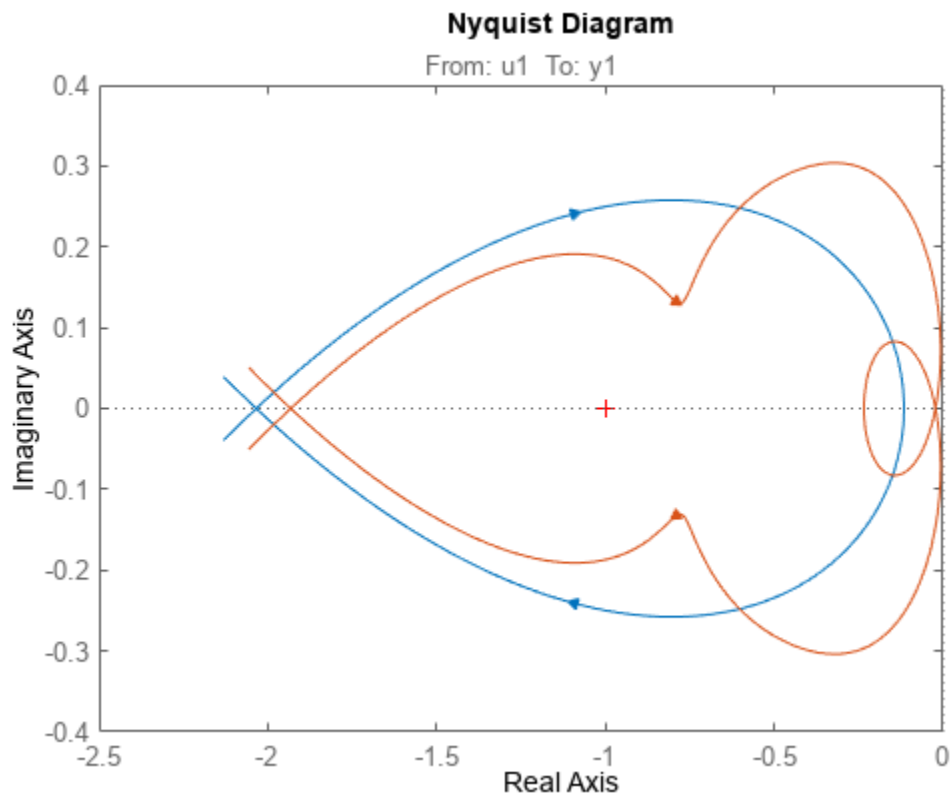

Both models produce about 76% fit to data. However, `sys2` shows higher uncertainty in its frequency response, especially close to Nyquist frequency as shown by the plot. To see this, show the confidence region at a subset of the points at which the Nyquist response is displayed.

```
setoptions(h, 'ConfidenceRegionDisplaySpacing', 50, ...  
           'ShowFullContour', 'off');
```

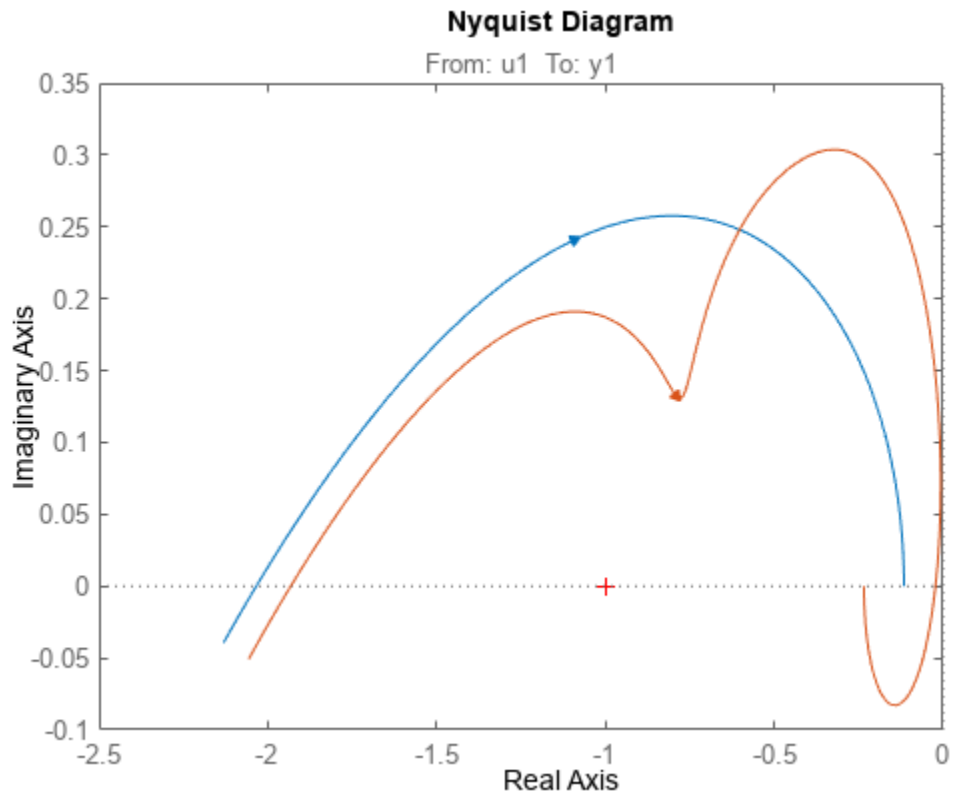

To turn on the confidence region display, right-click the plot and select **Characteristics > Confidence Region**.

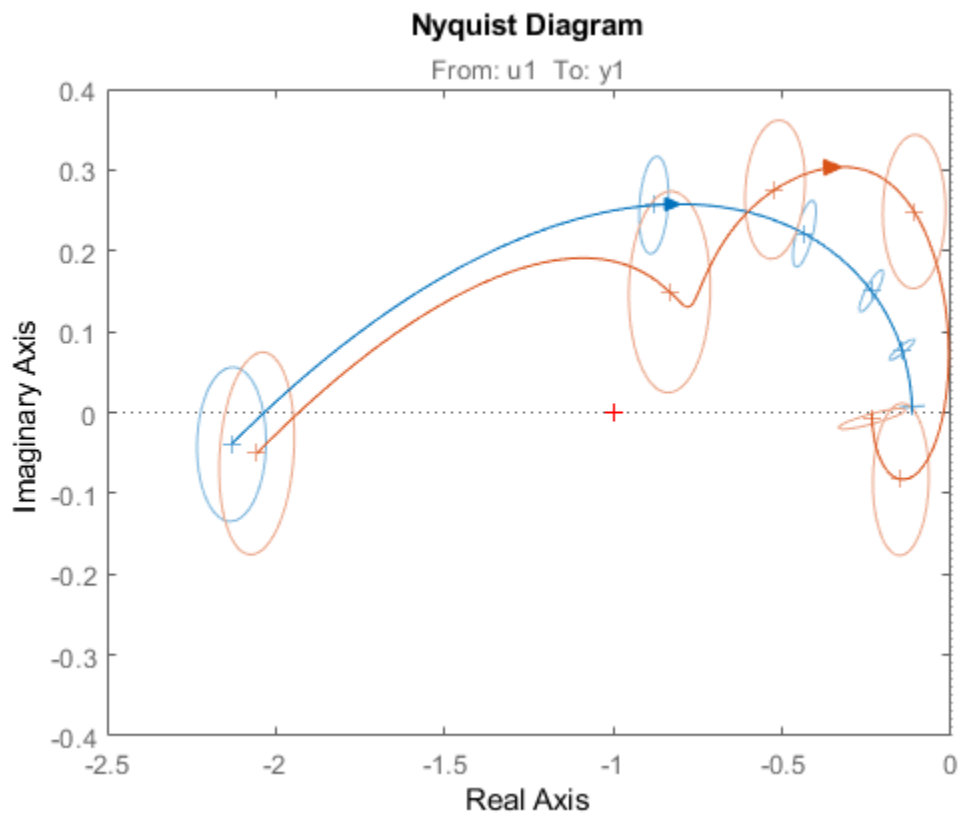

Nyquist Plot with Specific Customization

For this example, consider a MIMO state-space model with 3 inputs, 3 outputs and 3 states. Create a Nyquist plot, display only the partial contour and turn the grid on.

Create the MIMO state-space model `sys_mimo`.

```
J = [8 -3 -3; -3 8 -3; -3 -3 8];
F = 0.2*eye(3);
A = -J\F;
B = inv(J);
C = eye(3);
D = 0;
sys_mimo = ss(A,B,C,D);
size(sys_mimo)
```

State-space model with 3 outputs, 3 inputs, and 3 states.

Create a Nyquist plot with plot handle `h` and use `getoptions` for a list of the options available.

```
h = nyquistplot(sys_mimo);
```

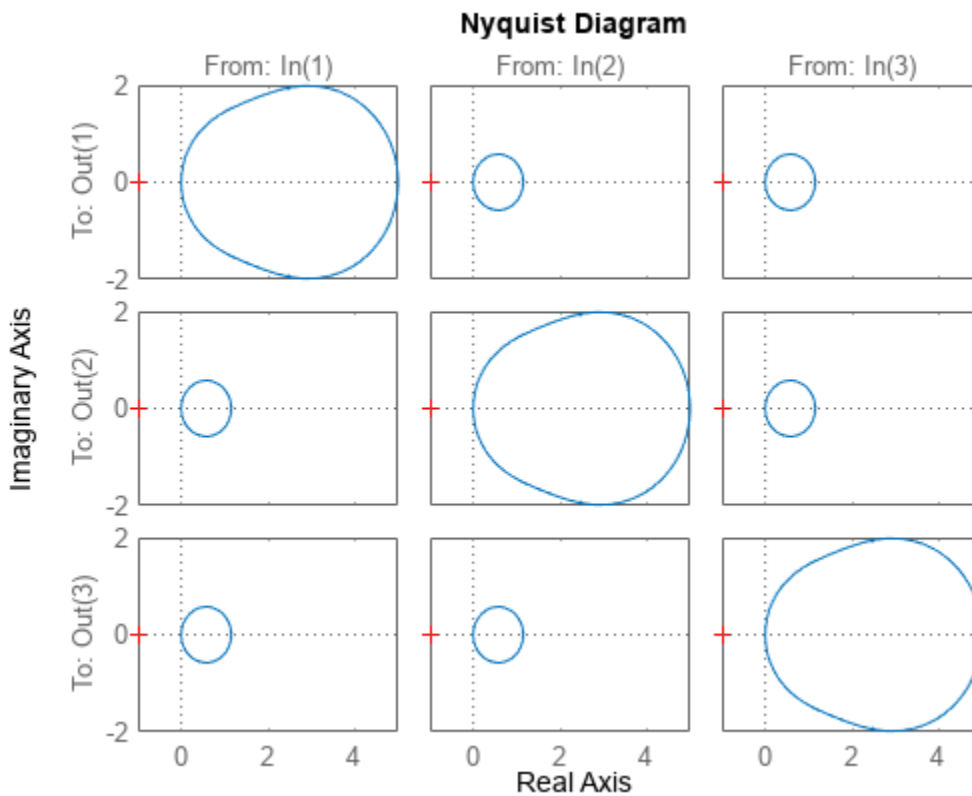

```
p = getoptions(h)
```

```
p =
```

```

    FreqUnits: 'rad/s'
    MagUnits: 'dB'
    PhaseUnits: 'deg'
    ShowFullContour: 'on'
    ConfidenceRegionNumberSD: 1
    ConfidenceRegionDisplaySpacing: 5
    IOGrouping: 'none'
    InputLabels: [1x1 struct]
    OutputLabels: [1x1 struct]
    InputVisible: {3x1 cell}
    OutputVisible: {3x1 cell}
    Title: [1x1 struct]
    XLabel: [1x1 struct]
    YLabel: [1x1 struct]
    TickLabel: [1x1 struct]
    Grid: 'off'
    GridColor: [0.1500 0.1500 0.1500]
    XLim: {3x1 cell}
    YLim: {3x1 cell}
    XLimMode: {3x1 cell}
    YLimMode: {3x1 cell}

```

Use `setoptions` to update the plot with the requires customization.

```
setoptions(h, 'ShowFullContour', 'off', 'Grid', 'on');
```

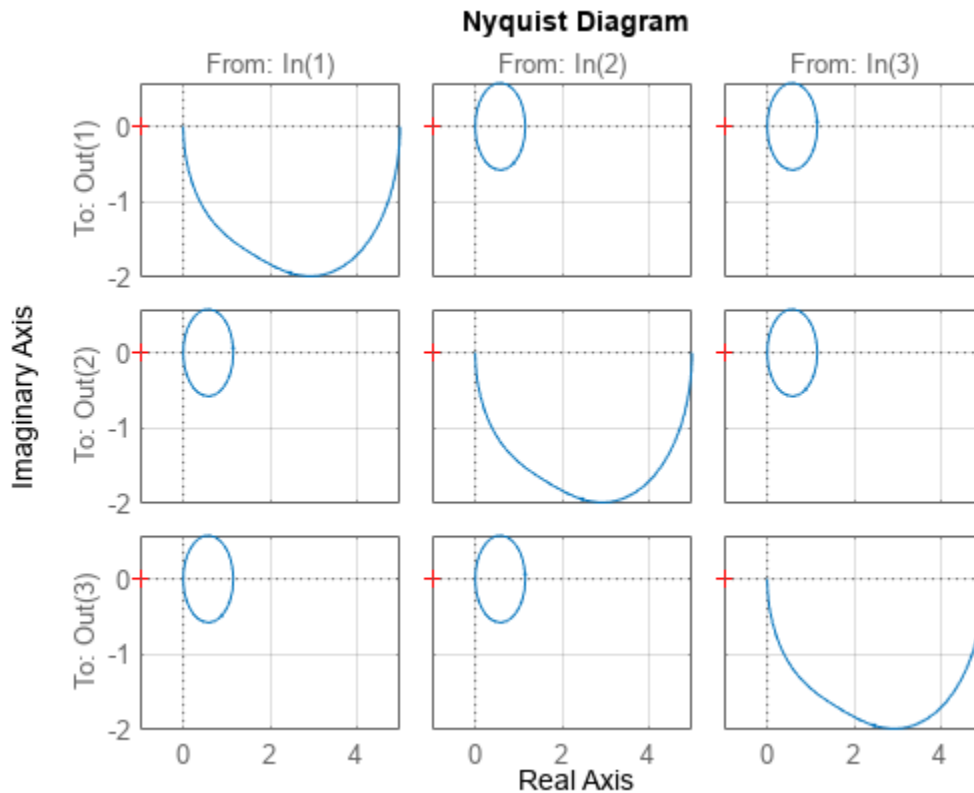

The Nyquist plot automatically updates when you call `setoptions`. For MIMO models, `nyquistplot` produces an array of Nyquist diagrams, each plot displaying the frequency response of one I/O pair.

Version History

Introduced in R2011a

See Also

`nyquist` | `nyquistplot` | `getoptions` | `setoptions`

Topics

“Toolbox Preferences Editor”

nyquistplot

Nyquist plot with additional plot customization options

Syntax

```
h = nyquistplot(sys)
h = nyquistplot(sys1,sys2,...,sysN)
h = nyquistplot(sys1,LineStyle1,...,sysN,LineStyleN)
h = nyquistplot( ____,w)
h = nyquistplot(AX, ____)
h = nyquistplot( ____,plotoptions)
```

Description

`nyquistplot` lets you plot the Nyquist diagram of a dynamic system model with a broader range of plot customization options than `nyquist`. You can use `nyquistplot` to obtain the plot handle and use it to customize the plot, such as modify the axes labels, limits and units. You can also use `nyquistplot` to draw a Nyquist diagram on an existing set of axes represented by an axes handle. To customize an existing Nyquist plot using the plot handle:

- 1 Obtain the plot handle
- 2 Use `getoptions` to obtain the option set
- 3 Update the plot using `setoptions` to modify the required options

For more information, see “Customizing Response Plots from the Command Line”. To create Nyquist plots with default options or to extract the standard deviation, real and imaginary parts of the frequency response data, use `nyquist`.

`h = nyquistplot(sys)` plots the Nyquist plot of the dynamic system model `sys` and returns the plot handle `h` to the plot. You can use this handle `h` to customize the plot with the `getoptions` and `setoptions` commands. If `sys` is a multi-input, multi-output (MIMO) model, then `nyquistplot` produces a grid of Nyquist plots, each plot displaying the frequency response of one I/O pair.

`h = nyquistplot(sys1,sys2,...,sysN)` plots the Nyquist plot of multiple dynamic systems `sys1,sys2,...,sysN` on the same plot. All systems must have the same number of inputs and outputs to use this syntax.

`h = nyquistplot(sys1,LineStyle1,...,sysN,LineStyleN)` sets the line style, marker type, and color for the Nyquist plot of each system. All systems must have the same number of inputs and outputs to use this syntax.

`h = nyquistplot(____,w)` plots Nyquist diagram for frequencies specified by the frequencies in `w`.

- If `w` is a cell array of the form `{wmin,wmax}`, then `nyquistplot` plots the Nyquist diagram at frequencies ranging between `wmin` and `wmax`.
- If `w` is a vector of frequencies, then `nyquistplot` plots the Nyquist diagram at each specified frequency.

You can use `w` with any of the input-argument combinations in previous syntaxes.

See `logspace` to generate logarithmically spaced frequency vectors.

`h = nyquistplot(AX, ___)` plots the Nyquist plot on the Axes object in the current figure with the handle `AX`.

`h = nyquistplot(___, plotoptions)` plots the Nyquist plot with the options set specified in `plotoptions`. You can use these options to customize the Nyquist plot appearance using the command line. Settings you specify in `plotoptions` overrides the preference settings in the MATLAB session in which you run `nyquistplot`. Therefore, this syntax is useful when you want to write a script to generate multiple plots that look the same regardless of the local preferences.

Examples

Customize Nyquist Plot using Plot Handle

For this example, use the plot handle to change the phase units to radians and to turn the grid on.

Generate a random state-space model with 5 states and create the Nyquist diagram with plot handle `h`.

```
rng("default")  
sys = rss(5);  
h = nyquistplot(sys);
```

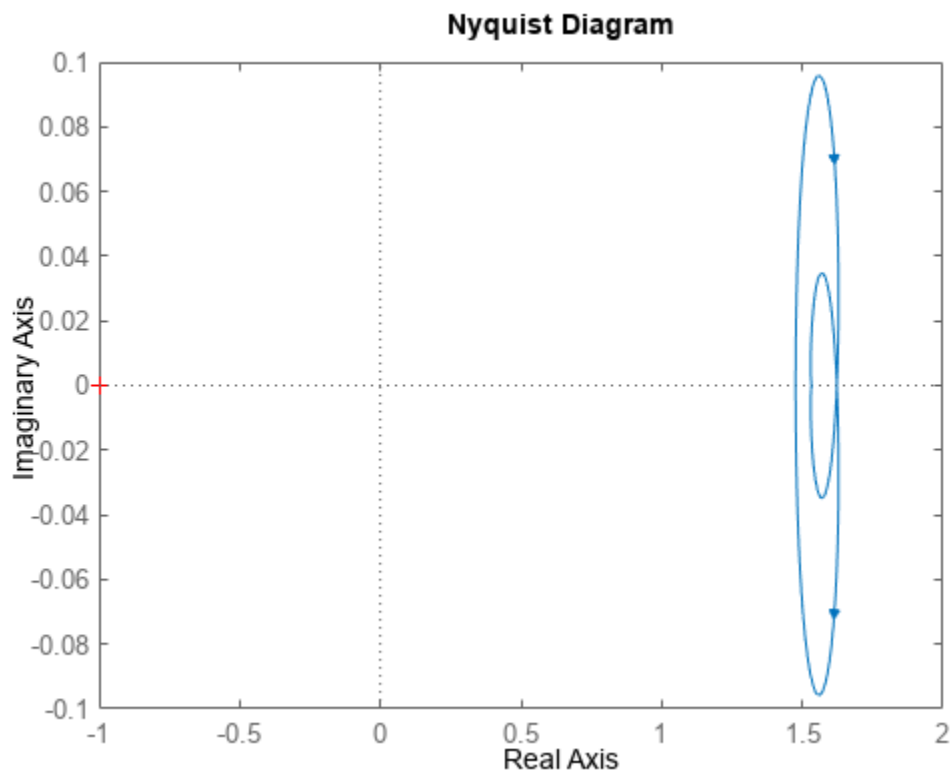

Change the phase units to radians and turn on the grid. To do so, edit properties of the plot handle, `h` using `setoptions`.

```
setoptions(h, 'PhaseUnits', 'rad', 'Grid', 'on');
```

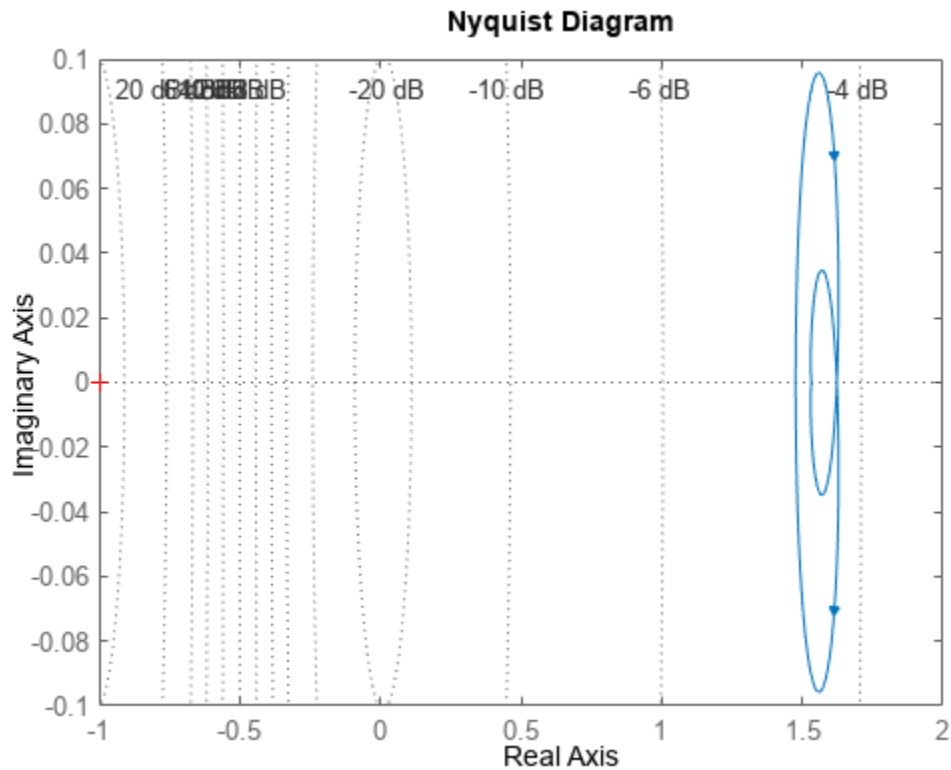

The Nyquist plot automatically updates when you call `setoptions`.

Alternatively, you can also use the `nyquistoptions` command to specify the required plot options. First, create an options set based on the toolbox preferences.

```
plotoptions = nyquistoptions('cstprefs');
```

Change properties of the options set by setting the phase units to radians and enabling the grid.

```
plotoptions.PhaseUnits = 'rad';
plotoptions.Grid = 'on';
nyquistplot(sys, plotoptions);
```

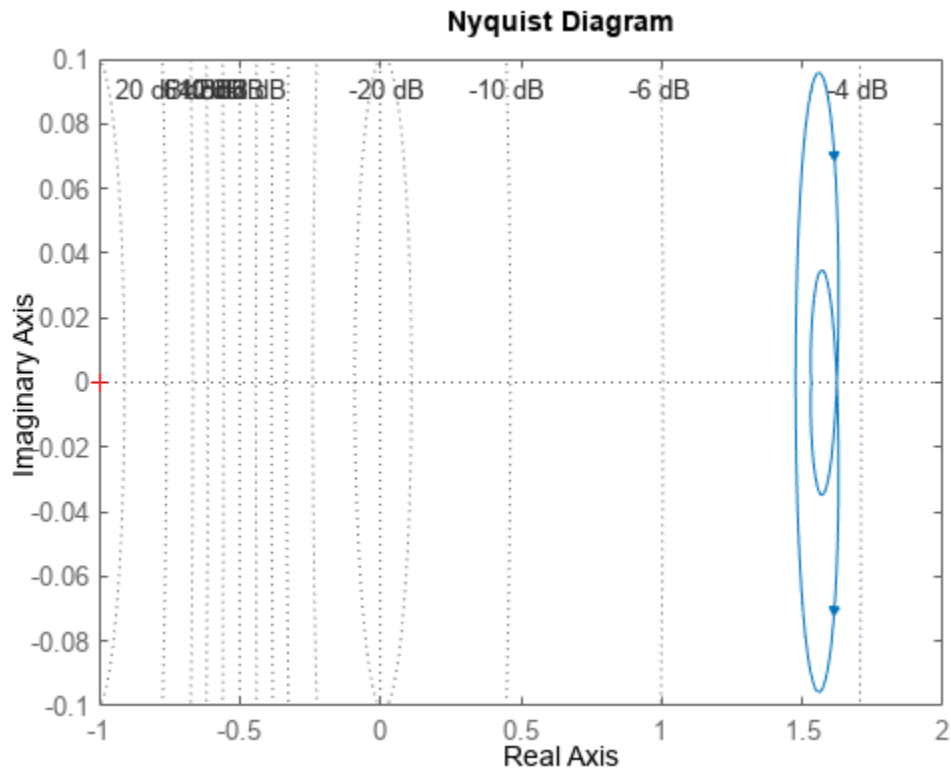

You can use the same option set to create multiple Nyquist plots with the same customization. Depending on your own toolbox preferences, the plot you obtain might look different from this plot. Only the properties that you set explicitly, in this example `PhaseUnits` and `Grid`, override the toolbox preferences.

Customize Nyquist Plot Title

Create a Nyquist plot of a dynamic system model and store a handle to the plot.

```
sys = tf(100,[1,2,1]);
h = nyquistplot(sys);
```

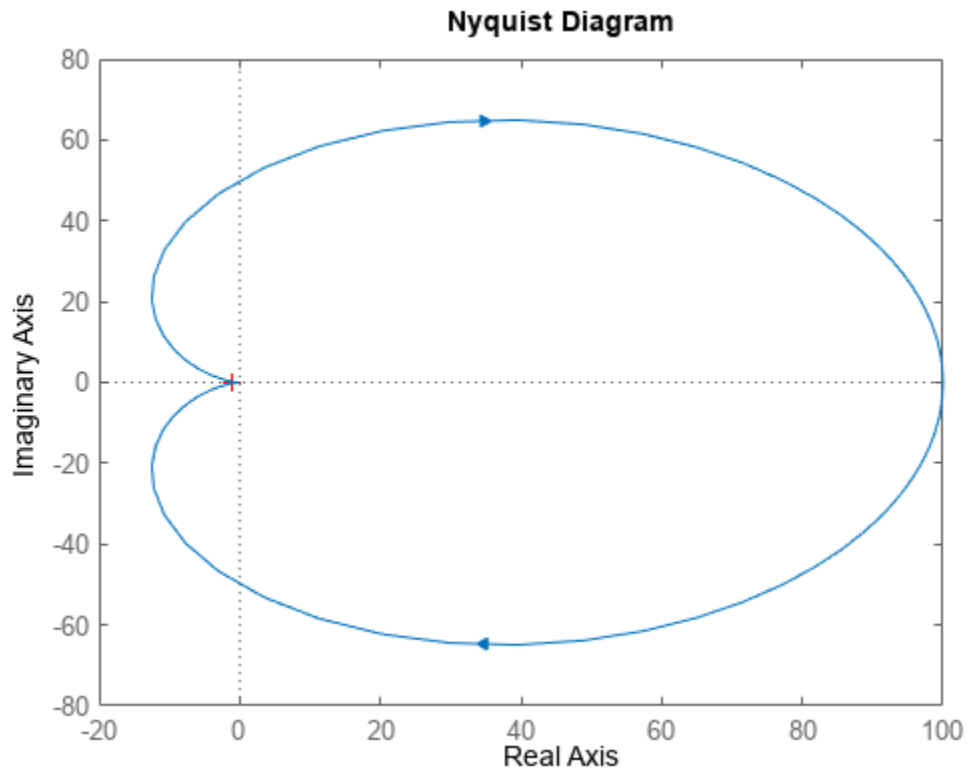

Change the plot title to read "Nyquist Plot of sys." To do so, use `getoptions` to extract the existing plot options from the plot handle `h`.

```
opt = getoptions(h)
```

```
opt =
```

```

        FreqUnits: 'rad/s'
        MagUnits:  'dB'
        PhaseUnits: 'deg'
        ShowFullContour: 'on'
        ConfidenceRegionNumberSD: 1
        ConfidenceRegionDisplaySpacing: 5
        IOGrouping: 'none'
        InputLabels: [1x1 struct]
        OutputLabels: [1x1 struct]
        InputVisible: {'on'}
        OutputVisible: {'on'}
        Title: [1x1 struct]
        XLabel: [1x1 struct]
        YLabel: [1x1 struct]
        TickLabel: [1x1 struct]
        Grid: 'off'
        GridColor: [0.1500 0.1500 0.1500]
        XLim: {[-20 100]}
        YLim: {[-80 80]}
        XLimMode: {'auto'}
        YLimMode: {'auto'}

```



The `Title` option is a structure with several fields.

`opt.Title`

```
ans = struct with fields:
    String: 'Nyquist Diagram'
    FontSize: 11
    FontWeight: 'bold'
    FontAngle: 'normal'
    Color: [0 0 0]
    Interpreter: 'tex'
```

Change the `String` field of the `Title` structure, and use `setoptions` to apply the change to the plot.

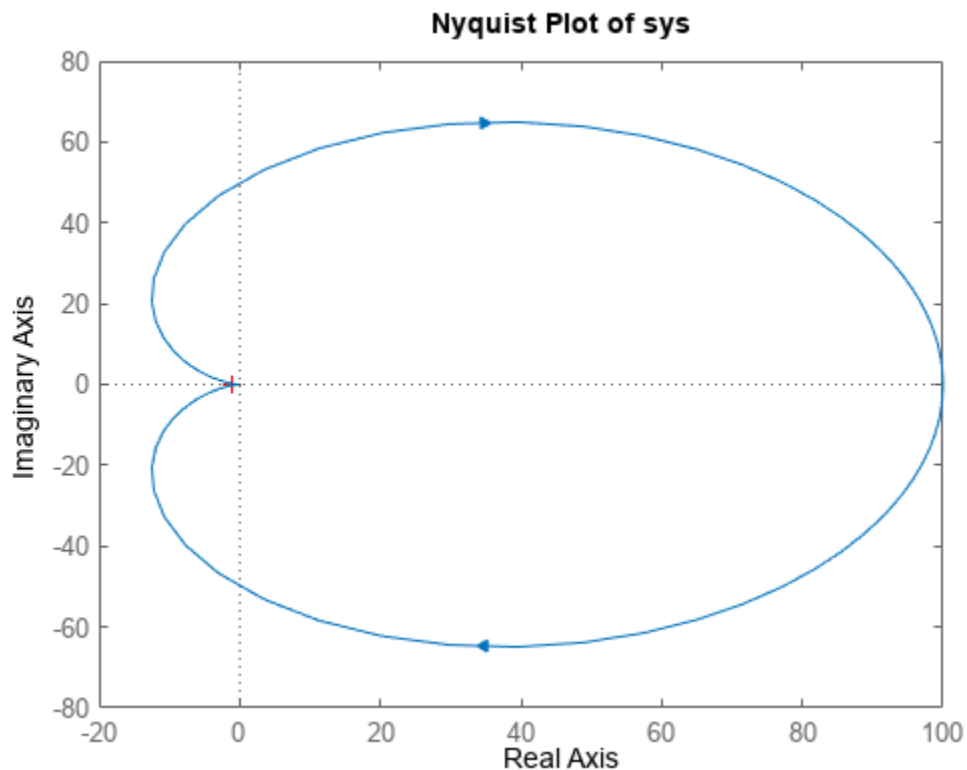
```
opt.Title.String = 'Nyquist Plot of sys';
setoptions(h,opt)
```



Zoom on Critical Point

Plot the Nyquist frequency response of a dynamic system. Assign a variable name to the plot handle so that you can access it for further manipulation.

```
sys = tf(100,[1,2,1]);
h = nyquistplot(sys);
```

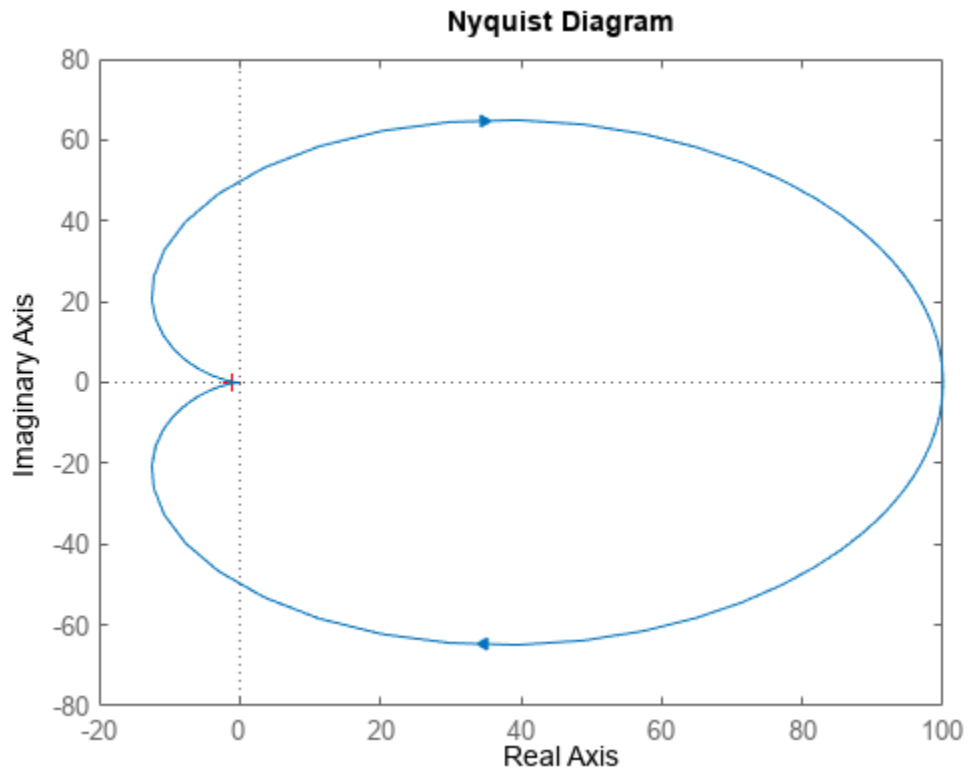

Zoom in on the critical point, $(-1,0)$. You can do so interactively by right-clicking on the plot and selecting **Zoom on $(-1,0)$** . Alternatively, use the `zoomcp` command on the plot handle `h`.

```
zoomcp(h)
```

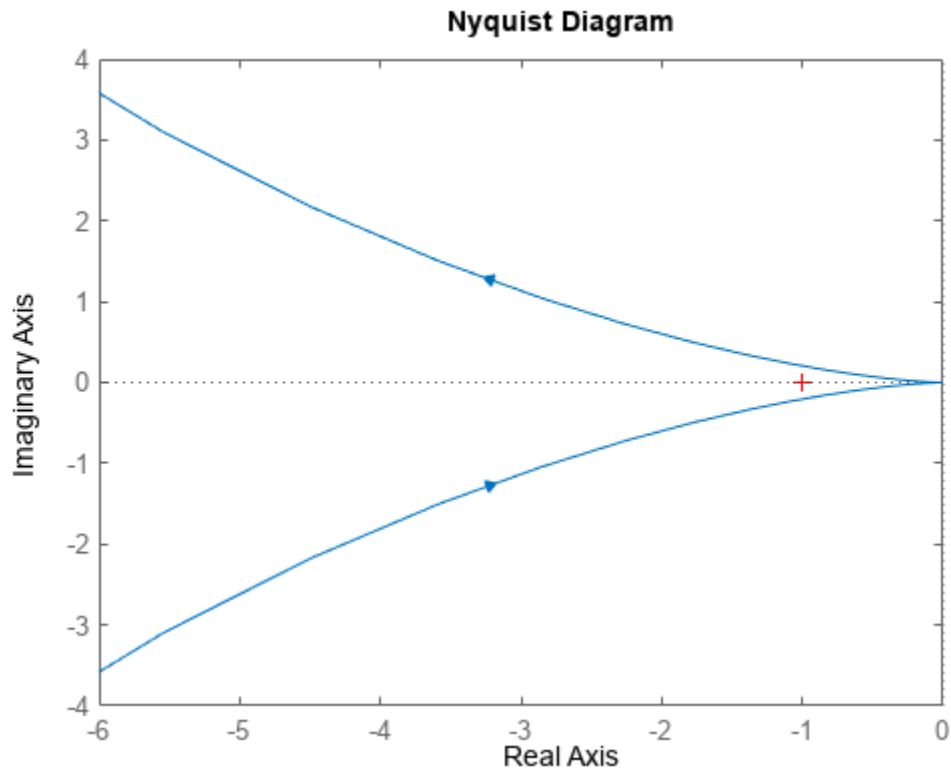

Nyquist Plot of Identified Models with Confidence Regions at Selected Points

Compare the frequency responses of identified state-space models of order 2 and 6 along with their 1-std confidence regions rendered at every 50th frequency sample.

Load the identified model data and estimate the state-space models using `n4sid`. Then, plot the Nyquist diagram.

```
load iddata1
sys1 = n4sid(z1,2);
sys2 = n4sid(z1,6);
w = linspace(10,10*pi,256);
h = nyquistplot(sys1,sys2,w);
```

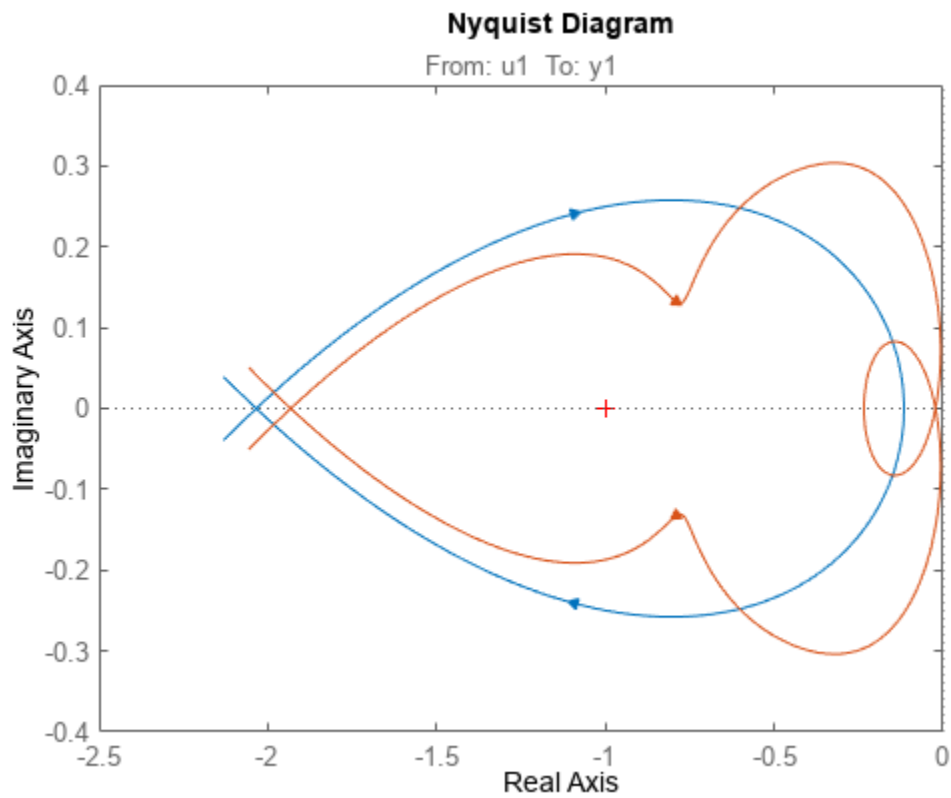

Both models produce about 76% fit to data. However, `sys2` shows higher uncertainty in its frequency response, especially close to Nyquist frequency as shown by the plot. To see this, show the confidence region at a subset of the points at which the Nyquist response is displayed.

```
setoptions(h, 'ConfidenceRegionDisplaySpacing', 50, ...  
           'ShowFullContour', 'off');
```

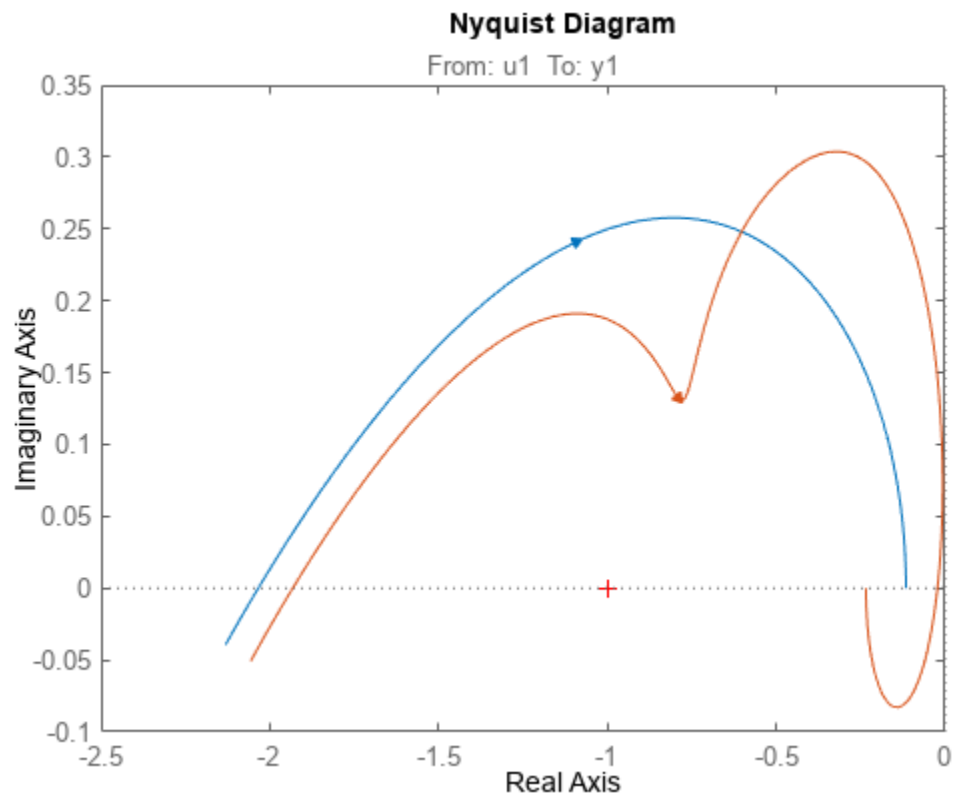

To turn on the confidence region display, right-click the plot and select **Characteristics > Confidence Region**.

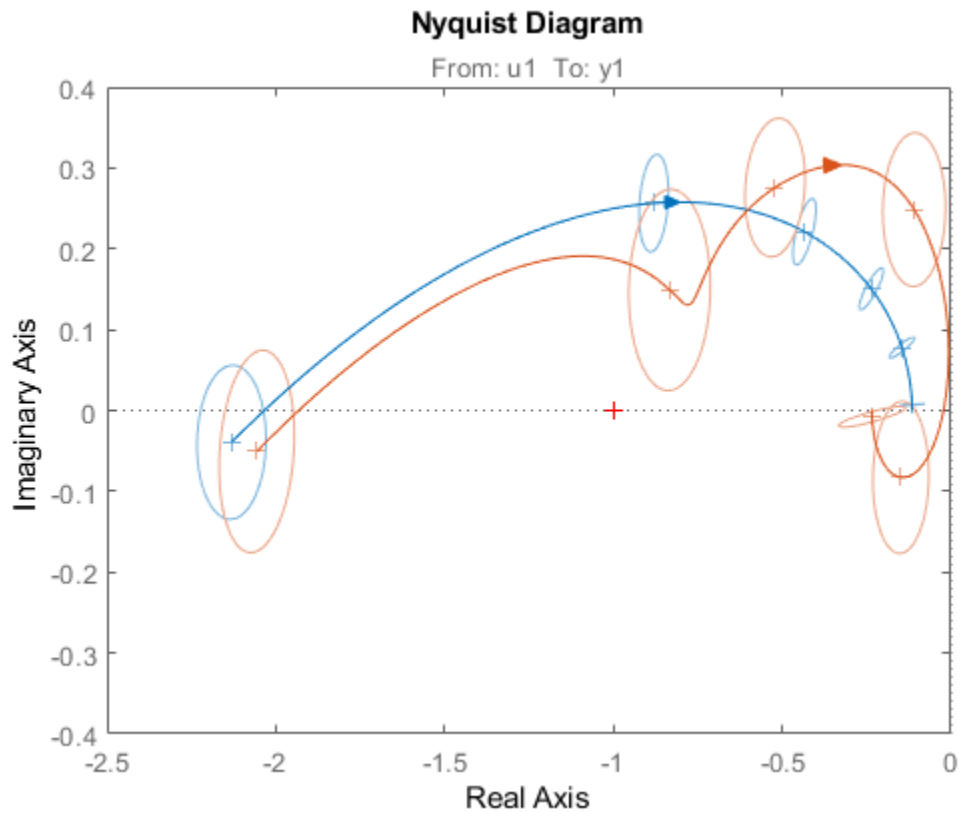

Nyquist Plot with Specific Customization

For this example, consider a MIMO state-space model with 3 inputs, 3 outputs and 3 states. Create a Nyquist plot, display only the partial contour and turn the grid on.

Create the MIMO state-space model `sys_mimo`.

```
J = [8 -3 -3; -3 8 -3; -3 -3 8];
F = 0.2*eye(3);
A = -J\F;
B = inv(J);
C = eye(3);
D = 0;
sys_mimo = ss(A,B,C,D);
size(sys_mimo)
```

State-space model with 3 outputs, 3 inputs, and 3 states.

Create a Nyquist plot with plot handle `h` and use `getoptions` for a list of the options available.

```
h = nyquistplot(sys_mimo);
```

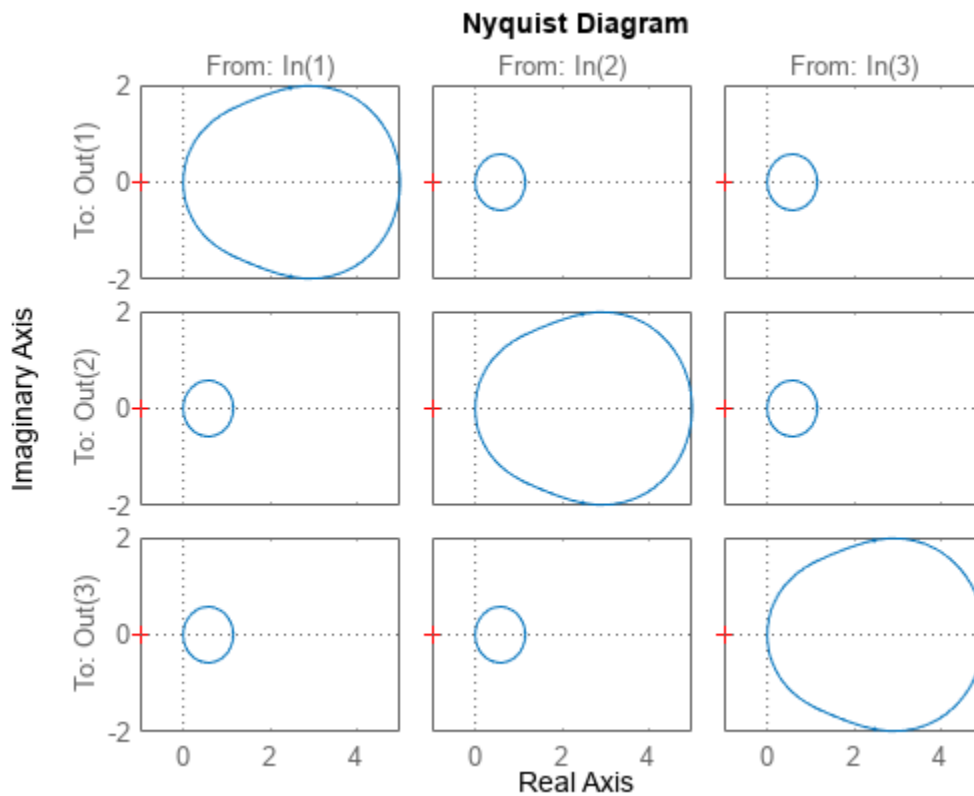

```
p = getoptions(h)
```

```
p =
```

```

    FreqUnits: 'rad/s'
    MagUnits: 'dB'
    PhaseUnits: 'deg'
    ShowFullContour: 'on'
    ConfidenceRegionNumberSD: 1
    ConfidenceRegionDisplaySpacing: 5
    IOGrouping: 'none'
    InputLabels: [1x1 struct]
    OutputLabels: [1x1 struct]
    InputVisible: {3x1 cell}
    OutputVisible: {3x1 cell}
    Title: [1x1 struct]
    XLabel: [1x1 struct]
    YLabel: [1x1 struct]
    TickLabel: [1x1 struct]
    Grid: 'off'
    GridColor: [0.1500 0.1500 0.1500]
    XLim: {3x1 cell}
    YLim: {3x1 cell}
    XLimMode: {3x1 cell}
    YLimMode: {3x1 cell}

```

Use `setoptions` to update the plot with the requires customization.

```
setoptions(h, 'ShowFullContour', 'off', 'Grid', 'on');
```

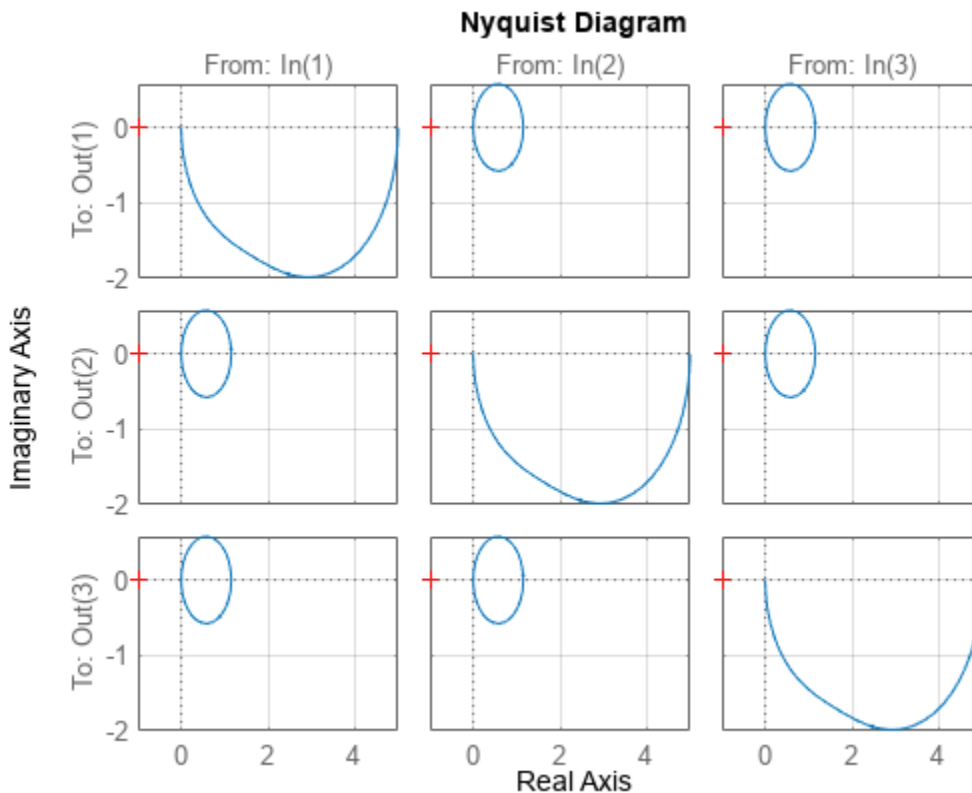

The Nyquist plot automatically updates when you call `setoptions`. For MIMO models, `nyquistplot` produces an array of Nyquist diagrams, each plot displaying the frequency response of one I/O pair.

Input Arguments

sys – Dynamic system

dynamic system model | model array

Dynamic system, specified as a SISO or MIMO dynamic system model or array of dynamic system models. Dynamic systems that you can use include:

- Continuous-time or discrete-time numeric LTI models, such as `tf`, `zpk`, or `ss` models.
- Sparse state-space models, such as `sparss` or `mechss` models. Frequency grid `w` must be specified for sparse models.
- Generalized or uncertain LTI models such as `genss` or `uss` models. (Using uncertain models requires Robust Control Toolbox software.)
 - For tunable control design blocks, the function evaluates the model at its current value to plot the frequency response data.
 - For uncertain control design blocks, the function plots the nominal value and random samples of the model.

- Frequency-response data models such as `frd` models. For such models, the function plots the Nyquist plot at frequencies defined in the model.
- Identified LTI models, such as `idtf`, `idss`, or `idproc` models. (Using identified models requires System Identification Toolbox software.)

If `sys` is an array of models, the function plots the Nyquist responses of all models in the array on the same axes.

LineStyle – Line style, marker, and color

character vector | string

Line style, marker, and color, specified as a character vector or string containing symbols. The symbols can appear in any order. You do not need to specify all three characteristics (line style, marker, and color). For example, if you omit the line style and specify the marker, then the plot shows only the marker and no line.

Example: `'--or'` is a red dashed line with circle markers

Line Style	Description
-	Solid line
--	Dashed line
:	Dotted line
-.	Dash-dot line

Marker	Description
'o'	Circle
'+'	Plus sign
'*'	Asterisk
'.'	Point
'x'	Cross
'_'	Horizontal line
' '	Vertical line
's'	Square
'd'	Diamond
'^'	Upward-pointing triangle
'v'	Downward-pointing triangle
'>'	Right-pointing triangle
'<'	Left-pointing triangle
'p'	Pentagram
'h'	Hexagram

Color	Description
y	yellow
m	magenta

Color	Description
c	cyan
r	red
g	green
b	blue
w	white
k	black

AX — Target axes

Axes object | UIAxes object

Target axes, specified as an `Axes` or `UIAxes` object. If you do not specify the axes and if the current axes are Cartesian axes, then `nyquistplot` plots on the current axes.

plotoptions — Nyquist plot options set

NyquistPlotOptions object

Nyquist plot options set, specified as a `NyquistPlotOptions` object. You can use this option set to customize the Nyquist plot appearance. Use `nyquistoptions` to create the option set. Settings you specify in `plotoptions` overrides the preference settings in the MATLAB session in which you run `nyquistplot`. Therefore, `plotoptions` is useful when you want to write a script to generate multiple plots that look the same regardless of the local preferences.

For the list of available options, see `nyquistoptions`.

w — Frequencies

{wmin,wmax} | vector

Frequencies at which to compute and plot Nyquist response, specified as the cell array {wmin,wmax} or as a vector of frequency values.

- If `w` is a cell array of the form {wmin,wmax}, then the function computes the response at frequencies ranging between `wmin` and `wmax`.
- If `w` is a vector of frequencies, then the function computes the response at each specified frequency. For example, use `logspace` to generate a row vector with logarithmically spaced frequency values.

Specify frequencies in units of `rad/TimeUnit`, where `TimeUnit` is the `TimeUnit` property of the model.

Output Arguments**h — Plot handle**

handle object

Plot handle, returned as a `handle` object. Use the handle `h` to get and set the properties of the Nyquist plot using `getoptions` and `setoptions`. For the list of available options, see the *Properties and Values Reference* section in “Customizing Response Plots from the Command Line”.

Tips

- There are two zoom options available from the right-click menu that apply specifically to Nyquist plots:
 - **Full View** — Clips unbounded branches of the Nyquist plot, but still includes the critical point $(-1, 0)$.
 - **Zoom on $(-1,0)$** — Zooms around the critical point $(-1,0)$. To access critical-point zoom programmatically, use the `zoomcp` command. See “Zoom on Critical Point” on page 2-847.
- To activate data markers that display the real and imaginary values at a given frequency, click anywhere on the curve. The following figure shows a Nyquist plot with a data marker.

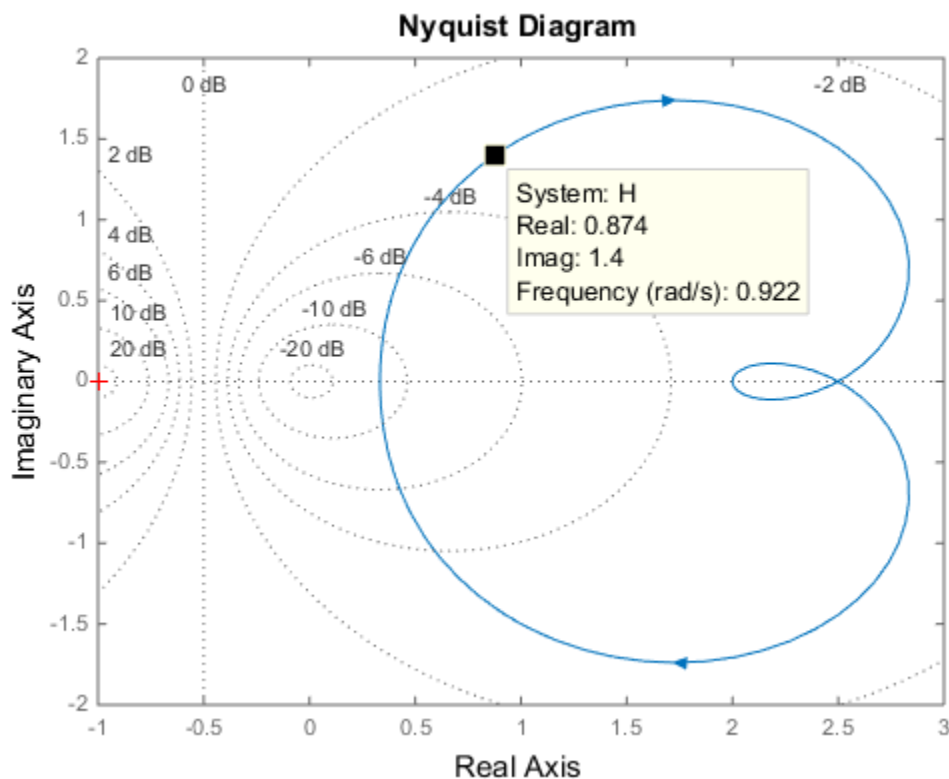

Version History

Introduced before R2006a

See Also

[getoptions](#) | [nyquist](#) | [setoptions](#) | [nyquistoptions](#)

Topics

“Customizing Response Plots from the Command Line”

obsv

Observability of state-space model

Syntax

`Ob = obsv(A,C)`

`Ob = obsv(sys)`

Description

A dynamic system is said to be *observable* if all its states can be known from the output of the system. `obsv` computes an observability matrix from state matrices or from a state-space model. You can use this matrix to determine observability.

For instance, consider a continuous-time state-space model with N_x states, N_y outputs, and N_u inputs:

$$\dot{x} = Ax + Bu$$

$$y = Cx + Du$$

Here, x , u and y represent the states, inputs and outputs respectively, while A , B , C and D are the state-space matrices with the following sizes:

- A is an N_x -by- N_x real-valued or complex-valued matrix.
- B is an N_x -by- N_u real-valued or complex-valued matrix.
- C is an N_y -by- N_x real-valued or complex-valued matrix.
- D is an N_y -by- N_u real-valued or complex-valued matrix.

The system is observable if the observability matrix generated by `obsv` $Ob = \begin{bmatrix} C \\ CA \\ CA^2 \\ \vdots \\ CA^{n-1} \end{bmatrix}$ has full rank,

that is, the rank is equal to the number of states in the state-space model. The observability matrix Ob has N_x rows and N_{xy} columns. For an example, see “Observability of SISO State-Space Model” on page 2-859.

`Ob = obsv(A,C)` returns the observability matrix Ob using the state matrix A and state-to-output matrix C . The system is observable if Ob has full rank, that is, the rank of Ob is equal to the number of states.

`Ob = obsv(sys)` returns the observability matrix of the state space model `sys`. This syntax is equivalent to:

`Ob = obsv(sys.A,sys.C);`

Examples

Check System Observability

Define A and C matrices.

```
A = [1  1;
     4 -2];
C = [-1 1;
     1 -1];
```

Compute observability matrix.

```
Ob = obsv(A,C);
```

Determine the number of unobservable states.

```
unobsv = length(A) - rank(Ob)
```

```
unobsv = 1
```

The unobservable state indicates that Ob does not have full rank 2. Therefore, the system is not observable.

Observability of SISO State-Space Model

For this example, consider the following SISO state-space model with 2 states:

$$A = \begin{bmatrix} -1.5 & -2 \\ 1 & 0 \end{bmatrix} \quad B = \begin{bmatrix} 0.5 \\ 0 \end{bmatrix} \quad C = [0 \ 1] \quad D = 1$$

Create the SISO state-space model defined by the following state-space matrices:

```
A = [-1.5, -2; 1, 0];
B = [0.5; 0];
C = [0, 1];
D = 1;
sys = ss(A,B,C,D);
```

Compute the observability matrix and find the rank.

```
Ob = obsv(sys)
```

```
Ob = 2×2
```

```
  0    1
  1    0
```

The size of the observability matrix depends on the size of the A and C matrices. For instance, if matrix A is an Nx-by-Nx matrix and matrix C is an Nx-by-Ny matrix, then the resultant matrix Ob has Nx rows and Ny columns. Here, Nx is the number of states and Ny is the number of outputs.

```
rank(Ob)
```

```
ans = 2
```

Since the rank of the observability matrix `Ob` is equal to the number of states, the system `sys` is observable.

Alternatively, you can also use just the `A` and `C` matrices to find the observability matrix.

```
Ob = obsv(sys.A,sys.C);  
rank(Ob)
```

```
ans = 2
```

Input Arguments

A — State matrix

`Nx`-by-`Nx` matrix

State matrix, specified as an `Nx`-by-`Nx` matrix where, `Nx` is the number of states.

C — State-to-output matrix

`Ny`-by-`Nx` matrix

State-to-output matrix, specified as an `Ny`-by-`Nx` matrix where, `Nx` is the number of states and `Ny` is the number of outputs.

sys — State-space model or model array

`ss` model object | `genss` model object | `uss` model object

State-space model or model array, specified as:

- A state-space (`ss`) model object, when the inputs `A`, `B`, `C` and `D` are numeric matrices or when converting from another model object type.
- A generalized state-space model (`genss`) object, when one or more of the matrices `A`, `B`, `C` and `D` includes tunable parameters, such as `realp` parameters or generalized matrices (`genmat`). The function uses the current values for tunable parameters.
- An uncertain state-space model (`uss`) object, when one or more of the inputs `A`, `B`, `C` and `D` includes uncertain matrices. The function uses the nominal values for uncertain parameters. Using uncertain models requires Robust Control Toolbox software.

Output Arguments

Ob — Observability matrix

array

Observability matrix, returned as an array. When `sys` is:

- A single state-space model with `Nx` states and `Ny` outputs, then the resultant array `Ob` has `Nx` rows and `Nxy` columns.
- An array of state-space models `sys(:, :, j1, ..., jN)`, then `Ob` is an array with `N+2` dimensions, that is, `Ob(:, :, j1, ..., jN)`.

Limitations

- obsv is not recommended for control design as computing the rank of the observability matrix is not recommended for observability testing. Ob will be numerically singular for most systems with more than a handful of states. This fact is well-documented under section III in [1].

Version History

Introduced before R2006a

References

- [1] Paige, C. C. "Properties of Numerical Algorithms Related to Computing Controllability." *IEEE Transactions on Automatic Control*. Vol. 26, Number 1, 1981, pp. 130-138.

See Also

obsvf | ctrb

External Websites

Video - A Conceptual Approach to Controllability and Observability

obsvf

Compute observability staircase form

Syntax

```
[Abar,Bbar,Cbar,T,k] = obsvf(A,B,C)
obsvf(A,B,C,tol)
```

Description

If the observability matrix of (A, C) has rank $r \leq n$, where n is the size of A , then there exists a similarity transformation such that

$$\bar{A} = TAT^T, \quad \bar{B} = TB, \quad \bar{C} = CT^T$$

where T is unitary and the transformed system has a *staircase* form with the unobservable modes, if any, in the upper left corner.

$$\bar{A} = \begin{bmatrix} A_{no} & A_{12} \\ 0 & A_o \end{bmatrix}, \quad \bar{B} = \begin{bmatrix} B_{no} \\ B_o \end{bmatrix}, \quad \bar{C} = [0 \ C_o]$$

where (C_o, A_o) is observable, and the eigenvalues of A_{no} are the unobservable modes.

`[Abar,Bbar,Cbar,T,k] = obsvf(A,B,C)` decomposes the state-space system with matrices A , B , and C into the observability staircase form $Abar$, $Bbar$, and $Cbar$, as described above. T is the similarity transformation matrix and k is a vector of length n , where n is the number of states in A . Each entry of k represents the number of observable states factored out during each step of the transformation matrix calculation [1]. The number of nonzero elements in k indicates how many iterations were necessary to calculate T , and $\text{sum}(k)$ is the number of states in A_o , the observable portion of $Abar$.

`obsvf(A,B,C,tol)` uses the tolerance `tol` when calculating the observable/unobservable subspaces. When the tolerance is not specified, it defaults to $10*n*\text{norm}(a,1)*\text{eps}$.

Examples

Form the observability staircase form of

$$A = \begin{bmatrix} 1 & 1 \\ 4 & -2 \end{bmatrix}$$

$$B = \begin{bmatrix} 1 & -1 \\ 1 & -1 \end{bmatrix}$$

$$C = \begin{bmatrix} 1 & 0 \\ 0 & 1 \end{bmatrix}$$

by typing

```
[Abar,Bbar,Cbar,T,k] = obsvf(A,B,C)
```

```
Abar =
```

```
 1    1  
 4   -2
```

```
Bbar =
```

```
 1    1  
 1   -1
```

```
Cbar =
```

```
 1    0  
 0    1
```

```
T =
```

```
 1    0  
 0    1
```

```
k =
```

```
 2    0
```

Algorithms

obsvf implements the Staircase Algorithm of [1] by calling ctrbf and using duality.

Version History

Introduced before R2006a

References

[1] Rosenbrock, M.M., *State-Space and Multivariable Theory*, John Wiley, 1970.

See Also

ctrbf | obsv

ord2

Generate continuous second-order systems

Syntax

```
[A,B,C,D] = ord2(wn,z)
[num,den] = ord2(wn,z)
```

Description

`[A,B,C,D] = ord2(wn,z)` generates the state-space description (A,B,C,D) of the second-order system

$$h(s) = \frac{1}{s^2 + 2\zeta\omega_n s + \omega_n^2}$$

given the natural frequency ω_n (ω_n) and damping factor ζ (ζ). Use `ss` to turn this description into a state-space object.

`[num,den] = ord2(wn,z)` returns the numerator and denominator of the second-order transfer function. Use `tf` to form the corresponding transfer function object.

Examples

To generate an LTI model of the second-order transfer function with damping factor $\zeta = 0.4$ and natural frequency $\omega_n = 2.4$ rad/sec., type

```
[num,den] = ord2(2.4,0.4)
num =
    1
den =
    1.0000    1.9200    5.7600
sys = tf(num,den)
Transfer function:
    1
-----
s^2 + 1.92 s + 5.76
```

Version History

Introduced before R2006a

See Also

`rss` | `ss` | `tf`

order

Query model order

Syntax

```
NS = order(sys)
```

Description

`NS = order(sys)` returns the model order `NS`. The order of a dynamic system model is the number of poles (for proper transfer functions) or the number of states (for state-space models). For improper transfer functions, the order is defined as the minimum number of states needed to build an equivalent state-space model (ignoring pole/zero cancellations).

`order(sys)` is an overloaded method that accepts SS, TF, and ZPK models. For LTI arrays, `NS` is an array of the same size listing the orders of each model in `sys`.

Caveat

`order` does not attempt to find minimal realizations of MIMO systems. For example, consider this 2-by-2 MIMO system:

```
s=tf('s');  
h = [1, 1/(s*(s+1)); 1/(s+2), 1/(s*(s+1)*(s+2))];  
order(h)  
ans =  
  
     6
```

Although `h` has a 3rd order realization, `order` returns 6. Use

```
order(ss(h, 'min'))
```

to find the minimal realization order.

Version History

Introduced in R2012a

See Also

`pole` | `balred`

pade

Padé approximation of models with time delay

Syntax

```
[num,den] = pade(T,N)
pade(T,N)
sysx = pade(sys,N)
sysx = pade(sys,NU,NY,NINT)
```

Description

`pade` approximates time delays for continuous-time LTI models. Such approximations are useful to model time delay effects such as transport and computation delays within the context of continuous-time systems. The Laplace transform of a time delay of T seconds is $\exp(-sT)$. This exponential transfer function is approximated by a rational transfer function using the Padé approximation formulas from [1].

To approximate discrete-time models, use `absorbDelay`.

See “Time Delays in Linear Systems” for more information about models with time delays.

`[num,den] = pade(T,N)` returns the Padé approximation of order N of the time delay T in transfer function form. The output row vectors `num` and `den` contain the numerator and denominator coefficients in descending powers of s . `num` and `den` are N th-order polynomials.

`pade(T,N)` plots the step and phase responses of the N th-order Padé approximation and compares them with the exact responses of the model with time delay T . The resultant Padé approximation has unit gain at all frequencies.

`sysx = pade(sys,N)` produces a delay-free approximation `sysx` of the continuous-time delay system `sys`. All delays are replaced by their N th-order Padé approximation.

`sysx = pade(sys,NU,NY,NINT)` specifies independent approximation orders for each input, output, and I/O or internal delay using vectors `NU`, `NY`, and `NINT`, respectively. You can use scalar values for `NU`, `NY`, or `NINT` to specify a uniform approximation order. You can also set some entries of `NU`, `NY`, or `NINT` to `Inf` to prevent approximation of the corresponding delays.

Examples

Second-Order Padé Approximation

For this example, compute the delay-free numerator and denominator coefficients for a time delay of 1.8 seconds for a second-order system.

```
T = 1.8;
N = 2;
[num,den] = pade(T,N)
```

```

num = 1×3
    1.0000   -3.3333    3.7037

den = 1×3
    1.0000    3.3333    3.7037

```

You can also plot the step and phase response of the delay-free approximation and the original system with time delay. Use the `pade` command without output arguments to generate the comparison plots.

```
pade(T,N)
```

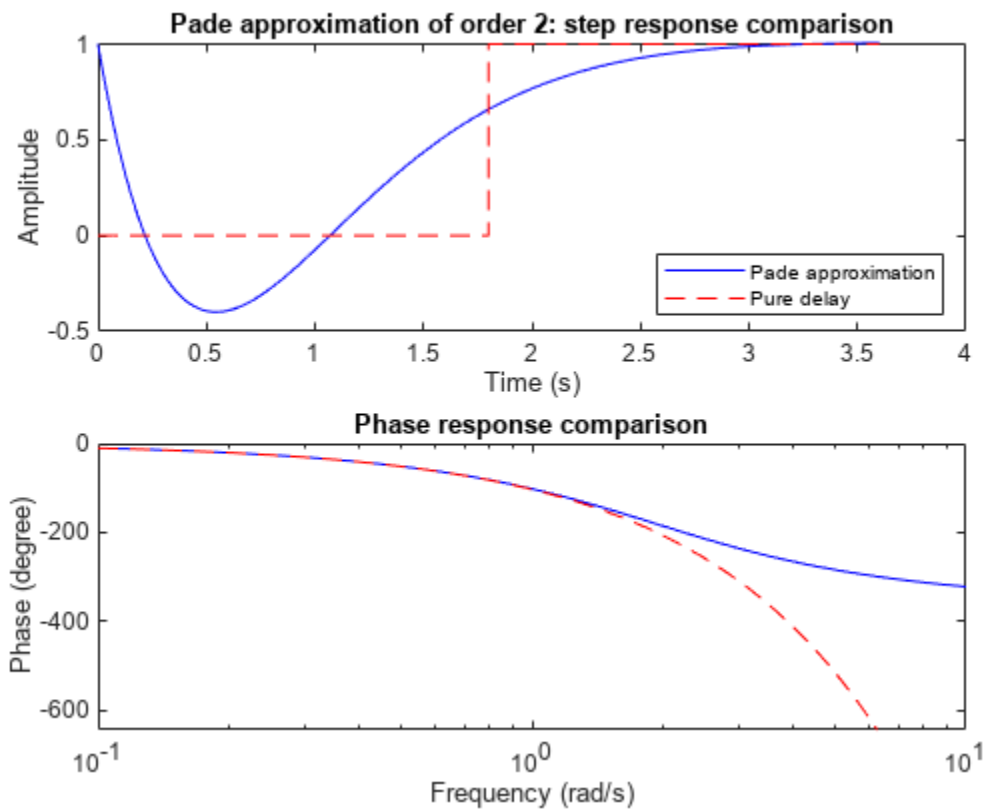

Padé Approximation of Continuous-Time Open-Loop Model

For this example, find the Padé approximation of the following continuous-time open loop system.

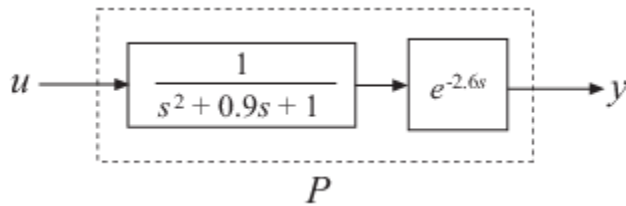

Create the open-loop system with an output delay.

```
s = tf('s');
T = 2.6;
sys = exp(-T*s)/(s^2+0.9*s+1)

sys =
```

$$\exp(-2.6*s) * \frac{1}{s^2 + 0.9 s + 1}$$

Continuous-time transfer function.

`sys` is a second-order transfer function (`tf`) object with a time delay.

Next, compute the first-order Padé approximation of `sys`.

```
sysx = pade(sys,1)

sysx =
```

$$\frac{-s + 0.7692}{s^3 + 1.669 s^2 + 1.692 s + 0.7692}$$

Continuous-time transfer function.

`pade` replaces all time delays in `sys` with a first-order approximation. Therefore, `sysx` is a third-order transfer function with no delays.

You can also plot and compare the step and phase response of the delay-free approximated model and the model with time-delay. Use the time delay and order values to create the plot.

```
pade(T,1)
```

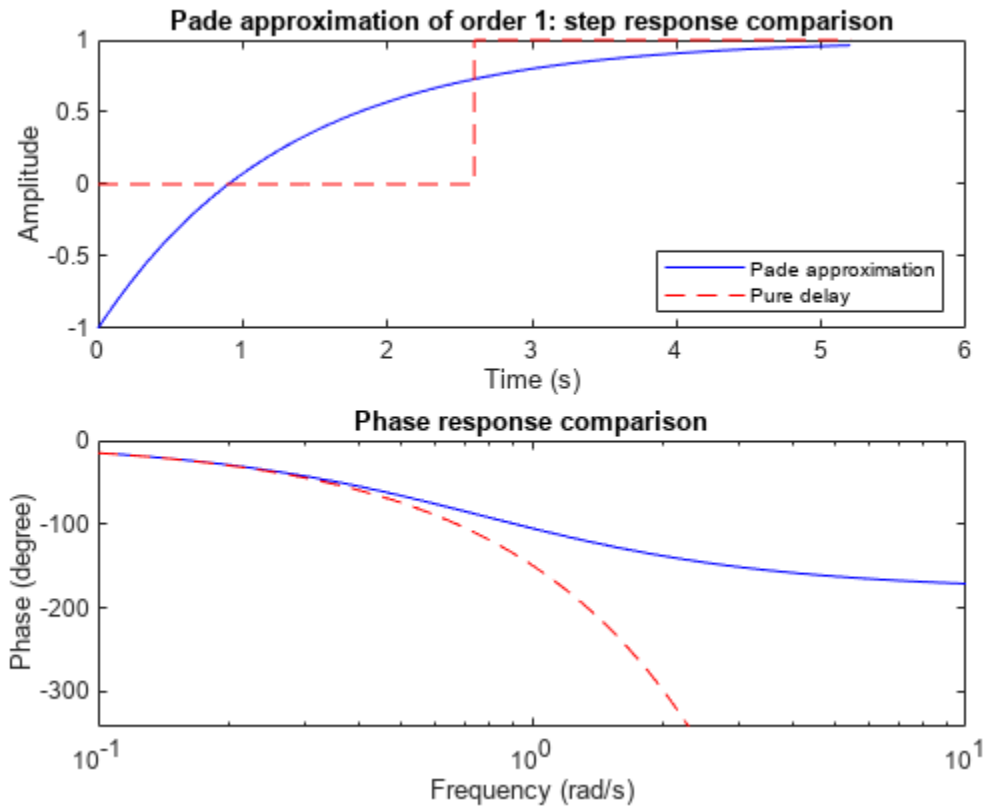

Third-Order Padé Approximation

Compute a third-order Padé approximation of a 0.1-second I/O delay.

```
s = tf('s');
sys = exp(-0.1*s);
sysx = pade(sys,3)
```

```
sysx =
```

```
-s^3 + 120 s^2 - 6000 s + 1.2e05
-----
s^3 + 120 s^2 + 6000 s + 1.2e05
```

Continuous-time transfer function.

Here, `sys` is a dynamic system representation of the exact time delay of 0.1 s. `sysx` is a transfer function that approximates that delay.

Compare the time and frequency responses of the true delay and its approximation. Calling the `pade` command without output arguments generates the comparison plots. In this case the first argument to `pade` is just the magnitude of the exact time delay, rather than a dynamic system representing the time delay.

```
pade(0.1,3)
```

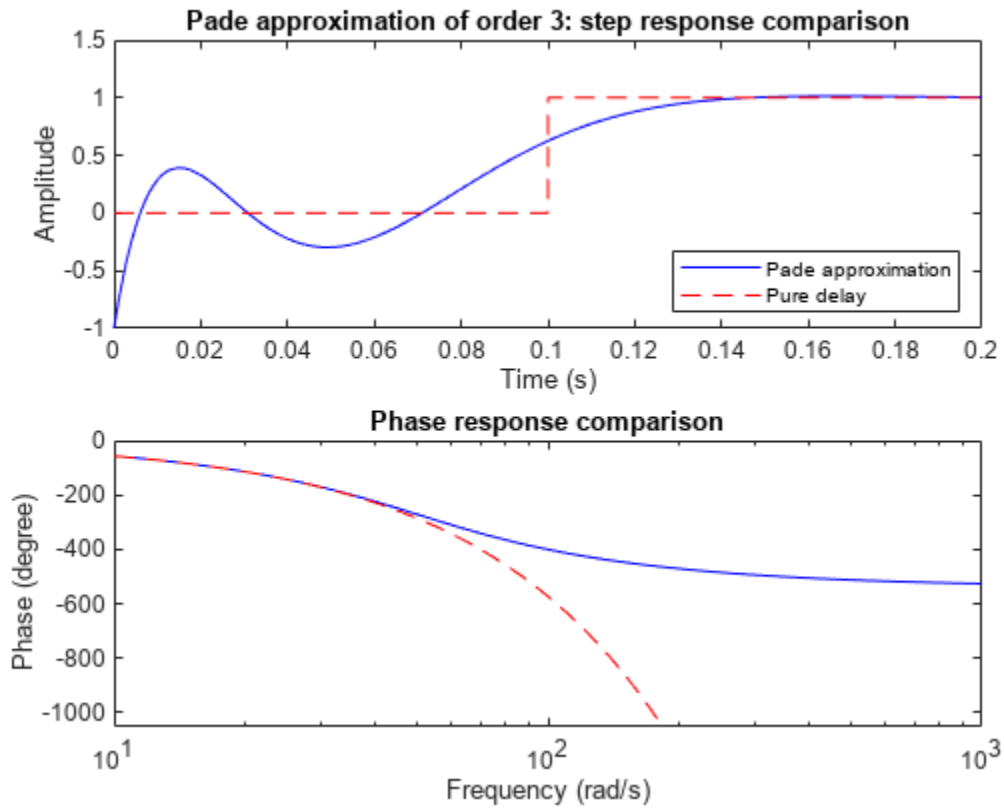

Padé Approximation of MIMO State-Space Model

For this example, consider the MIMO state-space model `sys` contained in `ssModel.mat`. `sys` has two inputs and three outputs, and contains input, output and internal delays.

Load the data and examine `sys`.

```
load('ssModel.mat','sys')
sys
```

```
sys =
```

```
A =
      x1      x2
x1  2.893    1.497
x2 -0.1138  -0.5279
```

```
B =
      u1      u2
x1 -1.334  -4.155
x2  1.127  -0.06161
```

```
C =
      x1      x2
y1 -2.416  -0.6317
```



```

y2  1.688  1.063
y3  3.509  1.84

```

D =

```

      u1      u2
y1  1.019  1.999
y2   0    -3.658
y3   0    -5.885

```

(values computed with all internal delays set to zero)

```

Input delays (seconds): 1.5  0.3
Output delays (seconds): 0.2  0.8  1.3
Internal delays (seconds): 2.1  1.3

```

Continuous-time state-space model.

Specify the approximation orders for the input, output, and internal delays, and compute the Padé approximation. Set approximation orders to Inf to prevent approximation of the corresponding delays.

```

NU = [3 Inf];
NY = [1 Inf 2];
NINT = [Inf 2];
sysx = pade(sys,NU,NY,NINT)

```

sysx =

```

A =
      x1      x2      x3      x4      x5      x6      x7
x1   -10      0      0   -9.665   -2.527   -7.305      0
x2     0   -4.615   -3.55   14.04    7.358   21.51      0
x3     0      2      0      0      0      0      0
x4     0      0      0    2.893    1.497    4.115      0
x5     0      0      0   -0.1138   -0.5279   -0.2169      0
x6     0      0      0   -8.011   -3.193   -4.615   -3.55
x7     0      0      0      0      0      2      0
x8     0      0      0      0      0      0      0
x9     0      0      0      0      0      0      0
x10    0      0      0      0      0      0      0

```

```

      x8      x9      x10
x1   16.3      0    4.527
x2     0      0      0
x3     0      0      0
x4   -5.335      0   -1.482
x5     4.51      0    1.253
x6     0      0      0
x7     0      0      0
x8     -8   -6.667   -2.222
x9     4      0      0
x10    0      4      0

```

B =

```

      u1      u2
x1  -4.075    7.996
x2     0   -23.54
x3     0      0

```

```

x4      1.334      -4.155
x5     -1.127     -0.06161
x6       0         10.1
x7       0         0
x8       4         0
x9       0         0
x10      0         0

```

```

C =
      x1      x2      x3      x4      x5      x6      x7      x8
y1      5       0       0      2.416  0.6317  1.826  0     -4.075
y2      0       0       0      1.688  1.063  3.074  0       0
y3      0     -2.308  0      3.509  1.84   5.377  0       0

      x9      x10
y1      0     -1.132
y2      0       0
y3      0       0

```

```

D =
      u1      u2
y1     1.019  -1.999
y2      0     -3.658
y3      0     -5.885

```

(values computed with all internal delays set to zero)

```

Input delays (seconds): 0  0.3
Output delays (seconds): 0  0.8  0
Internal delays (seconds): 2.1

```

Continuous-time state-space model.

The resultant approximation `sysx` still has specific input, output, and internal delays where the corresponding approximation orders are `Inf`.

Input Arguments

T — Time delay

positive scalar

Time delay value, specified as a positive scalar. The Padé approximation of a zero delay ($T = 0$) is always unit gain.

N — Desired order of continuous-time approximation model

positive integer

Desired order of the continuous-time approximation model, specified as a positive integer.

sys — Dynamic system with time delay

dynamic system model

Dynamic system with time delay, specified as a SISO or MIMO dynamic system model. Dynamic systems that you can use include:

- Continuous-time LTI models, such as `tf`, `zpk`, and `ss` models.
- Sparse models, such as `spars` and `mechss` models.
- Generalized or uncertain LTI models such as `genss` or `uss` models. (Using uncertain models requires a Robust Control Toolbox license.)

The resulting model assumes

- Current values of the tunable components for tunable control design blocks
- Nominal model values for uncertain control design blocks
- Frequency response `frd` models. For frequency response models, use the `delay2z` command to absorb delays into the frequency response without approximation.

For discrete-time models, use `absorbDelay`.

NU — Approximation orders for the input channel

scalar | vector | `Inf`

Approximation orders for the input channel, specified as

- A scalar, to use the same approximation order across all the inputs.
- A vector, to specify individual approximation order values per input. You can use `Inf` for specific inputs to prevent approximation of corresponding delays.

NY — Approximation orders for the output channel

scalar | vector | `Inf`

Approximation orders for the output channel, specified as

- A scalar, to use the same approximation order across all the outputs.
- A vector, to specify individual approximation order values per output. You can use `Inf` for specific outputs to prevent approximation of corresponding delays.

NINT — Approximation orders for I/O delay or output delay

scalar | vector | `Inf`

Approximation orders for I/O delay (transfer functions or zero-pole-gain models) or internal delay (state-space models), specified as

- A scalar, to use the same approximation order across all the I/O or internal delays.
- A vector, to specify individual approximation order values per I/O or internal delay. You can use `Inf` for specific I/Os to prevent approximation of corresponding delays.

Output Arguments

num — Numerator coefficients of delay-free transfer function

row vector

Numerator coefficients of delay-free transfer function, returned as a row vector.

den — Denominator coefficients of delay-free transfer function

row vector

Denominator coefficients of delay-free transfer function, returned as a row vector.

sysx — Padé approximated system

model object

Padé approximated system, returned as a model object of the same type as `sys`.

Limitations

- Padé approximation is valid only at low frequencies and provides better frequency-domain approximation than time-domain approximation. Therefore, compare the true and approximate responses to choose the right approximation order and check the approximation validity.
- High-order Padé approximations produce transfer functions with clustered poles. Because such pole configurations tend to be very sensitive to perturbations, avoid Padé approximations with order $N > 10$.

Version History

Introduced before R2006a

References

- [1] Golub, Gene H., and Charles F. Van Loan. Matrix Computations. 2nd ed. Johns Hopkins Series in the Mathematical Sciences 3. Baltimore, Md: Johns Hopkins University Press, 1989. pp. 557-558.

See Also`c2d` | `absorbDelay` | `thiran` | `delay2z`**Topics**

“Time-Delay Approximation”

“Time Delays in Linear Systems”

parallel

Parallel connection of two models

Syntax

```
parallel
sys = parallel(sys1,sys2)
sys = parallel(sys1,sys2,inp1,inp2,out1,out2)
sys = parallel(sys1,sys2,'name')
```

Description

`parallel` connects two model objects in parallel. This function accepts any type of model. The two systems must be either both continuous or both discrete with identical sample time. Static gains are neutral and can be specified as regular matrices.

`sys = parallel(sys1,sys2)` forms the basic parallel connection shown in the following figure.

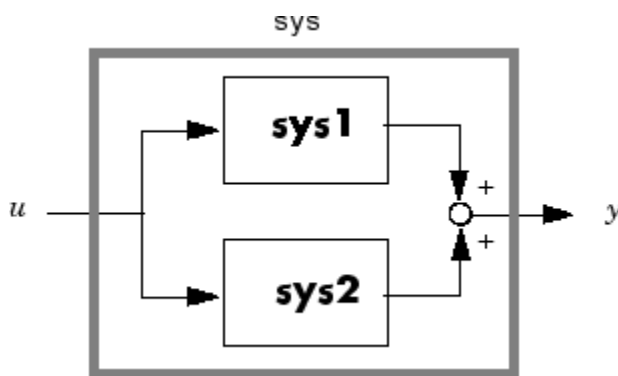

This command equals the direct addition

```
sys = sys1 + sys2
```

`sys = parallel(sys1,sys2,inp1,inp2,out1,out2)` forms the more general parallel connection shown in the following figure.

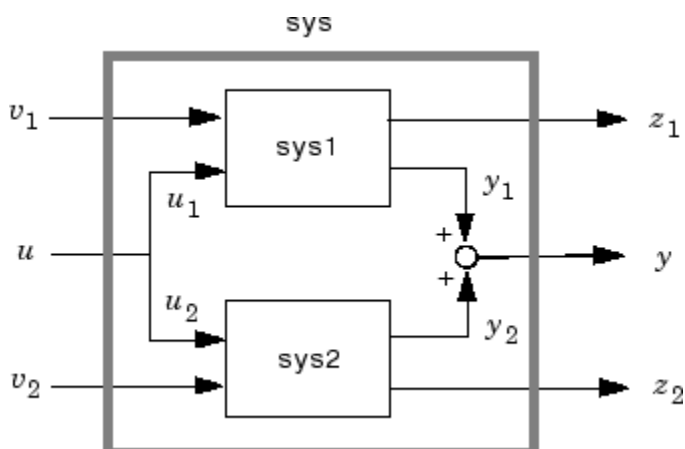

The vectors `inp1` and `inp2` contain indexes into the input channels of `sys1` and `sys2`, respectively, and define the input channels u_1 and u_2 in the diagram. Similarly, the vectors `out1` and `out2` contain indexes into the outputs of these two systems and define the output channels y_1 and y_2 in the diagram. The resulting model `sys` has $[v_1 ; u ; v_2]$ as inputs and $[z_1 ; y ; z_2]$ as outputs.

`sys = parallel(sys1,sys2,'name')` connects `sys1` and `sys2` by matching I/O names. You must specify all I/O names of `sys1` and `sys2`. The matching names appear in `sys` in the same order as in `sys1`. For example, the following specification:

```
sys1 = ss(eye(3),'InputName',{'C','B','A'},'OutputName',{'Z','Y','X'});
sys2 = ss(eye(3),'InputName',{'A','C','B'},'OutputName',{'X','Y','Z'});
parallel(sys1,sys2,'name')
```

returns this result:

```
d =
      C  B  A
Z   1  1  0
Y   1  1  0
X   0  0  2
```

Static gain.

Note If `sys1` and `sys2` are model arrays, `parallel` returns model array `sys` of the same size, where `sys(:, :, k) = parallel(sys1(:, :, k), sys2(:, :, k), inp1, ...)`.

Examples

See Kalman Filtering for an example.

Version History

Introduced before R2006a

See Also

[append](#) | [feedback](#) | [series](#)

particleFilter

Particle filter object for online state estimation

Description

A particle filter is a recursive, Bayesian state estimator that uses discrete particles to approximate the posterior distribution of an estimated state. It is useful for online state estimation when measurements and a system model, that relates model states to the measurements, are available. The particle filter algorithm computes the state estimates recursively and involves initialization, prediction, and correction steps.

`particleFilter` creates an object for online state estimation of a discrete-time nonlinear system using the discrete-time particle filter algorithm.

Consider a plant with states x , input u , output m , process noise w , and measurement y . Assume that you can represent the plant as a nonlinear system.

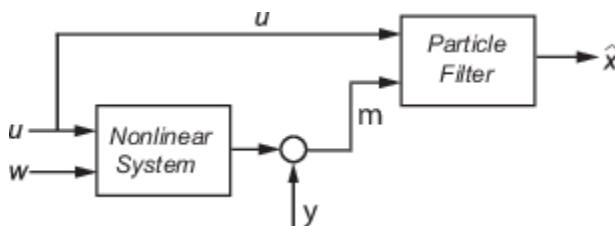

The algorithm computes the state estimates \hat{x} of the nonlinear system using the state transition and measurement likelihood functions you specify.

The software supports arbitrary nonlinear state transition and measurement models, with arbitrary process and measurement noise distributions.

To perform online state estimation, create the nonlinear state transition function and measurement likelihood function. Then construct the `particleFilter` object using these nonlinear functions. After you create the object:

- 1 Initialize the particles using the `initialize` command.
- 2 Predict state estimates at the next step using the `predict` command.
- 3 Correct the state estimates using the `correct` command.

The prediction step uses the latest state to predict the next state based on the state transition model you provide. The correction step uses the current sensor measurement to correct the state estimate. The algorithm optionally redistributes, or resamples, the particles in the state space to match the posterior distribution of the estimated state. Each particle represents a discrete state hypothesis of these state variables. The set of all particles is used to help determine the state estimate.

Creation

Syntax

```
pf = particleFilter(StateTransitionFcn,MeasurementLikelihoodFcn)
```

Object Description

`pf = particleFilter(StateTransitionFcn,MeasurementLikelihoodFcn)` creates a particle filter object for online state estimation of a discrete-time nonlinear system. `StateTransitionFcn` is a function that calculates the particles (state hypotheses) at the next time step, given the state vector at a time step. `MeasurementLikelihoodFcn` is a function that calculates the likelihood of each particle based on sensor measurements.

After creating the object, use the `initialize` command to initialize the particles with a known mean and covariance or uniformly distributed particles within defined bounds. Then, use the `correct` and `predict` commands to update particles (and hence the state estimate) using sensor measurements.

Input Arguments

StateTransitionFcn — State transition function

function handle

State transition function, specified as a function handle, determines the transition of particles (state hypotheses) between time steps. Also a property of the `particleFilter` object. For more information, see “Properties” on page 2-878.

MeasurementLikelihoodFcn — Measurement likelihood function

function handle

Measurement likelihood function, specified as a function handle, is used to calculate the likelihood of particles (state hypotheses) from sensor measurements. Also a property of the `particleFilter` object. For more information, see “Properties” on page 2-878.

Properties

NumStateVariables — Number of state variables

[] (default) | scalar

Number of state variables, specified as a scalar. This property is read-only and is set using `initialize`. The number of states is implicit based on the specified matrices for the initial mean of particles, or the state bounds.

NumParticles — Number of particles used in the filter

[] (default) | scalar

Number of particles used in the filter, specified as a scalar. Each particle represents a state hypothesis. You specify this property only by using `initialize`.

StateTransitionFcn — State transition function

function handle

State transition function, specified as a function handle, determines the transition of particles (state hypotheses) between time steps. This function calculates the particles at the next time step, including the process noise, given particles at a time step.

In contrast, the state transition function for the `extendedKalmanFilter` and `unscentedKalmanFilter` generates a single state estimate at a given time step.

You write and save the state transition function for your nonlinear system, and specify it as a function handle when constructing the `particleFilter` object. For example, if `vdpParticleFilterStateFcn.m` is the state transition function, specify `StateTransitionFcn` as `@vdpParticleFilterStateFcn`. You can also specify `StateTransitionFcn` as a function handle to an anonymous function.

The function signature is as follows:

```
function predictedParticles = myStateTransitionFcn(previousParticles,varargin)
```

The `StateTransitionFcn` function accepts at least one input argument. The first argument is the set of particles `previousParticles` that represents the state hypotheses at the previous time step. The optional use of `varargin` in the function enables you to input any extra parameters that are relevant for predicting the next state, using `predict`, as follows:

```
predict(pf, arg1, arg2)
```

If `StateOrientation` is 'column', then `previousParticles` is a `NumStateVariables`-by-`NumParticles` array. If `StateOrientation` is 'row', then `previousParticles` is a `NumParticles`-by-`NumStateVariables` array.

`StateTransitionFcn` must return exactly one output, `predictedParticles`, which is the set of predicted particle locations for the current time step (array with same dimensions as `previousParticles`).

`StateTransitionFcn` must include the random process noise (from any distribution suitable for your application) in the `predictedParticles`.

To see an example of a state transition function with the `StateOrientation` property set to 'column', type `edit vdpParticleFilterStateFcn` at the command line.

MeasurementLikelihoodFcn — Measurement likelihood function

function handle

Measurement likelihood function, specified as a function handle, is used to calculate the likelihood of particles (state hypotheses) using the sensor measurements. For each state hypothesis (particle), the function first calculates an `N`-element measurement hypothesis vector. Then the likelihood of each measurement hypothesis is calculated based on the sensor measurement and the measurement noise probability distribution.

In contrast, the measurement function for `extendedKalmanFilter` and `unscentedKalmanFilter` takes a single state hypothesis and returns a single measurement estimate.

You write and save the measurement likelihood function based on your measurement model, and use it to construct the object. For example, if `vdpMeasurementLikelihoodFcn.m` is the measurement likelihood function, specify `MeasurementLikelihoodFcn` as `@vdpMeasurementLikelihoodFcn`. You can also specify `MeasurementLikelihoodFcn` as a function handle to an anonymous function.

The function signature is as follows:

```
function likelihood = myMeasurementLikelihoodFcn(predictedParticles,measurement,varargin)
```

The `MeasurementLikelihoodFcn` function accepts at least two input arguments. The first argument is the set of particles `predictedParticles` that represents the predicted state hypothesis. If `StateOrientation` is 'column', then `predictedParticles` is a `NumStateVariables-by-NumParticles` array. If `StateOrientation` is 'row', then `predictedParticles` is a `NumParticles-by-NumStateVariables` array. The second argument, `measurement`, is the N-element sensor measurement at the current time step. You can provide additional input arguments using `varargin`.

The `MeasurementLikelihoodFcn` must return exactly one output, `likelihood`, a vector with `NumParticles` length, which is the likelihood of the given measurement for each particle (state hypothesis).

To see an example of a measurement likelihood function, type `edit vdpMeasurementLikelihoodFcn` at the command line.

IsStateVariableCircular – Whether the state variables have a circular distribution

[] (default) | logical array

Whether the state variables have a circular distribution, specified as a logical array.

This is a read-only property and is set using `initialize`.

Circular (or angular) distributions use a probability density function with a range of $[-\pi, \pi]$. `IsStateVariableCircular` is a row-vector with `NumStateVariables` elements. Each vector element indicates whether the associated state variable is circular.

ResamplingPolicy – Policy settings that determine when to trigger resampling

`particleResamplingPolicy` object

Policy settings that determine when to trigger resampling, specified as a `particleResamplingPolicy` object.

The resampling of particles is a vital step in estimating states using a particle filter. It enables you to select particles based on the current state, instead of using the particle distribution given at initialization. By continuously resampling the particles around the current estimate, you can get more accurate tracking and improve long-term performance.

You can trigger resampling either at fixed intervals or dynamically, based on the number of effective particles. The minimum effective particle ratio is a measure of how well the current set of particles approximates the posterior distribution. The number of effective particles is calculated by:

$$N_{eff} = \frac{1}{\sum_{i=1}^N (w^i)^2}$$

In this equation, `N` is the number of particles, and `w` is the normalized weight of each particle. The effective particle ratio is then `Neff / NumParticles`. Therefore, the effective particle ratio is a function of the weights of all the particles. After the weights of the particles reach a low enough value, they are not contributing to the state estimation. This low value triggers resampling, so the particles are closer to the current state estimation and have higher weights.

The following properties of the `particleResamplingPolicy` object can be modified to control when resampling is triggered:

Description
<p>Property</p> <p>It is a method to determine when resampling occurs, based on the value chosen. The 'interval' value triggers resampling at regular time steps of the particle filter operation. The 'ratio' value triggers resampling based on the ratio of effective total particles.</p> <p>Method</p> <p>(Method)</p> <p>interval</p>
<p>Fixed interval between resampling, specified as a scalar. This interval determines during which correction steps the resampling is executed. For example, a value of 2 means the resampling is executed every second correction step. A value of <code>inf</code> means that resampling is never executed.</p> <p>This property only applies with the <code>TriggerMethod</code> is set to 'interval'.</p> <p>interval</p>

Description
<p>Effective Particle Ratio</p> <p>MinEffectiveParticleRatio is the minimum desired ratio of the effective number of particles to the total number of particles NumParticles. The effective number of particles is a measure of how well the current set of particles approximates the posterior distribution. A lower effective particle ratio implies that a lower number of particles are contributing to the estimation and resampling is required.</p> <p>If the ratio of the effective number of particles to the total number of particles NumParticles falls below the MinEffectiveParticleRatio, a resampling step is triggered.</p> <p>Resampling Method</p>

ResamplingMethod — Method used for particle resampling

'multinomial' (default) | 'residual' | 'stratified' | 'systematic'

Method used for particle resampling, specified as one of the following:

- 'multinomial' — Multinomial resampling, also called simplified random sampling, generates N random numbers independently from the uniform distribution in the open interval $(0, 1)$ and uses them to select particles proportional to their weight.
- 'residual' — Residual resampling consists of two stages. The first stage is a deterministic replication of each particle that have weights larger than $1/N$. The second stage consists of random sampling using the remainder of the weights (labelled as residuals).
- 'stratified' — Stratified resampling divides the whole population of particles into subsets called strata. It pre-partitions the $(0, 1)$ interval into N disjoint sub-intervals of size $1/N$. The random numbers are drawn independently in each of these sub-intervals and the sample indices chosen in the strata.
- 'systematic' — Systematic resampling is similar to stratified resampling as it also makes use of strata. One distinction is that it only draws one random number from the open interval $(0, 1/N)$ and the remaining sample points are calculated deterministically at a fixed $1/N$ step size.

StateEstimationMethod — Method used for extracting a state estimate from particles

'mean' (default) | 'maxweight'

Method used for extracting a state estimate from particles, specified as one of the following:

- 'mean' - The object outputs the weighted mean of the particles, depending on the properties `Weights` and `Particles`, as the state estimate.
- 'maxweight' - The object outputs the particle with the highest weight as the state estimate.

Particles — Array of particle values

[] (default) | array

Array of particle values, specified as an array based on the `StateOrientation` property:

- If `StateOrientation` is 'row' then `Particles` is an `NumParticles`-by-`NumStateVariables` array.
- If `StateOrientation` is 'column' then `Particles` is an `NumStateVariables`-by-`NumParticles` array.

Each row or column corresponds to a state hypothesis (a single particle).

Weights — Particle weights

[] (default) | vector

Particle weights, defined as a vector based on the value of the `StateOrientation` property:

- If `StateOrientation` is 'row' then `Weights` is a `NumParticles`-by-1 vector, where each weight is associated with the particle in the same row in the `Particles` property.
- If `StateOrientation` is 'column' then `Weights` is a 1-by-`NumParticles` vector, where each weight is associated with the particle in the same column in the `Particles` property.

State — Current state estimate

[] (default) | vector

Current state estimate, defined as a vector based on the value of the `StateOrientation` property:

- If `StateOrientation` is 'row' then `State` is a 1-by-`NumStateVariables` vector
- If `StateOrientation` is 'column' then `State` is a `NumStateVariables`-by-1 vector

`State` is a read-only property, and is derived from `Particles` based on the `StateEstimationMethod` property. Refer to “`StateEstimationMethod`” on page 2-0 for details on how the value of `State` is determined.

`State` along with `StateCovariance` can also be determined using `getStateEstimate`.

StateCovariance — Current estimate of state estimation error covariance`NumStateVariables`-by-`NumStateVariables` array (default) | [] | array

Current estimate of state estimation error covariance, defined as an `NumStateVariables`-by-`NumStateVariables` array. `StateCovariance` is a read-only property and is calculated based on the `StateEstimationMethod`. If you specify a state estimation method that does not support covariance, then the function returns `StateCovariance` as [].

`StateCovariance` and `State` can be determined together using `getStateEstimate`.

Object Functions

initialize	Initialize the state of the particle filter
predict	Predict state and state estimation error covariance at next time step using extended or unscented Kalman filter, or particle filter
correct	Correct state and state estimation error covariance using extended or unscented Kalman filter, or particle filter and measurements
getStateEstimate	Extract best state estimate and covariance from particles
clone	Copy online state estimation object

Examples

Create Particle Filter Object for Online State Estimation

To create a particle filter object for estimating the states of your system, create appropriate state transition function and measurement likelihood function for the system.

In this example, the function `vdpParticleFilterStateFcn` describes a discrete-time approximation to van der Pol oscillator with nonlinearity parameter, μ , equal to 1. In addition, it models Gaussian process noise. `vdpMeasurementLikelihood` function calculates the likelihood of particles from the noisy measurements of the first state, assuming a Gaussian measurement noise distribution.

Create the particle filter object. Use function handles to provide the state transition and measurement likelihood functions to the object.

```
myPF = particleFilter(@vdpParticleFilterStateFcn,@vdpMeasurementLikelihoodFcn);
```

To initialize and estimate the states and state estimation error covariance from the constructed object, use the `initialize`, `predict`, and `correct` commands.

Copyright 2012 The MathWorks, Inc..

Estimate States Online using Particle Filter

Load the van der Pol ODE data, and specify the sample time.

`vdpODEdata.mat` contains a simulation of the van der Pol ODE with nonlinearity parameter $\mu=1$, using `ode45`, with initial conditions $[2;0]$. The true state was extracted with sample time $dt = 0.05$.

```
addpath(fullfile(matlabroot,'examples','control','main')) % add example data
```

```
load ('vdpODEdata.mat','xTrue','dt')
tSpan = 0:dt:5;
```

Get the measurements. For this example, a sensor measures the first state with a Gaussian noise with standard deviation 0.04 .

```
sqrR = 0.04;
yMeas = xTrue(:,1) + sqrR*randn(numel(tSpan),1);
```

Create a particle filter, and set the state transition and measurement likelihood functions.

```
myPF = particleFilter(@vdpParticleFilterStateFcn,@vdpMeasurementLikelihoodFcn);
```

Initialize the particle filter at state $[2; 0]$ with unit covariance, and use 1000 particles.

```
initialize(myPF,1000,[2;0],eye(2));
```

Pick the mean state estimation and systematic resampling methods.

```
myPF.StateEstimationMethod = 'mean';
myPF.ResamplingMethod = 'systematic';
```

Estimate the states using the correct and predict commands, and store the estimated states.

```
xEst = zeros(size(xTrue));
for k=1:size(xTrue,1)
    xEst(k,:) = correct(myPF,yMeas(k));
    predict(myPF);
end
```

Plot the results, and compare the estimated and true states.

```
figure(1)
plot(xTrue(:,1),xTrue(:,2),'x',xEst(:,1),xEst(:,2),'ro')
legend('True','Estimated')
```

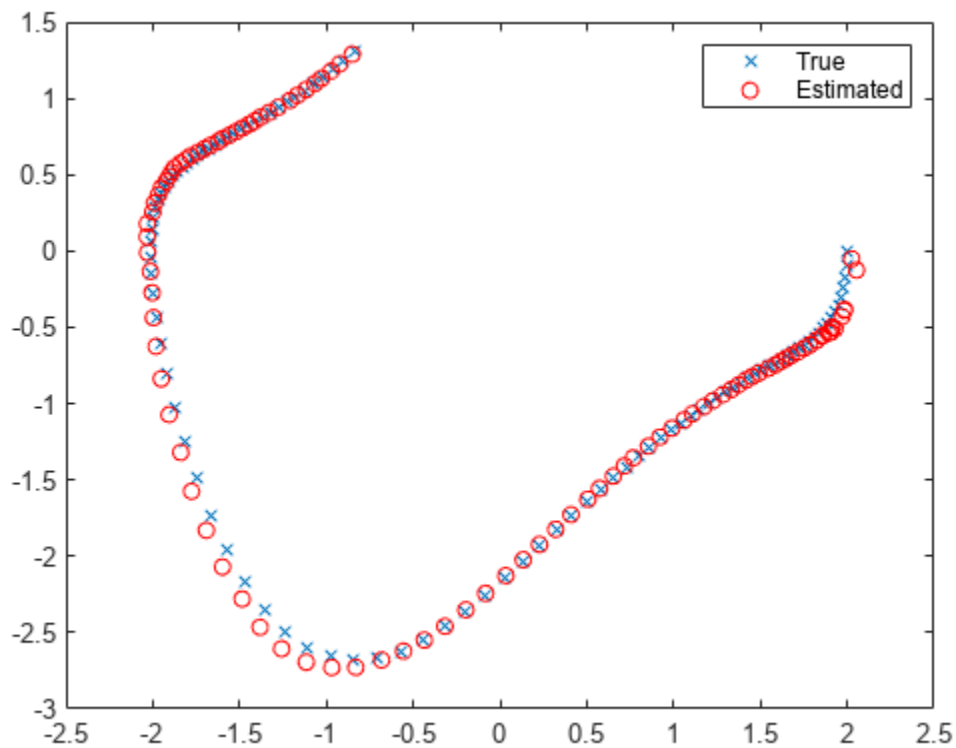

```
rmpath(fullfile(matlabroot,'examples','control','main')) % remove example data
```

Version History

Introduced in R2017b

References

- [1] T. Li, M. Bolic, P.M. Djuric, "Resampling Methods for Particle Filtering: Classification, implementation, and strategies," *IEEE Signal Processing Magazine*, vol. 32, no. 3, pp. 70-86, May 2015.

Extended Capabilities

C/C++ Code Generation

Generate C and C++ code using MATLAB® Coder™.

Usage notes and limitations:

For more information, see "Generate Code for Online State Estimation in MATLAB".

Supports MATLAB Function block: No

See Also

Functions

`initialize` | `predict` | `correct` | `clone` | `unscentedKalmanFilter` | `extendedKalmanFilter`

Topics

"Nonlinear State Estimation Using Unscented Kalman Filter and Particle Filter"

"Generate Code for Online State Estimation in MATLAB"

"Validate Online State Estimation at the Command Line"

"Troubleshoot Online State Estimation"

External Websites

Understanding Kalman Filters: Nonlinear State Estimators — MATLAB Video Series

passiveplot

Compute or plot passivity index as function of frequency

Syntax

```
passiveplot(G)
passiveplot(G,type)
passiveplot( ____,w)
passiveplot(G1,G2,...,GN, ____)
passiveplot(G1,LineSpec1,...,GN,LineSpecN, ____)
passiveplot( ____,plotoptions)
```

```
[index,wout] = passiveplot(G)
[index,wout] = passiveplot(G,type)
index = passiveplot(G,w)
index = passiveplot(G,type,w)
```

Description

`passiveplot(G)` plots the relative passivity indices of the dynamic system G as a function of frequency. When $I + G$ is minimum phase, the relative passivity indices are the singular values of $(I - G)(I + G)^{-1}$. The largest singular value measures the relative excess ($R < 1$) or shortage ($R > 1$) at each frequency. See `getPassiveIndex` for more information about the meaning of the passivity index.

`passiveplot` automatically chooses the frequency range and number of points for the plot based on the dynamics of G .

If G is a model with complex coefficients, then in:

- Log frequency scale, the plot shows two branches, one for positive frequencies and one for negative frequencies. The arrows indicate the direction of increasing frequency values for each branch.
- Linear frequency scale, the plot shows a single branch with a symmetric frequency range centered at a frequency value of zero.

`passiveplot(G,type)` plots the input, output, or I/O passivity index, depending on the value of `type`: 'input', 'output', or 'io', respectively.

`passiveplot(____,w)` plots the passivity index for frequencies specified by w .

- If w is a cell array of the form $\{w_{min}, w_{max}\}$, then `passiveplot` plots the passivity index at frequencies ranging between w_{min} and w_{max} .
- If w is a vector of frequencies, then `passiveplot` plots the passivity index at each specified frequency. The vector w can contain both negative and positive frequencies.

You can use this syntax with any of the previous input-argument combinations.

`passiveplot(G1,G2,...,GN, ___)` plots the passivity index for multiple dynamic systems G_1, G_2, \dots, G_N on the same plot. You can also use this syntax with the `type` input argument, with `w` to specify frequencies to plot, or both.

`passiveplot(G1,LineStyle1,...,GN,LineStyleN, ___)` specifies a color, linestyle, and marker for each system in the plot.

`passiveplot(___, plotoptions)` plots the passivity index with the options set specified in `plotoptions`. You can use these options to customize the plot appearance using the command line. Settings you specify in `plotoptions` override the preference settings in the MATLAB session in which you run `passiveplot`. Therefore, this syntax is useful when you want to write a script to generate multiple plots that look the same regardless of the local preferences.

`[index,wout] = passiveplot(G)` and `[index,wout] = passiveplot(G,type)` return the passivity index at each frequency in the vector `wout`. The output `index` is a matrix, and the value `index(:,k)` gives the passivity indices in descending order at the frequency `w(k)`. This syntax does not draw a plot.

`index = passiveplot(G,w)` and `index = passiveplot(G,type,w)` return the passivity indices at the frequencies specified by `w`.

Examples

Plot Passivity Versus Frequency

Plot the relative passivity index as a function of frequency of the system $G = (s + 2)/(s + 1)$.

```
G = tf([1 2],[1 1]);  
passiveplot(G)
```

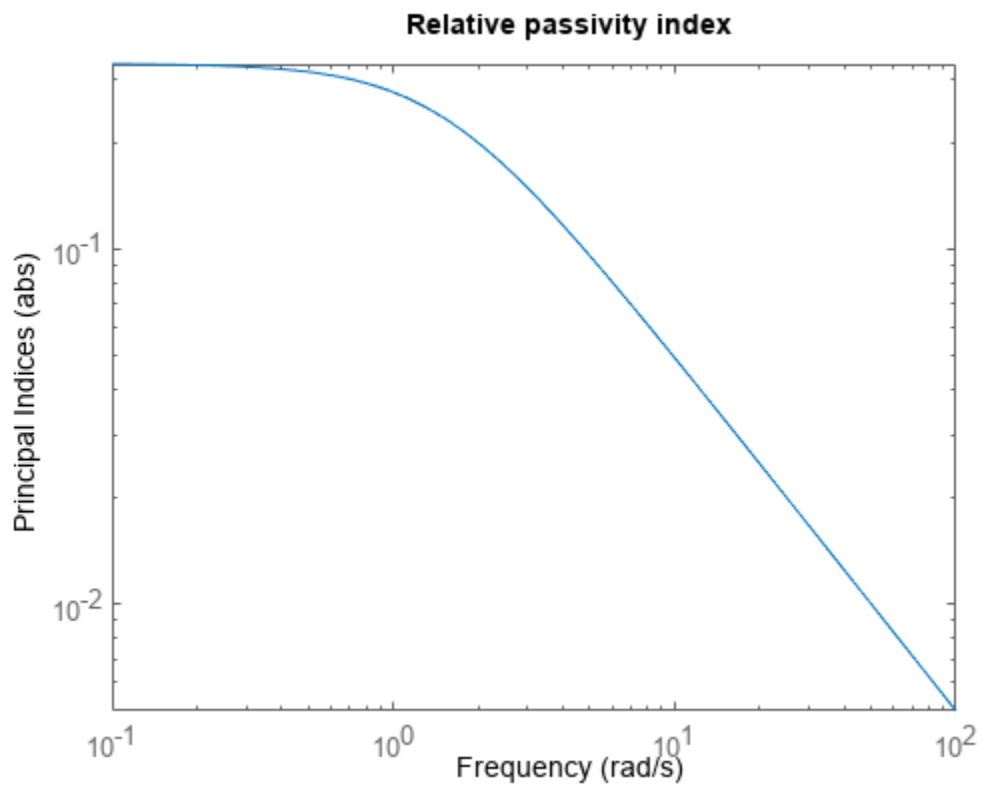

The plot shows that the relative passivity index is less than 1 at all frequencies. Therefore, the system G is passive.

Plot the input passivity index of the same system.

```
passiveplot(G, 'input')
```

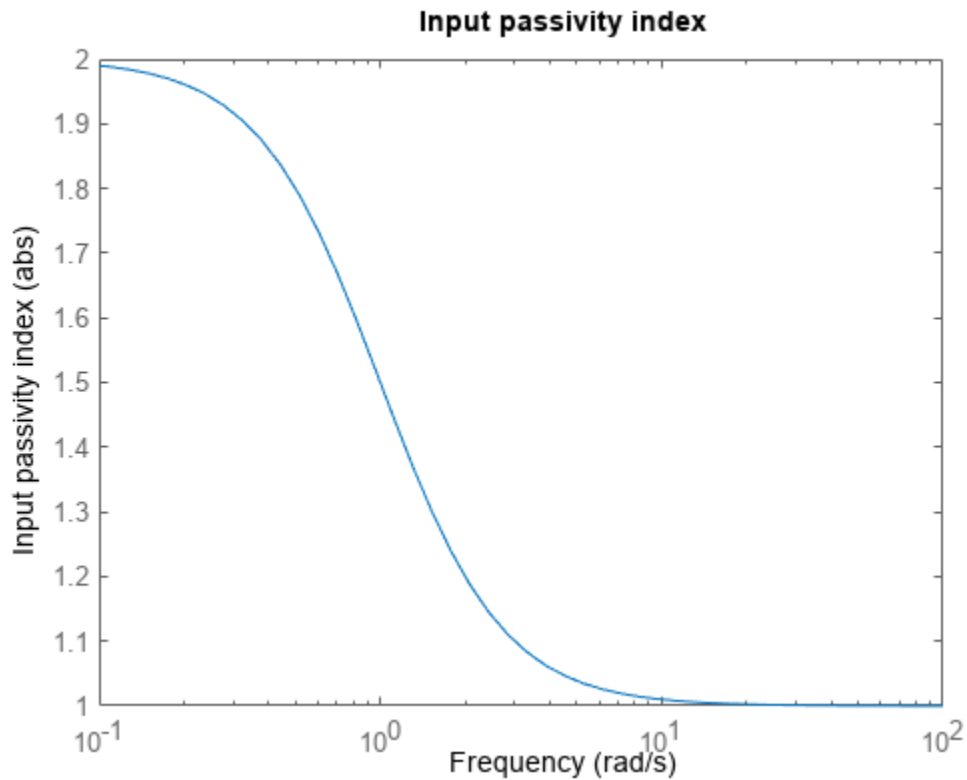

The input passivity index is positive at all frequencies. Therefore, the system is input strictly passive.

Plot Passivity of Multiple Systems

Plot the input passivity index of two dynamic systems and their series interconnection.

```
G1 = tf([5 3 1],[1 2 1]);
G2 = tf([1 1 5 0.1],[1 2 3 4]);
H = G2*G1;

passiveplot(G1,'r',G2,'b--',H,'gx','input')
legend('G1','G2','G2*G1')
```

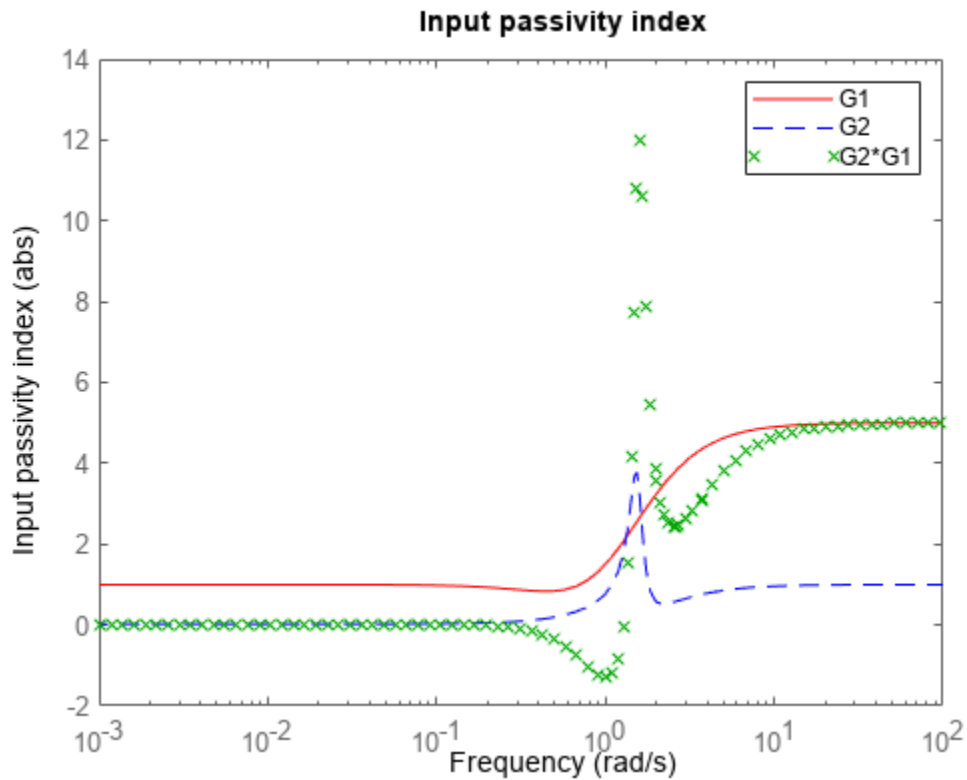

The input passivity index of the interconnected system dips below 0 around 1 rad/s. This plot shows that the series interconnection of two passive systems is not necessarily passive. However, passivity is preserved for parallel or feedback interconnections of passive systems.

Plot Passivity of Models with Complex Coefficients

Plot the relative passivity indices of a complex-coefficient model and a real-coefficient model on the same plot.

```
A = [-3.50, -1.25-0.25i; 2, 0];
B = [1; 0];
C = [-0.75-0.5i, 0.625-0.125i];
D = 0.5;
Gc = ss(A,B,C,D);
Gr = tf([1 5 10],[1 10 5]);
passiveplot(Gc,Gr)
legend('Complex-coefficient model','Real-coefficient model','Location','southeast')
```

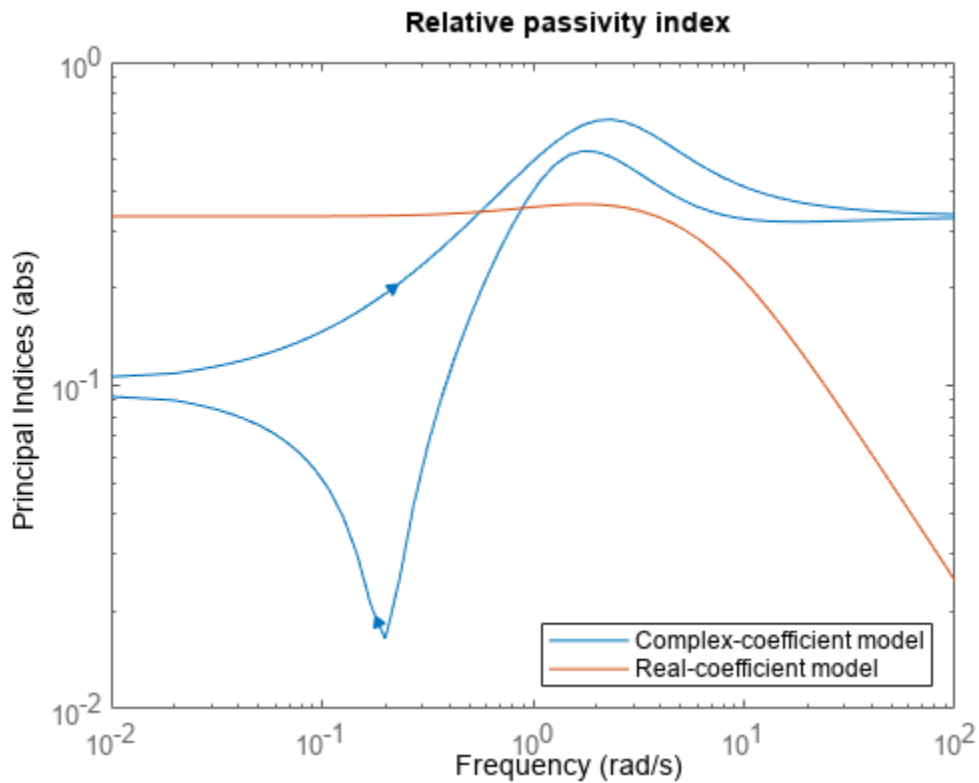

In log frequency scale, the plot shows two branches for models with complex coefficients, one for positive frequencies, with a right-pointing arrow, and one for negative frequencies, with a left-pointing arrow. In both branches, the arrows indicate the direction of increasing frequencies. The plots for models with real coefficients always contain a single branch with no arrows.

Set the plotting frequency scale to linear.

```
opt = sectorplotoptions;
opt.FreqScale = 'Linear';
```

Plot the indices.

```
passiveplot(Gc,Gr,opt)
legend('Complex-coefficient model','Real-coefficient model')
```

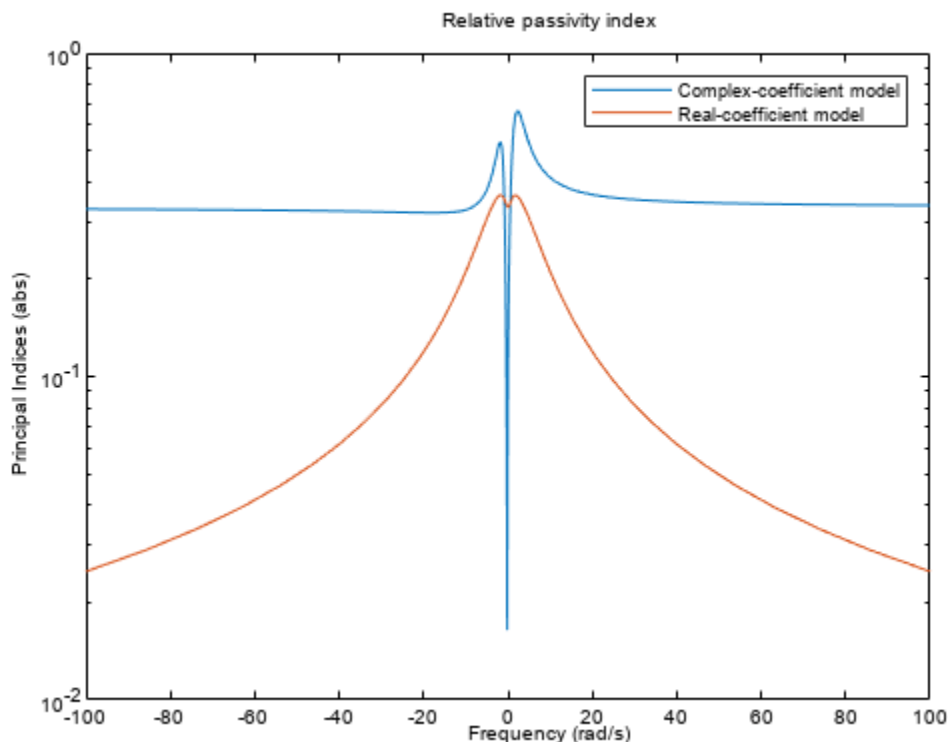

In linear frequency scale, the plots show a single branch with a symmetric frequency range centered at a frequency value of zero. The plot also shows the negative-frequency response of a real-coefficient model when you plot the response along with a complex-coefficient model.

Input Arguments

G — Model to analyze

dynamic system model | model array

Model to analyze for passivity, specified as a dynamic system model such as a `tf`, `ss`, or `genss` model. `G` can be MIMO, if the number of inputs equals the number of outputs. `G` can be continuous or discrete. If `G` is a generalized model with tunable or uncertain blocks, `passiveplot` evaluates passivity of the current, nominal value of `G`.

If `G` is a model array, then `passiveplot` plots the passivity index of all models in the array on the same plot. When you use output arguments to get passivity data, `G` must be a single model.

type — Type of passivity index

'input' | 'output' | 'io'

Type of passivity index, specified as one of the following:

- 'input' — Input passivity index (input feedforward passivity). This value is the smallest eigenvalue of $(G(s) + G(s)^H)/2$, for $s = j\omega$ in continuous time, and $s = e_{j\omega}$ in discrete time.

- 'output' — Output passivity index (output feedback passivity). When G is minimum phase, this value is the smallest eigenvalue of $(G(s)^{-1} + G(s)^{-H})/2$, for $s = j\omega$ in continuous time, and $s = e_{j\omega}$ in discrete time.
- 'io' — Combined I/O passivity index. When $I + G$ is minimum phase, this value is the largest $\tau(\omega)$ such that:

$$G(s) + G(s)^H > 2\tau(\omega)(I + G(s)^H G(s)),$$

for $s = j\omega$ in continuous time, and $s = e_{j\omega}$ in discrete time.

See “About Passivity and Passivity Indices” for details about these indices.

w — Frequencies

{wmin,wmax} | vector

Frequencies at which to compute and plot indices, specified as the cell array {wmin,wmax} or as a vector of frequency values.

- If w is a cell array of the form {wmin,wmax}, then the function computes the index at frequencies ranging between wmin and wmax.
- If w is a vector of frequencies, then the function computes the index at each specified frequency. For example, use `logspace` to generate a row vector with logarithmically-spaced frequency values.

For models with complex coefficients, if you specify a frequency range of $[w_{\min}, w_{\max}]$ for your plot, then in:

- Log frequency scale, the plot frequency limits are set to $[w_{\min}, w_{\max}]$ and the plot shows two branches, one for positive frequencies $[w_{\min}, w_{\max}]$ and one for negative frequencies $[-w_{\max}, -w_{\min}]$.
- Linear frequency scale, the plot frequency limits are set to $[-w_{\max}, w_{\max}]$ and the plot shows a single branch with a symmetric frequency range centered at a frequency value of zero.

Specify frequencies in units of rad/TimeUnit, where TimeUnit is the TimeUnit property of the model.

LineStyle — Line style, marker, and color

character vector | string

Line style, marker, and color, specified as a string or vector of one, two, or three characters. The characters can appear in any order. You do not need to specify all three characteristics (line style, marker, and color). For example, if you omit the line style and specify the marker, then the plot shows only the marker and no line. For more information about configuring this argument, see the LineSpec input argument of the `plot` function.

Example: 'r--' specifies a red dashed line

Example: '*b' specifies blue asterisk markers

Example: 'y' specifies a yellow line

plotoptions — Passivity index plot options set

SectorPlotOptions object

Passivity index plot options set, specified as a SectorPlotOptions object. You can use this option set to customize the plot appearance. Use `sectorplotoptions` to create the option set. Settings

you specify in `plotoptions` overrides the preference settings in the MATLAB session in which you run `passiveplot`. Therefore, `plotoptions` is useful when you want to write a script to generate multiple plots that look the same regardless of the local preferences.

For the list of available options, see `sectorplotoptions`.

Output Arguments

index — Passivity indices

matrix

Passivity indices as a function of frequency, returned as a matrix. `index` contains whichever type of passivity index you specify, computed at the frequencies `w` if you supplied them, or `wout` if you did not. `index` has as many columns as there are values in `w` or `wout`, and

- One row, for the input, output, or combined i/o passivity indices.
- As many rows as `G` has inputs or outputs, for the relative passivity index.

For example, suppose that `G` is a 3-input, 3-output system, and `w` is a 1-by-30 vector of frequencies. Then the following syntax returns a 3-by-30 matrix `index`.

```
index = passiveplot(G,w);
```

The entry `index(:,k)` contains the relative passivity indices of `G`, in descending order, at the frequency `w(k)`.

wout — Frequencies

vector

Frequencies at which the indices are calculated, returned as a vector. The function automatically chooses the frequency range and number of points based on the dynamics of the model.

`wout` also contains negative frequency values for models with complex coefficients.

Version History

Introduced in R2016a

See Also

`isPassive` | `getPassiveIndex` | `getSectorIndex` | `sectorplot` | `sectorplotoptions`

Topics

“About Passivity and Passivity Indices”

permute

Rearrange array dimensions in model arrays

Syntax

```
newarray = permute(sysarray,order)
```

Description

`newarray = permute(sysarray,order)` rearranges the array dimensions of a model array so that the dimensions are in the specified order. The input and output dimensions of the model array are not counted as array dimensions for this operation.

Examples

Permute Model Array Dimensions

Create a 1-by-2-by-3 array of state-space models.

```
sysarr = rss(2,2,2,1,2,3);
```

Rearrange the model array so that the dimensions are 3-by-2-by-1.

```
newarr = permute(sysarr,[3 2 1]);  
size(newarr)
```

```
3x2 array of state-space models.  
Each model has 2 outputs, 2 inputs, and 2 states.
```

The input and output dimensions of the model array remain unchanged.

Input Arguments

sysarray — Model array to rearrange

model array

Model array to rearrange, specified as an array of input-output models such as numeric LTI models, generalized models, or identified LTI models.

order — Dimensions of rearranged model array

vector

Dimensions of rearranged model array, specified as a vector of positive integers. For example, to rearrange a model array into a 3-by-2 array, `order` is `[3 2]`.

Data Types: `double`

Output Arguments

newarray — Rearranged model array
model array

Rearranged model array, returned as an array of input-output models with the new dimensions as specified in order.

Version History

Introduced in R2013a

See Also

[ndims](#) | [size](#) | [reshape](#)

pid

PID controller in parallel form

Description

Use `pid` to create parallel-form proportional-integral-derivative (PID) controller model objects, or to convert dynamic system models to parallel PID controller form.

The `pid` controller model object can represent parallel-form PID controllers in continuous time or discrete time.

- Continuous time — $C = K_p + \frac{K_i}{s} + \frac{K_d s}{T_f s + 1}$
- Discrete time — $C = K_p + K_i IF(z) + \frac{K_d}{T_f + DF(z)}$

Here:

- K_p is the proportional gain.
- K_i is the integral gain.
- K_d is the derivative gain.
- T_f is the first-order derivative filter time constant.
- $IF(z)$ is the integrator method for computing integral in discrete-time controller.
- $DF(z)$ is the integrator method for computing derivative filter in discrete-time controller.

You can then combine this object with other components of a control architecture, such as the plant, actuators, and sensors to represent your control system. For more information, see “Control System Modeling with Model Objects”.

You can create a PID controller model object by either specifying the controller parameters directly, or by converting a model of another type (such as a transfer function model `tf`) to PID controller form.

You can also use `pid` to create generalized state-space (`genss`) models or uncertain state-space (`uss`) models.

Creation

You can obtain `pid` controller models in one of the following ways.

- Create a model using the `pid` function.
- Use `pidtune` function to tune PID controllers for a plant model. Specify a 1-DOF PID controller type in the `type` argument of the `pidtune` function to obtain a parallel-form PID controller. For example:

```
sys = zpk([], [-1 -1 -1], 1);
C = pidtune(sys, 'PID');
```

- Interactively tune PID controller for a plant model using:
 - The **Tune PID Controller** Live Editor task.
 - The **PID Tuner** app.

Syntax

```
C = pid(Kp,Ki,Kd,Tf)
C = pid(Kp,Ki,Kd,Tf,Ts)
```

```
C = pid(Kp)
C = pid(Kp,Ki)
C = pid(Kp,Ki,Kd)
```

```
C = pid( ____,Name,Value)
```

```
C = pid
```

```
C = pid(sys)
```

Description

`C = pid(Kp,Ki,Kd,Tf)` creates a continuous-time parallel-form PID controller model and sets the properties `Kp`, `Ki`, `Kd`, and `Tf`. The remaining properties have default values.

`C = pid(Kp,Ki,Kd,Tf,Ts)` creates a discrete-time PID controller model with sample time `Ts`.

`C = pid(Kp)` creates a continuous-time proportional (P) controller.

`C = pid(Kp,Ki)` creates a proportional and integral (PI) controller.

`C = pid(Kp,Ki,Kd)` creates a proportional, integral, and derivative (PID) controller.

`C = pid(____,Name,Value)` sets properties of the `pid` controller object specified using one or more `Name,Value` arguments for any of the previous input-argument combinations.

`C = pid` creates a controller object with default property values. To modify the property of the controller model, use dot notation.

`C = pid(sys)` converts the dynamic system model `sys` to a parallel-form `pid` controller object.

Input Arguments

sys — Proportional gain

dynamic system model | model array

Dynamic system, specified as a SISO dynamic system model or array of SISO dynamic system models. Dynamic systems that you can use include:

- Continuous-time or discrete-time numeric LTI models, such as `tf`, `zpk`, `ss`, or `pidstd` models.
- Generalized or uncertain LTI models such as `genss` or `uss` models. (Using uncertain models requires Robust Control Toolbox software.)

The resulting PID controller assumes

- current values of the tunable components for tunable control design blocks.
- nominal model values for uncertain control design blocks.
- Identified LTI models, such as `idtf`, `idss`, `idproc`, `idpoly`, and `idgrey` models. (Using identified models requires System Identification Toolbox software.)

Output Arguments

C — Parallel-form PID controller model

`pid` model object | `genss` model object | `uss` model object

PID controller model, returned as:

- A parallel-form PID controller (`pid`) model object, when all the gains have numeric values. When the gains are numeric arrays, `C` is an array of `pid` controller objects.
- A generalized state-space model (`genss`) object, when the numerator or denominator input arguments includes tunable parameters, such as `realp` parameters or generalized matrices (`genmat`).
- An uncertain state-space model (`uss`) object, when the numerator or denominator input arguments includes uncertain parameters. Using uncertain models requires Robust Control Toolbox software.

Properties

Kp — Proportional gain

1 (default) | scalar | vector | matrix | `realp` object

Proportional gain, specified as a real and finite value or a tunable object.

- To create a `pid` controller object, use a real and finite scalar value.
- To create an array of `pid` controller objects, use an array of real and finite values.
- To create a tunable controller model, use a tunable parameter (`realp`) or generalized matrix (`genmat`).
- To create a tunable gain-scheduled controller model, use a tunable surface created using `tunableSurface`.

Ki — Integral gain

0 (default) | scalar | vector | matrix | `realp` object

Integral gain, specified as a real and finite value or a tunable object.

- To create a `pid` controller object, use a real and finite scalar value.
- To create an array of `pid` controller objects, use an array of real and finite values.
- To create a tunable controller model, use a tunable parameter (`realp`) or generalized matrix (`genmat`).
- To create a tunable gain-scheduled controller model, use a tunable surface created using `tunableSurface`.

Kd — Derivative gain

0 (default) | scalar | vector | matrix | `realp` object

Derivative gain, specified as a real and finite value or a tunable object.

- To create a `pid` controller object, use a real and finite scalar value.
- To create an array of `pid` controller objects, use an array of real and finite values.
- To create a tunable controller model, use a tunable parameter (`realp`) or generalized matrix (`genmat`).
- To create a tunable gain-scheduled controller model, use a tunable surface created using `tunableSurface`.

Tf — Derivative filter time constant

0 (default) | scalar | vector | matrix | `realp` object

Time constant of the first-order derivative filter, specified as a real and finite value or a tunable object.

- To create a `pid` controller object, use a real and finite scalar value.
- To create an array of `pid` controller objects, use an array of real and finite values.
- To create a tunable controller model, use a tunable parameter (`realp`) or generalized matrix (`genmat`).
- To create a tunable gain-scheduled controller model, use a tunable surface created using `tunableSurface`.

IFormula — Method for computing integral in discrete-time controller

'ForwardEuler' (default) | 'BackwardEuler' | 'Trapezoidal'

Discrete integrator formula $IF(z)$ for the integrator of the discrete-time `pid` controller:

$$C = K_p + K_i IF(z) + \frac{K_d}{T_f + DF(z)}$$

Specify `IFormula` as one of the following:

- 'ForwardEuler' — $IF(z) = \frac{T_s}{z-1}$.

This formula is best for small sample time, where the Nyquist limit is large compared to the bandwidth of the controller. For larger sample time, the `ForwardEuler` formula can result in instability, even when discretizing a system that is stable in continuous time.

- 'BackwardEuler' — $IF(z) = \frac{T_s z}{z-1}$.

An advantage of the `BackwardEuler` formula is that discretizing a stable continuous-time system using this formula always yields a stable discrete-time result.

- 'Trapezoidal' — $IF(z) = \frac{T_s z + 1}{2(z-1)}$.

An advantage of the `Trapezoidal` formula is that discretizing a stable continuous-time system using this formula always yields a stable discrete-time result. Of all available integration formulas, the `Trapezoidal` formula yields the closest match between frequency-domain properties of the discretized system and the corresponding continuous-time system.

When C is a continuous-time controller, `IFormula` is ''.

DFormula — Method for computing derivative in discrete-time controller

'ForwardEuler' (default) | 'BackwardEuler' | 'Trapezoidal'

Discrete integrator formula $DF(z)$ for the derivative filter of the discrete-time pid controller:

$$C = K_p + K_i IF(z) + \frac{K_d}{T_f + DF(z)}.$$

Specify DFormula as one of the following:

- 'ForwardEuler' — $DF(z) = \frac{T_s}{z-1}$.

This formula is best for small sample time, where the Nyquist limit is large compared to the bandwidth of the controller. For larger sample time, the ForwardEuler formula can result in instability, even when discretizing a system that is stable in continuous time.

- 'BackwardEuler' — $DF(z) = \frac{T_s z}{z-1}$.

An advantage of the BackwardEuler formula is that discretizing a stable continuous-time system using this formula always yields a stable discrete-time result.

- 'Trapezoidal' — $DF(z) = \frac{T_s z + 1}{2(z-1)}$.

An advantage of the Trapezoidal formula is that discretizing a stable continuous-time system using this formula always yields a stable discrete-time result. Of all available integration formulas, the Trapezoidal formula yields the closest match between frequency-domain properties of the discretized system and the corresponding continuous-time system.

The Trapezoidal value for DFormula is not available for a pid controller with no derivative filter ($T_f = 0$).

When C is a continuous-time controller, DFormula is ''.

InputDelay — Input delay

0 (default)

This property is read-only.

Time delay on the system input. InputDelay is always 0 for a pid controller object.

OutputDelay — Output delay

0 (default)

This property is read-only.

Time delay on the system output. OutputDelay is always 0 for a pid controller object.

Ts — Sample time

0 (default) | positive scalar

Sample time, specified as:

- 0 for continuous-time systems.

- A positive scalar representing the sampling period of a discrete-time system. Specify `Ts` in the time unit specified by the `TimeUnit` property.

PID controller models do not support unspecified sample time (`Ts = -1`).

Note Changing `Ts` does not discretize or resample the model. To convert between continuous-time and discrete-time representations, use `c2d` and `d2c`. To change the sample time of a discrete-time system, use `d2d`.

The discrete integrator formulas of the discretized controller depend upon the `c2d` discretization method you use, as shown in this table.

c2d Discretization Method	IFormula	DFormula
'zoh'	ForwardEuler	ForwardEuler
'foh'	Trapezoidal	Trapezoidal
'tustin'	Trapezoidal	Trapezoidal
'impulse'	ForwardEuler	ForwardEuler
'matched'	ForwardEuler	ForwardEuler

For more information about `c2d` discretization methods, see `c2d`.

If you require different discrete integrator formulas, you can discretize the controller by directly setting `Ts`, `IFormula`, and `DFormula` to the desired values. However, this method does not compute new gain and filter-constant values for the discretized controller. Therefore, this method might yield a poorer match between the continuous-time and discrete-time PID controllers than using `c2d`.

TimeUnit — Time variable units

'seconds' (default) | 'nanoseconds' | 'microseconds' | 'milliseconds' | 'minutes' | 'hours' | 'days' | 'weeks' | 'months' | 'years' | ...

Time variable units, specified as one of the following:

- 'nanoseconds'
- 'microseconds'
- 'milliseconds'
- 'seconds'
- 'minutes'
- 'hours'
- 'days'
- 'weeks'
- 'months'
- 'years'

Changing `TimeUnit` has no effect on other properties, but changes the overall system behavior. Use `chgTimeUnit` to convert between time units without modifying system behavior.

InputName — Input channel names

'' (default) | character vector

Input channel name, specified as one of the following:

- A character vector.
- `''`, no name specified.

Alternatively, assign the name `error` to the input of a controller model `C` as follows.

```
C.InputName = 'error';
```

You can use the shorthand notation `u` to refer to the `InputName` property. For example, `C.u` is equivalent to `C.InputName`.

Use `InputName` to:

- Identify channels on model display and plots.
- Specify connection points when interconnecting models.

InputUnit — Input channel units

`''` (default) | character vector

Input channel units, specified as one of the following:

- A character vector.
- `''`, no units specified.

Use `InputUnit` to specify input signal units. `InputUnit` has no effect on system behavior.

For example, assign the concentration units `'mol/m^3'` to the input of a controller model `C` as follows.

```
C.InputUnit = 'mol/m^3';
```

InputGroup — Input channel groups

structure

Input channel groups. This property is not needed for PID controller models.

By default, `InputGroup` is a structure with no fields.

OutputName — Output channel names

`''` (default) | character vector

Output channel name, specified as one of the following:

- A character vector.
- `''`, no name specified.

For example, assign the name `'control'` to the output of a controller model `C` as follows.

```
C.OutputName = 'control';
```

You can also use the shorthand notation `y` to refer to the `OutputName` property. For example, `C.y` is equivalent to `C.OutputName`.

Use `OutputName` to:

- Identify channels on model display and plots.
- Specify connection points when interconnecting models.

OutputUnit — Output channel units

' ' (default) | character vector

Output channel units, specified as one of the following:

- A character vector.
- ' ', no units specified.

Use `OutputUnit` to specify output signal units. `OutputUnit` has no effect on system behavior.

For example, assign the unit 'volts' to the output of a controller model `C` as follows.

```
C.OutputUnit = 'volts';
```

OutputGroup — Output channel groups

structure

Output channel groups. This property is not needed for PID controller models.

By default, `OutputGroup` is a structure with no fields.

Notes — User-specified text

{ } (default) | character vector | cell array of character vectors

User-specified text that you want to associate with the system, specified as a character vector or cell array of character vectors. For example, 'System is MIMO'.

UserData — User-specified data

[] (default) | any MATLAB data type

User-specified data that you want to associate with the system, specified as any MATLAB data type.

Name — System name

' ' (default) | character vector

System name, specified as a character vector. For example, 'system_1'.

SamplingGrid — Sampling grid for model arrays

structure array

Sampling grid for model arrays, specified as a structure array.

Use `SamplingGrid` to track the variable values associated with each model in a model array, including identified linear time-invariant (IDLTI) model arrays.

Set the field names of the structure to the names of the sampling variables. Set the field values to the sampled variable values associated with each model in the array. All sampling variables must be numeric scalars, and all arrays of sampled values must match the dimensions of the model array.

For example, you can create an 11-by-1 array of linear models, `sysarr`, by taking snapshots of a linear time-varying system at times $t = 0:10$. The following code stores the time samples with the linear models.

```
sysarr.SamplingGrid = struct('time',0:10)
```

Similarly, you can create a 6-by-9 model array, *M*, by independently sampling two variables, *zeta* and *w*. The following code maps the (*zeta*,*w*) values to *M*.

```
[zeta,w] = ndgrid(<6 values of zeta>,<9 values of w>)
M.SamplingGrid = struct('zeta',zeta,'w',w)
```

When you display *M*, each entry in the array includes the corresponding *zeta* and *w* values.

M

```
M(:,:,1,1) [zeta=0.3, w=5] =
```

```
      25
-----
s^2 + 3 s + 25
```

```
M(:,:,2,1) [zeta=0.35, w=5] =
```

```
      25
-----
s^2 + 3.5 s + 25
```

...

For model arrays generated by linearizing a Simulink model at multiple parameter values or operating points, the software populates *SamplingGrid* automatically with the variable values that correspond to each entry in the array. For instance, the Simulink Control Design commands *linearize* and *sLinearizer* populate *SamplingGrid* automatically.

By default, *SamplingGrid* is a structure with no fields.

Object Functions

The following lists contain a representative subset of the functions you can use with *pid* models. In general, any function applicable to “Dynamic System Models” is applicable to a *pid* object.

Linear Analysis

<i>step</i>	Step response plot of dynamic system; step response data
<i>impulse</i>	Impulse response plot of dynamic system; impulse response data
<i>lsim</i>	Plot simulated time response of dynamic system to arbitrary inputs; simulated response data
<i>bode</i>	Bode plot of frequency response, or magnitude and phase data
<i>nyquist</i>	Nyquist plot of frequency response
<i>nichols</i>	Nichols chart of frequency response
<i>bandwidth</i>	Frequency response bandwidth

Stability Analysis

<i>pole</i>	Poles of dynamic system
<i>zero</i>	Zeros and gain of SISO dynamic system
<i>pzplot</i>	Pole-zero plot of dynamic system model with additional plot customization options

margin Gain margin, phase margin, and crossover frequencies

Model Transformation

zpk Zero-pole-gain model
 ss State-space model
 c2d Convert model from continuous to discrete time
 d2c Convert model from discrete to continuous time
 d2d Resample discrete-time model

Model Interconnection

feedback Feedback connection of multiple models
 connect Block diagram interconnections of dynamic systems
 series Series connection of two models
 parallel Parallel connection of two models

Controller Design

pidtune PID tuning algorithm for linear plant model
 rlocus Root locus plot of dynamic system
 piddata Access coefficients of parallel-form PID controller
 make2DOF Convert 1-DOF PID controller to 2-DOF controller
 pidTuner Open PID Tuner for PID tuning
 tunablePID Tunable PID controller

Examples

PDF Controller

Create a continuous-time controller with proportional and derivative gains and a filter on the derivative term. To do so, set the integral gain to zero. Set the other gains and the filter time constant to the desired values.

```
Kp = 1;
Ki = 0; % No integrator
Kd = 3;
Tf = 0.5;
C = pid(Kp,Ki,Kd,Tf)
```

C =

$$K_p + K_d * \frac{s}{T_f s + 1}$$

with Kp = 1, Kd = 3, Tf = 0.5

Continuous-time PDF controller in parallel form.

The display shows the controller type, formula, and parameter values, and verifies that the controller has no integrator term.

Discrete-Time PI Controller

Create a discrete-time PI controller with trapezoidal discretization formula.

To create a discrete-time PI controller, set the value of `Ts` and the discretization formula using `Name, Value` syntax.

```
C1 = pid(5,2.4, 'Ts', 0.1, 'IFormula', 'Trapezoidal')    % Ts = 0.1s
```

```
C1 =
```

$$K_p + K_i * \frac{T_s(z+1)}{2*(z-1)}$$

```
with Kp = 5, Ki = 2.4, Ts = 0.1
```

```
Sample time: 0.1 seconds
```

```
Discrete-time PI controller in parallel form.
```

Alternatively, you can create the same discrete-time controller by supplying `Ts` as the fifth input argument after all four PID parameters, `Kp`, `Ki`, `Kd`, and `Tf`. Since you only want a PI controller, set `Kd` and `Tf` to zero.

```
C2 = pid(5,2.4,0,0,0.1, 'IFormula', 'Trapezoidal')
```

```
C2 =
```

$$K_p + K_i * \frac{T_s(z+1)}{2*(z-1)}$$

```
with Kp = 5, Ki = 2.4, Ts = 0.1
```

```
Sample time: 0.1 seconds
```

```
Discrete-time PI controller in parallel form.
```

The display shows that `C1` and `C2` are the same.

PID Controller with Named Input and Output

When you create a PID controller, set the dynamic system properties `InputName` and `OutputName`. This is useful, for example, when you interconnect the PID controller with other dynamic system models using the `connect` command.

```
C = pid(1,2,3, 'InputName', 'e', 'OutputName', 'u')
```

```
C =
```

$$K_p + K_i * \frac{1}{s} + K_d * s$$

```
with Kp = 1, Ki = 2, Kd = 3
```

```
Continuous-time PID controller in parallel form.
```

The display does not show the input and output names for the PID controller, but you can examine the property values. For instance, verify the input name of the controller.

C.InputName

```
ans = 1x1 cell array
    {'e'}
```

Array of PID Controllers

Create a 2-by-3 grid of PI controllers with proportional gain ranging from 1-2 across the array rows and integral gain ranging from 5-9 across columns.

To build the array of PID controllers, start with arrays representing the gains.

```
Kp = [1 1 1;2 2 2];
Ki = [5:2:9;5:2:9];
```

When you pass these arrays to the `pid` command, the command returns the array.

```
pi_array = pid(Kp,Ki,'Ts',0.1,'IFormula','BackwardEuler');
size(pi_array)
```

```
2x3 array of PID controller.
Each PID has 1 output and 1 input.
```

Alternatively, use the `stack` command to build an array of PID controllers.

```
C = pid(1,5,0.1)           % PID controller
```

```
C =
```

$$Kp + Ki * \frac{1}{s} + Kd * s$$

with $Kp = 1$, $Ki = 5$, $Kd = 0.1$

Continuous-time PID controller in parallel form.

```
Cf = pid(1,5,0.1,0.5)    % PID controller with filter
```

```
Cf =
```

$$Kp + Ki * \frac{1}{s} + Kd * \frac{s}{Tf*s+1}$$

with $Kp = 1$, $Ki = 5$, $Kd = 0.1$, $Tf = 0.5$

Continuous-time PIDF controller in parallel form.

```
pid_array = stack(2,C,Cf); % stack along 2nd array dimension
```

These commands return a 1-by-2 array of controllers.

```
size(pid_array)
```

1x2 array of PID controller.
Each PID has 1 output and 1 input.

All PID controllers in an array must have the same sample time, discrete integrator formulas, and dynamic system properties such as `InputName` and `OutputName`.

Convert PID Controller from Standard to Parallel Form

Convert a standard form `pidstd` controller to parallel form.

Standard PID form expresses the controller actions in terms of an overall proportional gain K_p , integral and derivative time constants T_i and T_d , and filter divisor N . You can convert any standard-form controller to parallel form using the `pid` command. For example, consider the following standard-form controller.

```
Kp = 2;
Ti = 3;
Td = 4;
N = 50;
C_std = pidstd(Kp,Ti,Td,N)
```

```
C_std =
```

$$K_p * \left(1 + \frac{1}{T_i} * \frac{1}{s} + T_d * \frac{s}{(T_d/N)*s+1} \right)$$

with $K_p = 2$, $T_i = 3$, $T_d = 4$, $N = 50$

Continuous-time PIDF controller in standard form

Convert this controller to parallel form using `pid`.

```
C_par = pid(C_std)
```

```
C_par =
```

$$K_p + K_i * \frac{1}{s} + K_d * \frac{s}{T_f*s+1}$$

with $K_p = 2$, $K_i = 0.667$, $K_d = 8$, $T_f = 0.08$

Continuous-time PIDF controller in parallel form.

Convert Dynamic System to Parallel-Form PID Controller

Convert a continuous-time dynamic system that represents a PID controller to parallel `pid` form.

The following dynamic system, with an integrator and two zeros, is equivalent to a PID controller.

$$H(s) = \frac{3(s+1)(s+2)}{s}$$

Create a zpk model of H . Then use the `pid` command to obtain H in terms of the PID gains K_p , K_i , and K_d .

```
H = zpk([-1, -2], 0, 3);
C = pid(H)
```

C =

$$K_p + K_i * \frac{1}{s} + K_d * s$$

with $K_p = 9$, $K_i = 6$, $K_d = 3$

Continuous-time PID controller in parallel form.

Convert Discrete-Time Dynamic System to Parallel-Form PID Controller

Convert a discrete-time dynamic system that represents a PID controller with derivative filter to parallel `pid` form.

Create a discrete-time zpk model that represents a PIDF controller (two zeros and two poles, including the integrator pole at $z = 1$).

```
sys = zpk([-0.5, -0.6], [1 -0.2], 3, 'Ts', 0.1);
```

When you convert `sys` to PID form, the result depends on which discrete integrator formulas you specify for the conversion. For instance, use the default, `ForwardEuler`, for both the integrator and the derivative.

```
Cfe = pid(sys)
```

Cfe =

$$K_p + K_i * \frac{T_s}{z-1} + K_d * \frac{1}{T_f + T_s / (z-1)}$$

with $K_p = 2.75$, $K_i = 60$, $K_d = 0.0208$, $T_f = 0.0833$, $T_s = 0.1$

Sample time: 0.1 seconds

Discrete-time PIDF controller in parallel form.

Now convert using the Trapezoidal formula.

```
Ctrap = pid(sys, 'IFormula', 'Trapezoidal', 'DFormula', 'Trapezoidal')
```

Ctrap =

$$K_p + K_i * \frac{T_s * (z+1)}{2 * (z-1)} + K_d * \frac{1}{T_f + T_s / 2 * (z+1) / (z-1)}$$

```
with Kp = -0.25, Ki = 60, Kd = 0.0208, Tf = 0.0333, Ts = 0.1
```

```
Sample time: 0.1 seconds
Discrete-time PIDF controller in parallel form.
```

The displays show the difference in resulting coefficient values and functional form.

For this particular dynamic system, you cannot write `sys` in parallel PID form using the `BackwardEuler` formula for the derivative filter. Doing so would result in $Tf < 0$, which is not permitted. In that case, `pid` returns an error.

Discretize Continuous-Time PID Controller

Discretize a continuous-time PID controller and set integral and derivative filter formulas.

Create a continuous-time controller and discretize it using the zero-order-hold method of the `c2d` command.

```
Ccon = pid(1,2,3,4); % continuous-time PIDF controller
Cdis1 = c2d(Ccon,0.1,'zoh')
```

```
Cdis1 =
```

$$Kp + Ki * \frac{T_s}{z-1} + Kd * \frac{1}{Tf+Ts/(z-1)}$$

```
with Kp = 1, Ki = 2, Kd = 3.04, Tf = 4.05, Ts = 0.1
```

```
Sample time: 0.1 seconds
Discrete-time PIDF controller in parallel form.
```

The display shows that `c2d` computes new PID gains for the discrete-time controller.

The discrete integrator formulas of the discretized controller depend on the `c2d` discretization method. For the `zoh` method, both `IFormula` and `DFormula` are `ForwardEuler`.

```
Cdis1.IFormula
```

```
ans =
'ForwardEuler'
```

```
Cdis1.DFormula
```

```
ans =
'ForwardEuler'
```

If you want to use different formulas from the ones returned by `c2d`, then you can directly set the `Ts`, `IFormula`, and `DFormula` properties of the controller to the desired values.

```
Cdis2 = Ccon;
Cdis2.Ts = 0.1;
Cdis2.IFormula = 'BackwardEuler';
Cdis2.DFormula = 'BackwardEuler';
```

However, these commands do not compute new PID gains for the discretized controller. To see this, examine `Cdis2` and compare the coefficients to `Ccon` and `Cdis1`.

`Cdis2`

`Cdis2 =`

$$K_p + K_i * \frac{T_s * z}{z - 1} + K_d * \frac{1}{T_f + T_s * z / (z - 1)}$$

with $K_p = 1$, $K_i = 2$, $K_d = 3$, $T_f = 4$, $T_s = 0.1$

Sample time: 0.1 seconds

Discrete-time PIDF controller in parallel form.

Version History

Introduced in R2010b

See Also

`pidstd` | `pid2` | `piddata` | `make2DOF` | `pidtune` | `pidTuner` | `tunablePID` | `genss` | `realp`

Topics

"Proportional-Integral-Derivative (PID) Controllers"

"Discrete-Time Proportional-Integral-Derivative (PID) Controllers"

"What Are Model Objects?"

pid2

Create 2-DOF PID controller in parallel form, convert to parallel-form 2-DOF PID controller

Syntax

```
C2 = pid2(Kp,Ki,Kd,Tf,b,c)
C2 = pid2(Kp,Ki,Kd,Tf,b,c,Ts)
C2 = pid2(sys)
C2 = pid2( ___,Name,Value)
```

Description

`pid2` controller objects represent two-degree-of-freedom (2-DOF) PID controllers in parallel form. Use `pid2` either to create a `pid2` controller object from known coefficients or to convert a dynamic system model to a `pid2` object.

Two-degree-of-freedom (2-DOF) PID controllers include setpoint weighting on the proportional and derivative terms. A 2-DOF PID controller can achieve fast disturbance rejection without significant increase of overshoot in setpoint tracking. 2-DOF PID controllers are also useful to mitigate the influence of changes in the reference signal on the control signal. The following illustration shows a typical control architecture using a 2-DOF PID controller.

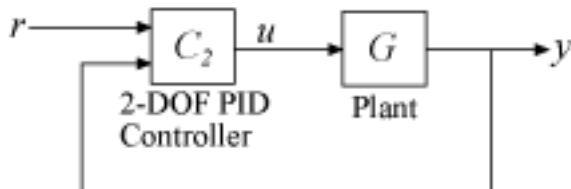

`C2 = pid2(Kp,Ki,Kd,Tf,b,c)` creates a continuous-time 2-DOF PID controller with proportional, integral, and derivative gains K_p , K_i , and K_d and first-order derivative filter time constant T_f . The controller also has setpoint weighting b on the proportional term, and setpoint weighting c on the derivative term. The relationship between the 2-DOF controller output (u) and its two inputs (r and y) is given by:

$$u = K_p(br - y) + \frac{K_i}{s}(r - y) + \frac{K_d s}{T_f s + 1}(cr - y).$$

This representation is in parallel form. If all coefficients are real-valued, then the resulting `C2` is a `pid2` controller object. If one or more of these coefficients is tunable (`realp` or `genmat`), then `C2` is a tunable generalized state-space (`genss`) model object.

`C2 = pid2(Kp,Ki,Kd,Tf,b,c,Ts)` creates a discrete-time 2-DOF PID controller with sample time T_s . The relationship between the controller output and inputs is given by:

$$u = K_p(br - y) + K_i IF(z)(r - y) + \frac{K_d}{T_f + DF(z)}(cr - y).$$

$IF(z)$ and $DF(z)$ are the discrete integrator formulas for the integrator and derivative filter. By default,

$$IF(z) = DF(z) = \frac{T_s}{z-1}.$$

To choose different discrete integrator formulas, use the `IFormula` and `DFormula` properties. (See “Properties” on page 2-917 for more information). If `DFormula` = 'ForwardEuler' (the default value) and `Tf` \neq 0, then `Ts` and `Tf` must satisfy `Tf` > `Ts`/2. This requirement ensures a stable derivative filter pole.

`C2 = pid2(sys)` converts the dynamic system `sys` to a parallel form `pid2` controller object.

`C2 = pid2(____, Name, Value)` specifies additional properties as comma-separated pairs of `Name, Value` arguments.

Input Arguments

Kp

Proportional gain.

`Kp` can be:

- A real and finite value.
- An array of real and finite values.
- A tunable parameter (`realp`) or generalized matrix (`genmat`).
- A tunable surface for gain-scheduled tuning, created using `tunableSurface`.

When `Kp` = 0, the controller has no proportional action.

Default: 1

Ki

Integral gain.

`Ki` can be:

- A real and finite value.
- An array of real and finite values.
- A tunable parameter (`realp`) or generalized matrix (`genmat`).
- A tunable surface for gain-scheduled tuning, created using `tunableSurface`.

When `Ki` = 0, the controller has no integral action.

Default: 0

Kd

Derivative gain.

`Kd` can be:

- A real and finite value.
- An array of real and finite values.
- A tunable parameter (`realp`) or generalized matrix (`genmat`).
- A tunable surface for gain-scheduled tuning, created using `tunableSurface`.

When $K_d = 0$, the controller has no derivative action.

Default: 0

Tf

Time constant of the first-order derivative filter.

Tf can be:

- A real, finite, and nonnegative value.
- An array of real, finite, and nonnegative values.
- A tunable parameter (`realp`) or generalized matrix (`genmat`).
- A tunable surface for gain-scheduled tuning, created using `tunableSurface`.

When $T_f = 0$, the controller has no filter on the derivative action.

Default: 0

b

Setpoint weighting on proportional term.

b can be:

- A real, nonnegative, and finite value.
- An array of real, nonnegative, finite values.
- A tunable parameter (`realp`) or generalized matrix (`genmat`).
- A tunable surface for gain-scheduled tuning, created using `tunableSurface`.

When $b = 0$, changes in setpoint do not feed directly into the proportional term.

Default: 1

c

Setpoint weighting on derivative term.

c can be:

- A real, nonnegative, and finite value.
- An array of real, nonnegative, finite values.
- A tunable parameter (`realp`) or generalized matrix (`genmat`).
- A tunable surface for gain-scheduled tuning, created using `tunableSurface`.

When $c = 0$, changes in setpoint do not feed directly into the derivative term.

Default: 1

Ts

Sample time.

To create a discrete-time `pid2` controller, provide a positive real value ($T_s > 0$). `pid2` does not support discrete-time controllers with unspecified sample time ($T_s = -1$).

T_s must be a scalar value. In an array of `pid2` controllers, each controller must have the same T_s .

Default: 0 (continuous time)

sys

SISO dynamic system to convert to parallel `pid2` form.

`sys` must be a two-input, one-output system. `sys` must represent a valid 2-DOF PID controller that can be written in parallel form with $T_f \geq 0$.

`sys` can also be an array of SISO dynamic systems.

Name-Value Pair Arguments

Specify optional comma-separated pairs of `Name`, `Value` arguments. `Name` is the argument name and `Value` is the corresponding value. `Name` must appear inside quotes. You can specify several name and value pair arguments in any order as `Name1, Value1, . . . , NameN, ValueN`.

Use `Name, Value` syntax to set the numerical integration formulas `IFormula` and `DFormula` of a discrete-time `pid2` controller, or to set other object properties such as `InputName` and `OutputName`. For information about available properties of `pid2` controller objects, see “Properties” on page 2-917.

Output Arguments

C2

2-DOF PID controller, returned as a `pid2` controller object, an array of `pid2` controller objects, a `genss` object, or a `genss` array.

- If all the coefficients have scalar numeric values, then `C2` is a `pid2` controller object.
- If one or more coefficients is a numeric array, `C2` is an array of `pid2` controller objects. The controller type (such as PI, PID, or PDF) depends upon the values of the gains. For example, when $K_d = 0$, but K_p and K_i are nonzero, `C2` is a PI controller.
- If one or more coefficients is a tunable parameter (`realp`), generalized matrix (`genmat`), or tunable gain surface (`tunableSurface`), then `C2` is a generalized state-space model (`genss`).

Properties

b, c

Setpoint weights on the proportional and derivative terms, respectively. `b` and `c` values are real, finite, and positive. When you use the `pid2` command to create a 2-DOF PID controller, the `b`, and `c` input arguments, respectively, set the initial values of these properties.

Kp, Ki, Kd

PID controller gains.

Proportional, integral, and derivative gains, respectively. `Kp`, `Ki`, and `Kd` values are real and finite. When you use the `pid2` command to create a 2-DOF PID controller, the `Kp`, `Ki`, and `Kd` input arguments, respectively, set the initial values of these properties.

Tf

Derivative filter time constant.

The `Tf` property stores the derivative filter time constant of the `pid2` controller object. `Tf` is real, finite, and greater than or equal to zero. When you create a 2-DOF PID controller using the `pid2` command, the `Tf` input argument sets the initial value of this property.

IFormula

Discrete integrator formula $IF(z)$ for the integrator of the discrete-time `pid2` controller `C2`. The relationship between the inputs and output of `C2` is given by:

$$u = K_p(br - y) + K_i IF(z)(r - y) + \frac{K_d}{T_f + DF(z)}(cr - y).$$

`IFormula` can take the following values:

- 'ForwardEuler' — $IF(z) = \frac{T_s}{z - 1}$.

This formula is best for small sample time, where the Nyquist limit is large compared to the bandwidth of the controller. For larger sample time, the `ForwardEuler` formula can result in instability, even when discretizing a system that is stable in continuous time.

- 'BackwardEuler' — $IF(z) = \frac{T_s z}{z - 1}$.

An advantage of the `BackwardEuler` formula is that discretizing a stable continuous-time system using this formula always yields a stable discrete-time result.

- 'Trapezoidal' — $IF(z) = \frac{T_s z + 1}{2(z - 1)}$.

An advantage of the `Trapezoidal` formula is that discretizing a stable continuous-time system using this formula always yields a stable discrete-time result. Of all available integration formulas, the `Trapezoidal` formula yields the closest match between frequency-domain properties of the discretized system and the corresponding continuous-time system.

When `C2` is a continuous-time controller, `IFormula` is `' '`.

Default: 'ForwardEuler'

DFormula

Discrete integrator formula $DF(z)$ for the derivative filter of the discrete-time `pid2` controller `C2`. The relationship between the inputs and output of `C2` is given by:

$$u = K_p(br - y) + K_i F(z)(r - y) + \frac{K_d}{T_f + DF(z)}(cr - y).$$

DFormula can take the following values:

- 'ForwardEuler' — $DF(z) = \frac{T_s}{z - 1}$.

This formula is best for small sample time, where the Nyquist limit is large compared to the bandwidth of the controller. For larger sample time, the ForwardEuler formula can result in instability, even when discretizing a system that is stable in continuous time.

- 'BackwardEuler' — $DF(z) = \frac{T_s z}{z - 1}$.

An advantage of the BackwardEuler formula is that discretizing a stable continuous-time system using this formula always yields a stable discrete-time result.

- 'Trapezoidal' — $DF(z) = \frac{T_s z + 1}{2(z - 1)}$.

An advantage of the Trapezoidal formula is that discretizing a stable continuous-time system using this formula always yields a stable discrete-time result. Of all available integration formulas, the Trapezoidal formula yields the closest match between frequency-domain properties of the discretized system and the corresponding continuous-time system.

The Trapezoidal value for DFormula is not available for a pid2 controller with no derivative filter ($T_f = 0$).

When C2 is a continuous-time controller, DFormula is ' '.

Default: 'ForwardEuler'

InputDelay

Time delay on the system input. InputDelay is always 0 for a pid2 controller object.

OutputDelay

Time delay on the system Output. OutputDelay is always 0 for a pid2 controller object.

Ts

Sample time. For continuous-time models, $T_s = 0$. For discrete-time models, T_s is a positive scalar representing the sampling period. This value is expressed in the unit specified by the TimeUnit property of the model. PID controller models do not support unspecified sample time ($T_s = -1$).

Changing this property does not discretize or resample the model. Use c2d and d2c to convert between continuous- and discrete-time representations. Use d2d to change the sample time of a discrete-time system.

Default: 0 (continuous time)

TimeUnit

Units for the time variable, the sample time T_s , and any time delays in the model, specified as one of the following values:

- 'nanoseconds'
- 'microseconds'
- 'milliseconds'
- 'seconds'
- 'minutes'
- 'hours'
- 'days'
- 'weeks'
- 'months'
- 'years'

Changing this property has no effect on other properties, and therefore changes the overall system behavior. Use `chgTimeUnit` to convert between time units without modifying system behavior.

Default: 'seconds'

InputName

Input channel name, specified as a character vector or a 2-by-1 cell array of character vectors. Use this property to name the input channels of the controller model. For example, assign the names `setpoint` and `measurement` to the inputs of a 2-DOF PID controller model `C` as follows.

```
C.InputName = {'setpoint'; 'measurement'};
```

Alternatively, use automatic vector expansion to assign both input names. For example:

```
C.InputName = 'C-input';
```

The input names automatically expand to `{'C-input(1)'; 'C-input(2)'}`.

You can use the shorthand notation `u` to refer to the `InputName` property. For example, `C.u` is equivalent to `C.InputName`.

Input channel names have several uses, including:

- Identifying channels on model display and plots
- Specifying connection points when interconnecting models

Default: {''; ''}

InputUnit

Input channel units, specified as a 2-by-1 cell array of character vectors. Use this property to track input signal units. For example, assign the units `Volts` to the reference input and the concentration units `mol/m^3` to the measurement input of a 2-DOF PID controller model `C` as follows.

```
C.InputUnit = {'Volts'; 'mol/m^3'};
```

`InputUnit` has no effect on system behavior.

Default: {''; ''}

InputGroup

Input channel groups. This property is not needed for PID controller models.

Default: struct with no fields

OutputName

Output channel name, specified as a character vector. Use this property to name the output channel of the controller model. For example, assign the name `control` to the output of a controller model `C` as follows.

```
C.OutputName = 'control';
```

You can use the shorthand notation `y` to refer to the `OutputName` property. For example, `C.y` is equivalent to `C.OutputName`.

Input channel names have several uses, including:

- Identifying channels on model display and plots
- Specifying connection points when interconnecting models

Default: Empty character vector, ''

OutputUnit

Output channel units, specified as a character vector. Use this property to track output signal units. For example, assign the unit `Volts` to the output of a controller model `C` as follows.

```
C.OutputUnit = 'Volts';
```

`OutputUnit` has no effect on system behavior.

Default: Empty character vector, ''

OutputGroup

Output channel groups. This property is not needed for PID controller models.

Default: struct with no fields

Name

System name, specified as a character vector. For example, `'system_1'`.

Default: ''

Notes

Any text that you want to associate with the system, stored as a string or a cell array of character vectors. The property stores whichever data type you provide. For instance, if `sys1` and `sys2` are dynamic system models, you can set their `Notes` properties as follows:

```
sys1.Notes = "sys1 has a string.";
sys2.Notes = 'sys2 has a character vector.';
sys1.Notes
sys2.Notes
```

```
ans =  
    "sys1 has a string."  
  
ans =  
    'sys2 has a character vector.'
```

Default: [0×1 string]

UserData

Any type of data you want to associate with system, specified as any MATLAB data type.

Default: []

SamplingGrid

Sampling grid for model arrays, specified as a data structure.

For model arrays that are derived by sampling one or more independent variables, this property tracks the variable values associated with each model in the array. This information appears when you display or plot the model array. Use this information to trace results back to the independent variables.

Set the field names of the data structure to the names of the sampling variables. Set the field values to the sampled variable values associated with each model in the array. All sampling variables should be numeric and scalar valued, and all arrays of sampled values should match the dimensions of the model array.

For example, suppose you create a 11-by-1 array of linear models, `sysarr`, by taking snapshots of a linear time-varying system at times `t = 0:10`. The following code stores the time samples with the linear models.

```
sysarr.SamplingGrid = struct('time',0:10)
```

Similarly, suppose you create a 6-by-9 model array, `M`, by independently sampling two variables, `zeta` and `w`. The following code attaches the (`zeta,w`) values to `M`.

```
[zeta,w] = ndgrid(<6 values of zeta>,<9 values of w>)  
M.SamplingGrid = struct('zeta',zeta,'w',w)
```

When you display `M`, each entry in the array includes the corresponding `zeta` and `w` values.

`M`

```
M(:,:,1,1) [zeta=0.3, w=5] =
```

```
      25  
-----  
s^2 + 3 s + 25
```

```
M(:,:,2,1) [zeta=0.35, w=5] =
```

```

          25
-----
s^2 + 3.5 s + 25
...

```

For model arrays generated by linearizing a Simulink model at multiple parameter values or operating points, the software populates `SamplingGrid` automatically with the variable values that correspond to each entry in the array. For example, the Simulink Control Design commands `linearize` and `sLinearizer` populate `SamplingGrid` in this way.

Default: []

Examples

2-DOF PDF Controller

Create a continuous-time 2-DOF controller with proportional and derivative gains and a filter on the derivative term. To do so, set the integral gain to zero. Set the other gains and the filter time constant to the desired values.

```

Kp = 1;
Ki = 0;    % No integrator
Kd = 3;
Tf = 0.1;
b = 0.5;   % setpoint weight on proportional term
c = 0.5;   % setpoint weight on derivative term
C2 = pid2(Kp,Ki,Kd,Tf,b,c)

```

C2 =

$$u = K_p (b*r-y) + K_d \frac{s}{T_f*s+1} (c*r-y)$$

with $K_p = 1$, $K_d = 3$, $T_f = 0.1$, $b = 0.5$, $c = 0.5$

Continuous-time 2-DOF PDF controller in parallel form.

The display shows the controller type, formula, and parameter values, and verifies that the controller has no integrator term.

Discrete-Time 2-DOF PI Controller

Create a discrete-time 2-DOF PI controller using the trapezoidal discretization formula. Specify the formula using `Name, Value` syntax.

```

Kp = 5;
Ki = 2.4;
Kd = 0;
Tf = 0;
b = 0.5;

```

```

c = 0;
Ts = 0.1;
C2 = pid2(Kp,Ki,Kd,Tf,b,c,Ts,'IFormula','Trapezoidal')
C2 =

```

$$u = K_p (b*r-y) + K_i \frac{T_s*(z+1)}{2*(z-1)} (r-y)$$

with $K_p = 5$, $K_i = 2.4$, $b = 0.5$, $T_s = 0.1$

Sample time: 0.1 seconds
 Discrete-time 2-DOF PI controller in parallel form.

Setting $K_d = 0$ specifies a PI controller with no derivative term. As the display shows, the values of T_f and c are not used in this controller. The display also shows that the trapezoidal formula is used for the integrator.

2-DOF PID Controller with Named Inputs and Output

Create a 2-DOF PID controller, and set the dynamic system properties `InputName` and `OutputName`. Naming the inputs and the output is useful, for example, when you interconnect the PID controller with other dynamic system models using the `connect` command.

```

C2 = pid2(1,2,3,0,1,1,'InputName',{'r','y'},'OutputName','u')

```

```

C2 =

```

$$u = K_p (b*r-y) + K_i \frac{1}{s} (r-y) + K_d*s (c*r-y)$$

with $K_p = 1$, $K_i = 2$, $K_d = 3$, $b = 1$, $c = 1$

Continuous-time 2-DOF PID controller in parallel form.

A 2-DOF PID controller has two inputs and one output. Therefore, the `'InputName'` property is an array containing two names, one for each input. The model display does not show the input and output names for the PID controller, but you can examine the property values to see them. For instance, verify the input name of the controller.

```

C2.InputName

```

```

ans = 2x1 cell
    {'r'}
    {'y'}

```

Array of 2-DOF PID Controllers

Create a 2-by-3 grid of 2-DOF PI controllers with proportional gain ranging from 1-2 across the array rows and integral gain ranging from 5-9 across columns.

To build the array of PID controllers, start with arrays representing the gains.

```
Kp = [1 1 1;2 2 2];
Ki = [5:2:9;5:2:9];
```

When you pass these arrays to the `pid2` command, the command returns the array of controllers.

```
pi_array = pid2(Kp,Ki,0,0,0.5,0,'Ts',0.1,'IFormula','BackwardEuler');
size(pi_array)
```

```
2x3 array of 2-DOF PID controller.
Each PID has 1 output and 2 inputs.
```

If you provide scalar values for some coefficients, `pid2` automatically expands them and assigns the same value to all entries in the array. For instance, in this example, $K_d = T_f = 0$, so that all entries in the array are PI controllers. Also, all entries in the array have $b = 0.5$.

Access entries in the array using array indexing. For dynamic system arrays, the first two dimensions are the I/O dimensions of the model, and the remaining dimensions are the array dimensions. Therefore, the following command extracts the (2,3) entry in the array.

```
pi23 = pi_array(:, :, 2, 3)
```

```
pi23 =
```

$$u = K_p (b*r-y) + K_i \frac{T_s*z}{z-1} (r-y)$$

```
with Kp = 2, Ki = 9, b = 0.5, Ts = 0.1
```

```
Sample time: 0.1 seconds
Discrete-time 2-DOF PI controller in parallel form.
```

You can also build an array of PID controllers using the `stack` command.

```
C2 = pid2(1,5,0.1,0,0.5,0.5);           % PID controller
C2f = pid2(1,5,0.1,0.5,0.5,0.5);       % PID controller with filter
pid_array = stack(2,C2,C2f);           % stack along 2nd array dimension
```

These commands return a 1-by-2 array of controllers.

```
size(pid_array)
```

```
1x2 array of 2-DOF PID controller.
Each PID has 1 output and 2 inputs.
```

All PID controllers in an array must have the same sample time, discrete integrator formulas, and dynamic system properties such as `InputName` and `OutputName`.

Convert 2-DOF PID Controller from Standard to Parallel Form

Convert a standard-form `pidstd2` controller to parallel form.

Standard PID form expresses the controller actions in terms of an overall proportional gain K_p , integrator and derivative time constants T_i and T_d , and filter divisor N . You can convert any 2-DOF

standard-form controller to parallel form using the `pid2` command. For example, consider the following standard-form controller.

```
Kp = 2;
Ti = 3;
Td = 4;
N = 50;
b = 0.1;
c = 0.5;
C2_std = pidstd2(Kp,Ti,Td,N,b,c)
```

C2_std =

$$u = K_p * [(b*r-y) + \frac{1}{T_i} * \frac{1}{s} * (r-y) + T_d * \frac{s}{(T_d/N)*s+1} * (c*r-y)]$$

with $K_p = 2$, $T_i = 3$, $T_d = 4$, $N = 50$, $b = 0.1$, $c = 0.5$

Continuous-time 2-DOF PIDF controller in standard form

Convert this controller to parallel form using `pid2`.

```
C2_par = pid2(C2_std)
```

C2_par =

$$u = K_p (b*r-y) + K_i \frac{1}{s} (r-y) + K_d \frac{s}{T_f*s+1} (c*r-y)$$

with $K_p = 2$, $K_i = 0.667$, $K_d = 8$, $T_f = 0.08$, $b = 0.1$, $c = 0.5$

Continuous-time 2-DOF PIDF controller in parallel form.

A response plot confirms that the two forms are equivalent.

```
bodeplot(C2_par,'b-',C2_std,'r--')
legend('Parallel','Standard','Location','Southeall')
```

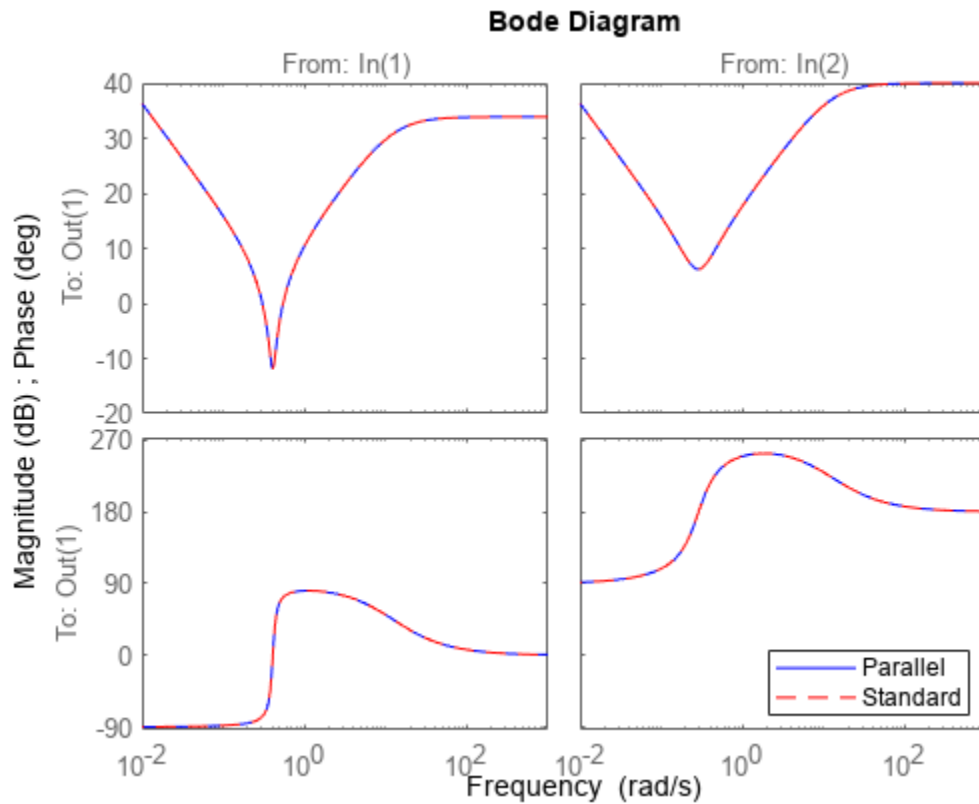
Convert Dynamic System to Parallel-Form PID Controller

Convert a continuous-time dynamic system that represents a PID controller to parallel pid form.

The following dynamic system, with an integrator and two zeros, is equivalent to a PID controller.

$$H(s) = \frac{3(s+1)(s+2)}{s}$$

Create a zpk model of H . Then use the `pid` command to obtain H in terms of the PID gains K_p , K_i , and K_d .

```
H = zpk([-1, -2], 0, 3);
C = pid(H)
```

```
C =
```

$$K_p + K_i * \frac{1}{s} + K_d * s$$

```
with Kp = 9, Ki = 6, Kd = 3
```

Continuous-time PID controller in parallel form.

Convert Dynamic System to 2-DOF Parallel-Form PID Controller

Convert a discrete-time dynamic system that represents a 2-DOF PID controller with derivative filter to parallel pid2 form.

The following state-space matrices represent a discrete-time 2-DOF PID controller with a sample time of 0.1 s.

```
A = [1,0;0,0.99];
B = [0.1,-0.1; -0.005,0.01];
C = [3,0.2];
D = [2.6,-5.2];
Ts = 0.1;
sys = ss(A,B,C,D,Ts);
```

When you convert `sys` to 2-DOF PID form, the result depends on which discrete integrator formulas you specify for the conversion. For instance, use the default, `ForwardEuler`, for both the integrator and the derivative.

```
C2fe = pid2(sys)
```

```
C2fe =
```

$$u = K_p (b*r-y) + K_i \frac{T_s}{z-1} (r-y) + K_d \frac{1}{T_f+T_s/(z-1)} (c*r-y)$$

with $K_p = 5$, $K_i = 3$, $K_d = 2$, $T_f = 10$, $b = 0.5$, $c = 0.5$, $T_s = 0.1$

Sample time: 0.1 seconds

Discrete-time 2-DOF PIDF controller in parallel form.

Now convert using the Trapezoidal formula.

```
C2trap = pid2(sys,'IFormula','Trapezoidal','DFormula','Trapezoidal')
```

```
C2trap =
```

$$u = K_p (b*r-y) + K_i \frac{T_s*(z+1)}{2*(z-1)} (r-y) + K_d \frac{1}{T_f+T_s/2*(z+1)/(z-1)} (c*r-y)$$

with $K_p = 4.85$, $K_i = 3$, $K_d = 2$, $T_f = 9.95$, $b = 0.485$, $c = 0.5$, $T_s = 0.1$

Sample time: 0.1 seconds

Discrete-time 2-DOF PIDF controller in parallel form.

The displays show the difference in resulting coefficient values and functional form.

Discretize a Continuous-Time 2-DOF PID Controller

Discretize a continuous-time 2-DOF PID controller and specify the integral and derivative filter formulas.

Create a continuous-time controller and discretize it using the zero-order-hold method of the `c2d` command.

```
C2con = pid2(10,5,3,0.5,1,1); % continuous-time 2-DOF PIDF controller
C2dis1 = c2d(C2con,0.1,'zoh')
```

```
C2dis1 =
```

$$u = K_p (b*r-y) + K_i \frac{T_s}{z-1} (r-y) + K_d \frac{1}{T_f+T_s/(z-1)} (c*r-y)$$

```
with Kp = 10, Ki = 5, Kd = 3.31, Tf = 0.552, b = 1, c = 1, Ts = 0.1
```

```
Sample time: 0.1 seconds
```

```
Discrete-time 2-DOF PIDF controller in parallel form.
```

The display shows that `c2d` computes new PID coefficients for the discrete-time controller.

The discrete integrator formulas of the discretized controller depend on the `c2d` discretization method, as described in “Tips” on page 2-930. For the `zoh` method, both `IFormula` and `DFormula` are `ForwardEuler`.

```
C2dis1.IFormula
```

```
ans =
'ForwardEuler'
```

```
C2dis1.DFormula
```

```
ans =
'ForwardEuler'
```

If you want to use different formulas from the ones returned by `c2d`, then you can directly set the `Ts`, `IFormula`, and `DFormula` properties of the controller to the desired values.

```
C2dis2 = C2con;
C2dis2.Ts = 0.1;
C2dis2.IFormula = 'BackwardEuler';
C2dis2.DFormula = 'BackwardEuler';
```

However, these commands do not compute new PID gains for the discretized controller. To see this, examine `C2dis2` and compare the coefficients to `C2con` and `C2dis1`.

```
C2dis2
```

```
C2dis2 =
```

$$u = K_p (b*r-y) + K_i \frac{T_s*z}{z-1} (r-y) + K_d \frac{1}{T_f+T_s*z/(z-1)} (c*r-y)$$

```
with Kp = 10, Ki = 5, Kd = 3, Tf = 0.5, b = 1, c = 1, Ts = 0.1
```

```
Sample time: 0.1 seconds
```

```
Discrete-time 2-DOF PIDF controller in parallel form.
```

Tips

- To design a PID controller for a particular plant, use `pidtune` or `pidTuner`. To create a tunable 2-DOF PID controller as a control design block, use `tunablePID2`.
- To break a 2-DOF controller into two SISO control components, such as a feedback controller and a feedforward controller, use `getComponents`.
- Create arrays of `pid2` controller objects by:
 - Specifying array values for one or more of the coefficients K_p , K_i , K_d , T_f , b , and c .
 - Specifying an array of dynamic systems `sys` to convert to `pid2` controller objects.
 - Using `stack` to build arrays from individual controllers or smaller arrays.
 - Passing an array of plant models to `pidtune`.

In an array of `pid2` controllers, each controller must have the same sample time T_s and discrete integrator formulas `IFormula` and `DFormula`.

- To create or convert to a standard-form controller, use `pidstd2`. Standard form expresses the controller actions in terms of an overall proportional gain K_p , integral and derivative times T_i and T_d , and filter divisor N . For example, the relationship between the inputs and output of a continuous-time standard-form 2-DOF PID controller is given by:

$$u = K_p \left[(br - y) + \frac{1}{T_i s} (r - y) + \frac{T_d s}{\frac{T_d}{N} s + 1} (cr - y) \right].$$

- There are two ways to discretize a continuous-time `pid2` controller:
 - Use the `c2d` command. `c2d` computes new parameter values for the discretized controller. The discrete integrator formulas of the discretized controller depend upon the `c2d` discretization method you use, as shown in the following table.

c2d Discretization Method	IFormula	DFormula
'zoh'	ForwardEuler	ForwardEuler
'foh'	Trapezoidal	Trapezoidal
'tustin'	Trapezoidal	Trapezoidal
'impulse'	ForwardEuler	ForwardEuler
'matched'	ForwardEuler	ForwardEuler

For more information about `c2d` discretization methods, See the `c2d` reference page. For more information about `IFormula` and `DFormula`, see “Properties” on page 2-917 .

- If you require different discrete integrator formulas, you can discretize the controller by directly setting T_s , `IFormula`, and `DFormula` to the desired values. (See “Discretize a Continuous-Time 2-DOF PID Controller” on page 2-928.) However, this method does not compute new gain and filter-constant values for the discretized controller. Therefore, this method might yield a poorer match between the continuous- and discrete-time `pid2` controllers than using `c2d`.

Version History

Introduced in R2015b

See Also

pidstd2 | pid | piddata2 | getComponents | make1DOF | pidtune | pidTuner | tunablePID2 | genss | realp

Topics

“Two-Degree-of-Freedom PID Controllers”

“Discrete-Time Proportional-Integral-Derivative (PID) Controllers”

“What Are Model Objects?”

piddata

Access coefficients of parallel-form PID controller

Syntax

```
[Kp,Ki,Kd,Tf] = piddata(sys)
[Kp,Ki,Kd,Tf,Ts] = piddata(sys)
[Kp,Ki,Kd,Tf,Ts] = piddata(sys,J1,...,JN)
```

Description

`[Kp,Ki,Kd,Tf] = piddata(sys)` returns the PID gains `Kp`, `Ki`, `Kd` and the filter time constant `Tf` of the parallel-form controller represented by the dynamic system `sys`.

`[Kp,Ki,Kd,Tf,Ts] = piddata(sys)` also returns the sample time `Ts`.

`[Kp,Ki,Kd,Tf,Ts] = piddata(sys,J1,...,JN)` extracts the data for a subset of entries in `sys`, where `sys` is an N -dimensional array of dynamic systems. The indices `J` specify the array entry to extract.

Input Arguments

sys

SISO dynamic system or array of SISO dynamic systems. If `sys` is not a `pid` object, it must represent a valid PID controller that can be written in parallel PID form.

J

Integer indices of N entries in the array `sys` of dynamic systems. For example, suppose `sys` is a 4-by-5 (two-dimensional) array of `pid` controllers or dynamic system models that represent PID controllers. The following command extracts the data for entry (2,3) in the array.

```
[Kp,Ki,Kd,Tf,Ts] = piddata(sys,2,3);
```

Output Arguments

Kp

Proportional gain of the parallel-form PID controller represented by dynamic system `sys`.

If `sys` is a `pid` controller object, the output `Kp` is equal to the `Kp` value of `sys`.

If `sys` is not a `pid` object, `Kp` is the proportional gain of a parallel PID controller equivalent to `sys`.

If `sys` is an array of dynamic systems, `Kp` is an array of the same dimensions as `sys`.

Ki

Integral gain of the parallel-form PID controller represented by dynamic system `sys`.

If `sys` is a `pid` controller object, then the output `Ki` is equal to the `Ki` value of `sys`.

If `sys` is not a `pid` object, then `Ki` is the integral gain of a parallel PID controller equivalent to `sys`.

If `sys` is an array of dynamic systems, then `Ki` is an array of the same dimensions as `sys`.

Kd

Derivative gain of the parallel-form PID controller represented by dynamic system `sys`.

If `sys` is a `pid` controller object, then the output `Kd` is equal to the `Kd` value of `sys`.

If `sys` is not a `pid` object, then `Kd` is the derivative gain of a parallel PID controller equivalent to `sys`.

If `sys` is an array of dynamic systems, then `Kd` is an array of the same dimensions as `sys`.

Tf

Filter time constant of the parallel-form PID controller represented by dynamic system `sys`.

If `sys` is a `pid` controller object, the output `Tf` is equal to the `Tf` value of `sys`.

If `sys` is not a `pid` object, `Tf` is the filter time constant of a parallel PID controller equivalent to `sys`.

If `sys` is an array of dynamic systems, `Tf` is an array of the same dimensions as `sys`.

Ts

Sample time of the dynamic system `sys`. `Ts` is always a scalar value.

Examples

Extract Coefficients From Parallel-Form PID Controller

Typically, you extract coefficients from a controller obtained from another function, such as `pidtune` or `getBlockValue`. For this example, create a PID controller that has random coefficients.

```
rng('default'); % for reproducibility
C = pid(rand,rand,rand,rand);
```

Extract the PID gains and filter time constant.

```
[Kp,Ki,Kd,Tf] = piddata(C)
```

```
Kp = 0.8147
```

```
Ki = 0.9058
```

```
Kd = 0.1270
```

```
Tf = 0.9134
```

Extract Parallel-Form Gains from Standard-Form PI Controller

Create a PI controller in standard form.

```
C = pidstd(2,3)
```

```
C =
```

$$K_p * \left(1 + \frac{1}{T_i} * \frac{1}{s} \right)$$

```
with Kp = 2, Ti = 3
```

Continuous-time PI controller in standard form

Compute the gains of an equivalent parallel-form PID controller.

```
[Kp,Ki] = piddata(C)
```

```
Kp = 2
```

```
Ki = 0.6667
```

Extract PID Coefficients from Equivalent System

Extract coefficients from dynamic system that represents a valid discrete-time parallel-form PID controller with a derivate filter.

$$H(z) = \frac{(z - 0.5)(z - 0.6)}{(z - 1)(z + 0.8)}$$

```
H = zpk([0.5 0.6],[1,-0.8],1,0.1);
```

Extract the PID gains and filter time constant.

```
[Kp,Ki,Kd,Tf,Ts] = piddata(H)
```

```
Kp = 0.4383
```

```
Ki = 1.1111
```

```
Kd = 0.0312
```

```
Tf = 0.0556
```

```
Ts = 0.1000
```

For a discrete-time system, `piddata` calculates the coefficient values using the default ForwardEuler discrete integrator formula for both IFormula and DFormula.

Extract Coefficients from PI Controller Array

Typically, you obtain an array of controllers by using `pidtune` on an array of plant models. For this example, create a 2-by-3 array of PI controllers with random values of K_p , K_i .

```
rng('default');
C = pid(rand(2,3),rand(2,3));
```

Extract all the coefficients from the array.

```
[Kp,Ki] = piddata(C);
```

Each of the outputs is itself a 2-by-3 array. For example, examine K_i .

K_i

```
Ki = 2x3
    0.2785    0.9575    0.1576
    0.5469    0.9649    0.9706
```

Extract only the coefficients of entry (2,1) in the array.

```
[Kp,Ki] = piddata(C,2,1)
```

```
Kp = 0.9058
```

```
Ki = 0.5469
```

Tips

If `sys` is not a `pid` controller object, `piddata` returns the PID gains K_p , K_i , K_d and the filter time constant T_f of a parallel-form controller equivalent to `sys`.

For discrete-time `sys`, `piddata` returns the parameters of an equivalent parallel-form controller. This controller has discrete integrator formulas `IFormula` and `DFormula` set to `ForwardEuler`. See the `pid` reference page for more information about discrete integrator formulas.

Version History

Introduced in R2010b

See Also

`pid` | `pidstd` | `get`

piddata2

Access coefficients of parallel-form 2-DOF PID controller

Syntax

```
[Kp,Ki,Kd,Tf,b,c] = piddata2(sys)
[Kp,Ki,Kd,Tf,b,c,Ts] = piddata2(sys)
[Kp,Ki,Kd,Tf,b,c,Ts] = piddata2(sys,J1,...,JN)
```

Description

`[Kp,Ki,Kd,Tf,b,c] = piddata2(sys)` returns the PID gains `Kp`, `Ki`, `Kd`, the filter time constant `Tf`, and the setpoint weights `b` and `c` of the parallel-form 2-DOF PID controller represented by the dynamic system `sys`.

If `sys` is a `pid2` controller object, then each output argument is the corresponding coefficient in `sys`.

If `sys` is not a `pid2` object, then each output argument is the corresponding coefficient of the parallel-form 2-DOF PID controller that is equivalent to `sys`.

If `sys` is an array of dynamic systems, then each output argument is an array of the same dimensions as `sys`.

`[Kp,Ki,Kd,Tf,b,c,Ts] = piddata2(sys)` also returns the sample time `Ts`. For discrete-time `sys` that is not a `pid2` object, `piddata2` calculates the coefficient values using the default ForwardEuler discrete integrator formula for both IFormula and DFormula. See the `pid2` reference page for more information about discrete integrator formulas.

`[Kp,Ki,Kd,Tf,b,c,Ts] = piddata2(sys,J1,...,JN)` extracts the data for a subset of entries in `sys`, where `sys` is an N-dimensional array of dynamic systems. The indices `J` specify the array entry to extract.

Examples

Extract Coefficients from Parallel-Form 2-DOF PID Controller

Typically, you extract coefficients from a controller obtained from another function, such as `pidtune` or `getBlockValue`. For this example, create a 2-DOF PID controller that has random coefficients.

```
rng('default'); % for reproducibility
C2 = pid2(rand,rand,rand,rand,rand,rand);
```

Extract the PID coefficients, filter time constant, and setpoint weights.

```
[Kp,Ki,Kd,Tf,b,c] = piddata2(C2);
```

Extract Parallel-Form Gains from Standard-Form Controller

Create a 2-DOF PID controller in standard form.

```
C2 = pidstd2(2,3,4,10,0.5,0.5)
```

```
C2 =
```

$$u = K_p * [(b*r-y) + \frac{1}{T_i} * \frac{1}{s} * (r-y) + T_d * \frac{s}{(T_d/N)*s+1} * (c*r-y)]$$

with $K_p = 2$, $T_i = 3$, $T_d = 4$, $N = 10$, $b = 0.5$, $c = 0.5$

Continuous-time 2-DOF PIDF controller in standard form

Compute the coefficients of an equivalent parallel-form PID controller.

```
[Kp,Ki,Kd,Tf,b,c] = piddata2(C2);
```

Check some of the coefficients to confirm that they are different from the standard-form coefficients.

```
Ki
```

```
Ki = 0.6667
```

```
Kd
```

```
Kd = 8
```

Extract 2-DOF PID Coefficients from Equivalent System

Extract coefficients from a two-input, one-output dynamic system that represents a valid 2-DOF parallel-form PID controller.

The following A, B, C, and D matrices form a discrete-time state-space model that represents a 2-DOF PID controller.

```
A = [1,0;0.09975,0.995];
B = [0.00625,-0.00625;0.1245,-0.1241];
C = [0,4];
D = [2.875,-5.75];
sys = ss(A,B,C,D,0.1)
```

```
sys =
```

```
A =
      x1      x2
x1      1      0
x2  0.09975  0.995
```

```
B =
      u1      u2
x1  0.00625 -0.00625
x2  0.1245  -0.1241
```

```

C =
    x1  x2
y1    0   4

D =
    u1  u2
y1  2.875 -5.75

```

Sample time: 0.1 seconds
Discrete-time state-space model.

Extract the PID gains, filter time constant, and setpoint weights of the model.

```
[Kp,Ki,Kd,Tf,b,c,Ts] = piddata2(sys);
```

For a discrete-time system, `piddata2` calculates the coefficient values using the default `ForwardEuler` discrete integrator formula for both `IFormula` and `DFormula`.

Extract Coefficients from 2-DOF PI Controller Array

Typically, you obtain an array of controllers by using `pidtune` on an array of plant models. For this example, create a 2-by-3 array of 2-DOF PI controllers with random values of `Kp`, `Ki`, and `b`.

```
rng('default');
C2 = pid2(rand(2,3),rand(2,3),0,0,rand(2,3),0);
```

Extract all the coefficients from the array.

```
[Kp,Ki,Kd,Tf,b,c] = piddata2(C2);
```

Each of the outputs is itself a 2-by-3 array. For example, examine `Ki`.

```

Ki
Ki = 2x3
    0.2785    0.9575    0.1576
    0.5469    0.9649    0.9706

```

Extract only the coefficients of entry (2,1) in the array.

```
[Kp21,Ki21,Kd21,Tf21,b21,c21] = piddata2(C2,2,1);
```

Each of these outputs is a scalar.

```

Ki21
Ki21 = 0.5469

```

Input Arguments

sys — 2-DOF PID controller

`pid2` controller object | dynamic system model | dynamic system array

2-DOF PID controller in parallel form, specified as a `pid2` controller object, a dynamic system model, or a dynamic system array. If `sys` is not a `pid2` controller object, it must be a two-input, one-output model that represents a valid 2-DOF PID controller that can be written in parallel form.

J – Indices

positive integers

Indices of entry to extract from a model array `sys`, specified as positive integers. Provide as many indices as there are array dimensions in `sys`. For example, suppose `sys` is a 4-by-5 (two-dimensional) array of `pid2` controllers or dynamic system models that represent 2-DOF PID controllers. The following command extracts the data for entry (2,3) in the array.

```
[Kp,Ki,Kd,Tf,b,c,Ts] = piddata2(sys,2,3);
```

Output Arguments

Kp – Proportional gain

scalar | array

Proportional gain of the parallel-form 2-DOF PID controller represented by `sys`, returned as a scalar or array.

If `sys` is a `pid2` controller object, then `Kp` is the `Kp` value of `sys`.

If `sys` is not a `pid2` object, then `Kp` is the proportional gain of the parallel-form 2-DOF PID controller that is equivalent to `sys`.

If `sys` is an array of dynamic systems, then `Kp` is an array of the same dimensions as `sys`.

Ki – Integral gain

scalar | array

Integral gain of the parallel-form 2-DOF PID controller represented by `sys`, returned as a scalar or array.

Kd – Derivative gain

scalar | array

Derivative gain of the parallel-form 2-DOF PID controller represented by `sys`, returned as a scalar or array.

Tf – Filter time constant

scalar | array

Filter time constant of the parallel-form 2-DOF PID controller represented by `sys`, returned as a scalar or array.

b – Setpoint weight on proportional term

scalar | array

Setpoint weight on the proportional term of the parallel-form 2-DOF PID controller represented by `sys`, returned as a scalar or array.

c – Setpoint weight on derivative term

scalar | array

Setpoint weight on the derivative term of the parallel-form 2-DOF PID controller represented by `sys`, returned as a scalar or array.

Ts — Sample time

scalar

Sample time of the `pid2` controller, dynamic system `sys`, or dynamic system array, returned as a scalar.

Version History

Introduced in R2015b

See Also

`pid2` | `pidstdata2` | `piddata`

pidstd

PID controller in standard form

Description

Use `pidstd` to create standard-form PID controller objects, or to convert dynamic system models to standard PID controller form.

The `pidstd` controller model object can represent standard-form PID controllers in continuous time or discrete time.

- Continuous time — $C = K_p \left(1 + \frac{1}{T_i} \frac{1}{s} + \frac{T_d s}{N s + 1} \right)$
- Discrete time — $C = K_p \left(1 + \frac{1}{T_i} IF(z) + \frac{T_d}{\frac{T_d}{N} + DF(z)} \right)$

Here:

- K_p is the proportional gain.
- T_i is the integral time.
- T_d is the derivative time.
- N is the first-order derivative filter divisor.
- $IF(z)$ is the integrator method for computing integral in discrete-time controller.
- $DF(z)$ is the integrator method for computing derivative filter in discrete-time controller.

You can then combine this object with other components of a control architecture, such as the plant, actuators, and sensors to represent your control system. For more information, see “Control System Modeling with Model Objects”.

You can create a PID controller model object by either specifying the controller parameters directly, or by converting a model of another type (such as a transfer function model `tf`) to PID controller form.

You can also use `pidstd` to create generalized state-space (`genss`) models or uncertain state-space (`uss`) models.

Creation

You can obtain `pidstd` controller models in one of the following ways.

- Create a model using the `pidstd` function.
- Use `pidtune` function to tune PID controller for a plant model. Specify a baseline standard-form PID controller type using the `C0` argument of the `pidtune` function. For example:

```
sys = zpk([],[-1 -1 -1],1);
C0 = pidstd(1,1,1);
C = pidtune(sys,C0)
```

- Interactively tune PID controller for a plant model using:
 - The **Tune PID Controller** Live Editor task.
 - The **PID Tuner** app.

Syntax

```
C = pidstd(Kp,Ti,Td,N)
C = pidstd(Kp,Ti,Td,N,Ts)
```

```
C = pidstd(Kp)
C = pidstd(Kp,Ti)
C = pidstd(Kp,Ti,Td)
```

```
C = pidstd( ____,Name,Value)
```

```
C = pidstd
```

```
C = pidstd(sys)
```

Description

`C = pidstd(Kp,Ti,Td,N)` creates a continuous-time standard-form PID controller model and sets the properties `Kp`, `Ti`, `Td`, and `N`. The remaining properties have default values.

`C = pidstd(Kp,Ti,Td,N,Ts)` creates a discrete-time PID controller model with sample time `Ts`.

`C = pidstd(Kp)` creates a continuous-time proportional (P) controller.

`C = pidstd(Kp,Ti)` creates a proportional and integral (PI) controller.

`C = pidstd(Kp,Ti,Td)` creates a proportional, integral, and derivative (PID) controller.

`C = pidstd(____,Name,Value)` sets properties of the `pidstd` controller object specified using one or more `Name,Value` arguments for any of the previous input-argument combinations.

`C = pidstd` creates a controller object with default property values. To modify the property of the controller model, use dot notation.

`C = pidstd(sys)` converts the dynamic system model `sys` to a standard-form `pidstd` controller object.

Input Arguments

sys — Proportional gain

dynamic system model | model array

Dynamic system, specified as a SISO dynamic system model or array of SISO dynamic system models. Dynamic systems that you can use include:

- Continuous-time or discrete-time numeric LTI models, such as `tf`, `zpk`, `ss`, or `pid` models.

- Generalized or uncertain LTI models such as `genss` or `uss` models. (Using uncertain models requires Robust Control Toolbox software.)

The resulting PID controller assumes

- current values of the tunable components for tunable control design blocks.
- nominal model values for uncertain control design blocks.
- Identified LTI models, such as `idtf`, `idss`, `idproc`, `idpoly`, and `idgrey` models. (Using identified models requires System Identification Toolbox software.)

Output Arguments

C — Standard-form PID controller model

`pidstd` model object | `genss` model object | `uss` model object

PID controller model, returned as:

- A standard-form PID controller (`pidstd`) model object, when all the gains have numeric values. When the gains are numeric arrays, `C` is an array of `pidstd` controller objects.
- A generalized state-space model (`genss`) object, when the numerator or denominator input arguments includes tunable parameters, such as `realp` parameters or generalized matrices (`genmat`).
- An uncertain state-space model (`uss`) object, when the numerator or denominator input arguments includes uncertain parameters. Using uncertain models requires Robust Control Toolbox software.

Properties

Kp — Proportional gain

1 (default) | scalar | vector | matrix | `realp` object

Proportional gain, specified as a real and finite value or a tunable object.

- To create a `pidstd` controller object, use a real and finite scalar value.
- To create an array of `pidstd` controller objects, use an array of real and finite values.
- To create a tunable controller model, use a tunable parameter (`realp`) or generalized matrix (`genmat`).
- To create a tunable gain-scheduled controller model, use a tunable surface created using `tunableSurface`.

Ti — Integral time

Inf (default) | scalar | vector | matrix | `realp` object

Integral time, specified as a real and positive value or a tunable object.

- To create a `pidstd` controller object, use a real and positive scalar value.
- To create an array of `pidstd` controller objects, use an array of real and positive values.
- To create a tunable controller model, use a tunable parameter (`realp`) or generalized matrix (`genmat`).
- To create a tunable gain-scheduled controller model, use a tunable surface created using `tunableSurface`.

Td – Derivative time

0 (default) | scalar | vector | matrix | realp object

Derivative time, specified as a real, finite, and nonnegative value or a tunable object.

- To create a `pidstd` controller object, use a real, finite, and nonnegative scalar value.
- To create an array of `pidstd` controller objects, use an array of real, finite, and nonnegative values.
- To create a tunable controller model, use a tunable parameter (`realp`) or generalized matrix (`genmat`).
- To create a tunable gain-scheduled controller model, use a tunable surface created using `tunableSurface`.

N – Derivative filter divisor

Inf (default) | scalar | vector | matrix | realp object

First-order derivative filter divisor, specified as a real and positive value or a tunable object.

- To create a `pidstd` controller object, use a real and positive scalar value.
- To create an array of `pidstd` controller objects, use an array of real and positive values.
- To create a tunable controller model, use a tunable parameter (`realp`) or generalized matrix (`genmat`).
- To create a tunable gain-scheduled controller model, use a tunable surface created using `tunableSurface`.

When $N = \text{Inf}$, the controller has no filter on the derivative action.

IFormula – Method for computing integral in discrete-time controller

'ForwardEuler' (default) | 'BackwardEuler' | 'Trapezoidal'

Discrete integrator formula $IF(z)$ for the integrator of the discrete-time `pidstd` controller:

$$C = K_p \left(1 + \frac{1}{T_i} IF(z) + \frac{T_d}{\frac{T_d}{N} + DF(z)} \right).$$

Specify `IFormula` as one of the following:

- 'ForwardEuler' — $IF(z) = \frac{T_s}{z-1}$.

This formula is best for small sample time, where the Nyquist limit is large compared to the bandwidth of the controller. For larger sample time, the `ForwardEuler` formula can result in instability, even when discretizing a system that is stable in continuous time.

- 'BackwardEuler' — $IF(z) = \frac{T_s z}{z-1}$.

An advantage of the `BackwardEuler` formula is that discretizing a stable continuous-time system using this formula always yields a stable discrete-time result.

- 'Trapezoidal' — $IF(z) = \frac{T_s z + 1}{2(z-1)}$.

An advantage of the `Trapezoidal` formula is that discretizing a stable continuous-time system using this formula always yields a stable discrete-time result. Of all available integration formulas, the `Trapezoidal` formula yields the closest match between frequency-domain properties of the discretized system and the corresponding continuous-time system.

When `C` is a continuous-time controller, `IFormula` is `''`.

DFormula — Method for computing derivative in discrete-time controller

`'ForwardEuler'` (default) | `'BackwardEuler'` | `'Trapezoidal'`

Discrete integrator formula $DF(z)$ for the derivative filter of the discrete-time `pidstd` controller:

$$C = K_p \left(1 + \frac{1}{T_i} IF(z) + \frac{T_d}{\frac{T_d}{N} + DF(z)} \right).$$

Specify `DFormula` as one of the following:

- `'ForwardEuler'` — $DF(z) = \frac{T_s}{z-1}$.

This formula is best for small sample time, where the Nyquist limit is large compared to the bandwidth of the controller. For larger sample time, the `ForwardEuler` formula can result in instability, even when discretizing a system that is stable in continuous time.

- `'BackwardEuler'` — $DF(z) = \frac{T_s z}{z-1}$.

An advantage of the `BackwardEuler` formula is that discretizing a stable continuous-time system using this formula always yields a stable discrete-time result.

- `'Trapezoidal'` — $DF(z) = \frac{T_s z + 1}{2(z-1)}$.

An advantage of the `Trapezoidal` formula is that discretizing a stable continuous-time system using this formula always yields a stable discrete-time result. Of all available integration formulas, the `Trapezoidal` formula yields the closest match between frequency-domain properties of the discretized system and the corresponding continuous-time system.

The `Trapezoidal` value for `DFormula` is not available for a `pidstd` controller with no derivative filter (`N = Inf`).

When `C` is a continuous-time controller, `DFormula` is `''`.

InputDelay — Input delay

0 (default)

This property is read-only.

Time delay on the system input. `InputDelay` is always 0 for a `pidstd` controller object.

OutputDelay — Output delay

0 (default)

This property is read-only.

Time delay on the system output. `OutputDelay` is always 0 for a `pidstd` controller object.

Ts — Sample time

0 (default) | positive scalar

Sample time, specified as:

- 0 for continuous-time systems.
- A positive scalar representing the sampling period of a discrete-time system. Specify `Ts` in the time unit specified by the `TimeUnit` property.

PID controller models do not support unspecified sample time (`Ts = -1`).

Note Changing `Ts` does not discretize or resample the model. To convert between continuous-time and discrete-time representations, use `c2d` and `d2c`. To change the sample time of a discrete-time system, use `d2d`.

The discrete integrator formulas of the discretized controller depend upon the `c2d` discretization method you use, as shown in this table.

c2d Discretization Method	IFormula	DFormula
'zoh'	ForwardEuler	ForwardEuler
'foh'	Trapezoidal	Trapezoidal
'tustin'	Trapezoidal	Trapezoidal
'impulse'	ForwardEuler	ForwardEuler
'matched'	ForwardEuler	ForwardEuler

For more information about `c2d` discretization methods, see `c2d`.

If you require different discrete integrator formulas, you can discretize the controller by directly setting `Ts`, `IFormula`, and `DFormula` to the desired values. However, this method does not compute new gain and filter-constant values for the discretized controller. Therefore, this method might yield a poorer match between the continuous-time and discrete-time PID controllers than using `c2d`.

TimeUnit — Time variable units

'seconds' (default) | 'nanoseconds' | 'microseconds' | 'milliseconds' | 'minutes' | 'hours' | 'days' | 'weeks' | 'months' | 'years' | ...

Time variable units, specified as one of the following:

- 'nanoseconds'
- 'microseconds'
- 'milliseconds'
- 'seconds'
- 'minutes'
- 'hours'
- 'days'

- 'weeks'
- 'months'
- 'years'

Changing `TimeUnit` has no effect on other properties, but changes the overall system behavior. Use `chgTimeUnit` to convert between time units without modifying system behavior.

InputName — Input channel names

' (default) | character vector

Input channel name, specified as one of the following:

- A character vector.
- '', no name specified.

Alternatively, assign the name `error` to the input of a controller model `C` as follows.

```
C.InputName = 'error';
```

You can use the shorthand notation `u` to refer to the `InputName` property. For example, `C.u` is equivalent to `C.InputName`.

Use `InputName` to:

- Identify channels on model display and plots.
- Specify connection points when interconnecting models.

InputUnit — Input channel units

' (default) | character vector

Input channel units, specified as one of the following:

- A character vector.
- '', no units specified.

Use `InputUnit` to specify input signal units. `InputUnit` has no effect on system behavior.

For example, assign the concentration units 'mol/m³' to the input of a controller model `C` as follows.

```
C.InputUnit = 'mol/m^3';
```

InputGroup — Input channel groups

structure

Input channel groups. This property is not needed for PID controller models.

By default, `InputGroup` is a structure with no fields.

OutputName — Output channel names

' (default) | character vector

Output channel name, specified as one of the following:

- A character vector.
- `''`, no name specified.

For example, assign the name `'control'` to the output of a controller model `C` as follows.

```
C.OutputName = 'control';
```

You can also use the shorthand notation `y` to refer to the `OutputName` property. For example, `C.y` is equivalent to `C.OutputName`.

Use `OutputName` to:

- Identify channels on model display and plots.
- Specify connection points when interconnecting models.

OutputUnit — Output channel units

`''` (default) | character vector

Output channel units, specified as one of the following:

- A character vector.
- `''`, no units specified.

Use `OutputUnit` to specify output signal units. `OutputUnit` has no effect on system behavior.

For example, assign the unit `'volts'` to the output of a controller model `C` as follows.

```
C.OutputUnit = 'volts';
```

OutputGroup — Output channel groups

structure

Output channel groups. This property is not needed for PID controller models.

By default, `OutputGroup` is a structure with no fields.

Notes — User-specified text

`{}` (default) | character vector | cell array of character vectors

User-specified text that you want to associate with the system, specified as a character vector or cell array of character vectors. For example, `'System is MIMO'`.

UserData — User-specified data

`[]` (default) | any MATLAB data type

User-specified data that you want to associate with the system, specified as any MATLAB data type.

Name — System name

`''` (default) | character vector

System name, specified as a character vector. For example, `'system_1'`.

SamplingGrid — Sampling grid for model arrays

structure array

Sampling grid for model arrays, specified as a structure array.

Use `SamplingGrid` to track the variable values associated with each model in a model array, including identified linear time-invariant (IDLTI) model arrays.

Set the field names of the structure to the names of the sampling variables. Set the field values to the sampled variable values associated with each model in the array. All sampling variables must be numeric scalars, and all arrays of sampled values must match the dimensions of the model array.

For example, you can create an 11-by-1 array of linear models, `sysarr`, by taking snapshots of a linear time-varying system at times `t = 0:10`. The following code stores the time samples with the linear models.

```
sysarr.SamplingGrid = struct('time',0:10)
```

Similarly, you can create a 6-by-9 model array, `M`, by independently sampling two variables, `zeta` and `w`. The following code maps the (`zeta,w`) values to `M`.

```
[zeta,w] = ndgrid(<6 values of zeta>,<9 values of w>)
M.SamplingGrid = struct('zeta',zeta,'w',w)
```

When you display `M`, each entry in the array includes the corresponding `zeta` and `w` values.

`M`

```
M(:,:,1,1) [zeta=0.3, w=5] =
```

```
      25
-----
s^2 + 3 s + 25
```

```
M(:,:,2,1) [zeta=0.35, w=5] =
```

```
      25
-----
s^2 + 3.5 s + 25
```

...

For model arrays generated by linearizing a Simulink model at multiple parameter values or operating points, the software populates `SamplingGrid` automatically with the variable values that correspond to each entry in the array. For instance, the Simulink Control Design commands `linearize` and `sLinearizer` populate `SamplingGrid` automatically.

By default, `SamplingGrid` is a structure with no fields.

Object Functions

The following lists contain a representative subset of the functions you can use with `pidstd` models. In general, any function applicable to “Dynamic System Models” is applicable to a `pidstd` object.

Linear Analysis

<code>step</code>	Step response plot of dynamic system; step response data
<code>impulse</code>	Impulse response plot of dynamic system; impulse response data

lsim	Plot simulated time response of dynamic system to arbitrary inputs; simulated response data
bode	Bode plot of frequency response, or magnitude and phase data
nyquist	Nyquist plot of frequency response
nichols	Nichols chart of frequency response
bandwidth	Frequency response bandwidth

Stability Analysis

pole	Poles of dynamic system
zero	Zeros and gain of SISO dynamic system
pzplot	Pole-zero plot of dynamic system model with additional plot customization options
margin	Gain margin, phase margin, and crossover frequencies

Model Transformation

zpk	Zero-pole-gain model
ss	State-space model
c2d	Convert model from continuous to discrete time
d2c	Convert model from discrete to continuous time
d2d	Resample discrete-time model

Model Interconnection

feedback	Feedback connection of multiple models
connect	Block diagram interconnections of dynamic systems
series	Series connection of two models
parallel	Parallel connection of two models

Controller Design

pidtune	PID tuning algorithm for linear plant model
rlocus	Root locus plot of dynamic system
pidstddata	Access coefficients of standard-form PID controller
make2DOF	Convert 1-DOF PID controller to 2-DOF controller
pidTuner	Open PID Tuner for PID tuning
tunablePID	Tunable PID controller

Examples

Create Continuous-Time Standard-Form PDF Controller

Create a continuous-time standard-form PDF controller with proportional and derivative terms, and a filter divisor. To do so, set the integral time to infinite. Set the other gains and the filter divisor constant to the desired values.

```
Kp = 1;  
Ti = Inf;  
Td = 3;  
N = 6;  
C = pidstd(Kp,Ti,Td,N)  
  
C =
```

$$K_p * (1 + T_d * \frac{s}{(T_d/N)*s+1})$$

with $K_p = 1$, $T_d = 3$, $N = 6$

Continuous-time PDF controller in standard form

The display shows the controller type, formula, and parameter values, and verifies that the controller has no integrator term.

Discrete-Time Standard-Form PI Controller

Create a discrete-time standard-form PI controller with trapezoidal discretization formula.

To create a discrete-time PI controller, set the value of T_s and the discretization formula using `Name, Value` syntax.

```
C2 = pidstd(1,0.5,'Ts',0.1,'IFormula','Trapezoidal') % Ts = 0.1s
```

C2 =

$$K_p * (1 + \frac{1}{T_i} * \frac{T_s*(z+1)}{2*(z-1)})$$

with $K_p = 1$, $T_i = 0.5$, $T_s = 0.1$

Sample time: 0.1 seconds

Discrete-time PI controller in standard form

Alternatively, you can create the same discrete-time controller by supplying T_s as the fifth input argument after all four PID parameters, K_p , T_i , T_d , and N . Since you only want a PI controller, set T_d to zero and N to infinite.

```
C2 = pidstd(5,2.4,0,Inf,0.1,'IFormula','Trapezoidal')
```

C2 =

$$K_p * (1 + \frac{1}{T_i} * \frac{T_s*(z+1)}{2*(z-1)})$$

with $K_p = 5$, $T_i = 2.4$, $T_s = 0.1$

Sample time: 0.1 seconds

Discrete-time PI controller in standard form

The display shows that C1 and C2 are the same.

Standard-Form PID Controller with Named Input and Output

When you create a PID controller, set the dynamic system properties `InputName` and `OutputName`. This is useful, for example, when you interconnect the PID controller with other dynamic system models using the `connect` command.

```
C = pidstd(1,2,3, 'InputName', 'e', 'OutputName', 'u')
```

```
C =
```

$$K_p * \left(1 + \frac{1}{T_i} * \frac{1}{s} + T_d * s \right)$$

with $K_p = 1$, $T_i = 2$, $T_d = 3$

Continuous-time PID controller in standard form

The display does not show the input and output names for the PID controller, but you can examine the property values. For instance, verify the input name of the controller.

```
C.InputName
```

```
ans = 1x1 cell array
      {'e'}
```

Array of Standard-Form PID Controllers

Create a 2-by-3 grid of PI controllers with proportional gain ranging from 1-2 across the array rows and integral gain ranging from 5-9 across columns.

To build the array of PID controllers, start with arrays representing the gains.

```
Kp = [1 1 1; 2 2 2];
Ti = [5:2:9; 5:2:9];
```

When you pass these arrays to the `pidstd` command, the command returns an array of controllers.

```
pi_array = pidstd(Kp,Ti, 'Ts', 0.1, 'IFormula', 'BackwardEuler');
size(pi_array)
```

```
2x3 array of PID controller.
Each PID has 1 output and 1 input.
```

Alternatively, use the `stack` command to build an array of PID controllers.

Create a PID controller.

```
C = pidstd(1,5,0.1)
```

```
C =
```

$$K_p * \left(1 + \frac{1}{T_i} * \frac{1}{s} + T_d * s \right)$$

with $K_p = 1$, $T_i = 5$, $T_d = 0.1$

Continuous-time PID controller in standard form

Create a PIDF controller.

```
Cf = pidstd(1,5,0.1,0.5)
```

Cf =

$$K_p * \left(1 + \frac{1}{T_i} * \frac{1}{s} + T_d * \frac{s}{(T_d/N)*s+1} \right)$$

with $K_p = 1$, $T_i = 5$, $T_d = 0.1$, $N = 0.5$

Continuous-time PIDF controller in standard form

Stack the controllers along the second array dimension.

```
pid_array = stack(2,C,Cf);
```

This command returns a 1-by-2 array of controllers.

```
size(pid_array)
```

1x2 array of PID controller.
Each PID has 1 output and 1 input.

All PID controllers in an array must have the same sample time, discrete integrator formulas, and dynamic system properties such as `InputName` and `OutputName`.

Convert PID Controller from Parallel to Standard Form

Convert a parallel-form pid controller to standard form.

Parallel PID form expresses the controller actions in terms of an overall proportional, integral, and derivative gains K_p , K_i and K_d , and a filter time constant T_f . You can convert any parallel-form controller to standard form using the `pidstd` command, provided that:

- The parallel-form controller is not a pure integrator.
- The gains K_p , K_i and K_d all have the same sign.

For example, consider the following parallel-form controller.

```
Kp = 2;
Ki = 3;
Kd = 4;
Tf = 5;
C_par = pid(Kp,Ki,Kd,Tf)
```

C_par =

1 s

$$K_p + K_i * \frac{1}{s} + K_d * \frac{s}{T_f * s + 1}$$

with $K_p = 2$, $K_i = 3$, $K_d = 4$, $T_f = 5$

Continuous-time PIDF controller in parallel form.

Convert this controller to standard form using `pidstd`.

```
C_std = pidstd(C_par)
```

```
C_std =
```

$$K_p * \left(1 + \frac{1}{T_i} * \frac{1}{s} + T_d * \frac{s}{(T_d/N) * s + 1} \right)$$

with $K_p = 2$, $T_i = 0.667$, $T_d = 2$, $N = 0.4$

Continuous-time PIDF controller in standard form

Convert Dynamic System to Standard-Form PID Controller

Convert a continuous-time dynamic system that represents a PID controller to standard `pidstd` form.

The following dynamic system, with an integrator and two zeros, is equivalent to a PID controller.

$$H(s) = \frac{3(s+1)(s+2)}{s}$$

Create a `zpk` model of H . Then use the `pidstd` command to obtain H in terms of the PID gains K_p , T_i , and T_d .

```
H = zpk([-1, -2], 0, 3);
```

```
C = pidstd(H)
```

```
C =
```

$$K_p * \left(1 + \frac{1}{T_i} * \frac{1}{s} + T_d * s \right)$$

with $K_p = 9$, $T_i = 1.5$, $T_d = 0.333$

Continuous-time PID controller in standard form

Convert Discrete-Time Dynamic System to Standard-Form PID Controller

Convert a discrete-time dynamic system that represents a PID controller with derivative filter to standard `pidstd` form.

Create a discrete-time `zpk` model that represents a PIDF controller (two zeros and two poles, including the integrator pole at $z = 1$).

```
sys = zpk([-0.5, -0.6], [1 -0.2], 3, 'Ts', 0.1);
```

When you convert `sys` to PID form, the result depends on which discrete integrator formulas you specify for the conversion. For instance, use the default, `ForwardEuler`, for both the integrator and the derivative.

```
C = pidstd(sys)
```

```
C =
```

$$K_p * \left(1 + \frac{1}{T_i} * \frac{T_s}{z-1} + T_d * \frac{1}{(T_d/N) + T_s/(z-1)} \right)$$

```
with Kp = 2.75, Ti = 0.0458, Td = 0.00758, N = 0.0909, Ts = 0.1
```

```
Sample time: 0.1 seconds
```

```
Discrete-time PIDF controller in standard form
```

For this particular dynamic system, you cannot write `sys` in standard PID form using the `BackwardEuler` formula for the derivative filter. Doing so would result in $N < 0$, which is not permitted. In that case, `pidstd` returns an error.

Similarly, you cannot write `sys` in standard PID form using the `Trapezoidal` formula. Doing so would result in negative T_i and T_d , which is also not permitted.

Discretize Continuous-Time Standard-Form PID Controller

Discretize a continuous-time PID controller and set integral and derivative filter formulas.

Create a continuous-time PIDF controller and discretize it using the zero-order-hold method of the `c2d` command.

```
Ccon = pidstd(1,2,3,4);
Cdis1 = c2d(Ccon,0.1,'zoh')
```

```
Cdis1 =
```

$$K_p * \left(1 + \frac{1}{T_i} * \frac{T_s}{z-1} + T_d * \frac{1}{(T_d/N) + T_s/(z-1)} \right)$$

```
with Kp = 1, Ti = 2, Td = 3.2, N = 4, Ts = 0.1
```

```
Sample time: 0.1 seconds
```

```
Discrete-time PIDF controller in standard form
```

The display shows that `c2d` computes new PID gains for the discrete-time controller.

The discrete integrator formulas of the discretized controller depend on the `c2d` discretization method. For the `zoh` method, both `IFormula` and `DFormula` are `ForwardEuler`.

```
Cdis1.IFormula
```

```
ans =
'ForwardEuler'
```

```
Cdis1.DFormula
```

```
ans =
'ForwardEuler'
```

If you want to use different formulas from the ones returned by `c2d`, then you can directly set the `Ts`, `IFormula`, and `DFormula` properties of the controller to the desired values.

```
Cdis2 = Ccon;
Cdis2.Ts = 0.1;
Cdis2.IFormula = 'BackwardEuler';
Cdis2.DFormula = 'BackwardEuler';
```

However, these commands do not compute new PID gains for the discretized controller. To see this, examine `Cdis2` and compare the coefficients to `Ccon` and `Cdis1`.

```
Cdis2
```

```
Cdis2 =
```

$$K_p * \left(1 + \frac{1}{T_i} * \frac{T_s * z}{z-1} + T_d * \frac{1}{(T_d/N) + T_s * z / (z-1)} \right)$$

with $K_p = 1$, $T_i = 2$, $T_d = 3$, $N = 4$, $T_s = 0.1$

Sample time: 0.1 seconds

Discrete-time PIDF controller in standard form

Version History

Introduced in R2010b

See Also

`pid` | `pidstd2` | `pidstddata` | `pidtune` | `pidTuner`

Topics

“Proportional-Integral-Derivative (PID) Controllers”

“Discrete-Time Proportional-Integral-Derivative (PID) Controllers”

“What Are Model Objects?”

pidstd2

Create 2-DOF PID controller in standard form, convert to standard-form 2-DOF PID controller

Syntax

```
C2 = pidstd2(Kp,Ti,Td,N,b,c)
C2 = pidstd2(Kp,Ti,Td,N,b,c,Ts)
C2 = pidstd2(sys)
C2 = pid2( ___,Name,Value)
```

Description

`pid2` controller objects represent two-degree-of-freedom (2-DOF) PID controllers in parallel form. Use `pid2` either to create a `pid2` controller object from known coefficients or to convert a dynamic system model to a `pid2` object.

Two-degree-of-freedom (2-DOF) PID controllers include setpoint weighting on the proportional and derivative terms. A 2-DOF PID controller is capable of fast disturbance rejection without significant increase of overshoot in setpoint tracking. 2-DOF PID controllers are also useful to mitigate the influence of changes in the reference signal on the control signal. The following illustration shows a typical control architecture using a 2-DOF PID controller.

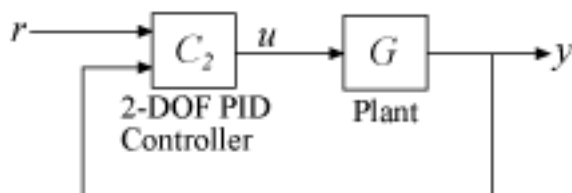

`C2 = pidstd2(Kp,Ti,Td,N,b,c)` creates a continuous-time 2-DOF PID controller with proportional gain K_p , integrator and derivative time constants T_i and T_d , and derivative filter divisor N . The controller also has setpoint weighting b on the proportional term, and setpoint weighting c on the derivative term. The relationship between the 2-DOF controller's output (u) and its two inputs (r and y) is given by:

$$u = K_p \left[(br - y) + \frac{1}{T_i s} (r - y) + \frac{T_d s}{N s + 1} (cr - y) \right].$$

This representation is in standard form. If all of the coefficients are real-valued, then the resulting `C2` is a `pidstd2` controller object. If one or more of these coefficients is tunable (`realp` or `genmat`), then `C2` is a tunable generalized state-space (`genss`) model object.

`C2 = pidstd2(Kp,Ti,Td,N,b,c,Ts)` creates a discrete-time 2-DOF PID controller with sample time T_s . The relationship between the controller's output and inputs is given by:

$$u = K_p \left[(br - y) + \frac{1}{T_i} IF(z)(r - y) + \frac{T_d}{\frac{T_d}{N} + DF(z)} (cr - y) \right].$$

$IF(z)$ and $DF(z)$ are the discrete integrator formulas for the integrator and derivative filter. By default,

$$IF(z) = DF(z) = \frac{T_s}{z - 1}.$$

To choose different discrete integrator formulas, use the `IFormula` and `DFormula` properties. (See “Properties” on page 2-961 for more information). If `DFormula` = 'ForwardEuler' (the default value) and `N` \neq `Inf`, then `Ts`, `Td`, and `N` must satisfy $T_d/N > T_s/2$. This requirement ensures a stable derivative filter pole.

`C2 = pidstd2(sys)` converts the dynamic system `sys` to a standard form `pidstd2` controller object.

`C2 = pid2(____, Name, Value)` specifies additional properties as comma-separated pairs of `Name, Value` arguments.

Input Arguments

Kp

Proportional gain.

Kp can be:

- A real and finite value.
- An array of real and finite values.
- A tunable parameter (`realp`) or generalized matrix (`genmat`).
- A tunable surface for gain-scheduled tuning, created using `tunableSurface`.

Default: 1

Ti

Integrator time.

Ti can be:

- A real and positive value.
- An array of real and positive values.
- A tunable parameter (`realp`) or generalized matrix (`genmat`).
- A tunable surface for gain-scheduled tuning, created using `tunableSurface`.

When `Ti` = `Inf`, the controller has no integral action.

Default: `Inf`

Td

Derivative time.

Td can be:

- A real, finite, and nonnegative value.
- An array of real, finite, and nonnegative values.
- A tunable parameter (`realp`) or generalized matrix (`genmat`).
- A tunable surface for gain-scheduled tuning, created using `tunableSurface`.

When $T_d = 0$, the controller has no derivative action.

Default: 0

N

Derivative filter divisor.

N can be:

- A real and positive value.
- An array of real and positive values.
- A tunable parameter (`realp`) or generalized matrix (`genmat`).
- A tunable surface for gain-scheduled tuning, created using `tunableSurface`.

When $N = \text{Inf}$, the controller has no filter on the derivative action.

Default: Inf

b

Setpoint weighting on proportional term.

b can be:

- A real, nonnegative, and finite value.
- An array of real, nonnegative, finite values.
- A tunable parameter (`realp`) or generalized matrix (`genmat`).
- A tunable surface for gain-scheduled tuning, created using `tunableSurface`.

When $b = 0$, changes in setpoint do not feed directly into the proportional term.

Default: 1

c

Setpoint weighting on derivative term.

c can be:

- A real, nonnegative, and finite value.
- An array of real, nonnegative, finite values.
- A tunable parameter (`realp`) or generalized matrix (`genmat`).
- A tunable surface for gain-scheduled tuning, created using `tunableSurface`.

When $c = 0$, changes in setpoint do not feed directly into the derivative term.

Default: 1

Ts

Sample time.

To create a discrete-time `pidstd2` controller, provide a positive real value ($T_s > 0$). `pidstd2` does not support discrete-time controller with undetermined sample time ($T_s = -1$).

T_s must be a scalar value. In an array of `pidstd2` controllers, each controller must have the same T_s .

Default: 0 (continuous time)

sys

SISO dynamic system to convert to standard `pidstd2` form.

`sys` be a two-input, one-output system. `sys` must represent a valid 2-DOF controller that can be written in standard form with $T_i > 0$, $T_d \geq 0$, and $N > 0$.

`sys` can also be an array of SISO dynamic systems.

Name-Value Pair Arguments

Specify optional comma-separated pairs of `Name`, `Value` arguments. `Name` is the argument name and `Value` is the corresponding value. `Name` must appear inside quotes. You can specify several name and value pair arguments in any order as `Name1, Value1, ..., NameN, ValueN`.

Use `Name, Value` syntax to set the numerical integration formulas `IFormula` and `DFormula` of a discrete-time `pidstd2` controller, or to set other object properties such as `InputName` and `OutputName`. For information about available properties of `pidstd2` controller objects, see "Properties" on page 2-961.

Output Arguments

C2

2-DOF PID controller, returned as a `pidstd2` controller object, an array of `pidstd2` controller objects, a `genss` object, or a `genss` array.

- If all the coefficients have scalar numeric values, then `C2` is a `pidstd2` controller object.
- If one or more coefficients is a numeric array, `C2` is an array of `pidstd2` controller objects. The controller type (such as PI, PID, or PDF) depends upon the values of the gains. For example, when $T_d = 0$, but K_p and T_i are nonzero and finite, `C2` is a PI controller.
- If one or more coefficients is a tunable parameter (`realp`), generalized matrix (`genmat`), or tunable gain surface (`tunableSurface`), then `C2` is a generalized state-space model (`genss`).

Properties

b, c

Setpoint weights on the proportional and derivative terms, respectively. **b** and **c** values are real, finite, and positive. When you create a 2-DOF PID controller using the `pidstd2` command, the initial values of these properties are set by the **b**, and **c** input arguments, respectively.

Kp

Proportional gain.

The value of **Kp** is real and finite. When you create a 2-DOF PID controller using the `pidstd2` command, the initial value of this property is set by the **Kp** input argument.

Ti

Integrator time. **Ti** is real and positive. When you create a 2-DOF PID controller using the `pidstd2` command, the initial value of this property is set by the **Ti** input argument. When **Ti** = `Inf`, the controller has no integral action.

Td

Derivative time. **Td** is real, finite, and nonnegative. When you create a 2-DOF PID controller using the `pidstd2` command, the initial value of this property is set by the **Td** input argument. When **Td** = 0, the controller has no derivative action.

N

Derivative filter divisor. **N** must be real and positive. When you create a 2-DOF PID controller using the `pidstd2` command, the initial value of this property is set by the **N** input argument.

IFormula

Discrete integrator formula $IF(z)$ for the integrator of the discrete-time `pidstd2` controller `C2`. The relationship between the inputs and output of `C2` is given by:

$$u = K_p \left[(br - y) + \frac{1}{T_i} IF(z)(r - y) + \frac{T_d}{\frac{T_d}{N} + DF(z)} (cr - y) \right].$$

IFormula can take the following values:

- 'ForwardEuler' — $IF(z) = \frac{T_s}{z - 1}$.

This formula is best for small sample time, where the Nyquist limit is large compared to the bandwidth of the controller. For larger sample time, the `ForwardEuler` formula can result in instability, even when discretizing a system that is stable in continuous time.

- 'BackwardEuler' — $IF(z) = \frac{T_s z}{z - 1}$.

An advantage of the `BackwardEuler` formula is that discretizing a stable continuous-time system using this formula always yields a stable discrete-time result.

- 'Trapezoidal' — $IF(z) = \frac{T_s z + 1}{2 z - 1}$.

An advantage of the Trapezoidal formula is that discretizing a stable continuous-time system using this formula always yields a stable discrete-time result. Of all available integration formulas, the Trapezoidal formula yields the closest match between frequency-domain properties of the discretized system and the corresponding continuous-time system.

When C2 is a continuous-time controller, IFormula is ''.

Default: 'ForwardEuler'

DFormula

Discrete integrator formula $DF(z)$ for the derivative filter of the discrete-time pidstd2 controller C2. The relationship between the inputs and output of C2 is given by:

$$u = K_p \left[(br - y) + \frac{1}{T_i} IF(z)(r - y) + \frac{T_d}{\frac{T_d}{N} + DF(z)}(cr - y) \right].$$

DFormula can take the following values:

- 'ForwardEuler' — $DF(z) = \frac{T_s}{z - 1}$.

This formula is best for small sample time, where the Nyquist limit is large compared to the bandwidth of the controller. For larger sample time, the ForwardEuler formula can result in instability, even when discretizing a system that is stable in continuous time.

- 'BackwardEuler' — $DF(z) = \frac{T_s z}{z - 1}$.

An advantage of the BackwardEuler formula is that discretizing a stable continuous-time system using this formula always yields a stable discrete-time result.

- 'Trapezoidal' — $DF(z) = \frac{T_s z + 1}{2 z - 1}$.

An advantage of the Trapezoidal formula is that discretizing a stable continuous-time system using this formula always yields a stable discrete-time result. Of all available integration formulas, the Trapezoidal formula yields the closest match between frequency-domain properties of the discretized system and the corresponding continuous-time system.

The Trapezoidal value for DFormula is not available for a pidstd2 controller with no derivative filter ($N = \text{Inf}$).

When C2 is a continuous-time controller, DFormula is ''.

Default: 'ForwardEuler'

InputDelay

Time delay on the system input. InputDelay is always 0 for a pidstd2 controller object.

OutputDelay

Time delay on the system Output. `OutputDelay` is always 0 for a `pidstd2` controller object.

Ts

Sample time. For continuous-time models, $T_s = 0$. For discrete-time models, T_s is a positive scalar representing the sampling period. This value is expressed in the unit specified by the `TimeUnit` property of the model. PID controller models do not support unspecified sample time ($T_s = -1$).

Changing this property does not discretize or resample the model. Use `c2d` and `d2c` to convert between continuous- and discrete-time representations. Use `d2d` to change the sample time of a discrete-time system.

Default: 0 (continuous time)

TimeUnit

Units for the time variable, the sample time T_s , and any time delays in the model, specified as one of the following values:

- 'nanoseconds'
- 'microseconds'
- 'milliseconds'
- 'seconds'
- 'minutes'
- 'hours'
- 'days'
- 'weeks'
- 'months'
- 'years'

Changing this property has no effect on other properties, and therefore changes the overall system behavior. Use `chgTimeUnit` to convert between time units without modifying system behavior.

Default: 'seconds'

InputName

Input channel name, specified as a character vector or a 2-by-1 cell array of character vectors. Use this property to name the input channels of the controller model. For example, assign the names `setpoint` and `measurement` to the inputs of a 2-DOF PID controller model `C` as follows.

```
C.InputName = {'setpoint'; 'measurement'};
```

Alternatively, use automatic vector expansion to assign both input names. For example:

```
C.InputName = 'C-input';
```

The input names automatically expand to `{'C-input(1)'; 'C-input(2)'}`.

You can use the shorthand notation `u` to refer to the `InputName` property. For example, `C.u` is equivalent to `C.InputName`.

Input channel names have several uses, including:

- Identifying channels on model display and plots
- Specifying connection points when interconnecting models

Default: { '' ; '' }

InputUnit

Input channel units, specified as a 2-by-1 cell array of character vectors. Use this property to track input signal units. For example, assign the units `Volts` to the reference input and the concentration units `mol/m^3` to the measurement input of a 2-DOF PID controller model `C` as follows.

```
C.InputUnit = {'Volts'; 'mol/m^3'};
```

`InputUnit` has no effect on system behavior.

Default: { '' ; '' }

InputGroup

Input channel groups. This property is not needed for PID controller models.

Default: struct with no fields

OutputName

Output channel name, specified as a character vector. Use this property to name the output channel of the controller model. For example, assign the name `control` to the output of a controller model `C` as follows.

```
C.OutputName = 'control';
```

You can use the shorthand notation `y` to refer to the `OutputName` property. For example, `C.y` is equivalent to `C.OutputName`.

Input channel names have several uses, including:

- Identifying channels on model display and plots
- Specifying connection points when interconnecting models

Default: Empty character vector, ''

OutputUnit

Output channel units, specified as a character vector. Use this property to track output signal units. For example, assign the unit `Volts` to the output of a controller model `C` as follows.

```
C.OutputUnit = 'Volts';
```

`OutputUnit` has no effect on system behavior.

Default: Empty character vector, ''

OutputGroup

Output channel groups. This property is not needed for PID controller models.

Default: struct with no fields

Name

System name, specified as a character vector. For example, 'system_1'.

Default: ''

Notes

Any text that you want to associate with the system, stored as a string or a cell array of character vectors. The property stores whichever data type you provide. For instance, if `sys1` and `sys2` are dynamic system models, you can set their `Notes` properties as follows:

```
sys1.Notes = "sys1 has a string.";
sys2.Notes = 'sys2 has a character vector.';
sys1.Notes
sys2.Notes
```

```
ans =
```

```
    "sys1 has a string."
```

```
ans =
```

```
    'sys2 has a character vector.'
```

Default: [0×1 string]

UserData

Any type of data you want to associate with system, specified as any MATLAB data type.

Default: []

SamplingGrid

Sampling grid for model arrays, specified as a data structure.

For model arrays that are derived by sampling one or more independent variables, this property tracks the variable values associated with each model in the array. This information appears when you display or plot the model array. Use this information to trace results back to the independent variables.

Set the field names of the data structure to the names of the sampling variables. Set the field values to the sampled variable values associated with each model in the array. All sampling variables should be numeric and scalar valued, and all arrays of sampled values should match the dimensions of the model array.

For example, suppose you create a 11-by-1 array of linear models, `sysarr`, by taking snapshots of a linear time-varying system at times `t = 0:10`. The following code stores the time samples with the linear models.

```
sysarr.SamplingGrid = struct('time',0:10)
```

Similarly, suppose you create a 6-by-9 model array, *M*, by independently sampling two variables, *zeta* and *w*. The following code attaches the (*zeta*,*w*) values to *M*.

```
[zeta,w] = ndgrid(<6 values of zeta>,<9 values of w>)
M.SamplingGrid = struct('zeta',zeta,'w',w)
```

When you display *M*, each entry in the array includes the corresponding *zeta* and *w* values.

M

```
M(:,:,1,1) [zeta=0.3, w=5] =
```

```
      25
-----
s^2 + 3 s + 25
```

```
M(:,:,2,1) [zeta=0.35, w=5] =
```

```
      25
-----
s^2 + 3.5 s + 25
```

...

For model arrays generated by linearizing a Simulink model at multiple parameter values or operating points, the software populates *SamplingGrid* automatically with the variable values that correspond to each entry in the array. For example, the Simulink Control Design commands *linearize* and *sLinearizer* populate *SamplingGrid* in this way.

Default: []

Examples

2-DOF PDF Controller

Create a continuous-time 2-DOF PDF controller in standard form. To do so, set the integral time constant to *Inf*. Set the other gains and the filter divisor to the desired values.

```
Kp = 1;
Ti = Inf;    % No integrator
Td = 3;
N = 6;
b = 0.5;    % setpoint weight on proportional term
c = 0.5;    % setpoint weight on derivative term
C2 = pidstd2(Kp,Ti,Td,N,b,c)
```

C2 =

$$u = K_p * [(b*r-y) + T_d * \frac{s}{(T_d/N)*s+1} * (c*r-y)]$$

with *Kp* = 1, *Td* = 3, *N* = 6, *b* = 0.5, *c* = 0.5

Continuous-time 2-DOF PDF controller in standard form

The display shows the controller type, formula, and parameter values, and verifies that the controller has no integrator term.

Discrete-Time 2-DOF PI Controller in Standard Form

Create a discrete-time 2-DOF PI controller in standard form, using the trapezoidal discretization formula. Specify the formula using `Name, Value` syntax.

```
Kp = 1;
Ti = 2.4;
Td = 0;
N = Inf;
b = 0.5;
c = 0;
Ts = 0.1;
C2 = pidstd2(Kp,Ti,Td,N,b,c,Ts,'IFormula','Trapezoidal')
```

C2 =

$$u = K_p * [(b*r-y) + \frac{1}{T_i} * \frac{T_s*(z+1)}{2*(z-1)} * (r-y)]$$

with $K_p = 1$, $T_i = 2.4$, $b = 0.5$, $T_s = 0.1$

Sample time: 0.1 seconds

Discrete-time 2-DOF PI controller in standard form

Setting $T_d = 0$ specifies a PI controller with no derivative term. As the display shows, the values of N and c are not used in this controller. The display also shows that the trapezoidal formula is used for the integrator.

2-DOF PID Controller with Named Inputs and Output

Create a 2-DOF PID controller in standard form, and set the dynamic system properties `InputName` and `OutputName`. Naming the inputs and the output is useful, for example, when you interconnect the PID controller with other dynamic system models using the `connect` command.

```
C2 = pidstd2(1,2,3,10,1,1,'InputName',{'r','y'},'OutputName','u')
```

C2 =

$$u = K_p * [(b*r-y) + \frac{1}{T_i} * \frac{1}{s} * (r-y) + T_d * \frac{s}{(T_d/N)*s+1} * (c*r-y)]$$

with $K_p = 1$, $T_i = 2$, $T_d = 3$, $N = 10$, $b = 1$, $c = 1$

Continuous-time 2-DOF PIDF controller in standard form

A 2-DOF PID controller has two inputs and one output. Therefore, the `'InputName'` property is an array containing two names, one for each input. The model display does not show the input and

output names for the PID controller, but you can examine the property values to see them. For instance, verify the input name of the controller.

C2.InputName

```
ans = 2x1 cell
      {'r'}
      {'y'}
```

Array of 2-DOF PID Controllers

Create a 2-by-3 grid of 2-DOF PI controllers in standard form. The proportional gain ranges from 1-2 across the array rows, and the integrator time constant ranges from 5-9 across columns.

To build the array of PID controllers, start with arrays representing the gains.

```
Kp = [1 1 1;2 2 2];
Ti = [5:2:9;5:2:9];
```

When you pass these arrays to the `pidstd2` command, the command returns the array of controllers.

```
pi_array = pidstd2(Kp,Ti,0,Inf,0.5,0,'Ts',0.1,'IFormula','BackwardEuler');
size(pi_array)
```

```
2x3 array of 2-DOF PID controller.
Each PID has 1 output and 2 inputs.
```

If you provide scalar values for some coefficients, `pidstd2` automatically expands them and assigns the same value to all entries in the array. For instance, in this example, $T_d = 0$, so that all entries in the array are PI controllers. Also, all entries in the array have $b = 0.5$.

Access entries in the array using array indexing. For dynamic system arrays, the first two dimensions are the I/O dimensions of the model, and the remaining dimensions are the array dimensions. Therefore, the following command extracts the (2,3) entry in the array.

```
pi23 = pi_array(:,:,2,3)
```

```
pi23 =
```

$$u = K_p * [(b*r-y) + \frac{1}{T_i} * \frac{T_s*z}{z-1} * (r-y)]$$

with $K_p = 2$, $T_i = 9$, $b = 0.5$, $T_s = 0.1$

```
Sample time: 0.1 seconds
Discrete-time 2-DOF PI controller in standard form
```

You can also build an array of PID controllers using the `stack` command.

```
C2 = pidstd2(1,5,0.1,Inf,0.5,0.5);           % PID controller
C2f = pidstd2(1,5,0.1,0.5,0.5,0.5);        % PID controller with filter
pid_array = stack(2,C2,C2f);                % stack along 2nd array dimension
```

These commands return a 1-by-2 array of controllers.

```
size(pid_array)
```

1x2 array of 2-DOF PID controller.
Each PID has 1 output and 2 inputs.

All PID controllers in an array must have the same sample time, discrete integrator formulas, and dynamic system properties such as `InputName` and `OutputName`.

Convert 2-DOF PID Controller from Parallel to Standard Form

Convert a parallel-form `pid2` controller to standard form.

Parallel PID form expresses the controller actions in terms of proportional, integral, and derivative gains K_p , K_i , and K_d , and filter time constant T_f . You can convert a parallel-form `pid2` controller to standard form using the `pidstd2` command, provided that both of the following are true:

- The `pid2` controller can be expressed in valid standard form.
- The gains K_p , K_i , and K_d of the `pid2` controller all have the same sign.

For example, consider the following parallel-form controller.

```
Kp = 2;
Ki = 3;
Kd = 4;
Tf = 2;
b = 0.1;
c = 0.5;
C2_par = pid2(Kp,Ki,Kd,Tf,b,c)
```

```
C2_par =
```

$$u = K_p (b*r-y) + K_i \frac{1}{s} (r-y) + K_d \frac{s}{T_f*s+1} (c*r-y)$$

with $K_p = 2$, $K_i = 3$, $K_d = 4$, $T_f = 2$, $b = 0.1$, $c = 0.5$

Continuous-time 2-DOF PIDF controller in parallel form.

Convert this controller to parallel form using `pidstd2`.

```
C2_std = pidstd2(C2_par)
```

```
C2_std =
```

$$u = K_p * [(b*r-y) + \frac{1}{T_i} * \frac{1}{s} * (r-y) + T_d * \frac{s}{(T_d/N)*s+1} * (c*r-y)]$$

with $K_p = 2$, $T_i = 0.667$, $T_d = 2$, $N = 1$, $b = 0.1$, $c = 0.5$

Continuous-time 2-DOF PIDF controller in standard form

The display confirms the new standard form. A response plot confirms that the two forms are equivalent.

```
bodeplot(C2_par,'b-',C2_std,'r--')
legend('Parallel','Standard','Location','Southeast')
```

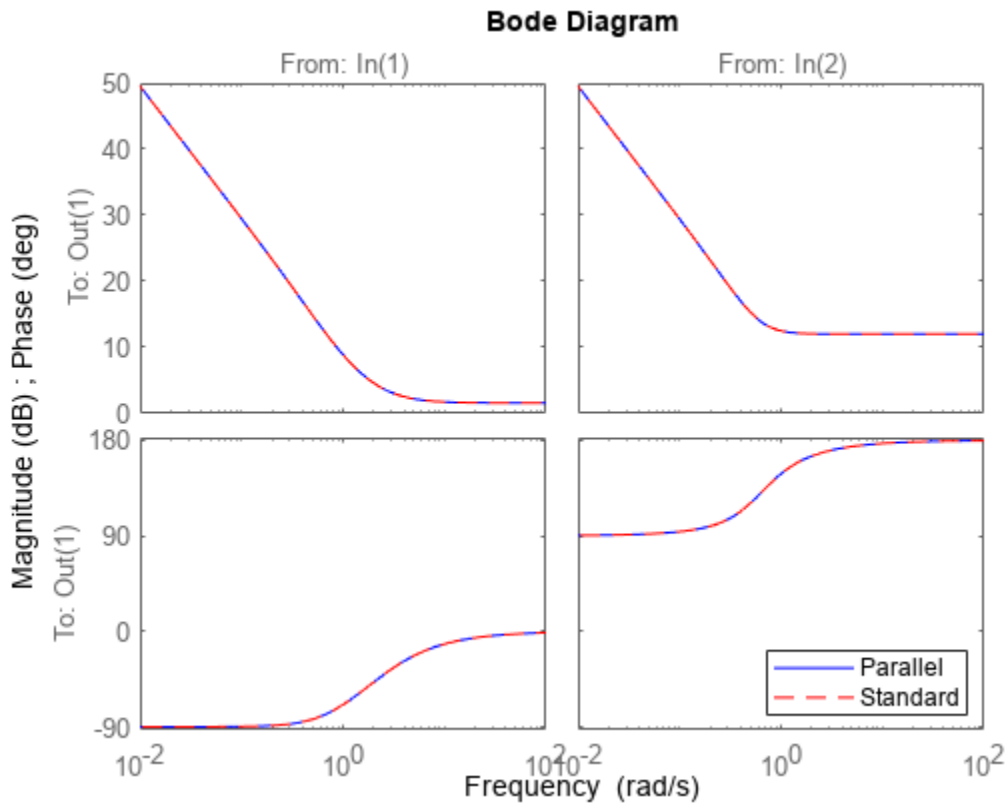

Convert Dynamic System to Standard-Form 2-DOF PID Controller

Convert a two-input, one-output continuous-time dynamic system that represents a 2-DOF PID controller to a standard-form `pidstd2` controller.

The following state-space matrices represent a 2-DOF PID controller.

```
A = [0,0;0,-8.181];
B = [1,-1;-0.1109,8.181];
C = [0.2301,10.66];
D = [0.8905,-11.79];
sys = ss(A,B,C,D);
```

Rewrite `sys` in terms of the standard-form PID parameters K_p , T_i , T_d , and N , and the setpoint weights b and c .

```
C2 = pidstd2(sys)
```

C2 =

$$u = K_p * [(b*r-y) + \frac{1}{T_i} * \frac{1}{s} * (r-y) + T_d * \frac{s}{s^2} * (c*r-y)]$$

$$T_i \quad s \quad (T_d/N)*s+1$$

with $K_p = 1.13$, $T_i = 4.91$, $T_d = 1.15$, $N = 9.43$, $b = 0.66$, $c = 0.0136$

Continuous-time 2-DOF PIDF controller in standard form

Convert Discrete-Time Dynamic System to 2-DOF Standard-Form PID Controller

Convert a discrete-time dynamic system that represents a 2-DOF PID controller with derivative filter to standard pidstd2 form.

The following state-space matrices represent a discrete-time 2-DOF PID controller with a sample time of 0.05 s.

```
A = [1,0;0,0.6643];
B = [0.05,-0.05; -0.004553,0.3357];
C = [0.2301,10.66];
D = [0.8905,-11.79];
Ts = 0.05;
sys = ss(A,B,C,D,Ts);
```

When you convert `sys` to 2-DOF PID form, the result depends on which discrete integrator formulas you specify for the conversion. For instance, use the default, `ForwardEuler`, for both the integrator and the derivative.

```
C2fe = pidstd2(sys)
```

```
C2fe =
```

$$u = K_p * [(b*r-y) + \frac{1}{T_i} * \frac{T_s}{z-1} * (r-y) + T_d * \frac{1}{(T_d/N)+T_s/(z-1)} * (c*r-y)]$$

with $K_p = 1.13$, $T_i = 4.91$, $T_d = 1.41$, $N = 9.43$, $b = 0.66$, $c = 0.0136$, $T_s = 0.05$

Sample time: 0.05 seconds

Discrete-time 2-DOF PIDF controller in standard form

Now convert using the Trapezoidal formula.

```
C2trap = pidstd2(sys, 'IFormula', 'Trapezoidal', 'DFormula', 'Trapezoidal')
```

```
C2trap =
```

$$u = K_p * [(b*r-y) + \frac{1}{T_i} * \frac{T_s*(z+1)}{2*(z-1)} * (r-y) + T_d * \frac{1}{(T_d/N)+T_s/2*(z+1)/(z-1)} * (c*r-y)]$$

with $K_p = 1.12$, $T_i = 4.89$, $T_d = 1.41$, $N = 11.4$, $b = 0.658$, $c = 0.0136$, $T_s = 0.05$

Sample time: 0.05 seconds

Discrete-time 2-DOF PIDF controller in standard form

The displays show the difference in resulting coefficient values and functional form.

For some dynamic systems, attempting to use the Trapezoidal or BackwardEuler integrator formulas yields invalid results, such as negative T_i , T_d , or N values. In such cases, `pidstd2` returns an error.

Discretize a Standard-Form 2-DOF PID Controller

Discretize a continuous-time standard-form 2-DOF PID controller and specify the integral and derivative filter formulas.

Create a continuous-time `pidstd2` controller and discretize it using the zero-order-hold method of the `c2d` command.

```
C2con = pidstd2(10,5,3,0.5,1,1); % continuous-time 2-DOF PIDF controller
C2dis1 = c2d(C2con,0.1,'zoh')
```

```
C2dis1 =
```

$$u = K_p * [(b*r-y) + \frac{1}{T_i} * \frac{T_s}{z-1} * (r-y) + T_d * \frac{1}{(T_d/N)+T_s/(z-1)} * (c*r-y)]$$

```
with Kp = 10, Ti = 5, Td = 3.03, N = 0.5, b = 1, c = 1, Ts = 0.1
```

```
Sample time: 0.1 seconds
```

```
Discrete-time 2-DOF PIDF controller in standard form
```

The display shows that `c2d` computes new PID coefficients for the discrete-time controller.

The discrete integrator formulas of the discretized controller depend on the `c2d` discretization method, as described in “Tips” on page 2-973. For the `zoh` method, both `IFormula` and `DFormula` are `ForwardEuler`.

```
C2dis1.IFormula
```

```
ans =
'ForwardEuler'
```

```
C2dis1.DFormula
```

```
ans =
'ForwardEuler'
```

If you want to use different formulas from the ones returned by `c2d`, then you can directly set the `Ts`, `IFormula`, and `DFormula` properties of the controller to the desired values.

```
C2dis2 = C2con;
C2dis2.Ts = 0.1;
C2dis2.IFormula = 'BackwardEuler';
C2dis2.DFormula = 'BackwardEuler';
```

However, these commands do not compute new coefficients for the discretized controller. To see this, examine `C2dis2` and compare the coefficients to `C2con` and `C2dis1`.

```
C2dis2
```

C2dis2 =

$$u = K_p * [(b*r-y) + \frac{1}{T_i} * \frac{T_s*z}{z-1} * (r-y) + T_d * \frac{1}{(T_d/N)+T_s*z/(z-1)} * (c*r-y)]$$

with $K_p = 10$, $T_i = 5$, $T_d = 3$, $N = 0.5$, $b = 1$, $c = 1$, $T_s = 0.1$

Sample time: 0.1 seconds

Discrete-time 2-DOF PIDF controller in standard form

Tips

- To design a PID controller for a particular plant, use `pidtune` or `pidTuner`. To create a tunable 2-DOF PID controller as a control design block, use `tunablePID2`.
- To break a 2-DOF controller into two SISO control components, such as a feedback controller and a feedforward controller, use `getComponents`.
- Create arrays of `pidstd2` controllers by:
 - Specifying array values for one or more of the coefficients K_p , T_i , T_d , N , b , and c .
 - Specifying an array of dynamic systems `sys` to convert to `pid2` controller objects.
 - Using `stack` to build arrays from individual controllers or smaller arrays.
 - Passing an array of plant models to `pidtune`.

In an array of `pidstd2` controllers, each controller must have the same sample time T_s and discrete integrator formulas `IFormula` and `DFormula`.

- To create or convert to a parallel-form controller, use `pid2`. Parallel form expresses the controller actions in terms of proportional, integral, and derivative gains K_p , K_i and K_d , and a filter time constant T_f . For example, the relationship between the inputs and output of a continuous-time parallel-form 2-DOF PID controller is given by:

$$u = K_p(br - y) + \frac{K_i}{s}(r - y) + \frac{K_d s}{T_f s + 1}(cr - y).$$

- There are two ways to discretize a continuous-time `pidstd2` controller:
 - Use the `c2d` command. `c2d` computes new parameter values for the discretized controller. The discrete integrator formulas of the discretized controller depend upon the `c2d` discretization method you use, as shown in the following table.

c2d Discretization Method	IFormula	DFormula
'zoh'	ForwardEuler	ForwardEuler
'foh'	Trapezoidal	Trapezoidal
'tustin'	Trapezoidal	Trapezoidal
'impulse'	ForwardEuler	ForwardEuler
'matched'	ForwardEuler	ForwardEuler

For more information about `c2d` discretization methods, See the `c2d` reference page. For more information about `IFormula` and `DFormula`, see “Properties” on page 2-961 .

- If you require different discrete integrator formulas, you can discretize the controller by directly setting `Ts`, `IFormula`, and `DFormula` to the desired values. (See “Discretize a Standard-Form 2-DOF PID Controller” on page 2-972.) However, this method does not compute new gain and filter-constant values for the discretized controller. Therefore, this method might yield a poorer match between the continuous- and discrete-time `pidstd2` controllers than using `c2d`.

Version History

Introduced in R2015b

See Also

`pid2` | `pidstddata2` | `pidtune` | `pidTuner` | `getComponents`

Topics

“Two-Degree-of-Freedom PID Controllers”

“Discrete-Time Proportional-Integral-Derivative (PID) Controllers”

“What Are Model Objects?”

pidstddata

Access coefficients of standard-form PID controller

Syntax

```
[Kp,Ti,Td,N] = pidstddata(sys)
[Kp,Ti,Td,N,Ts] = pidstddata(sys)
[Kp,Ti,Td,N,Ts] = pidstddata(sys, J1,...,JN)
```

Description

`[Kp,Ti,Td,N] = pidstddata(sys)` returns the proportional gain `Kp`, integral time `Ti`, derivative time `Td`, and filter divisor `N` of the standard-form controller represented by the dynamic system `sys`.

`[Kp,Ti,Td,N,Ts] = pidstddata(sys)` also returns the sample time `Ts`.

`[Kp,Ti,Td,N,Ts] = pidstddata(sys, J1,...,JN)` extracts the data for a subset of entries in the array of `sys` dynamic systems. The indices `J` specify the array entries to extract.

Input Arguments

`sys`

SISO dynamic system or array of SISO dynamic systems. If `sys` is not a `pidstd` object, it must represent a valid PID controller that can be written in standard PID form.

`J`

Integer indices of `N` entries in the array `sys` of dynamic systems.

Output Arguments

`Kp`

Proportional gain of the standard-form PID controller represented by dynamic system `sys`.

If `sys` is a `pidstd` controller object, the output `Kp` is equal to the `Kp` value of `sys`.

If `sys` is not a `pidstd` object, `Kp` is the proportional gain of a standard-form PID controller equivalent to `sys`.

If `sys` is an array of dynamic systems, `Kp` is an array of the same dimensions as `sys`.

`Ti`

Integral time constant of the standard-form PID controller represented by dynamic system `sys`.

If `sys` is a `pidstd` controller object, the output `Ti` is equal to the `Ti` value of `sys`.

If `sys` is not a `pidstd` object, `Ti` is the integral time constant of a standard-form PID controller equivalent to `sys`.

If `sys` is an array of dynamic systems, `Ti` is an array of the same dimensions as `sys`.

Td

Derivative time constant of the standard-form PID controller represented by dynamic system `sys`.

If `sys` is a `pidstd` controller object, the output `Td` is equal to the `Td` value of `sys`.

If `sys` is not a `pidstd` object, `Td` is the derivative time constant of a standard-form PID controller equivalent to `sys`.

If `sys` is an array of dynamic systems, `Td` is an array of the same dimensions as `sys`.

N

Filter divisor of the standard-form PID controller represented by dynamic system `sys`.

If `sys` is a `pidstd` controller object, the output `N` is equal to the `N` value of `sys`.

If `sys` is not a `pidstd` object, `N` is the filter time constant of a standard-form PID controller equivalent to `sys`.

If `sys` is an array of dynamic systems, `N` is an array of the same dimensions as `sys`.

Ts

Sample time of the dynamic system `sys`. `Ts` is always a scalar value.

Examples

Extract the proportional, integral, and derivative gains and the filter time constant from a standard-form `pidstd` controller.

For the following `pidstd` object:

```
sys = pidstd(1,4,0.3,10);
```

you can extract the parameter values from `sys` by entering:

```
[Kp Ti Td N] = pidstddata(sys);
```

Extract the standard-form proportional and integral gains from an equivalent parallel-form PI controller.

For a standard-form PI controller, such as:

```
sys = pid(2,3);
```

you can extract the gains of an equivalent parallel-form PI controller by entering:

```
[Kp Ti] = pidstddata(sys)
```

These commands return the result:

```
Kp =
```

```
2
```

```
Ti =
    0.6667
```

Extract parameters from a dynamic system that represents a PID controller.

The dynamic system

$$H(z) = \frac{(z - 0.5)(z - 0.6)}{(z - 1)(z + 0.8)}$$

represents a discrete-time PID controller with a derivative filter. Use `pidstddata` to extract the standard-form PID parameters.

```
H = zpks([0.5 0.6],[1,-0.8],1,0.1); % sample time Ts = 0.1s
[Kp Ti Td N Ts] = pidstddata(H);
```

the `pidstddata` function uses the default `ForwardEuler` discrete integrator formula for `Iformula` and `Dformula` to compute the parameter values.

Extract the gains from an array of PI controllers.

```
sys = pidstd(rand(2,3),rand(2,3)); % 2-by-3 array of PI controllers
[Kp Ti Td N] = pidstddata(sys);
```

The parameters `Kp`, `Ti`, `Td`, and `N` are also 2-by-3 arrays.

Use the index input `J` to extract the parameters of a subset of `sys`.

```
[Kp Ti Td N] = pidstddata(sys,5);
```

Tips

If `sys` is not a `pidstd` controller object, `pidstddata` returns `Kp`, `Ti`, `Td` and `N` values of a standard-form controller equivalent to `sys`.

For discrete-time `sys`, `piddata` returns parameters of an equivalent `pidstd` controller. This controller has discrete integrator formulas `Iformula` and `Dformula` set to `ForwardEuler`. See the `pidstd` reference page for more information about discrete integrator formulas.

Version History

Introduced in R2010b

See Also

`pidstd` | `pid` | `get`

pidstddata2

Access coefficients of standard-form 2-DOF PID controller

Syntax

```
[Kp,Ti,Td,N,b,c] = pidstddata2(sys)
[Kp,Ti,Td,N,b,c,Ts] = pidstddata2(sys)
[Kp,Ti,Td,N,b,c,Ts] = pidstddata2(sys,J1,...,JN)
```

Description

`[Kp,Ti,Td,N,b,c] = pidstddata2(sys)` returns the proportional gain `Kp`, integral time `Ti`, derivative time `Td`, the filter divisor `N`, and the setpoint weights `b` and `c` of the standard-form 2-DOF PID controller represented by the dynamic system `sys`.

If `sys` is a `pidstd2` controller object, then each output argument is the corresponding coefficient in `sys`.

If `sys` is not a `pidstd2` object, then each output argument is the corresponding coefficient of the standard-form 2-DOF PID controller that is equivalent to `sys`.

If `sys` is an array of dynamic systems, then each output argument is an array of the same dimensions as `sys`.

`[Kp,Ti,Td,N,b,c,Ts] = pidstddata2(sys)` also returns the sample time `Ts`. For discrete-time `sys` that is not a `pidstd2` object, `pidstddata2` calculates the coefficient values using the default ForwardEuler discrete integrator formula for both `IFormula` and `DFormula`. See the `pidstd2` reference page for more information about discrete integrator formulas.

`[Kp,Ti,Td,N,b,c,Ts] = pidstddata2(sys,J1,...,JN)` extracts the data for a subset of entries in `sys`, where `sys` is an N-dimensional array of dynamic systems. The indices `J` specify the array entry to extract.

Examples

Extract Coefficients from Standard-Form 2-DOF PID Controller

Typically, you extract coefficients from a controller obtained from another function, such as `pidtune` or `getBlockValue`. For this example, create a standard-form 2-DOF PID controller that has random coefficients.

```
rng('default'); % for reproducibility
C2 = pidstd2(rand,rand,rand,rand,rand,rand);
```

Extract the PID coefficients, filter divisor, and setpoint weights.

```
[Kp,Ti,Td,N,b,c] = pidstddata2(C2);
```

Extract Standard-Form Coefficients from Parallel-Form Controller

Create a 2-DOF PID controller in parallel form.

```
C2 = pid2(2,3,4,10,0.5,0.5)
```

```
C2 =
```

$$u = K_p (b*r-y) + K_i \frac{1}{s} (r-y) + K_d \frac{s}{T_f*s+1} (c*r-y)$$

with $K_p = 2$, $K_i = 3$, $K_d = 4$, $T_f = 10$, $b = 0.5$, $c = 0.5$

Continuous-time 2-DOF PIDF controller in parallel form.

Compute the coefficients of an equivalent parallel-form PID controller.

```
[Kp,Ti,Td,N,b,c] = pidstddata2(C2);
```

Check some of the coefficients to confirm that they are different from the parallel-form coefficients.

```
Ti
```

```
Ti = 0.6667
```

```
Td
```

```
Td = 2
```

Extract Standard-Form 2-DOF PID Coefficients from Equivalent System

Extract coefficients from a two-input, one-output dynamic system that represents a valid 2-DOF standard-form PID controller.

The following A, B, C, and D matrices form a discrete-time state-space model that represents a 2-DOF PID controller in standard form.

```
A = [1,0;0,0.5];
B = [0.1,-0.1;-0.25,0.5];
C = [4,400];
D = [220,-440];
sys = ss(A,B,C,D,0.1)
```

```
sys =
```

```
A =
      x1    x2
x1      1      0
x2      0    0.5
```

```
B =
      u1    u2
x1     0.1   -0.1
x2   -0.25    0.5
```

```

C =
      x1   x2
y1    4  400

D =
      u1   u2
y1   220 -440

```

Sample time: 0.1 seconds
Discrete-time state-space model.

Extract the PID coefficients, filter divisor, and setpoint weights of the model.

```
[Kp,Ti,Td,N,b,c,Ts] = pidstddata2(sys);
```

For a discrete-time system, `pidstddata2` calculates the coefficient values using the default ForwardEuler discrete integrator formula for both IFormula and DFormula.

Extract Standard-Form Coefficients from 2-DOF PI Controller Array

Typically, you obtain an array of controllers by using `pidtune` on an array of plant models. For this example, create a 2-by-3 array of standard-form 2-DOF PI controllers with random values of K_p , T_i , and b .

```
rng('default');
C2 = pidstd2(rand(2,3),rand(2,3),0,10,rand(2,3),0);
```

Extract all the coefficients from the array.

```
[Kp,Ti,Td,N,b,c] = pidstddata2(C2);
```

Each of the outputs is itself a 2-by-3 array. For example, examine K_i .

T_i

```
Ti = 2x3
    0.2785    0.9575    0.1576
    0.5469    0.9649    0.9706
```

Extract only the coefficients of entry (2,1) in the array.

```
[Kp21,Ti21,Td21,N21,b21,c21] = pidstddata2(C2,2,1);
```

Each of these outputs is a scalar.

T_{i21}

```
Ti21 = 0.5469
```

Input Arguments

sys — 2-DOF PID controller

`pidstd2` controller object | dynamic system model | dynamic system array

2-DOF PID controller in standard form, specified as a `pidstd2` controller object, a dynamic system model, or a dynamic system array. If `sys` is not a `pidstd2` controller object, it must be a two-input, one-output model that represents a valid 2-DOF PID controller that can be written in standard form.

J – Indices

positive integers

Indices of entry to extract from a model array `sys`, specified as positive integers. Provide as many indices as there are array dimensions in `sys`. For example, suppose `sys` is a 4-by-5 (two-dimensional) array of `pidstd2` controllers or dynamic system models that represent 2-DOF PID controllers. The following command extracts the data for entry (2,3) in the array.

```
[Kp,Ti,Td,N,b,c,Ts] = pidstdata2(sys,2,3);
```

Output Arguments

Kp – Proportional gain

scalar | array

Proportional gain of the standard-form 2-DOF PID controller represented by `sys`, returned as a scalar or array.

If `sys` is a `pidstd2` controller object, then `Kp` is the `Kp` value of `sys`.

If `sys` is not a `pidstd2` object, then `Kp` is the proportional gain of the standard-form 2-DOF PID controller that is equivalent to `sys`.

If `sys` is an array of dynamic systems, then `Kp` is an array of the same dimensions as `sys`.

Ti – Integral time constant

scalar | array

Integral time constant of the standard-form 2-DOF PID controller represented by `sys`, returned as a scalar or array.

Td – Derivative time constant

scalar | array

Derivative time constant of the standard-form 2-DOF PID controller represented by `sys`, returned as a scalar or array.

N – Filter divisor

scalar | array

Filter divisor of the parallel-form 2-DOF PID controller represented by `sys`, returned as a scalar or array.

b – Setpoint weight on proportional term

scalar | array

Setpoint weight on the proportional term of the standard-form 2-DOF PID controller represented by `sys`, returned as a scalar or array.

c – Setpoint weight on derivative term

scalar | array

Setpoint weight on the derivative term of the standard-form 2-DOF PID controller represented by `sys`, returned as a scalar or array.

Ts — Sample time

scalar

Sample time of the `pidstd2` controller, dynamic system `sys`, or dynamic system array, returned as a scalar.

Version History

Introduced in R2015b

See Also

`pidstd2` | `piddata2` | `pidstddata`

pidtool

Open PID Tuner for PID tuning

Note pidtool has been removed. Use pidTuner instead.

Version History

Introduced in R2010b

pidtune

PID tuning algorithm for linear plant model

Syntax

```
C = pidtune(sys,type)
C = pidtune(sys,C0)
C = pidtune(sys,type,wc)
C = pidtune(sys,C0,wc)
C = pidtune(sys,...,opts)
[C,info] = pidtune(...)
```

Description

`C = pidtune(sys,type)` designs a PID controller of type `type` for the plant `sys`. If `type` specifies a one-degree-of-freedom (1-DOF) PID controller, then the controller is designed for the unit feedback loop as illustrated:

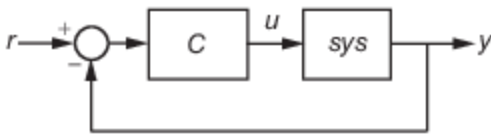

If `type` specifies a two-degree-of-freedom (2-DOF) PID controller, then `pidtune` designs a 2-DOF controller as in the feedback loop of this illustration:

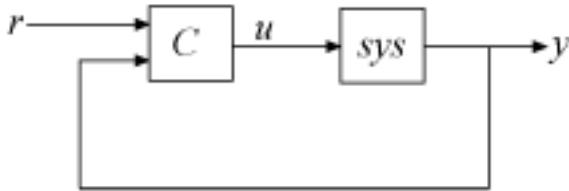

`pidtune` tunes the parameters of the PID controller `C` to balance performance (response time) and robustness (stability margins).

`C = pidtune(sys,C0)` designs a controller of the same type and form as the controller `C0`. If `sys` and `C0` are discrete-time models, `C` has the same discrete integrator formulas as `C0`.

`C = pidtune(sys,type,wc)` and `C = pidtune(sys,C0,wc)` specify a target value `wc` for the first 0 dB gain crossover frequency of the open-loop response.

`C = pidtune(sys,...,opts)` uses additional tuning options, such as the target phase margin. Use `pidtuneOptions` to specify the option set `opts`.

`[C,info] = pidtune(...)` returns the data structure `info`, which contains information about closed-loop stability, the selected open-loop gain crossover frequency, and the actual phase margin.

Input Arguments

sys

Single-input, single-output dynamic system model of the plant for controller design. `sys` can be:

- Any type of SISO dynamic system model, including Numeric LTI models and identified models. If `sys` is a tunable or uncertain model, `pidtune` designs a controller for the current or nominal value of `sys`.
- A continuous- or discrete-time model.
- Stable, unstable, or integrating. A plant with unstable poles, however, might not be stabilizable under PID control.
- A model that includes any type of time delay. A plant with long time delays, however, might not achieve adequate performance under PID control.
- An array of plant models. If `sys` is an array, `pidtune` designs a separate controller for each plant in the array.

If the plant has unstable poles, and `sys` is one of the following:

- A `frd` model
- A `ss` model with internal time delays that cannot be converted to I/O delays

you must use `pidtuneOptions` to specify the number of unstable poles in the plant, if any.

type

Controller type of the controller to design, specified as a character vector. The term controller type refers to which terms are present in the controller action. For example, a PI controller has only a proportional and an integral term, while a PIDF controller contains proportional, integrator, and filtered derivative terms. `type` can take the values summarized below. For more detailed information about these controller types, see “PID Controller Types for Tuning”

1-DOF Controllers

- 'P' — Proportional only
- 'I' — Integral only
- 'PI' — Proportional and integral
- 'PD' — Proportional and derivative
- 'PDF' — Proportional and derivative with first-order filter on derivative term
- 'PID' — Proportional, integral, and derivative
- 'PIDF' — Proportional, integral, and derivative with first-order filter on derivative term

2-DOF Controllers

- 'PI2' — 2-DOF proportional and integral
- 'PD2' — 2-DOF proportional and derivative
- 'PDF2' — 2-DOF proportional and derivative with first-order filter on derivative term
- 'PID2' — 2-DOF proportional, integral, and derivative
- 'PIDF2' — 2-DOF proportional, integral, and derivative with first-order filter on derivative term

For more information about 2-DOF PID controllers generally, see “Two-Degree-of-Freedom PID Controllers”.

2-DOF Controllers with Fixed Setpoint Weights

- 'I-PD' — 2-DOF PID with $b = 0$, $c = 0$
- 'I-PDF' — 2-DOF PIDF with $b = 0$, $c = 0$
- 'ID-P' — 2-DOF PID with $b = 0$, $c = 1$
- 'IDF-P' — 2-DOF PIDF with $b = 0$, $c = 1$
- 'PI-D' — 2-DOF PID with $b = 1$, $c = 0$
- 'PI-DF' — 2-DOF PIDF with $b = 1$, $c = 0$

For more detailed information about fixed-setpoint-weight 2-DOF PID controllers, see “PID Controller Types for Tuning”.

Controller Form

When you use the `type` input, `pidtune` designs a controller in parallel (`pid` or `pid2`) form. Use the input `C0` instead of `type` if you want to design a controller in standard (`pidstd` or `pidstd2`) form.

If `sys` is a discrete-time model with sample time T_s , `pidtune` designs a discrete-time controller with the same T_s . The controller has the `ForwardEuler` discrete integrator formula for both integral and derivative actions. Use the input `C0` instead of `type` if you want to design a controller having a different discrete integrator formula.

For more information about PID controller forms and formulas, see:

- “Proportional-Integral-Derivative (PID) Controllers”
- “Two-Degree-of-Freedom PID Controllers”
- “Discrete-Time Proportional-Integral-Derivative (PID) Controllers”

C0

PID controller setting properties of the designed controller, specified as a `pid`, `pidstd`, `pid2`, or `pidstd2` object. If you provide `C0`, `pidtune`:

- Designs a controller of the type represented by `C0`.
- Returns a `pid` controller, if `C0` is a `pid` controller.
- Returns a `pidstd` controller, if `C0` is a `pidstd` controller.
- Returns a 2-DOF `pid2` controller, if `C0` is a `pid2` controller.
- Returns a 2-DOF `pidstd2` controller, if `C0` is a `pidstd2` controller.
- Returns a controller with the same `Iformula` and `Dformula` values as `C0`, if `sys` is a discrete-time system. See the `pid`, `pid2`, `pidstd`, and `pidstd2` reference pages for more information about `Iformula` and `Dformula`.

wc

Target value for the 0 dB gain crossover frequency of the tuned open-loop response. Specify `wc` in units of radians/`TimeUnit`, where `TimeUnit` is the time unit of `sys`. The crossover frequency `wc` roughly sets the control bandwidth. The closed-loop response time is approximately $1/wc$.

Increase `wc` to speed up the response. Decrease `wc` to improve stability. When you omit `wc`, `pidtune` automatically chooses a value, based on the plant dynamics, that achieves a balance between response and stability.

opts

Option set specifying additional tuning options for the `pidtune` design algorithm, such as target phase margin or design focus. Use `pidtuneOptions` to create `opts`.

Output Arguments

C

Controller designed for `sys`. If `sys` is an array of linear models, `pidtune` designs a controller for each linear model and returns an array of PID controllers.

Controller form:

- If the second argument to `pidtune` is `type`, `C` is a `pid` or `pid2` controller.
- If the second argument to `pidtune` is `C0`:
 - `C` is a `pid` controller, if `C0` is a `pid` object.
 - `C` is a `pidstd` controller, if `C0` is a `pidstd` object.
 - `C` is a `pid2` controller, if `C0` is a `pid2` object.
 - `C` is a `pidstd2` controller, if `C0` is a `pidstd2` object.

Controller type:

- If the second argument to `pidtune` is `type`, `C` generally has the specified type.
- If the second argument to `pidtune` is `C0`, `C` generally has the same type as `C0`.

In either case, however, where the algorithm can achieve adequate performance and robustness using a lower-order controller than specified with `type` or `C0`, `pidtune` returns a `C` having fewer actions than specified. For example, `C` can be a PI controller even though `type` is `'PIDF'`.

Time domain:

- `C` has the same time domain as `sys`.
- If `sys` is a discrete-time model, `C` has the same sample time as `sys`.
- If you specify `C0`, `C` has the same `Iformula` and `Dformula` as `C0`. If no `C0` is specified, both `Iformula` and `Dformula` are Forward Euler. See the `pid`, `pid2`, `pidstd`, and `pidstd2` reference pages for more information about `Iformula` and `Dformula`.

If you specify `C0`, `C` also obtains model properties such as `InputName` and `OutputName` from `C0`. For more information about model properties, see the reference pages for each type of dynamic system model.

info

Data structure containing information about performance and robustness of the tuned PID loop. The fields of `info` are:

- **Stable** — Boolean value indicating closed-loop stability. **Stable** is 1 if the closed loop is stable, and 0 otherwise.
- **CrossoverFrequency** — First 0 dB crossover frequency of the open-loop system $C*sys$, in rad/TimeUnit, where TimeUnit is the time units specified in the TimeUnit property of sys.
- **PhaseMargin** — Phase margin of the tuned PID loop, in degrees.

If **sys** is an array of plant models, **info** is an array of data structures containing information about each tuned PID loop.

Examples

PID Controller Design at the Command Line

This example shows how to design a PID controller for the plant given by:

$$sys = \frac{1}{(s + 1)^3}.$$

As a first pass, create a model of the plant and design a simple PI controller for it.

```
sys = zpk([], [-1 -1 -1], 1);
[C_pi, info] = pidtune(sys, 'PI')
```

`C_pi =`

$$K_p + K_i * \frac{1}{s}$$

with $K_p = 1.14$, $K_i = 0.454$

Continuous-time PI controller in parallel form.

```
info = struct with fields:
    Stable: 1
    CrossoverFrequency: 0.5205
    PhaseMargin: 60.0000
```

`C_pi` is a `pid` controller object that represents a PI controller. The fields of `info` show that the tuning algorithm chooses an open-loop crossover frequency of about 0.52 rad/s.

Examine the closed-loop step response (reference tracking) of the controlled system.

```
T_pi = feedback(C_pi*sys, 1);
step(T_pi)
```

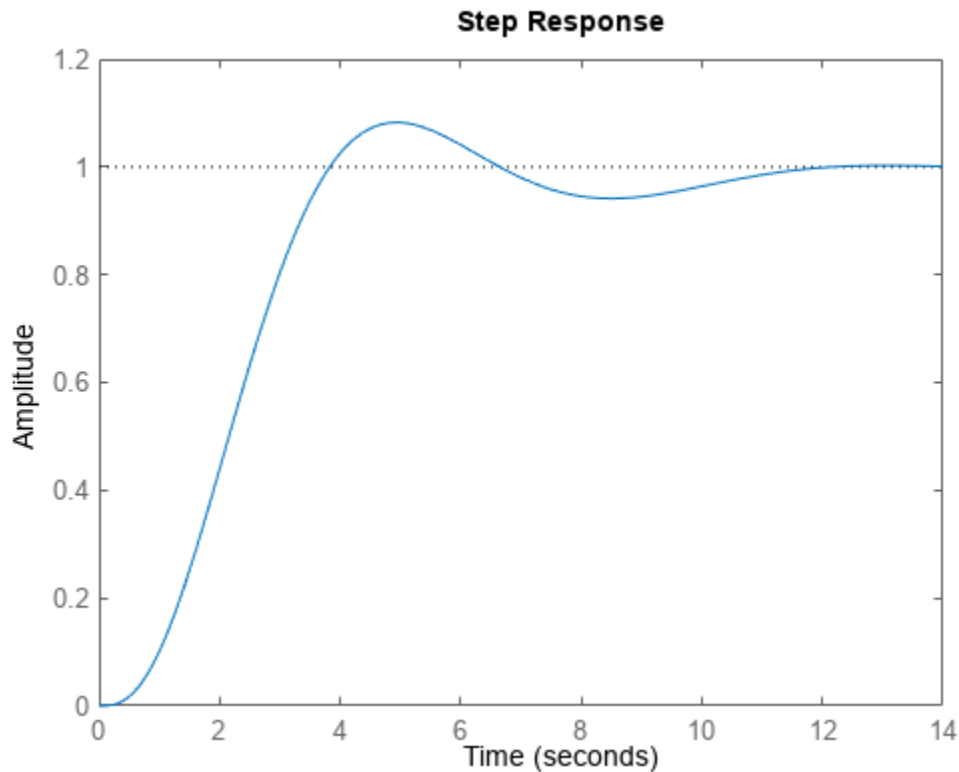

To improve the response time, you can set a higher target crossover frequency than the result that `pidtune` automatically selects, 0.52. Increase the crossover frequency to 1.0.

```
[C_pi_fast,info] = pidtune(sys,'PI',1.0)
```

```
C_pi_fast =
```

$$K_p + K_i * \frac{1}{s}$$

```
with Kp = 2.83, Ki = 0.0495
```

```
Continuous-time PI controller in parallel form.
```

```
info = struct with fields:
```

```
    Stable: 1
  CrossoverFrequency: 1
    PhaseMargin: 43.9973
```

The new controller achieves the higher crossover frequency, but at the cost of a reduced phase margin.

Compare the closed-loop step response with the two controllers.

```
T_pi_fast = feedback(C_pi_fast*sys,1);
step(T_pi,T_pi_fast)
```

```
axis([0 30 0 1.4])
legend('PI', 'PI,fast')
```

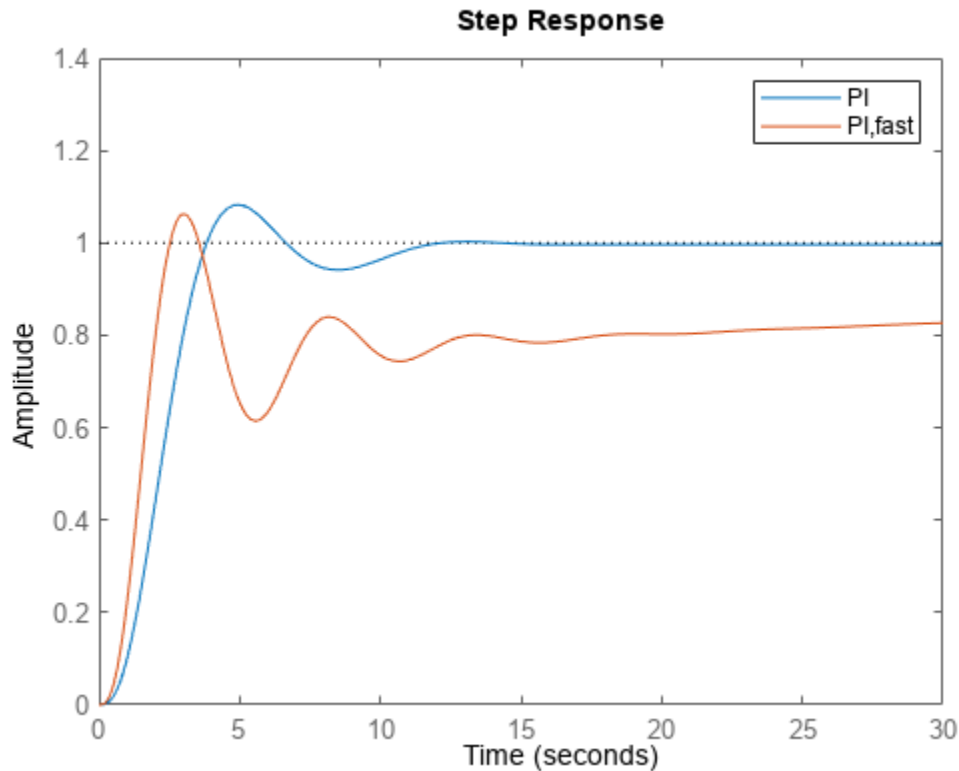

This reduction in performance results because the PI controller does not have enough degrees of freedom to achieve a good phase margin at a crossover frequency of 1.0 rad/s. Adding a derivative action improves the response.

Design a PIDF controller for G_c with the target crossover frequency of 1.0 rad/s.

```
[C_pidf_fast,info] = pidtune(sys, 'PIDF', 1.0)
```

```
C_pidf_fast =
```

$$K_p + K_i * \frac{1}{s} + K_d * \frac{s}{T_f s + 1}$$

with $K_p = 2.72$, $K_i = 0.985$, $K_d = 1.72$, $T_f = 0.00875$

Continuous-time PIDF controller in parallel form.

```
info = struct with fields:
    Stable: 1
    CrossoverFrequency: 1
    PhaseMargin: 60.0000
```

The fields of info show that the derivative action in the controller allows the tuning algorithm to design a more aggressive controller that achieves the target crossover frequency with a good phase margin.

Compare the closed-loop step response and disturbance rejection for the fast PI and PIDF controllers.

```
T_pidf_fast = feedback(C_pidf_fast*sys,1);
step(T_pi_fast, T_pidf_fast);
axis([0 30 0 1.4]);
legend('PI,fast', 'PIDF,fast');
```

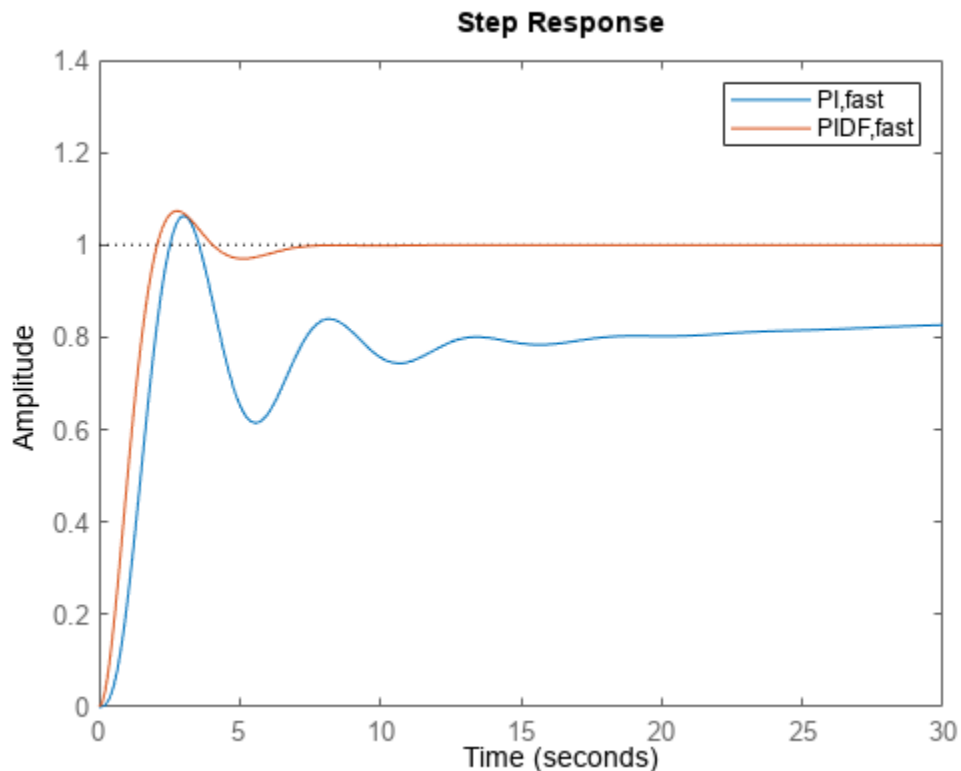

You can compare the input (load) disturbance rejection of the controlled system with the fast PI and PIDF controllers. To do so, plot the response of the closed-loop transfer function from the plant input to the plant output.

```
S_pi_fast = feedback(sys,C_pi_fast);
S_pidf_fast = feedback(sys,C_pidf_fast);
step(S_pi_fast,S_pidf_fast);
axis([0 50 0 0.4]);
legend('PI,fast', 'PIDF,fast');
```

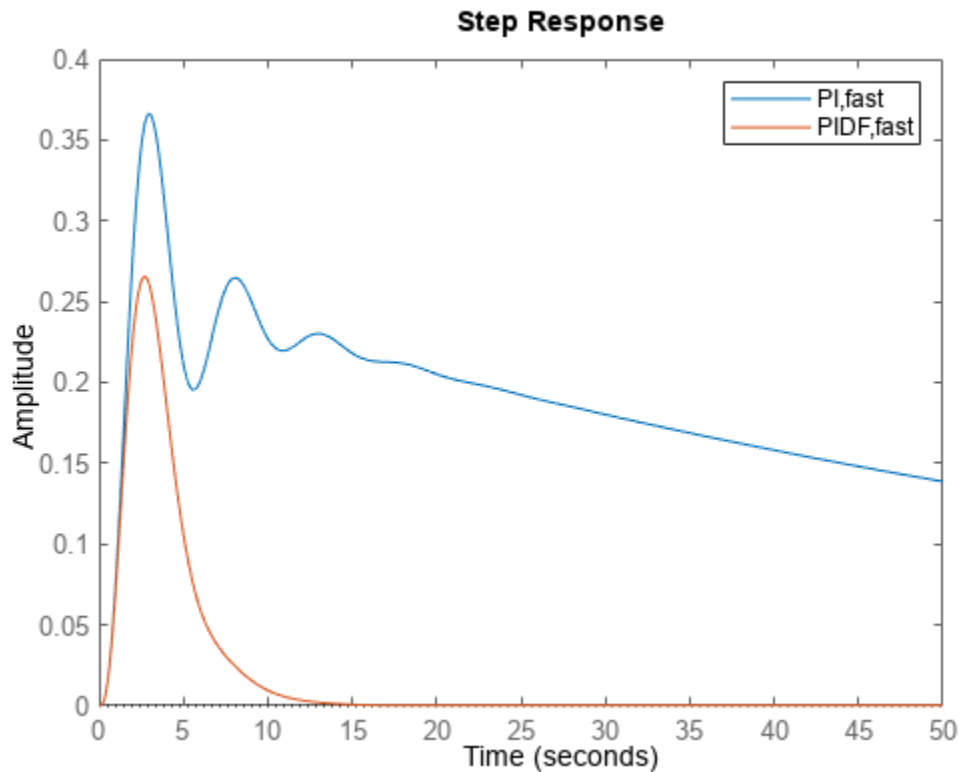

This plot shows that the PIDF controller also provides faster disturbance rejection.

Design Standard-Form PID Controller

Design a PID controller in standard form for the following plant.

$$\text{sys} = \frac{1}{(s + 1)^3}$$

To design a controller in standard form, use a standard-form controller as the `C0` argument to `pidtune`.

```
sys = zpk([], [-1 -1 -1], 1);
C0 = pidstd(1, 1, 1);
C = pidtune(sys, C0)
```

C =

$$K_p * \left(1 + \frac{1}{T_i} * \frac{1}{s} + T_d * s \right)$$

with $K_p = 2.18$, $T_i = 2.57$, $T_d = 0.642$

Continuous-time PID controller in standard form

Specify Integrator Discretization Method

Design a discrete-time PI controller using a specified method to discretize the integrator.

If your plant is in discrete time, `pidtune` automatically returns a discrete-time controller using the default Forward Euler integration method. To specify a different integration method, use `pid` or `pidstd` to create a discrete-time controller having the desired integration method.

```
sys = c2d(tf([1 1],[1 5 6]),0.1);
C0 = pid(1,1,'Ts',0.1,'IFormula','BackwardEuler');
C = pidtune(sys,C0)
```

C =

$$K_p + K_i * \frac{T_s * z}{z-1}$$

with $K_p = -0.0658$, $K_i = 1.32$, $T_s = 0.1$

Sample time: 0.1 seconds

Discrete-time PI controller in parallel form.

Using `C0` as an input causes `pidtune` to design a controller `C` of the same form, type, and discretization method as `C0`. The display shows that the integral term of `C` uses the Backward Euler integration method.

Specify a Trapezoidal integrator and compare the resulting controller.

```
C0_tr = pid(1,1,'Ts',0.1,'IFormula','Trapezoidal');
Ctr = pidtune(sys,C0_tr)
```

Ctr =

$$K_i * \frac{T_s * (z+1)}{2 * (z-1)}$$

with $K_i = 1.32$, $T_s = 0.1$

Sample time: 0.1 seconds

Discrete-time I-only controller.

Design 2-DOF PID Controller

Design a 2-DOF PID Controller for the plant given by the transfer function:

$$G(s) = \frac{1}{s^2 + 0.5s + 0.1}$$

Use a target bandwidth of 1.5 rad/s.

```

wc = 1.5;
G = tf(1,[1 0.5 0.1]);
C2 = pidtune(G, 'PID2',wc)

```

C2 =

$$u = K_p (b \cdot r - y) + K_i \frac{1}{s} (r - y) + K_d \cdot s (c \cdot r - y)$$

with $K_p = 1.26$, $K_i = 0.255$, $K_d = 1.38$, $b = 0.665$, $c = 0$

Continuous-time 2-DOF PID controller in parallel form.

Using the type 'PID2' causes `pidtune` to generate a 2-DOF controller, represented as a `pid2` object. The display confirms this result. The display also shows that `pidtune` tunes all controller coefficients, including the setpoint weights b and c , to balance performance and robustness.

Tips

- By default, `pidtune` with the `type` input returns a `pid` controller in parallel form. To design a controller in standard form, use a `pidstd` controller as input argument `C0`. For more information about parallel and standard controller forms, see the `pid` and `pidstd` reference pages.
- For interactive PID tuning in the Live Editor, see the **Tune PID Controller** Live Editor task. This task lets you interactively design a PID controller and automatically generates MATLAB code for your live script.

Algorithms

For information about the MathWorks® PID tuning algorithm, see “PID Tuning Algorithm”.

Alternatives

- For interactive PID tuning in the Live Editor, see the **Tune PID Controller** Live Editor task. This task lets you interactively design a PID controller and automatically generates MATLAB code for your live script. For an example, see “PID Controller Design in the Live Editor”
- For interactive PID tuning in a standalone app, use **PID Tuner**. See “PID Controller Design for Fast Reference Tracking” for an example of designing a controller using the app.

Version History

Introduced in R2010b

References

Åström, K. J. and Hägglund, T. *Advanced PID Control*, Research Triangle Park, NC: Instrumentation, Systems, and Automation Society, 2006.

See Also

Functions

pidtuneOptions | pidTuner

Apps

PID Tuner

Live Editor Tasks

Tune PID Controller

Objects

pid | pidstd | pid2 | pidstd2

Topics

“Tune 2-DOF PID Controller (Command Line)”

“Tune PID Controller to Favor Reference Tracking or Disturbance Rejection (Command Line)”

“Designing Cascade Control System with PI Controllers”

“PID Controller Types for Tuning”

“PID Tuning Algorithm”

pidtuneOptions

Define options for pidtune command

Syntax

```
opt = pidtuneOptions  
opt = pidtuneOptions(Name,Value)
```

Description

`opt = pidtuneOptions` returns the default option set for the `pidtune` command.

`opt = pidtuneOptions(Name,Value)` creates an option set with the options specified by one or more `Name,Value` pair arguments.

Input Arguments

Name-Value Pair Arguments

Specify optional pairs of arguments as `Name1=Value1, ..., NameN=ValueN`, where `Name` is the argument name and `Value` is the corresponding value. Name-value arguments must appear after other arguments, but the order of the pairs does not matter.

Before R2021a, use commas to separate each name and value, and enclose Name in quotes.

PhaseMargin

Target phase margin in degrees. `pidtune` attempts to design a controller such that the phase margin is at least the value specified for `PhaseMargin`. The selected crossover frequency could restrict the achievable phase margin. Typically, higher phase margin improves stability and overshoot, but limits bandwidth and response speed.

Default: 60

DesignFocus

Closed-loop performance objective to favor in the design. For a given target phase margin, `pidtune` chooses a controller design that balances the two measures of performance, reference tracking and disturbance rejection. When you change the `DesignFocus` option, the tuning algorithm attempts to adjust the PID gains to favor either reference tracking or disturbance rejection while achieving the same target phase margin. In the control architecture assumed by `pidtune`, shown in the following diagram, reference tracking is the response at y to signals at r , and disturbance rejection is the suppression at y of signals at d .

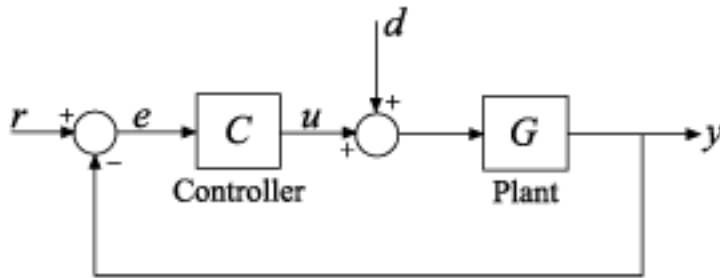

The DesignFocus option can take the following values:

- 'balanced' (default) — For a given robustness, tune the controller to balance reference tracking and disturbance rejection.
- 'reference-tracking' — Tune the controller to favor reference tracking, if possible.
- 'disturbance-rejection' — Tune the controller to favor disturbance rejection, if possible.

The more tunable parameters there are in the system, the more likely it is that the PID algorithm can achieve the desired design focus without sacrificing robustness. For example, setting the design focus is more likely to be effective for PID controllers than for P or PI controllers. In all cases, how much you can fine-tune the performance of the system depends strongly on the properties of your plant.

For an example illustrating the effect of this option, see “Tune PID Controller to Favor Reference Tracking or Disturbance Rejection (Command Line)”.

Default: 'balanced'

NumUnstablePoles

Number of unstable poles in the plant. When your plant is a `frd` model or a state-space model with internal delays, you must specify the number of open-loop unstable poles (if any). Incorrect values might result in PID controllers that fail to stabilize the real plant. (`pidtune` ignores this option for other model types.)

Unstable poles are poles located at:

- $\text{Re}(s) > 0$, for continuous-time plants
- $|z| > 1$, for discrete-time plants

A pure integrator in the plant ($s = 0$) or ($|z| > 1$) does not count as an unstable pole for `NumUnstablePoles`. If your plant is a `frd` model of a plant with a pure integrator, for best results, ensure that your frequency response data covers a low enough frequency to capture the integrator slope.

Default: 0

Output Arguments

opt

Object containing the specified options for `pidtune`.

Examples

Tune a PIDF controller with a target phase margin of 45 degrees, favoring the disturbance-rejection measure of performance.

```
sys = tf(1,[1 3 3 1]);  
opts = pidtuneOptions('PhaseMargin',45,'DesignFocus','disturbance-rejection');  
[C,info] = pidtune(sys,'pid',opts);
```

Tips

- When using the `pidtune` command to design a PID controller for a plant with unstable poles, if your plant model is one of the following:
 - A `frd` model
 - A `ss` model with internal delays that cannot be converted to I/O delays

then use `pidtuneOptions` to specify the number of unstable poles in the plant.

Version History

Introduced in R2010b

See Also

`pidtune`

Topics

“PID Tuning Algorithm”

“Tune PID Controller to Favor Reference Tracking or Disturbance Rejection (Command Line)”

PID Tuner

Tune PID controllers

Description

The **PID Tuner** app automatically tunes the gains of a PID controller for a SISO plant to achieve a balance between performance and robustness. You can specify the controller type, such as PI, PID with derivative filter, or two-degree-of-freedom (2-DOF) PID controllers. Analysis plots let you examine controller performance in time and frequency domains. You can interactively refine the performance of the controller to adjust loop bandwidth and phase margin, or to favor setpoint tracking or disturbance rejection.

You can use **PID Tuner** with a plant represented by a numeric LTI model such as a transfer function (`tf`) or state-space (`ss`) model. If you have Simulink Control Design software, you can use **PID Tuner** to tune a PID Controller or PID Controller (2DOF) block in a Simulink model. If you have System Identification Toolbox software, you can use the app to estimate a plant from measured or simulated data and design a controller for the estimated plant.

Interactive Tuning in the Live Editor

For interactive PID tuning in the Live Editor, see the **Tune PID Controller** Live Editor task. This task lets you interactively design a PID controller and automatically generates MATLAB code for your live script.

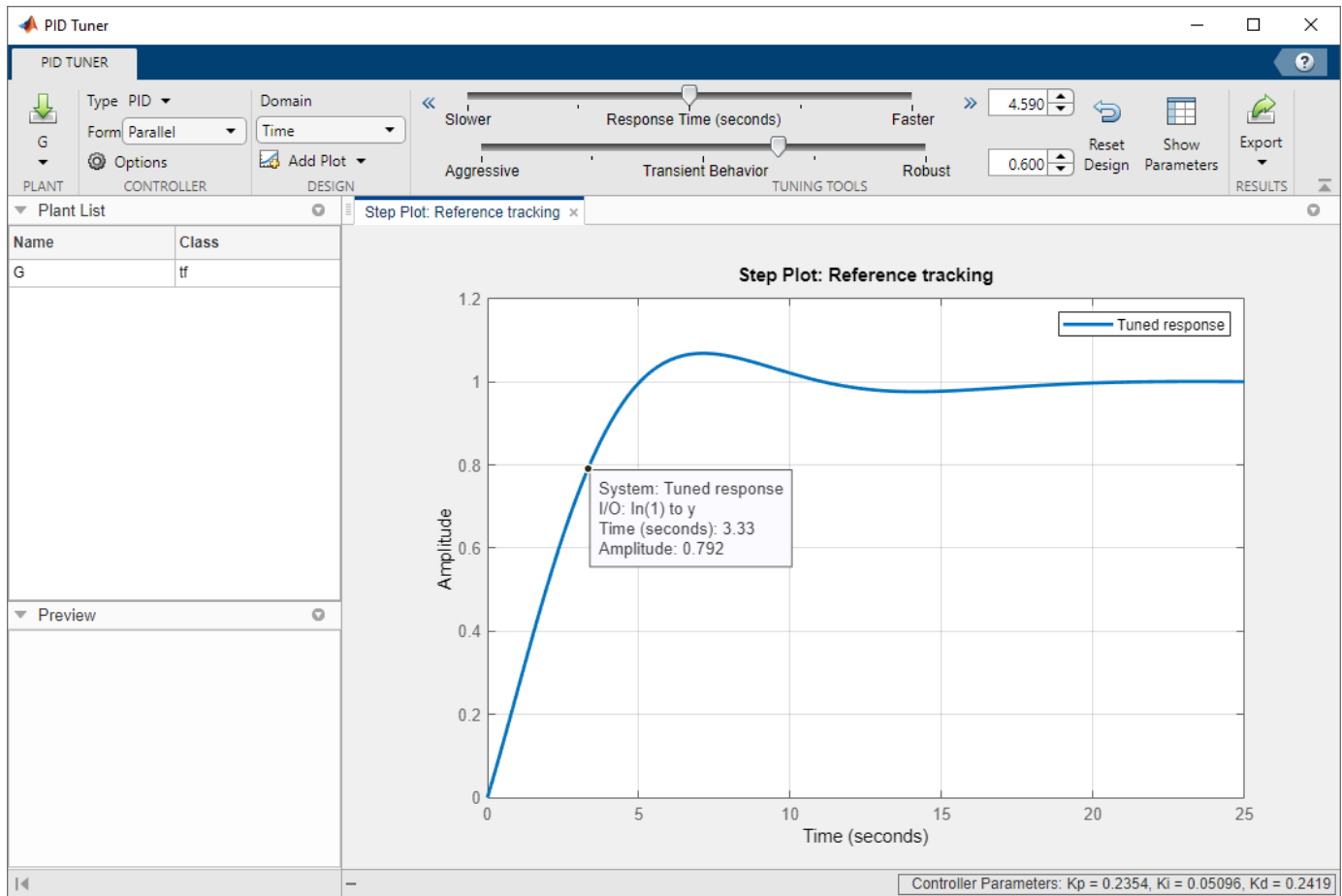

Open the PID Tuner App

- MATLAB Toolstrip: On the **Apps** tab, under **Control System Design and Analysis**, click the app icon.
- MATLAB command prompt: Enter `pidTuner`.
- Simulink model: In the PID Controller or PID Controller (2DOF) block dialog box, click **Tune**.

Examples

- “Tune PID Controller to Favor Reference Tracking or Disturbance Rejection (PID Tuner)”
- “PID Controller Tuning in Simulink” (Simulink Control Design)
- “Designing PID Controllers with PID Tuner”
- “Introduction to Model-Based PID Tuning in Simulink” (Simulink Control Design)

Parameters

Plant — Current plant

LTI model in Data Browser | Import | ...

The **Plant** menu displays the name of the current plant that **PID Tuner** is using for controller design.

Change the current plant using the following menu options:

- A list of the LTI models present in the **PID Tuner** Data Browser.
- **Import** — Import a new LTI model from the MATLAB workspace.
- **Re-Linearize Closed Loop** — Linearize the plant at a different snapshot time. See “Tune at a Different Operating Point” (Simulink Control Design). This option is available only when tuning a PID Controller or PID Controller (2DOF) block in a Simulink model.
- **Identify New Plant** — Use system identification to obtain a plant from measured or simulated system response data (requires System Identification Toolbox software). See:
 - “Interactively Estimate Plant Parameters from Response Data”, when tuning a PID controller for an LTI model.
 - “Interactively Estimate Plant from Measured or Simulated Response Data” (Simulink Control Design), when tuning a PID Controller block in a Simulink model.

If you are tuning a PID controller for a plant represented by an LTI model, the default plant is:

- **Plant = 1**, if you opened **PID Tuner** from the **Apps** tab in the MATLAB Toolstrip, or if you used the `pidTuner` command without an input argument.
- The plant you specified as an input argument to `pidTuner`.

If you are tuning a PID Controller or PID Controller (2DOF) block in a Simulink model, then the default plant is linearized at the operating point specified by the model initial conditions. See “What Plant Does PID Tuner See?” (Simulink Control Design)

Type — Controller type

'PI' | 'PIDF' | 'PID2' | ...

The controller type specifies which terms are present in the PID controller. For instance, a PI controller has a proportional and an integral term. A PDF controller has a proportional term and a filtered derivative term.

- If you are tuning a controller for a plant represented by an LTI model, use the **Type** menu to specify controller type. When you change controller type, **PID Tuner** automatically designs a new controller. Available controller types include 2-DOF PID controllers for more flexibility in the trade-off between disturbance rejection and reference tracking. For details on available controller types, see “PID Controller Types for Tuning”.
- If you are tuning a PID Controller or PID Controller (2DOF) block in a Simulink model, the **Type** field displays the controller type specified in the block dialog box.

Form — Controller form

'Parallel' | 'Standard'

This field displays the controller form.

- If you are tuning a controller for a plant represented by an LTI model, use the **Form** menu to specify controller form. For information about parallel and standard forms, see the `pid` and `pidstd` reference pages.
- If you are tuning a PID Controller or PID Controller (2DOF) block in a Simulink model, the **Form** field displays the controller form specified in the block dialog box.

Domain — Domain for specifying performance targets

'Time' | 'Frequency'

The **Domain** menu enables you to switch the domain in which PID Tuner displays the target performance parameters.

- Time — Sliders set the **Response Time** and **Transient Behavior**.
- Frequency — Sliders set the **Bandwidth** and **Phase Margin**.

To refine the controller design, you adjust the target performance parameters using the sliders or the corresponding numeric values.

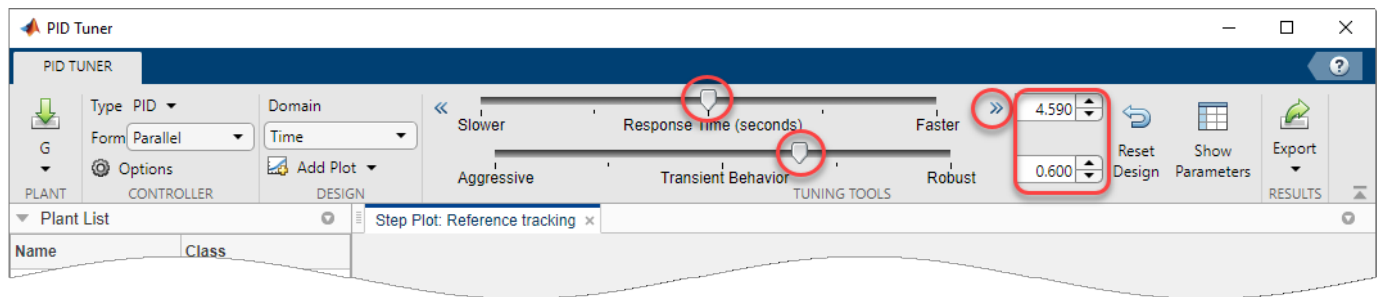

For more information, see:

- “Refine the Design” (tuning a controller for an LTI model)
- “Refine the Design” (Simulink Control Design) (tuning PID Controller or PID Controller (2DOF) block in Simulink model)

Add Plot — Create analysis plots

Reference Tracking | Input Disturbance Rejection | Controller Effort | ...

Create time-domain and frequency-domain analysis plots to help analyze the performance of the PID controller. For detailed information about the available response plots, see:

- “Analyze Design in PID Tuner” (tuning a controller for an LTI model)
- “Analyze Design in PID Tuner” (Simulink Control Design) (tuning PID Controller or PID Controller (2DOF) block in Simulink model)

Programmatic Use

pidTuner

Tips

- For PID tuning at the command line, use `pidtune`. The `pidtune` command can design a controller for multiple plants at once.
- For interactive PID tuning in the Live Editor, see the **Tune PID Controller** Live Editor task. This task lets you interactively design a PID controller and automatically generates MATLAB code for your live script.

Version History

Introduced in R2010b

See Also

Functions

pidtune

Live Editor Tasks

Tune PID Controller

Topics

“Tune PID Controller to Favor Reference Tracking or Disturbance Rejection (PID Tuner)”

“PID Controller Tuning in Simulink” (Simulink Control Design)

“Designing PID Controllers with PID Tuner”

“Introduction to Model-Based PID Tuning in Simulink” (Simulink Control Design)

pidTuner

Open PID Tuner for PID tuning

Syntax

```
pidTuner(sys,type)
pidTuner(sys,Cbase)
pidTuner(sys)
pidTuner
```

Description

`pidTuner(sys,type)` launches the **PID Tuner** app and designs a controller of type `type` for plant `sys`.

`pidTuner(sys,Cbase)` launches PID Tuner with a baseline controller `Cbase` so that you can compare performance between the designed controller and the baseline controller. If `Cbase` is a `pid`, `pidstd`, `pid2` or `pidstd2` controller object, PID Tuner designs a controller of the same form, `type`, and discrete integrator formulas as `Cbase`.

`pidTuner(sys)` designs a parallel-form PI controller.

`pidTuner` launches PID Tuner with default plant of 1 and proportional (P) controller of 1.

Input Arguments

`sys`

Plant model for controller design. `sys` can be:

- Any SISO LTI system (such as `ss`, `tf`, `zpk`, or `frd`).
- Any System Identification Toolbox SISO linear model (`idtf`, `idfrd`, `idgrey`, `idpoly`, `idproc`, or `idss`).
- A continuous- or discrete-time model.
- Stable, unstable, or integrating. However, you might not be able to stabilize a plant with unstable poles under PID control.
- A model that includes any type of time delay. A plant with long time delays, however, might not achieve adequate performance under PID control.

If the plant has unstable poles, and `sys` is either:

- A `frd` model
- A `ss` model with internal time delays that cannot be converted to I/O delays

then you must specify the number of unstable poles in the plant. To do this, after opening PID Tuner,

in the **Plant** menu, select  **Import**. In the Import Linear System dialog box, reimport `sys`, specifying the number of unstable poles where prompted.

type

Controller type of the controller to design, specified as a character vector. The term controller type refers to which terms are present in the controller action. For example, a PI controller has only a proportional and an integral term, while a PIDF controller contains proportional, integrator, and filtered derivative terms. `type` can take the values summarized below. For more detailed information about these controller types, see “PID Controller Types for Tuning”

1-DOF Controllers

- 'P' — Proportional only
- 'I' — Integral only
- 'PI' — Proportional and integral
- 'PD' — Proportional and derivative
- 'PDF' — Proportional and derivative with first-order filter on derivative term
- 'PID' — Proportional, integral, and derivative
- 'PIDF' — Proportional, integral, and derivative with first-order filter on derivative term

2-DOF Controllers

- 'PI2' — 2-DOF proportional and integral
- 'PD2' — 2-DOF proportional and derivative
- 'PDF2' — 2-DOF proportional and derivative with first-order filter on derivative term
- 'PID2' — 2-DOF proportional, integral, and derivative
- 'PIDF2' — 2-DOF proportional, integral, and derivative with first-order filter on derivative term

For more information about 2-DOF PID controllers generally, see “Two-Degree-of-Freedom PID Controllers”.

2-DOF Controllers with Fixed Setpoint Weights

- 'I-PD' — 2-DOF PID with $b = 0$, $c = 0$
- 'I-PDF' — 2-DOF PIDF with $b = 0$, $c = 0$
- 'ID-P' — 2-DOF PID with $b = 0$, $c = 1$
- 'IDF-P' — 2-DOF PIDF with $b = 0$, $c = 1$
- 'PI-D' — 2-DOF PID with $b = 1$, $c = 0$
- 'PI-DF' — 2-DOF PIDF with $b = 1$, $c = 0$

For more detailed information about fixed-setpoint-weight 2-DOF PID controllers, see “PID Controller Types for Tuning”.

Controller Form

When you use the `type` input, PID Tuner designs a controller in parallel form. If you want to design a controller in standard form, Use the input `Cbase` instead of `type`, or select `Standard` from the **Form** menu. For more information about parallel and standard forms, see the `pid` and `pidstd` reference pages.

If `sys` is a discrete-time model with sample time `Ts`, PID Tuner designs a discrete-time `pid` controller using the `ForwardEuler` discrete integrator formula. To design a controller having a different discrete integrator formula:

- Use the input argument `Cbase` instead of `type`. PID Tuner reads controller type, form, and discrete integrator formulas from the baseline controller `Cbase`.
- In PID Tuner, click **Options** to open the Controller Options dialog box. Select discrete integrator formulas from the **Integral Formula** and **Derivative Formula** menus.

For more information about discrete integrator formulas, see the `pid` and `pidstd` reference pages.

Cbase

A dynamic system representing a baseline controller, permitting comparison of the performance of the designed controller to the performance of `Cbase`.

If `Cbase` is a `pid` or `pidstd` object, PID Tuner also uses it to configure the type, form, and discrete integrator formulas of the designed controller. The designed controller:

- Is the type represented by `Cbase`.
- Is a parallel-form controller, if `Cbase` is a `pid` controller object.
- Is a standard-form controller, if `Cbase` is a `pidstd` controller object.
- Is a parallel-form 2-DOF controller, if `Cbase` is a `pid2` controller object.
- Is a standard-form 2-DOF controller, if `Cbase` is a `pidstd2` controller object.
- Has the same `Iformula` and `Dformula` values as `Cbase`. For more information about `Iformula` and `Dformula`, see the `pid` and `pidstd` reference pages .

If `Cbase` is any other dynamic system, PID Tuner designs a parallel-form PI controller. You can change the controller form and type using the **Form** and **Type** menus after launching PID Tuner.

Examples

Interactive PID Tuning of Parallel-Form Controller

Launch PID Tuner to design a parallel-form PIDF controller for a discrete-time plant:

```
Gc = zpk([], [-1 -1 -1], 1);
Gd = c2d(Gc, 0.1);           % Create discrete-time plant

pidTuner(Gd, 'pidf')        % Launch PID Tuner
```

Interactive PID Tuning of Standard-Form Controller Using Integrator Discretization Method

Design a standard-form PIDF controller using BackwardEuler discrete integrator formula:

```
Gc = zpk([], [-1 -1 -1], 1);
Gd = c2d(Gc, 0.1);           % Create discrete-time plant

% Create baseline controller.
Cbase = pidstd(1,2,3,4, 'Ts', 0.1, ...
    'IFormula', 'BackwardEuler', 'DFormula', 'BackwardEuler')

pidTuner(Gd, Cbase)         % Launch PID Tuner
```

PID Tuner designs a controller for `Gd` having the same form, type, and discrete integrator formulas as `Cbase`. For comparison, you can display the response plots of `Cbase` with the response plots of the designed controller by clicking the **Show baseline** checkbox in PID Tuner.

Tips

- If `type` or `Cbase` specifies a one-degree-of-freedom (1-DOF) PID controller, then `pidTuner` designs a controller for the unit feedback loop as illustrated:

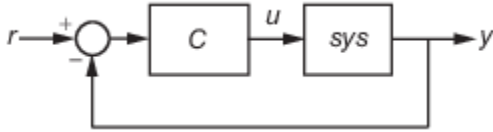

- If `type` or `Cbase` specifies a two-degree-of-freedom (2-DOF) PID controller, then `pidTuner` designs a 2-DOF controller as in the feedback loop of this illustration:

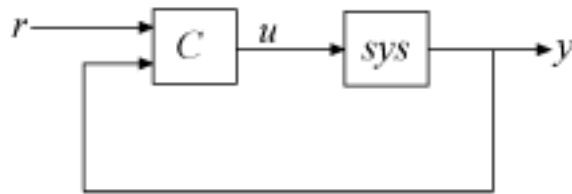

- PID Tuner has a default target phase margin of 60 degrees and automatically tunes the PID gains to balance performance (response time) and robustness (stability margins). Use the **Response time** or **Bandwidth** and **Phase Margin** sliders to tune the controller's performance to your requirements. Increasing performance typically decreases robustness, and vice versa.
- Select response plots from the **Response** menu to analyze the controller's performance.
- If you provide `Cbase`, check **Show baseline** to display the response of the baseline controller.
- For more detailed information about using PID Tuner, see "Designing PID Controllers with PID Tuner".
- For interactive PID tuning in the Live Editor, see the **Tune PID Controller** Live Editor task. This task lets you interactively design a PID controller and automatically generates MATLAB code for your live script.

Algorithms

For information about the MathWorks PID tuning algorithm, see "PID Tuning Algorithm".

Alternatives

You can open PID Tuner from the MATLAB desktop, in the **Apps** tab. When you do so, use the **Plant** menu in PID Tuner to specify your plant model.

For PID tuning at the command line, use `pidtune`. The `pidtune` command can design a controller for multiple plants at once.

For interactive PID tuning in the Live Editor, see the **Tune PID Controller** Live Editor task. This task lets you interactively design a PID controller and automatically generates MATLAB code for your live script.

Version History

Introduced in R2014b

References

Åström, K. J. and Hägglund, T. *Advanced PID Control*, Research Triangle Park, NC: Instrumentation, Systems, and Automation Society, 2006.

See Also

Functions

pidtune

Objects

pid | pidstd | pid2 | pidstd2

Live Editor Tasks

Tune PID Controller

Topics

“Tune PID Controller to Favor Reference Tracking or Disturbance Rejection (PID Tuner)”

“Tune 2-DOF PID Controller (PID Tuner)”

“Designing PID Controllers with PID Tuner”

“PID Controller Types for Tuning”

place

Pole placement design

Syntax

```
K = place(A,B,p)
[K,prec] = place(A,B,p)
```

Description

Pole placement is a method of calculating the optimum gain matrix used to assign closed-loop poles to specified locations, thereby ensuring system stability. Closed-loop pole locations have a direct impact on time response characteristics such as rise time, settling time, and transient oscillations. For more information, see "Pole Placement".

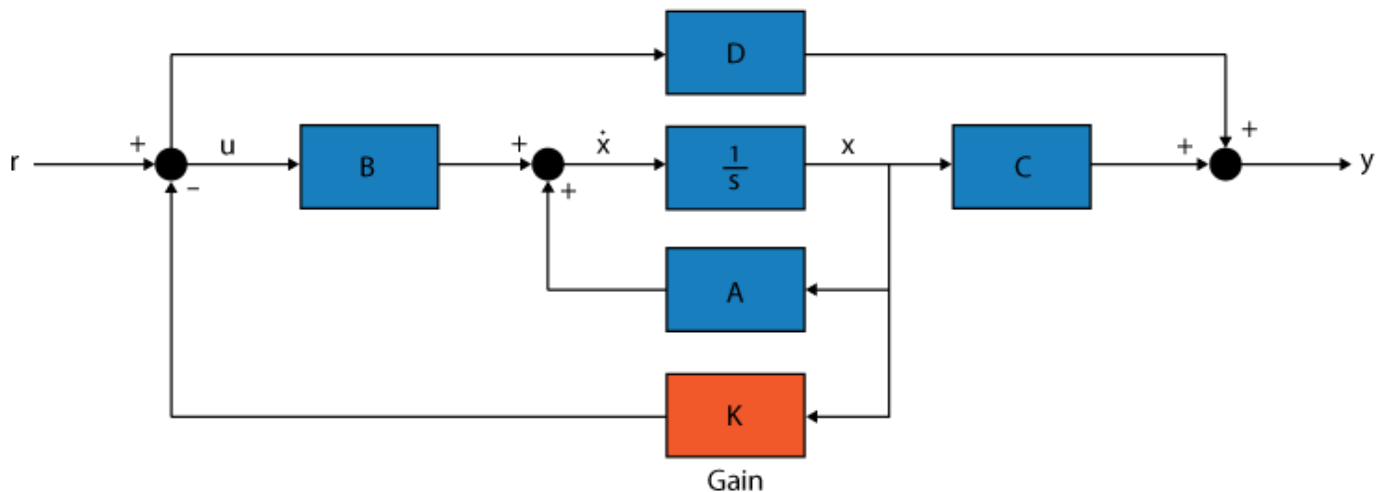

From the figure, consider a linear dynamic system in state-space form

$$\dot{x} = Ax + Bu$$

$$y = Cx + Du$$

For a given vector p of desired self-conjugate closed-loop pole locations, `place` computes a gain matrix K such that the state feedback $u = -Kx$ places the poles at the locations p . In other words, the eigenvalues of $A - BK$ will match the entries of p (up to the ordering).

`K = place(A,B,p)` places the desired closed-loop poles p by computing a state-feedback gain matrix K . All the inputs of the plant are assumed to be control inputs. `place` also works for multi-input systems and is based on the algorithm from [1]. This algorithm uses the extra degrees of freedom to find a solution that minimizes the sensitivity of the closed-loop poles to perturbations in A or B .

`[K,prec] = place(A,B,p)` also returns `prec`, an accuracy estimate of how closely the eigenvalues of $A - BK$ match the specified locations p (`prec` measures the number of accurate

decimal digits in the actual closed-loop poles). A warning is issued if some nonzero closed-loop pole is more than 10% off from the desired location.

Examples

Pole Placement Design for Second-Order System

For this example, consider a simple second-order system with the following state-space matrices:

$$A = \begin{bmatrix} -1 & -2 \\ 1 & 0 \end{bmatrix} \quad B = \begin{bmatrix} 2 \\ 0 \end{bmatrix} \quad C = [0 \ 1] \quad D = 0$$

Input the matrices and create the state-space system.

```
A = [-1, -2; 1, 0];  
B = [2; 0];  
C = [0, 1];  
D = 0;  
sys = ss(A, B, C, D);
```

Compute the open-loop poles and check the step response of the open-loop system.

```
Pol = pole(sys)
```

```
Pol = 2×1 complex  
-0.5000 + 1.3229i  
-0.5000 - 1.3229i
```

```
figure(1)  
step(sys)  
hold on;
```

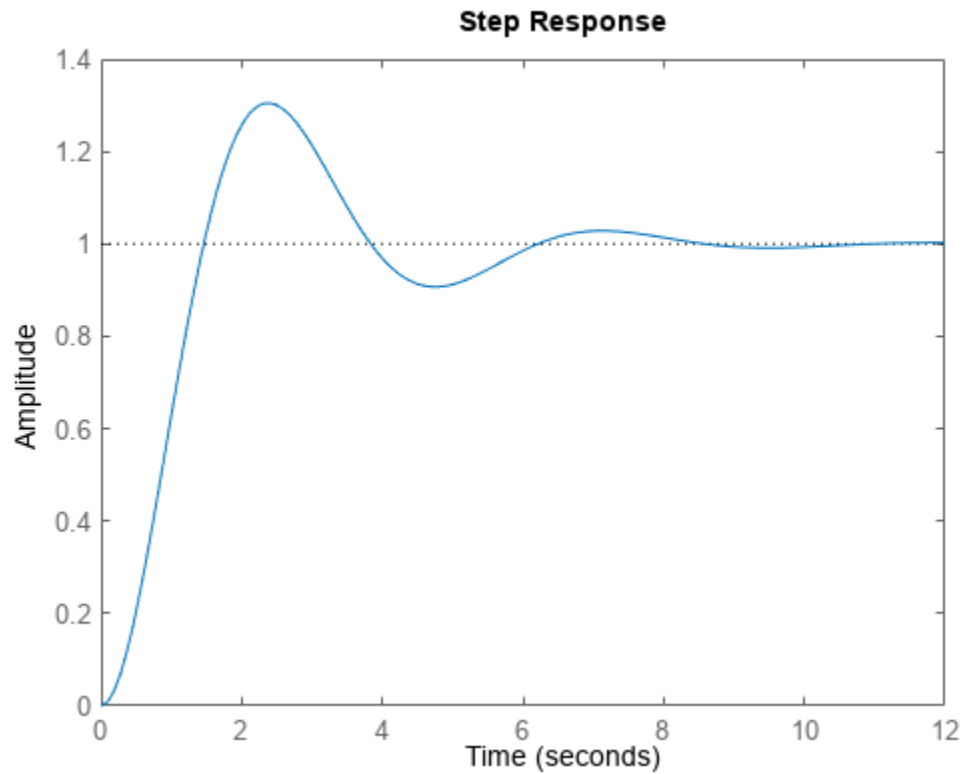

Notice that there is an unstable pole, and the resultant system is underdamped. Hence, choose real poles in the left half of the complex-plane to remove oscillations.

```
p = [-1, -2];
```

Find the gain matrix K using pole placement and check the closed-loop poles of syscl.

```
K = place(A,B,p);
Acl = A-B*K;
syscl = ss(Acl,B,C,D);
Pcl = pole(syscl)
```

```
Pcl = 2×1
```

```
 -2.0000
 -1.0000
```

Now, compare the step response of the closed-loop system.

```
figure(1)
step(syscl)
```

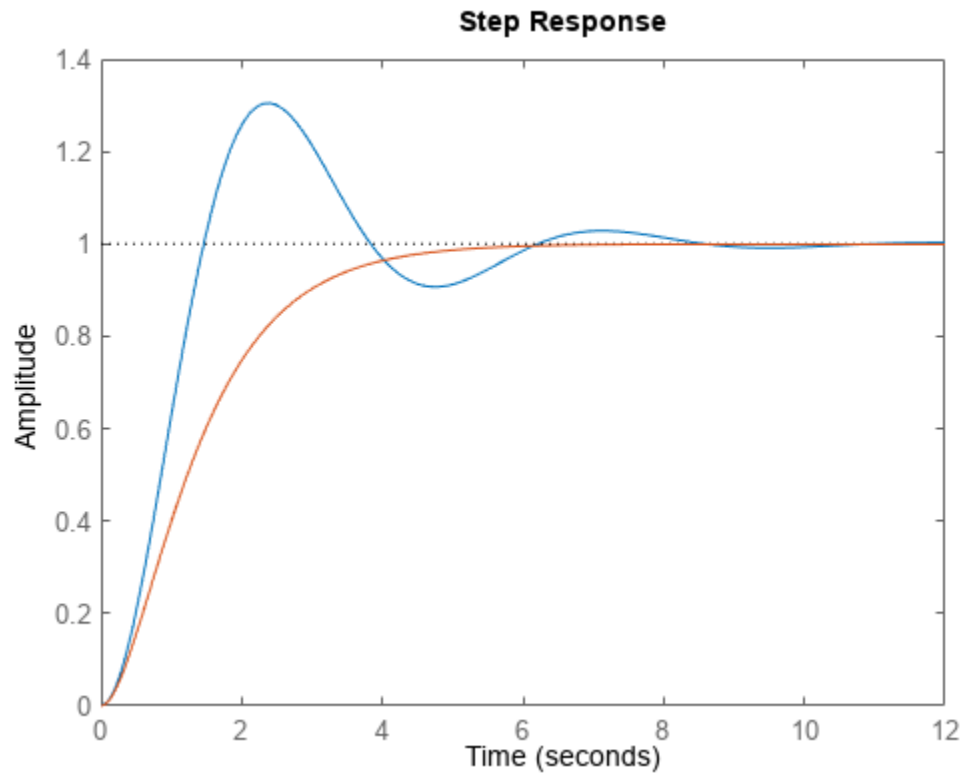

Hence, the closed-loop system obtained using pole placement is stable with good steady-state response.

Note that choosing poles that are further away from the imaginary axis achieves faster response time but lowers the steady-state gain of the system. For instance, consider using the poles $[-2, -3]$ for the above system.

```
p = [-2, -3];  
K2 = place(A,B,p);  
syscl2 = ss(A-B*K2,B,C,D);  
figure(1);  
step(syscl2);
```

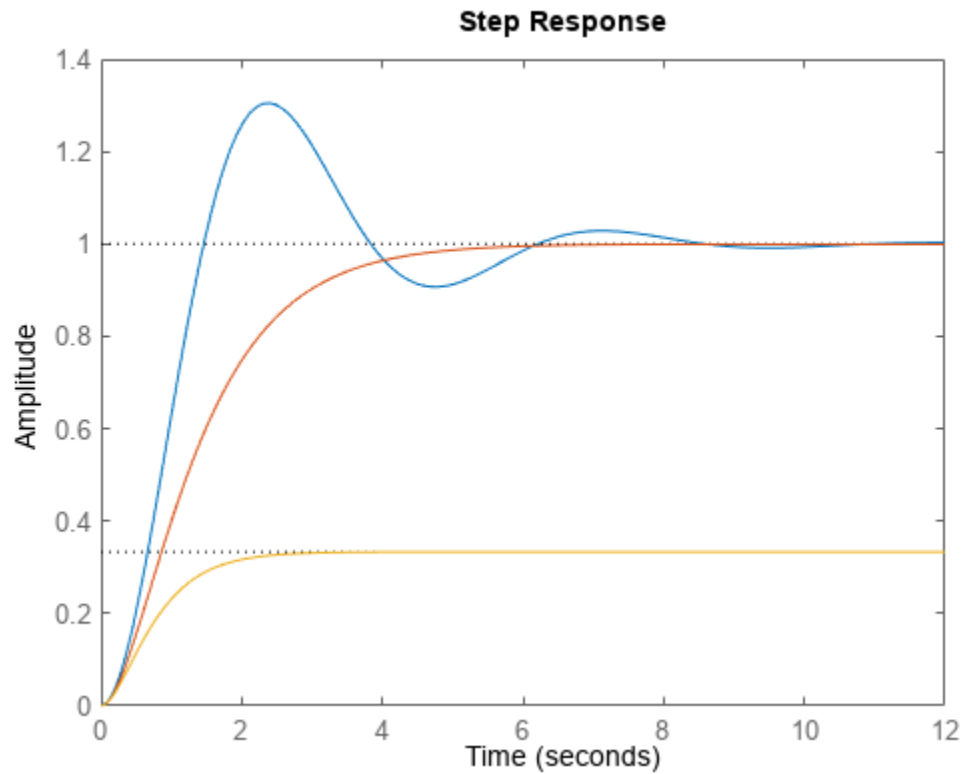

```
stepinfo(syscl)
```

```
ans = struct with fields:  
    RiseTime: 2.5901  
    TransientTime: 4.6002  
    SettlingTime: 4.6002  
    SettlingMin: 0.9023  
    SettlingMax: 0.9992  
    Overshoot: 0  
    Undershoot: 0  
    Peak: 0.9992  
    PeakTime: 7.7827
```

```
stepinfo(syscl2)
```

```
ans = struct with fields:  
    RiseTime: 1.4130  
    TransientTime: 2.4766  
    SettlingTime: 2.4766  
    SettlingMin: 0.3003  
    SettlingMax: 0.3331  
    Overshoot: 0  
    Undershoot: 0  
    Peak: 0.3331  
    PeakTime: 4.1216
```

Pole Placement Precision

For this example, consider the pole locations $[-2e-13, -3e-4, -3e-3]$. Compute the precision of the actual poles.

```
A = [4,2,1;0,-1,2;0,1e-8,1];
B = [1,2;3,1;1e-6,0];
p = [-2e-13,-3e-4,3e-3];
[~,prec] = place(A,B,p)
```

```
prec = 2
```

A precision value of 2 is obtained indicating that the actual pole locations are precise up to 2 decimal places.

Pole Placement using Complex Poles

For this example, consider the following transfer function with complex-conjugate poles at $-2 \pm 2i$:

$$\text{systf}(s) = \frac{8}{s^2 + 4s + 8}$$

Input the transfer function model. Then, convert it to state-space form since `place` uses the A and B matrices as input arguments.

```
s = tf('s');
systf = 8/(s^2+4*s+2);
sys = ss(systf);
```

Next, compute the gain matrix K using the complex-conjugate poles.

```
p = [-2+2i,-2-2i];
K = place(sys.A,sys.B,p)
```

```
K = 1x2
```

```
0    1.5000
```

The values of the gain matrix are real since the poles are self-conjugate. The values of K would be complex if p did not contain self-conjugate poles.

Now, verify the step response of the closed-loop system.

```
syscl = ss(sys.A-sys.B*K,sys.B,sys.C,sys.D);
step(syscl)
```

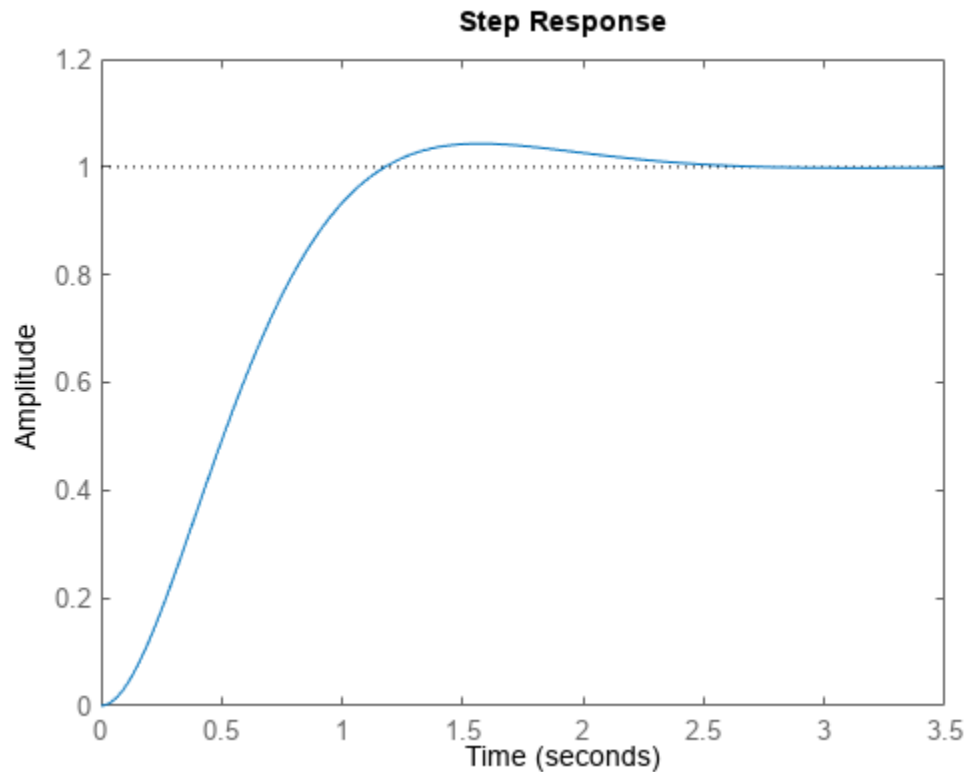
Pole Placement Observer Design

For this example, consider the following SISO state-space model:

$$A = \begin{bmatrix} -1 & -0.75 \\ 1 & 0 \end{bmatrix} \quad B = \begin{bmatrix} 1 \\ 0 \end{bmatrix} \quad C = [1 \ 1] \quad D = 0$$

Create the SISO state-space model defined by the following state-space matrices:

```
A = [-1, -0.75; 1, 0];
B = [1; 0];
C = [1, 1];
D = 0;
Plant = ss(A,B,C,D);
```

Now, provide a pulse to the plant and simulate it using `lsim`. Plot the output.

```
N = 250;
t = linspace(0, 25, N);
u = [ones(N/2, 1); zeros(N/2, 1)];
x0 = [1; 2];
[y, t, x] = lsim(Plant, u, t, x0);
```

figure

```
plot(t,y);
title('Output');
```

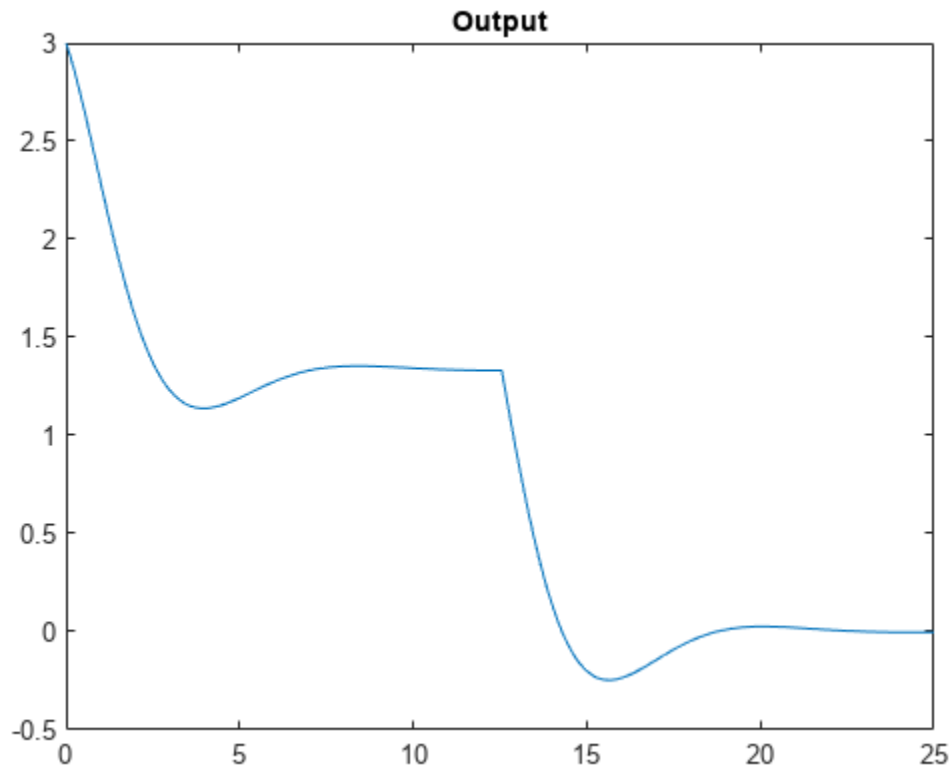

For this example, assume that all the state variables cannot be measured and only the output is measured. Hence, design an observer with this measurement. Use `place` to compute the estimator gain by transposing the A matrix and substituting C' for matrix B. For this instance, select the desired pole locations at -2 and -3.

```
L = place(A',C',[-2,-3])';
```

Use the estimator gain to substitute the state matrices using the principle of duality/separation and create the estimated state-space model.

```
At = A-L*C;
Bt = [B,L];
Ct = [C;eye(2)];
sysObserver = ss(At,Bt,Ct,0);
```

Simulate the time response of the system using the same pulse input.

```
[observerOutput,t] = lsim(sysObserver,[u,y],t);
yHat = observerOutput(:,1);
xHat = observerOutput(:,[2 3]);
```

Compare the response of the actual system and the estimated system.

```
figure;
plot(t,x);
```

```

hold on;
plot(t,xHat,'--');
legend('x_1','x_2','xHat_1','xHat_2')
title('Comparison - Actual vs. Estimated');

```

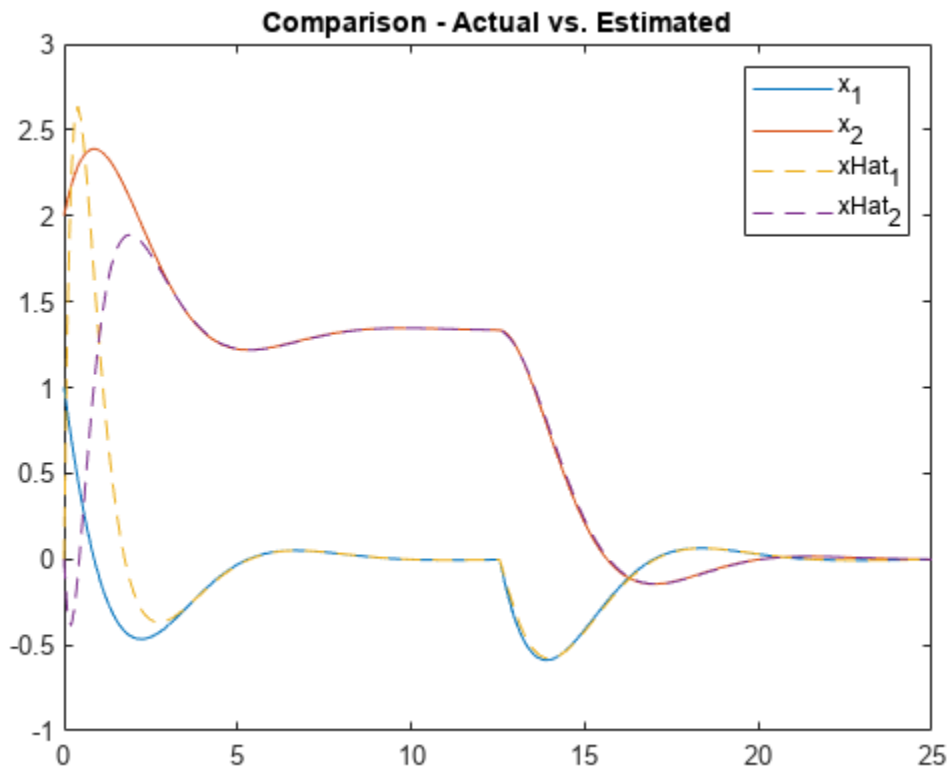

Input Arguments

A — State matrix

N_x -by- N_x matrix

State matrix, specified as an N_x -by- N_x matrix where, N_x is the number of states.

B — Input-to-state matrix

N_x -by- N_u matrix

Input-to-state matrix, specified as an N_x -by- N_u matrix where, N_x is the number of states and N_u is the number of inputs.

p — Closed-loop pole locations

vector

Closed-loop pole locations, specified as a vector of length N_x where, N_x is the number of states. In other words, the length of p must match the row size of A . Closed-loop pole locations have a direct impact on time response characteristics such as rise time, settling time, and transient oscillations.

For an example on selecting poles, see “Pole Placement Design for Second-Order System” on page 2-1010.

`place` returns an error if some poles in `p` have multiplicity greater than `rank(B)`.

In high-order problems, some choices of pole locations result in very large gains. The sensitivity problems attached with large gains suggest caution in the use of pole placement techniques. See [2] for results from numerical testing.

Output Arguments

K — Optimum gain

N_y-by-N_x matrix

Optimum gain or full-state feedback gain, returned as an *N_y-by-N_x* matrix where, *N_x* is the number of states and *N_y* is the number of outputs. `place` computes a gain matrix *K* such that the state feedback $u = -Kx$ places the closed-loop poles at the locations `p`.

When the matrices *A* and *B* are real, *K* is

- real when `p` is self-conjugate.
- complex when the pole locations are not complex-conjugates.

prec — Accuracy estimate of the assigned poles

scalar

Accuracy estimate of the assigned poles, returned as a scalar. `prec` measures the number of accurate decimal digits in the actual closed-loop poles in contrast to the pole locations specified in `p`.

Tips

- You can use `place` for estimator gain selection by transposing the *A* matrix and substituting *C*' for matrix *B* as follows, as shown in “Pole Placement Observer Design” on page 2-1015. You can use the resultant estimator gain for state estimator workflows using `estim`.

Version History

Introduced before R2006a

References

- [1] Kautsky, J., N.K. Nichols, and P. Van Dooren, “Robust Pole Assignment in Linear State Feedback,” *International Journal of Control*, 41 (1985), pp. 1129-1155.
- [2] Laub, A.J. and M. Wette, *Algorithms and Software for Pole Assignment and Observers*, UCRL-15646 Rev. 1, EE Dept., Univ. of Calif., Santa Barbara, CA, Sept. 1984.

See Also

`lqr` | `rlocus` | `estim`

Topics

“Pole Placement”

External Websites

MATLAB Tech Talks - Pole Placement

pole

Poles of dynamic system

Syntax

```
P = pole(sys)
P = pole(sys,J1,...,JN)
```

Description

`P = pole(sys)` returns the poles of the SISO or MIMO dynamic system model `sys`. The output is expressed as the reciprocal of the time units specified in `sys.TimeUnit`. The poles of a dynamic system determine the stability and response of the system.

An open-loop linear time-invariant system is stable if:

- In continuous-time, all the poles of the transfer function have negative real parts. When the poles are visualized on the complex s -plane, then they must all lie in the left-half plane (LHP) to ensure stability.
- In discrete-time, all the poles must have a magnitude strictly smaller than one, that is they must all lie inside the unit circle.

`P = pole(sys,J1,...,JN)` returns the poles `P` of the entries in model array `sys` with subscripts `(J1,...,JN)`.

Examples

Poles of Discrete-Time Transfer Function

Compute the poles of the following discrete-time transfer function:

$$\text{sys}(z) = \frac{0.0478z - 0.0464}{z^2 - 1.81z + 0.9048}$$

```
sys = tf([0.04798 0.0464],[1 -1.81 0.9048],0.1);
P = pole(sys)
```

```
P = 2×1 complex
```

```
0.9050 + 0.2929i
0.9050 - 0.2929i
```

For stable discrete systems, all their poles must have a magnitude strictly smaller than one, that is they must all lie inside the unit circle. The poles in this example are a pair of complex conjugates, and lie inside the unit circle. Hence, the system `sys` is stable.

Poles of Transfer Function

Calculate the poles of following transfer function:

$$\text{sys}(s) = \frac{4.2s^2 + 0.25s - 0.004}{s^2 + 9.6s + 17}$$

```
sys = tf([4.2,0.25,-0.004],[1,9.6,17]);
P = pole(sys)
```

```
P = 2×1

    -7.2576
    -2.3424
```

For stable continuous systems, all their poles must have negative real parts. `sys` is stable since the poles are negative, that is, they lie in the left half of the complex plane.

Poles of Models in an Array

For this example, load `invertedPendulumArray.mat`, which contains a 3-by-3 array of inverted pendulum models. The mass of the pendulum varies as you move from model to model along a single column of `sys`, and the length of the pendulum varies as you move along a single row. The mass values used are 100g, 200g and 300g, and the pendulum lengths used are 3m, 2m and 1m respectively.

	Column 1	Column 2	Column 3
Row 1	100g, 3m	100g, 2m	100g, 1m
Row 2	200g, 3m	200g, 2m	200g, 1m
Row 3	300g, 3m	300g, 2m	300g, 1m

```
load('invertedPendulumArray.mat','sys');
size(sys)
```

```
3×3 array of transfer functions.
Each model has 1 outputs and 1 inputs.
```

Find poles of the model array.

```
P = pole(sys);
P(:,:,2,1)
```

```
ans = 3×1

    2.1071
   -2.1642
   -0.1426
```

`P(:,:,2,1)` corresponds to the poles of the model with 200g pendulum weight and 3m length.

Input Arguments

sys — Dynamic system

dynamic system model | model array

Dynamic system, specified as a SISO or MIMO dynamic system model, or an array of SISO or MIMO dynamic system models. Dynamic systems that you can use include continuous-time or discrete-time numeric LTI models such as `tf`, `zpk`, or `ss` models.

If `sys` is a generalized state-space model `genss` or an uncertain state-space model `uss`, `pole` returns the poles of the current or nominal value of `sys`. If `sys` is an array of models, `pole` returns the poles of the model corresponding to its subscript `J1, . . . , JN` in `sys`. For more information on model arrays, see “Model Arrays”.

J1, . . . , JN — Indices of models in array whose poles you want to extract

positive integer

Indices of models in array whose poles you want to extract, specified as a positive integer. You can provide as many indices as there are array dimensions in `sys`. For example, if `sys` is a 4-by-5 array of dynamic system models, the following command extracts the poles for entry (2,3) in the array.

```
P = pole(sys,2,3);
```

Output Arguments

P — Poles of the dynamic system

column vector | array

Poles of the dynamic system, returned as a scalar or an array. If `sys` is:

- A single model, then `P` is a column vector of poles of the dynamic system model `sys`
- A model array, then `P` is an array of poles of each model in `sys`

`P` is expressed as the reciprocal of the time units specified in `sys.TimeUnit`. For example, `pole` is expressed in 1/minute if `sys.TimeUnit = 'minutes'`.

Depending on the type of system model, poles are computed in the following way:

- For state-space models, the poles are the eigenvalues of the `A` matrix, or the generalized eigenvalues of $A - \lambda E$ in the descriptor case.
- For SISO transfer functions or zero-pole-gain models, the poles are the denominator roots. For more information, see `roots`.
- For MIMO transfer functions (or zero-pole-gain models), the poles are returned as the union of the poles for each SISO entry. If some I/O pairs have a common denominator, the roots of such I/O pair denominator are counted only once.

Limitations

- Multiple poles are numerically sensitive and cannot be computed with high accuracy. A pole λ with multiplicity m typically results in a cluster of computed poles distributed on a circle with center λ and radius of order

$$\rho \approx \varepsilon^{1/m},$$

where ϵ is the relative machine precision (`eps`).

For more information on multiple poles, see “Sensitivity of Multiple Roots”.

- If `sys` has internal delays, poles are obtained by first setting all internal delays to zero so that the system has a finite number of poles, thereby creating a zero-order Padé approximation. For some systems, setting delays to zero creates singular algebraic loops, which result in either improper or ill-defined, zero-delay approximations. For these systems, `pole` returns an error.

To assess the stability of models with internal delays, use `step` or `impulse`.

Version History

Introduced before R2006a

See Also

`damp` | `esort` | `dsort` | `pzmap` | `zero` | `step` | `impulse` | `pzplot`

Topics

“Pole and Zero Locations”

“Sensitivity of Multiple Roots”

polyBasis

Polynomial basis functions for tunable gain surface

Syntax

```
shapefcn = polyBasis('canonical', degree)
shapefcn = polyBasis('chebyshev', degree)
shapefcn = polyBasis( ___, nvars)
shapefcn = polyBasis( ___, varnames)
```

Description

You use basis function expansions to parameterize gain surfaces for tuning gain-scheduled controllers. `polyBasis` generates standard polynomial expansions in any number of scheduling variables. Use the resulting functions to create tunable gain surfaces with `tunableSurface`.

`shapefcn = polyBasis('canonical', degree)` generates a function that evaluates the powers of an input variable, x , up to degree:

$$\text{shapefcn}(x) = [x, x^2, \dots, x^{\text{order}}].$$

`shapefcn = polyBasis('chebyshev', degree)` generates a function that evaluates Chebyshev polynomials up to degree:

$$\text{shapefcn}(x) = [T_1(x), \dots, T_{\text{order}}(x)].$$

The Chebyshev polynomials are defined recursively by:

$$T_0(x) = 1; \quad T_1(x) = x; \quad T_{i+1}(x) = 2xT_i(x) - T_{i-1}(x).$$

`shapefcn = polyBasis(___, nvars)` generates an $nvars$ -dimensional polynomial expansion by taking the outer product of $nvars$ 1-D polynomial expansions. The resulting function `shapefcn` takes $nvars$ input arguments and returns a vector with $(\text{degree}+1)^{(nvars-1)}$ entries. For example, for $nvars = 3$ and canonical polynomials,

$$\text{shapefcn}(x, y, z) = [x^i y^j z^k : 0 \leq i, j, k \leq \text{order}, i + j + k > 0].$$

Thus, to specify a bilinear function in two scheduling variables, use:

```
shapefcn = polyBasis('canonical', 1, 2);
```

Using the resulting function with `tunableSurface` defines a variable gain of the form:

$$K(x, y) = K_0 + K_1x + K_2y + K_3xy.$$

Here, x and y are the normalized scheduling variables, whose values lie in the range $[-1, 1]$. (See `tunableSurface` for more information.)

To specify basis functions in multiple scheduling variables where the expansions are different for each variable, use `ndBasis`.

`shapefcn = polyBasis(____, varnames)` specifies variable names. Use this syntax with any of the previous syntaxes to name the variables in `shapefcn`. Using variable names improves readability of the `tunableSurface` object display and of any MATLAB code you generate using `codegen`.

Examples

Polynomial Basis Functions of One Scheduling Variable

Create basis functions for a gain that varies as a cubic function of one scheduling variable.

```
shapefcn = polyBasis('canonical',3);
```

`shapefcn` is a handle to a function of one variable that returns an array of values corresponding to the first three powers of its input. In other words, `shapefcn(x) = [x x^2 x^3]`. For example, examine `shapefcn(-0.2)`.

```
x = -0.2;
shapefcn(x)

ans = 1×3

    -0.2000    0.0400   -0.0080
```

Evaluating `[x x^2 x^3]` for `x = -0.2` returns the same result.

```
[x x^2 x^3]

ans = 1×3

    -0.2000    0.0400   -0.0080
```

Use `shapefcn` as an input argument to `tunableSurface` to define a polynomial gain surface. This `shapefcn` is equivalent to using:

```
shapefcn = @(x) [x x^2 x^3];
```

Chebyshev Basis Functions

Create a set of basis functions that are Chebyshev polynomials of a single variable, up to third degree.

```
shapefcn = polyBasis('chebyshev',3);
```

Bilinear Function of Two Variables

Create basis functions for a bilinear gain surface, `[x, y, xy]`. Name the variables to make the function more readable.

```
shapefcn = polyBasis('canonical',1,2,{'x','y'})
```

```
shapefcn = function_handle with value:  
    @(x,y)utFcnBasisOuterProduct(FDATA_,x,y)
```

Confirm the values returned by `shapefcn` for a particular (x, y) pair.

```
x = 0.2;  
y = -0.5;  
shapefcn(x,y)  
  
ans = 1×3  
  
    0.2000    -0.5000    -0.1000
```

This `shapefcn` is equivalent to:

```
shapefcn = @(x,y)[x,y,x*y];
```

The basis functions of `shapefcn` are first-order in each of the two variables. To create a set of basis functions in different degrees for each variable, use `ndBasis`.

Input Arguments

degree — Degree of expansion

positive integer

Degree of the polynomial expansion, specified as a positive integer.

nvars — Number of variables

1 (default) | positive integer

Number of scheduling variables, specified as a positive integer.

varnames — Variable names

{'x1', 'x2', ...} (default) | character vector | cell array of character vectors

Variable names in the generated function `shapefcn`, specified as a:

- Character vector, for monovariate basis functions.
- Cell array of character vectors, for multivariate basis functions.

If you do not specify `varnames`, then the variables in `shapefcn` are named {'x1', 'x2', ...}.

Example: {'alpha', 'V'}

Output Arguments

shapefcn — Polynomial expansion

function handle

Polynomial expansion, specified as a function handle. `shapefcn` takes as input arguments the number of variables specified by `nvars`. The function evaluates polynomials in those variables up to the specified degree, and returns the resulting values in a vector. When you use `shapefcn` to create

a gain surface, `tunableSurface` automatically generates tunable coefficients for each polynomial term in the vector.

Version History

Introduced in R2015b

See Also

`tunableSurface` | `fourierBasis` | `ndBasis`

predict

Predict state and state estimation error covariance at next time step using extended or unscented Kalman filter, or particle filter

Syntax

```
[PredictedState,PredictedStateCovariance] = predict(obj)
[PredictedState,PredictedStateCovariance] = predict(obj,Us1,...,Usn)
```

Description

The `predict` command predicts the state and state estimation error covariance of an `extendedKalmanFilter`, `unscentedKalmanFilter` or `particleFilter` object at the next time step. To implement the extended or unscented Kalman filter algorithms, use the `predict` and `correct` commands together. If the current output measurement exists, you can use `predict` and `correct`. If the measurement is missing, you can only use `predict`. For information about the order in which to use the commands, see “Using `predict` and `correct` Commands” on page 2-1034.

`[PredictedState,PredictedStateCovariance] = predict(obj)` predicts state estimate and state estimation error covariance of an extended or unscented Kalman filter, or particle filter object `obj` at the next time step.

You create `obj` using the `extendedKalmanFilter`, `unscentedKalmanFilter` or `particleFilter` commands. You specify the state transition function and measurement function of your nonlinear system in `obj`. You also specify whether the process and measurement noise terms are additive or nonadditive in these functions. The `State` property of the object stores the latest estimated state value. Assume that at time step k , `obj.State` is $\hat{x}[k|k]$. This value is the state estimate for time k , estimated using measured outputs until time k . When you use the `predict` command, the software returns $\hat{x}[k+1|k]$ in the `PredictedState` output. Where $\hat{x}[k+1|k]$ is the state estimate for time $k+1$, estimated using measured output until time k . The command returns the state estimation error covariance of $\hat{x}[k+1|k]$ in the `PredictedStateCovariance` output. The software also updates the `State` and `StateCovariance` properties of `obj` with these corrected values.

Use this syntax if the state transition function f that you specified in `obj.StateTransitionFcn` has one of the following forms:

- $x(k) = f(x(k-1))$ — for additive process noise.
- $x(k) = f(x(k-1),w(k-1))$ — for nonadditive process noise.

Where x and w are the state and process noise of the system. The only inputs to f are the states and process noise.

`[PredictedState,PredictedStateCovariance] = predict(obj,Us1,...,Usn)` specifies additional input arguments, if the state transition function of the system requires these inputs. You can specify multiple arguments.

Use this syntax if your state transition function f has one of the following forms:

- $x(k) = f(x(k-1), U_{s1}, \dots, U_{sn})$ — for additive process noise.
- $x(k) = f(x(k-1), w(k-1), U_{s1}, \dots, U_{sn})$ — for nonadditive process noise.

Examples

Estimate States Online Using Unscented Kalman Filter

Estimate the states of a van der Pol oscillator using an unscented Kalman filter algorithm and measured output data. The oscillator has two states and one output.

Create an unscented Kalman filter object for the oscillator. Use previously written and saved state transition and measurement functions, `vdpStateFcn.m` and `vdpMeasurementFcn.m`. These functions describe a discrete-approximation to a van der Pol oscillator with nonlinearity parameter, `mu`, equal to 1. The functions assume additive process and measurement noise in the system. Specify the initial state values for the two states as `[1;0]`. This is the guess for the state value at initial time k , using knowledge of system outputs until time $k-1$, $\hat{x}[k|k-1]$.

```
obj = unscentedKalmanFilter(@vdpStateFcn,@vdpMeasurementFcn,[1;0]);
```

Load the measured output data, `y`, from the oscillator. In this example, use simulated static data for illustration. The data is stored in the `vdp_data.mat` file.

```
load vdp_data.mat y
```

Specify the process noise and measurement noise covariances of the oscillator.

```
obj.ProcessNoise = 0.01;
obj.MeasurementNoise = 0.16;
```

Initialize arrays to capture results of the estimation.

```
residBuf = [];
xcorBuf = [];
xpredBuf = [];
```

Implement the unscented Kalman filter algorithm to estimate the states of the oscillator by using the `correct` and `predict` commands. You first correct $\hat{x}[k|k-1]$ using measurements at time k to get $\hat{x}[k|k]$. Then, you predict the state value at next time step, $\hat{x}[k+1|k]$, using $\hat{x}[k|k]$, the state estimate at time step k that is estimated using measurements until time k .

To simulate real-time data measurements, use the measured data one time step at a time. Compute the residual between the predicted and actual measurement to assess how well the filter is performing and converging. Computing the residual is an optional step. When you use `residual`, place the command immediately before the `correct` command. If the prediction matches the measurement, the residual is zero.

After you perform the real-time commands for the time step, buffer the results so that you can plot them after the run is complete.

```
for k = 1:size(y)
    [Residual,ResidualCovariance] = residual(obj,y(k));
    [CorrectedState,CorrectedStateCovariance] = correct(obj,y(k));
    [PredictedState,PredictedStateCovariance] = predict(obj);
```

```

    residBuf(k,:) = Residual;
    xcorBuf(k,:) = CorrectedState';
    xpredBuf(k,:) = PredictedState';
end

```

When you use the `correct` command, `obj.State` and `obj.StateCovariance` are updated with the corrected state and state estimation error covariance values for time step k , `CorrectedState` and `CorrectedStateCovariance`. When you use the `predict` command, `obj.State` and `obj.StateCovariance` are updated with the predicted values for time step $k+1$, `PredictedState` and `PredictedStateCovariance`.

In this example, you used `correct` before `predict` because the initial state value was $\hat{x}[k|k-1]$, a guess for the state value at initial time k using system outputs until time $k-1$. If your initial state value is $\hat{x}[k-1|k-1]$, the value at previous time $k-1$ using measurement until $k-1$, then use the `predict` command first. For more information about the order of using `predict` and `correct`, see “Using `predict` and `correct` Commands” on page 2-1034.

Plot the estimated states, using the postcorrection values.

```

plot(xcorBuf(:,1), xcorBuf(:,2))
title('Estimated States')

```

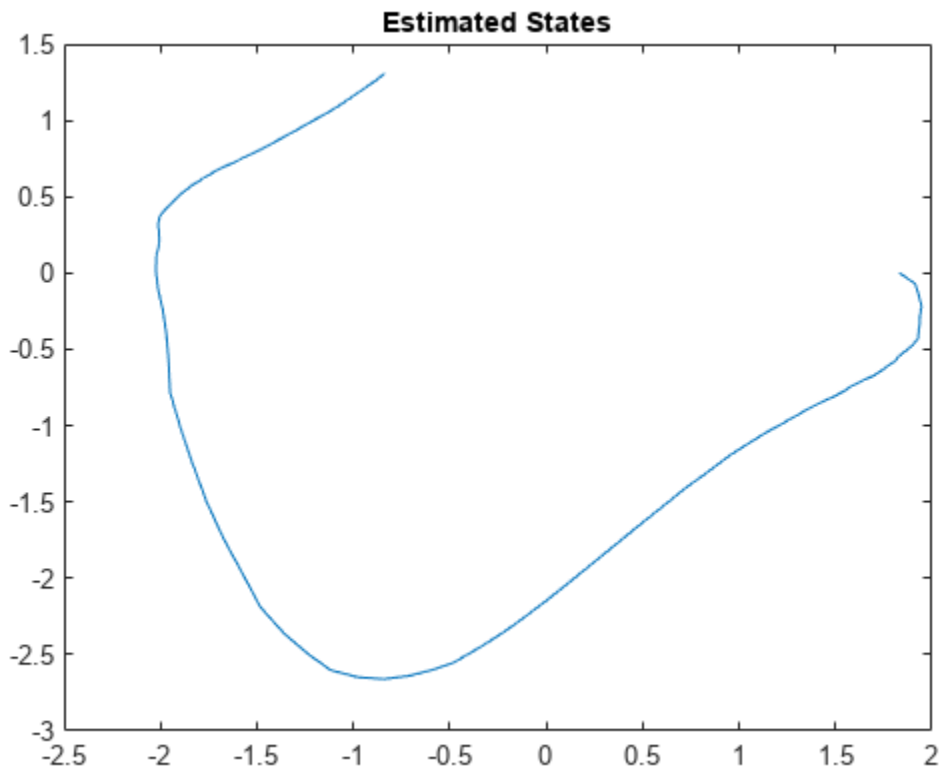

Plot the actual measurement, the corrected estimated measurement, and the residual. For the measurement function in `vdpMeasurementFcn`, the measurement is the first state.

```

M = [y,xcorBuf(:,1),residBuf];
plot(M)

```



```

grid on
title('Actual and Estimated Measurements, Residual')
legend('Measured','Estimated','Residual')

```

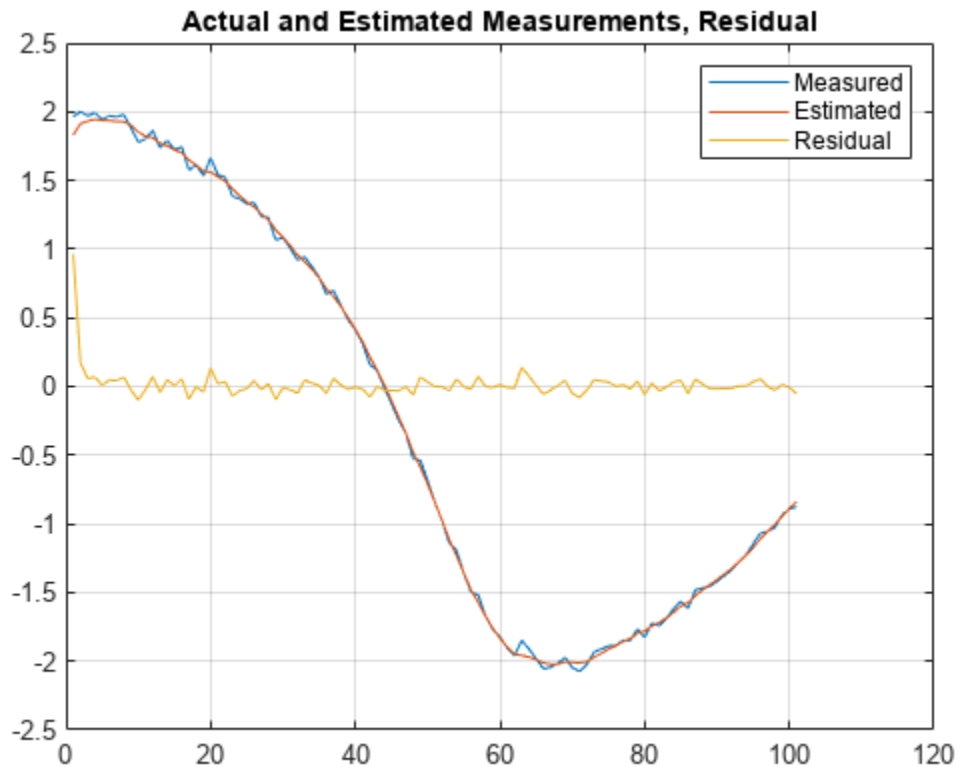

The estimate tracks the measurement closely. After the initial transient, the residual remains relatively small throughout the run.

Estimate States Online using Particle Filter

Load the van der Pol ODE data, and specify the sample time.

`vdpODEdata.mat` contains a simulation of the van der Pol ODE with nonlinearity parameter $\mu=1$, using `ode45`, with initial conditions $[2;0]$. The true state was extracted with sample time $dt = 0.05$.

```
addpath(fullfile(matlabroot,'examples','control','main')) % add example data
```

```
load ('vdpODEdata.mat','xTrue','dt')
tSpan = 0:dt:5;
```

Get the measurements. For this example, a sensor measures the first state with a Gaussian noise with standard deviation 0.04 .

```
sqrR = 0.04;
yMeas = xTrue(:,1) + sqrR*randn(numel(tSpan),1);
```

Create a particle filter, and set the state transition and measurement likelihood functions.

```
myPF = particleFilter(@vdpParticleFilterStateFcn,@vdpMeasurementLikelihoodFcn);
```

Initialize the particle filter at state [2; 0] with unit covariance, and use 1000 particles.

```
initialize(myPF,1000,[2;0],eye(2));
```

Pick the mean state estimation and systematic resampling methods.

```
myPF.StateEstimationMethod = 'mean';
myPF.ResamplingMethod = 'systematic';
```

Estimate the states using the correct and predict commands, and store the estimated states.

```
xEst = zeros(size(xTrue));
for k=1:size(xTrue,1)
    xEst(k,:) = correct(myPF,yMeas(k));
    predict(myPF);
end
```

Plot the results, and compare the estimated and true states.

```
figure(1)
plot(xTrue(:,1),xTrue(:,2),'x',xEst(:,1),xEst(:,2),'ro')
legend('True','Estimated')
```

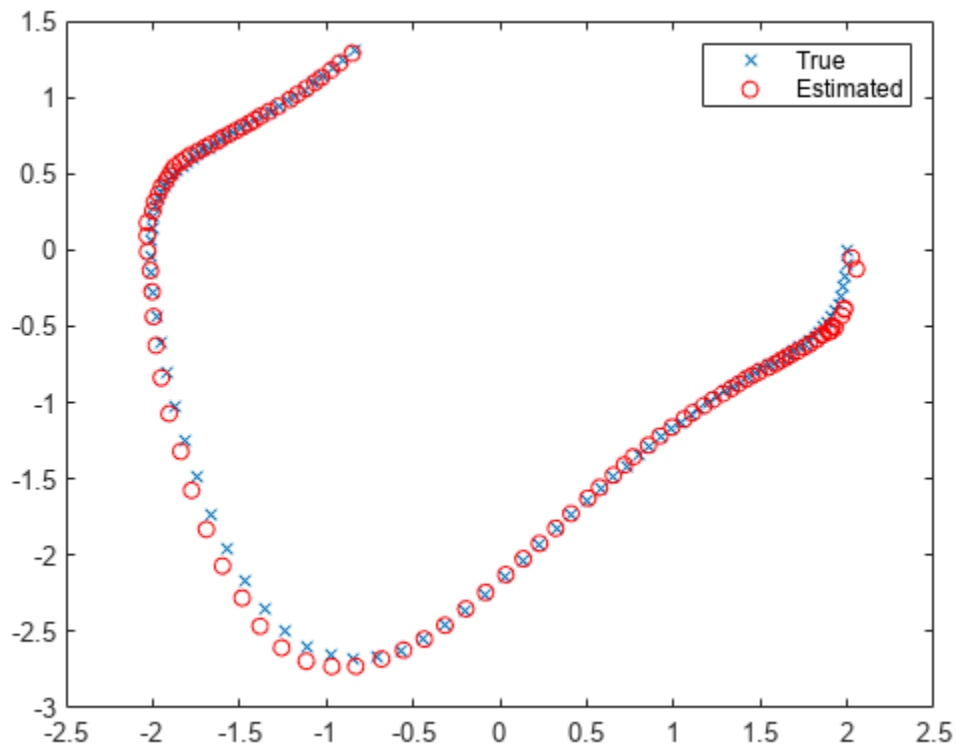

```
rmpath(fullfile(matlabroot,'examples','control','main')) % remove example data
```

Specify State Transition and Measurement Functions with Additional Inputs

Consider a nonlinear system with input u whose state x and measurement y evolve according to the following state transition and measurement equations:

$$x[k] = \sqrt{x[k-1]} + u[k-1] + w[k-1]$$

$$y[k] = x[k] + 2 * u[k] + v[k]^2$$

The process noise w of the system is additive while the measurement noise v is nonadditive.

Create the state transition function and measurement function for the system. Specify the functions with an additional input u .

```
f = @(x,u)(sqrt(x+u));
h = @(x,v,u)(x+2*u+v^2);
```

f and h are function handles to the anonymous functions that store the state transition and measurement functions, respectively. In the measurement function, because the measurement noise is nonadditive, v is also specified as an input. Note that v is specified as an input before the additional input u .

Create an extended Kalman filter object for estimating the state of the nonlinear system using the specified functions. Specify the initial value of the state as 1 and the measurement noise as nonadditive.

```
obj = extendedKalmanFilter(f,h,1,'HasAdditiveMeasurementNoise',false);
```

Specify the measurement noise covariance.

```
obj.MeasurementNoise = 0.01;
```

You can now estimate the state of the system using the `predict` and `correct` commands. You pass the values of u to `predict` and `correct`, which in turn pass them to the state transition and measurement functions, respectively.

Correct the state estimate with measurement $y[k]=0.8$ and input $u[k]=0.2$ at time step k .

```
correct(obj,0.8,0.2)
```

Predict the state at the next time step, given $u[k]=0.2$.

```
predict(obj,0.2)
```

Retrieve the error, or *residual*, between the prediction and the measurement.

```
[Residual, ResidualCovariance] = residual(obj,0.8,0.2);
```

Input Arguments

obj — Extended or unscented Kalman filter, or particle filter object

extendedKalmanFilter object | unscentedKalmanFilter object | particleFilter object

Extended or unscented Kalman filter, or particle filter object for online state estimation, created using one of the following commands:

- `extendedKalmanFilter` — Uses the extended Kalman filter algorithm.
- `unscentedKalmanFilter` — Uses the unscented Kalman filter algorithm.
- `particleFilter` — Uses the particle filter algorithm.

Us1, . . . Usn — Additional input arguments to state transition function

input arguments of any type

Additional input arguments to state transition function, specified as input arguments of any type. The state transition function, f , is specified in the `StateTransitionFcn` property of the object. If the function requires input arguments in addition to the state and process noise values, you specify these inputs in the `predict` command syntax.

For example, suppose that your state transition function calculates the predicted state x at time step k using system inputs $u(k-1)$ and time $k-1$, in addition to the state $x(k-1)$:

$$x(k) = f(x(k-1), u(k-1), k-1)$$

Then when you perform online state estimation at time step k , specify these additional inputs in the `predict` command syntax:

```
[PredictedState, PredictedStateCovariance] = predict(obj, u(k-1), k-1);
```

Output Arguments

PredictedState — Predicted state estimate

vector

Predicted state estimate, returned as a vector of size M , where M is the number of states of the system. If you specify the initial states of `obj` as a column vector then M is returned as a column vector, otherwise M is returned as a row vector.

For information about how to specify the initial states of the object, see the `extendedKalmanFilter`, `unscentedKalmanFilter` and `particleFilter` reference pages.

PredictedStateCovariance — Predicted state estimation error covariance

matrix

Predicted state estimation error covariance, returned as an M -by- M matrix, where M is the number of states of the system.

More About

Using `predict` and `correct` Commands

After you have created an extended or unscented Kalman filter, or particle filter object, `obj`, to implement the estimation algorithms, use the `correct` and `predict` commands together.

At time step k , `correct` command returns the corrected value of states and state estimation error covariance using measured system outputs $y[k]$ at the same time step. If your measurement function has additional input arguments U_m , you specify these as inputs to the `correct` command. The command passes these values to the measurement function.

```
[CorrectedState,CorrectedCovariance] = correct(obj,y,Um)
```

The `correct` command updates the `State` and `StateCovariance` properties of the object with the estimated values, `CorrectedState` and `CorrectedCovariance`.

The `predict` command returns the prediction of state and state estimation error covariance at the next time step. If your state transition function has additional input arguments U_s , you specify these as inputs to the `predict` command. The command passes these values to the state transition function.

```
[PredictedState,PredictedCovariance] = predict(obj,Us)
```

The `predict` command updates the `State` and `StateCovariance` properties of the object with the predicted values, `PredictedState` and `PredictedCovariance`.

If the current output measurement exists at a given time step, you can use `correct` and `predict`. If the measurement is missing, you can only use `predict`. For details about how these commands implement the algorithms, see “Extended and Unscented Kalman Filter Algorithms for Online State Estimation”.

The order in which you implement the commands depends on the availability of measured data y , U_s , and U_m for your system:

- **correct then predict** — Assume that at time step k , the value of `obj.State` is $\hat{x}[k|k-1]$. This value is the state of the system at time k , estimated using measured outputs until time $k-1$. You also have the measured output $y[k]$ and inputs $U_s[k]$ and $U_m[k]$ at the same time step.

Then you first execute the `correct` command with measured system data $y[k]$ and additional inputs $U_m[k]$. The command updates the value of `obj.State` to be $\hat{x}[k|k]$, the state estimate for time k , estimated using measured outputs up to time k . When you then execute the `predict` command with input $U_s[k]$, `obj.State` now stores $\hat{x}[k+1|k]$. The algorithm uses this state value as an input to the `correct` command in the next time step.

- **predict then correct** — Assume that at time step k , the value of `obj.State` is $\hat{x}[k-1|k-1]$. You also have the measured output $y[k]$ and input $U_m[k]$ at the same time step but you have $U_s[k-1]$ from the previous time step.

Then you first execute the `predict` command with input $U_s[k-1]$. The command updates the value of `obj.State` to $\hat{x}[k|k-1]$. When you then execute the `correct` command with input arguments $y[k]$ and $U_m[k]$, `obj.State` is updated with $\hat{x}[k|k]$. The algorithm uses this state value as an input to the `predict` command in the next time step.

Thus, while in both cases the state estimate for time k , $\hat{x}[k|k]$ is the same, if at time k you do not have access to the current state transition function inputs $U_s[k]$, and instead have $U_s[k-1]$, then use `predict` first and then `correct`.

For an example of estimating states using the `predict` and `correct` commands, see “Estimate States Online Using Unscented Kalman Filter” on page 2-1029 or “Estimate States Online using Particle Filter” on page 2-1031.

Version History

Introduced in R2016b

See Also

`correct` | `clone` | `extendedKalmanFilter` | `unscentedKalmanFilter` | `particleFilter` | `initialize` | `residual`

Topics

“Nonlinear State Estimation Using Unscented Kalman Filter and Particle Filter”

“Generate Code for Online State Estimation in MATLAB”

“Extended and Unscented Kalman Filter Algorithms for Online State Estimation”

prescale

Optimal scaling of state-space models

Syntax

```
scaledsys = prescale(sys)
scaledsys = prescale(sys, focus)
[scaledsys, info] = prescale(...)
prescale(sys)
```

Description

`scaledsys = prescale(sys)` scales the entries of the state vector of a state-space model `sys` to maximize the accuracy of subsequent frequency-domain analysis. The scaled model `scaledsys` is equivalent to `sys`.

`scaledsys = prescale(sys, focus)` specifies a frequency interval `focus = {fmin, fmax}` (in rad/TimeUnit, where `TimeUnit` is the system's time units specified in the `TimeUnit` property of `sys`) over which to maximize accuracy. This is useful when `sys` has a combination of slow and fast dynamics and scaling cannot achieve high accuracy over the entire dynamic range. By default, `prescale` attempts to maximize accuracy in the frequency band with dominant dynamics.

`[scaledsys, info] = prescale(...)` also returns a structure `info` with the fields shown in the following table.

SL	Left scaling factors
SR	Right scaling factors
Freqs	Frequencies used to test accuracy
RelAcc	Guaranteed relative accuracy at these frequencies

The test frequencies lie in the frequency interval `focus` when specified. The scaled state-space matrices are

$$A_s = T_L A T_R$$

$$B_s = T_L B$$

$$C_s = C T_R$$

$$E_s = T_L E T_R$$

where $T_L = \text{diag}(SL)$ and $T_R = \text{diag}(SR)$. T_L and T_R are inverse of each other for explicit models ($E = []$).

`prescale(sys)` opens an interactive GUI for:

- Visualizing accuracy trade-offs for `sys`.
- Adjusting the frequency interval where the accuracy of `sys` is maximized.

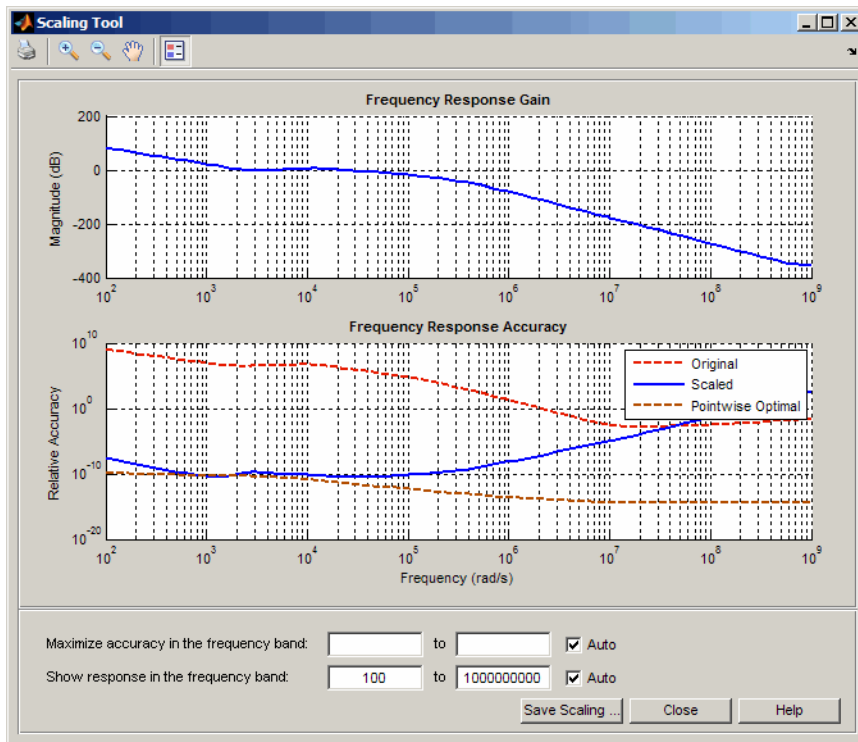

For more information on scaling and using the Scaling Tool GUI, see “Scaling State-Space Models”.

Tips

Most frequency-domain analysis commands perform automatic scaling equivalent to `scaledsys = prescale(sys)`.

You do not need to scale for time-domain simulations and doing so may invalidate the initial condition `x0` used in `initial` and `lsim` simulations.

Version History

Introduced in R2008b

See Also

ss

pzmap

Pole-zero plot of dynamic system

Syntax

```
pzmap(sys)
pzmap(sys1, sys2, ..., sysN)
```

```
[p, z] = pzmap(sys)
```

Description

`pzmap(sys)` creates a pole-zero plot of the continuous or discrete-time dynamic system model `sys`. `x` and `o` indicates the poles and zeros respectively, as shown in the following figure.

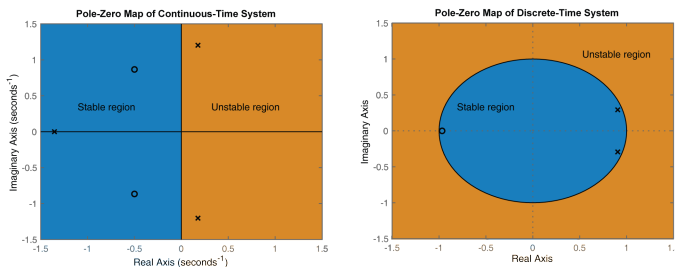

From the figure above, an open-loop linear time-invariant system is stable if:

- In continuous-time, all the poles on the complex s -plane must be in the left-half plane (blue region) to ensure stability. The system is marginally stable if distinct poles lie on the imaginary axis, that is, the real parts of the poles are zero.
- In discrete-time, all the poles in the complex z -plane must lie inside the unit circle (blue region). The system is marginally stable if it has one or more poles lying on the unit circle.

`pzmap(sys1, sys2, ..., sysN)` creates the pole-zero plot of multiple models on a single figure. The models can have different numbers of inputs and outputs and can be a mix of continuous and discrete systems. For SISO systems, `pzmap` plots the system poles and zeros. For MIMO systems, `pzmap` plots the system poles and transmission zeros.

`[p, z] = pzmap(sys)` returns the system poles and transmission zeros as column vectors `p` and `z`. The pole-zero plot is not displayed on the screen.

Examples

Pole-Zero Plot of Dynamic System

Plot the poles and zeros of the continuous-time system represented by the following transfer function:

$$H(s) = \frac{2s^2 + 5s + 1}{s^2 + 3s + 5}$$

```
H = tf([2 5 1],[1 3 5]);
pzmap(H)
grid on
```

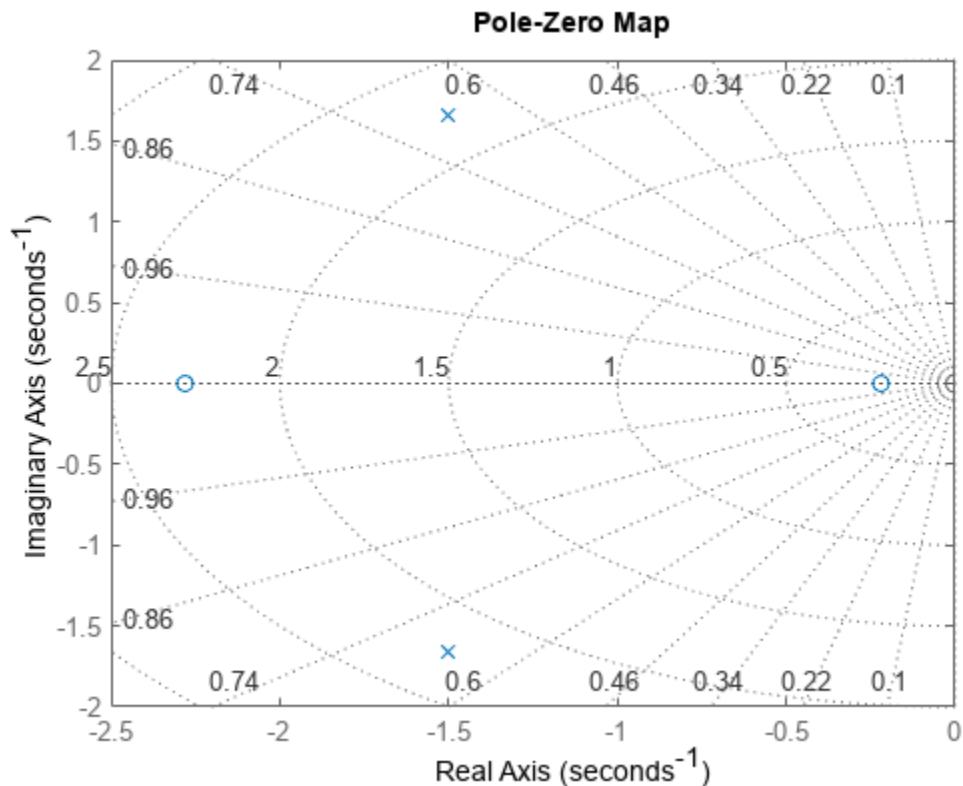

Turning on the grid displays lines of constant damping ratio (zeta) and lines of constant natural frequency (wn). This system has two real zeros, marked by o on the plot. The system also has a pair of complex poles, marked by x.

Pole-Zero Plot of Identified System

Plot the pole-zero map of a discrete time identified state-space (idss) model. In practice you can obtain an idss model by estimation based on input-output measurements of a system. For this example, create one from state-space data.

```
A = [0.1 0; 0.2 -0.9];
B = [.1 ; 0.1];
C = [10 5];
D = [0];
sys = idss(A,B,C,D, 'Ts', 0.1);
```

Examine the pole-zero map.

```
pzmap(sys)
```

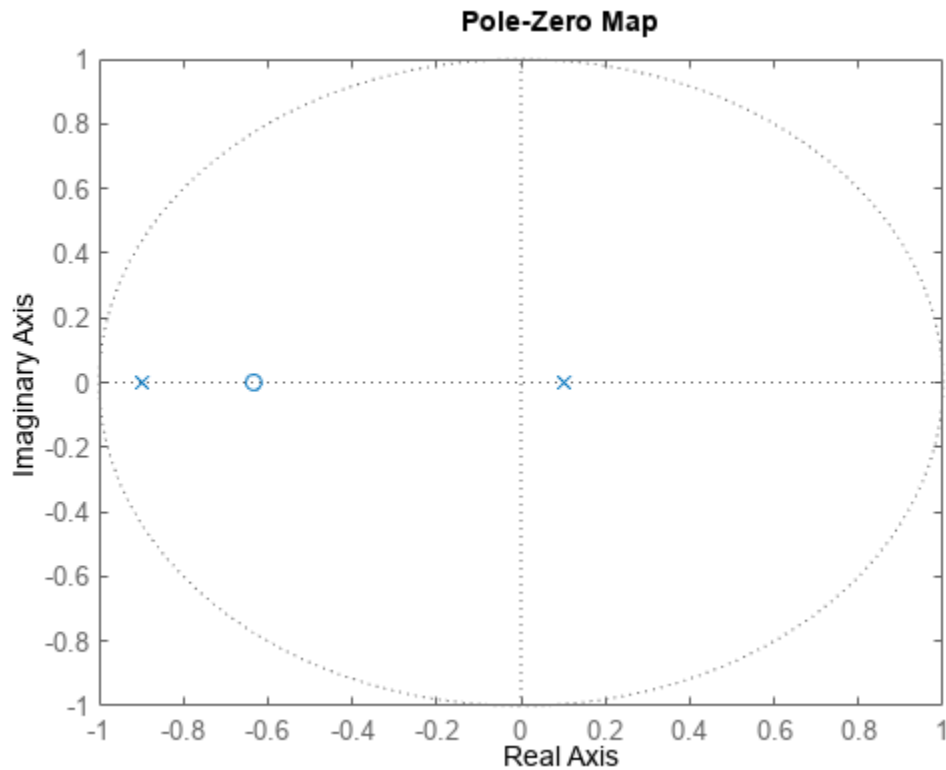

System poles are marked by x, and zeros are marked by o.

Pole-Zero Map of Multiple Models

For this example, load a 3-by-1 array of transfer function models.

```
load('tfArray.mat', 'sys');
size(sys)
```

```
3x1 array of transfer functions.
Each model has 1 outputs and 1 inputs.
```

Plot the poles and zeros of each model in the array with distinct colors. For this example, use red for the first model, green for the second and blue for the third model in the array.

```
pzmap(sys(:,:,1), 'r', sys(:,:,2), 'g', sys(:,:,3), 'b')
sgrid
```

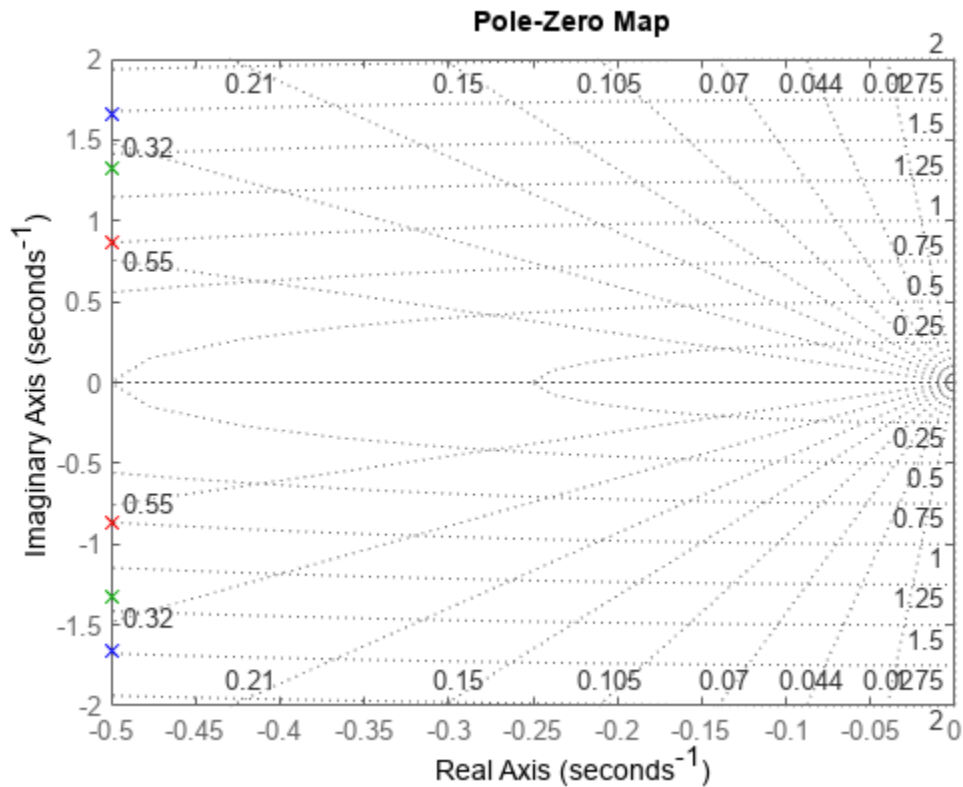

sgrid plots lines of constant damping ratio and natural frequency in the s-plane of the pole-zero plot.

Poles and Zeros of Transfer Function

Use pzmap to calculate the poles and zeros of the following transfer function:

$$\text{sys}(s) = \frac{4.2s^2 + 0.25s - 0.004}{s^2 + 9.6s + 17}$$

```
sys = tf([4.2,0.25,-0.004],[1,9.6,17]);
[p,z] = pzmap(sys)
```

p = 2×1

```
-7.2576
-2.3424
```

z = 2×1

```
-0.0726
0.0131
```

Identify Near-Canceling Pole-Zero Pairs

This example uses a model of a building with eight floors, each with three degrees of freedom: two displacements and one rotation. The I/O relationship for any one of these displacements is represented as a 48-state model, where each state represents a displacement or its rate of change (velocity).

Load the building model.

```
load('building.mat');
size(G)
```

State-space model with 1 outputs, 1 inputs, and 48 states.

Plot the poles and zeros of the system.

```
pzmap(G)
```

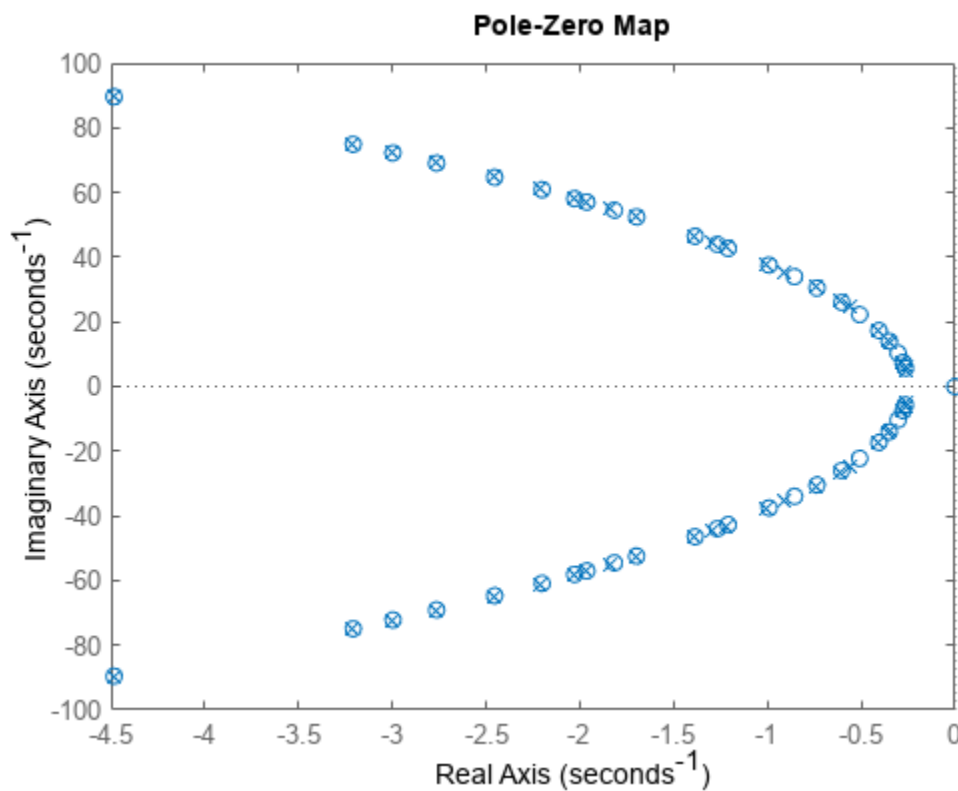

From the plot, observe that there are numerous near-canceling pole-zero pairs that could be potentially eliminated to simplify the model, with no effect on the overall model response. `pzmap` is useful to visually identify such near-canceling pole-zero pairs to perform pole-zero simplification.

Input Arguments

sys — Dynamic system

dynamic system model | model array

Dynamic system, specified as a dynamic system model or model array. Dynamic systems that you can use include continuous-time or discrete-time numeric LTI models such as `tf`, `zpk`, or `ss` models.

If `sys` is an array of models, `pzmap` plots all the poles and zeros of every model in the array on the same plot.

Output Arguments

p — Poles of the system

column vector

Poles of the system, returned as a column vector, in order of its increasing natural frequency. `p` is the same as the output of `pole(sys)`, except for the order.

z — Transmission zeros of the system

column vector

Transmission zeros of the system, returned as a column vector. `z` is the same as the output of `tzero(sys)`.

Tips

- Use the functions `sgrid` or `zgrid` to plot lines of constant damping ratio and natural frequency in the s - or z -plane on the pole-zero plot.
- For MIMO models, `pzmap` displays all system poles and transmission zeros on a single plot. To map poles and zeros for individual I/O pairs, use `iopzmap`.
- For additional options to customize the appearance of the pole-zero plot, use `pzplot`.

Version History

Introduced before R2006a

See Also

`damp` | `esort` | `dsort` | `pole` | `rlocus` | `sgrid` | `zgrid` | `zero` | `iopzmap` | `pzplot`

pzplot

Pole-zero plot of dynamic system model with additional plot customization options

Syntax

```
h = pzplot(sys)
h = pzplot(sys1,sys2,...,sysN)
h = pzplot(sys1,LineStyle1,...,sysN,LineStyleN)
h = pzplot(ax,...)
h = pzplot(...,plotoptions)
```

Description

`pzplot` lets you plot pole-zero maps with a broader range of plot customization options than `pzmap`. You can use `pzplot` to obtain the plot handle and use it to customize the plot, such as modify the axes labels, limits and units. You can also use `pzplot` to draw a pole-zero plot on an existing set of axes represented by an axes handle. To customize an existing plot using the plot handle:

- 1 Obtain the plot handle
- 2 Use `getoptions` to obtain the option set
- 3 Update the plot using `setoptions` to modify the required options

For more information, see “Customizing Response Plots from the Command Line”. To create pole-zero maps with default options or to extract pole-zero data, use `pzmap`.

`h = pzplot(sys)` plots the poles and transmission zeros of the dynamic system model `sys` and returns the plot handle `h` to the plot. `x` and `o` indicates poles and zeros respectively.

`h = pzplot(sys1,sys2,...,sysN)` displays the poles and transmission zeros of multiple models on a single plot. You can specify distinct colors for each model individually.

`h = pzplot(sys1,LineStyle1,...,sysN,LineStyleN)` sets the line style, marker type, and color for the plot of each system. All systems must have the same number of inputs and outputs to use this syntax.

`h = pzplot(ax,...)` plots into the axes specified by `ax` instead of the current axis `gca`.

`h = pzplot(...,plotoptions)` plots the poles and transmission zeros with the options specified in `plotoptions`. For more information on the ways to change properties of your plots, see “Ways to Customize Plots”.

Examples

Pole-Zero Plot with Custom Plot Title

Plot the poles and zeros of the continuous-time system represented by the following transfer function:

$$\text{sys}(s) = \frac{2s^2 + 5s + 1}{s^2 + 3s + 5}$$

```

sys = tf([2 5 1],[1 3 5]);
h = pzplot(sys);
grid on

```

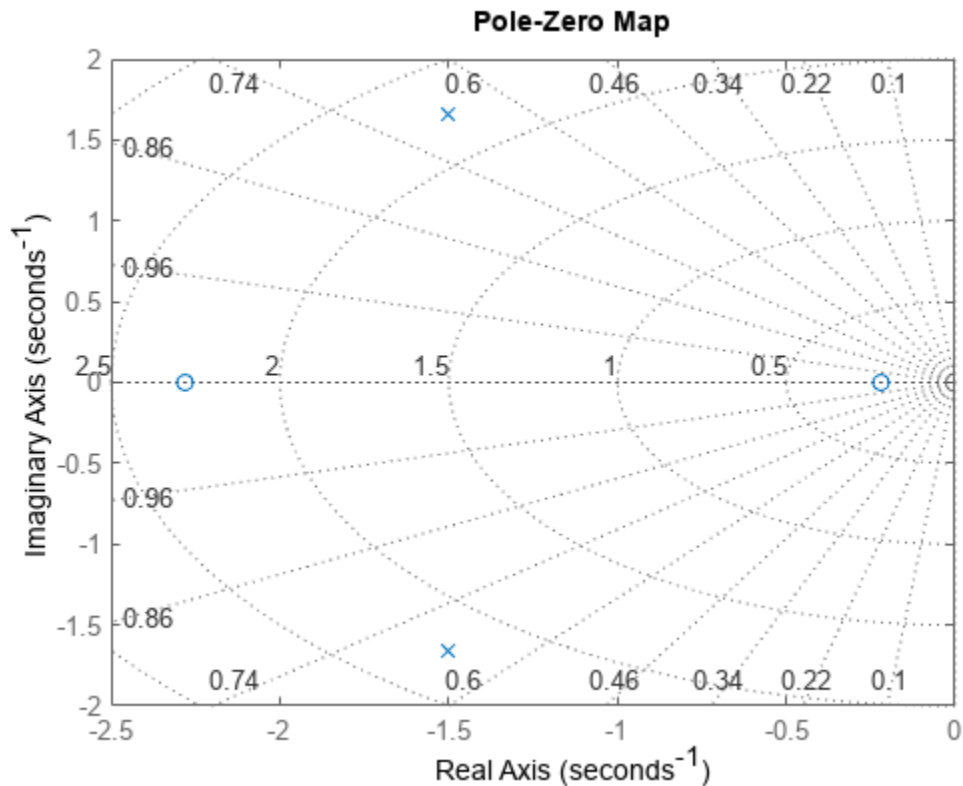

Turning on the grid displays lines of constant damping ratio (ζ) and lines of constant natural frequency (ω_n). This system has two real zeros, marked by o on the plot. The system also has a pair of complex poles, marked by x.

Change the color of the plot title. To do so, use the plot handle, h.

```

p = getoptions(h);
p.Title.Color = [1,0,0];
setoptions(h,p);

```

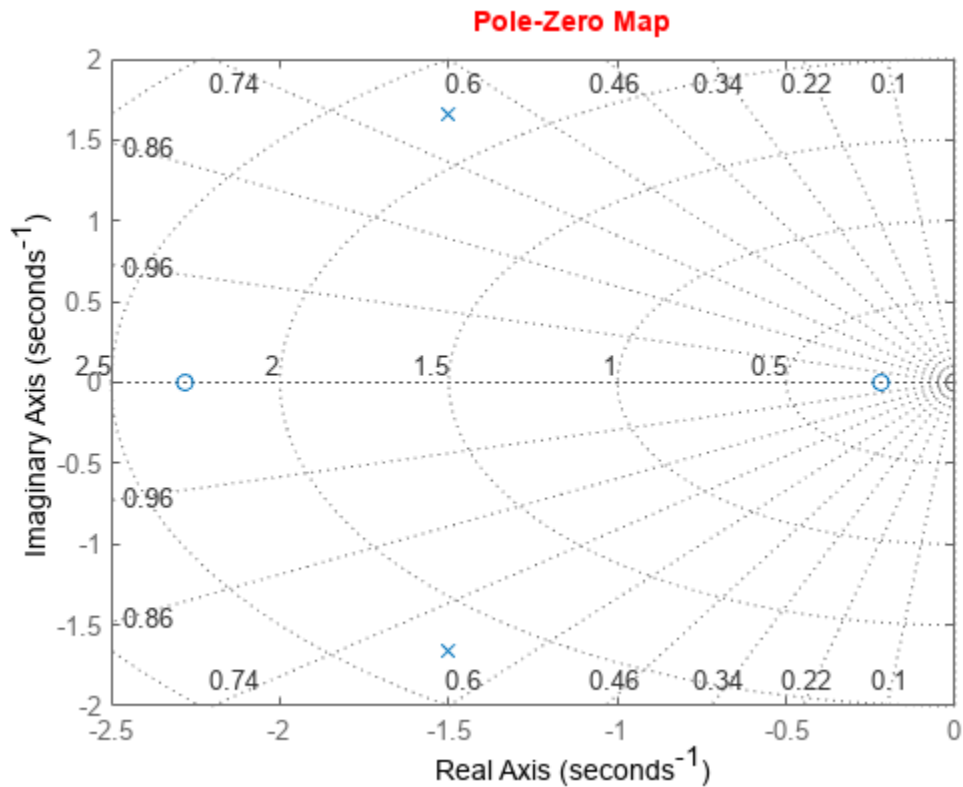
Pole-Zero Plot of Multiple Models

For this example, load a 3-by-1 array of transfer function models.

```
load('tfArrayMargin.mat', 'sys');
size(sys)
```

3x1 array of transfer functions.
Each model has 1 outputs and 1 inputs.

Plot the poles and zeros of the model array. Define the colors for each model. For this example, use red for the first model, green for the second and blue for the third model in the array.

```
pzplot(sys(:,:,1), 'r', sys(:,:,2), 'g', sys(:,:,3), 'b');
```

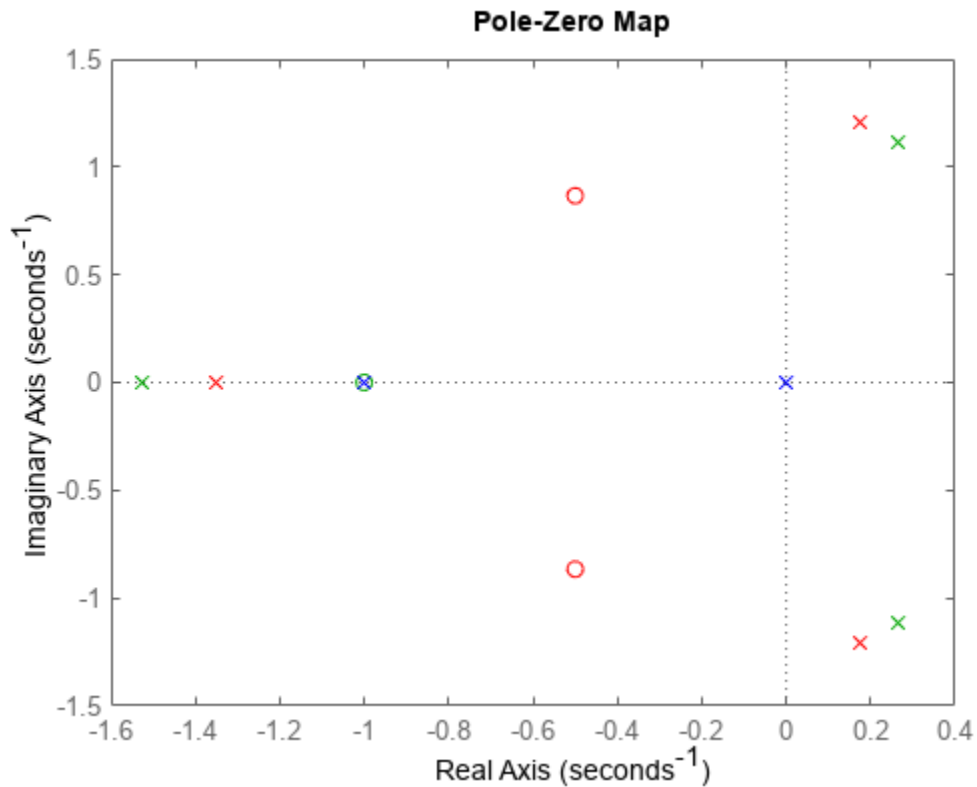

Pole-Zero Plot with Custom Options

Plot the poles and zeros of the continuous-time system represented by the following transfer function with a custom option set:

$$\text{sys}(s) = \frac{2s^2 + 5s + 1}{s^2 + 3s + 5}$$

Create the custom option set using `pzoptions`.

```
plotoptions = pzoptions;
```

For this example, specify the grid to be visible.

```
plotoptions.Grid = 'on';
```

Use the specified options to create a pole-zero map of the transfer function.

```
h = pzplot(tf([2 5 1],[1 3 5]),plotoptions);
```

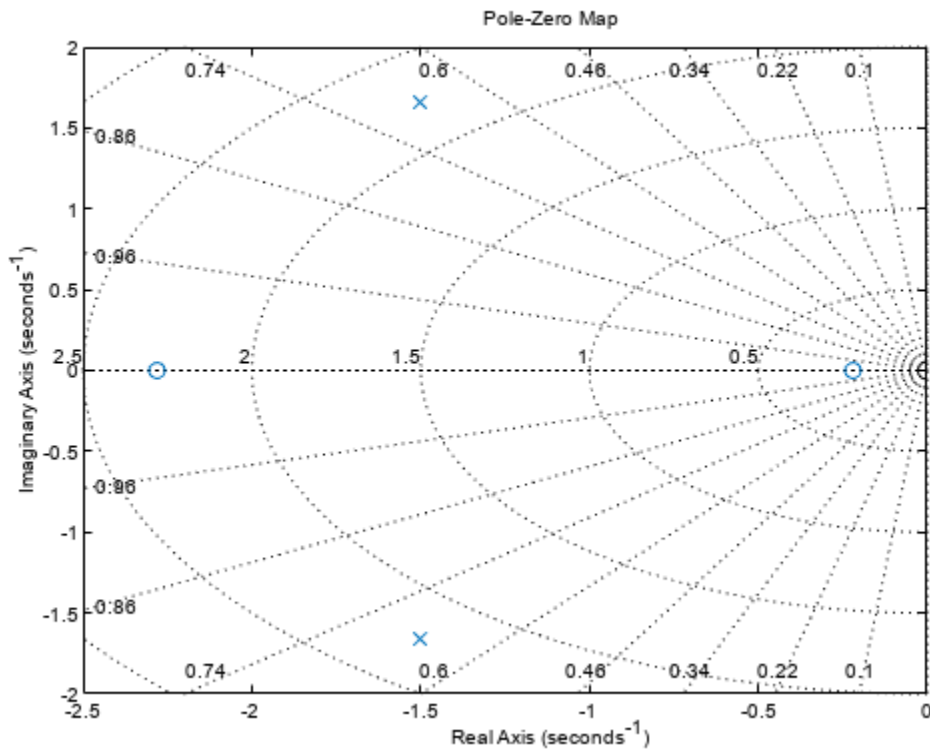

Turning on the grid displays lines of constant damping ratio (ζ) and lines of constant natural frequency (ω_n). This system has two real zeros, marked by `o` on the plot. The system also has a pair of complex poles, marked by `x`.

Input Arguments

sys — Dynamic system

dynamic system model | model array

Dynamic system, specified as a SISO or MIMO dynamic system model, or an array of SISO or MIMO dynamic system models. Dynamic systems that you can use include continuous-time or discrete-time numeric LTI models such as `tf`, `zpk`, or `ss` models.

If `sys` is a generalized state-space model `genss` or an uncertain state-space model `uss`, `pzplot` returns the poles and transmission zeros of the current or nominal value of `sys`. If `sys` is an array of models, `pzplot` plots the poles and zeros of each model in the array on the same diagram.

LineStyle — Line style, marker, and color

character vector | string

Line style, marker, and color, specified as a character vector or string containing symbols. The symbols can appear in any order. You do not need to specify all three characteristics (line style, marker, and color). For example, if you omit the line style and specify the marker, then the plot shows only the marker and no line.

Example: `'--or'` is a red dashed line with circle markers

Line Style	Description
-	Solid line
--	Dashed line
:	Dotted line
-.	Dash-dot line

Marker	Description
'o'	Circle
'+'	Plus sign
'*'	Asterisk
'.'	Point
'x'	Cross
'_'	Horizontal line
' '	Vertical line
's'	Square
'd'	Diamond
'^'	Upward-pointing triangle
'v'	Downward-pointing triangle
'>'	Right-pointing triangle
'<'	Left-pointing triangle
'p'	Pentagram
'h'	Hexagram

Color	Description
y	yellow
m	magenta
c	cyan
r	red
g	green
b	blue
w	white
k	black

ax — Axes handle

axes object

Axes handle, specified as an axes object. If you do not specify the axes object, then `pzplot` uses the current axes `gca` to plot the poles and zeros of the system.

plotoptions — Pole-zero plot options

options object

Pole-zero plot options, specified as an options object. See `pzoptions` for a list of available plot options.

Output Arguments

h — Pole-zero plot options handle

scalar

Pole-zero plot options handle, returned as a scalar. Use `h` to query and modify properties of your pole-zero plot. You can use this handle to customize the plot with the `getoptions` and `setoptions` commands.

Tips

- Use `sgrid` or `zgrid` to plot lines of constant damping ratio and natural frequency in the s - or z -plane.

Version History

Introduced before R2006a

See Also

`getoptions` | `pzmap` | `setoptions` | `iopzplot` | `pzoptions`

Topics

“Ways to Customize Plots”

pzoptions

Create list of pole/zero plot options

Description

Use the `pzoptions` command to create a `PZOptions` object to customize your pole/zero plot appearance. You can also use the command to override the plot preference settings in the MATLAB session in which you create the pole/zero plots.

Creation

Syntax

```
plotoptions = pzoptions  
plotoptions = pzoptions('cstprefs')
```

Description

`plotoptions = pzoptions` returns a default set of plot options for use with the `pzplot` and `iopzplot` commands. You can use these options to customize the pole/zero plot appearance using the command line. This syntax is useful when you want to write a script to generate plots that look the same regardless of the preference settings of the MATLAB session in which you run the script.

`plotoptions = pzoptions('cstprefs')` initializes the plot options with the options you selected in the Control System Toolbox and System Identification Toolbox Preferences Editor. For more information about the editor, see “Toolbox Preferences Editor”. This syntax is useful when you want to change a few plot options but otherwise use your default preferences. A script that uses this syntax may generate results that look different when run in a session with different preferences.

Properties

FreqUnits — Frequency units

'rad/s' (default)

Frequency units, specified as one of the following values:

- 'Hz'
- 'rad/second'
- 'rpm'
- 'kHz'
- 'MHz'
- 'GHz'
- 'rad/nanosecond'
- 'rad/microsecond'

- 'rad/millisecond'
- 'rad/minute'
- 'rad/hour'
- 'rad/day'
- 'rad/week'
- 'rad/month'
- 'rad/year'
- 'cycles/nanosecond'
- 'cycles/microsecond'
- 'cycles/millisecond'
- 'cycles/hour'
- 'cycles/day'
- 'cycles/week'
- 'cycles/month'
- 'cycles/year'

TimeUnits – Time units

'seconds' (default)

Time units, specified as one of the following values:

- 'nanoseconds'
- 'microseconds'
- 'milliseconds'
- 'seconds'
- 'minutes'
- 'hours'
- 'days'
- 'weeks'
- 'months'
- 'years'

You can also specify 'auto' which uses time units specified in the TimeUnit property of the input system. For multiple systems with different time units, the units of the first system is used.

ConfidenceRegionNumberSD – Number of standard deviations to use to plot the confidence region

1 (default) | scalar

Number of standard deviations to use to plot the confidence region, specified as a scalar. This is applicable to identified models only.

I0Grouping – Grouping of input-output pairs

'none' (default) | 'inputs' | 'outputs' | 'all'

Grouping of input-output (I/O) pairs, specified as one of the following:

- 'none' — No input-output grouping.
- 'inputs' — Group only the inputs.
- 'outputs' — Group only the outputs.
- 'all' — Group all the I/O pairs.

InputLabelStyle — Input label style

structure (default)

Input label style, specified as a structure with the following fields:

- **FontSize** — Font size, specified as a scalar value greater than zero in point units. The default font size depends on the specific operating system and locale. One point equals 1/72 inch.
- **FontWeight** — Character thickness, specified as 'Normal' or 'bold'. MATLAB uses the **FontWeight** property to select a font from those available on your system. Not all fonts have a bold weight. Therefore, specifying a bold font weight can still result in the normal font weight.
- **FontAngle** — Character slant, specified as 'Normal' or 'italic'. Not all fonts have both font styles. Therefore, the italic font might look the same as the normal font.
- **Color** — Text color, specified as an RGB triplet. The default color is dark grey with the RGB triplet [0.4,0.4,0.4].
- **Interpreter** — Text interpreter, specified as one of these values:
 - 'tex' — Interpret characters using a subset of TeX markup. This is the default value of **Interpreter**.
 - 'latex' — Interpret characters using LaTeX markup.
 - 'none' — Display literal characters.

OutputLabelStyle — Output label style

structure (default)

Output label style, specified as a structure with the following fields:

- **FontSize** — Font size, specified as a scalar value greater than zero in point units. The default font size depends on the specific operating system and locale. One point equals 1/72 inch.
- **FontWeight** — Character thickness, specified as 'Normal' or 'bold'. MATLAB uses the **FontWeight** property to select a font from those available on your system. Not all fonts have a bold weight. Therefore, specifying a bold font weight can still result in the normal font weight.
- **FontAngle** — Character slant, specified as 'Normal' or 'italic'. Not all fonts have both font styles. Therefore, the italic font might look the same as the normal font.
- **Color** — Text color, specified as an RGB triplet. The default color is dark grey with the RGB triplet [0.4,0.4,0.4].
- **Interpreter** — Text interpreter, specified as one of these values:
 - 'tex' — Interpret characters using a subset of TeX markup. This is the default value of **Interpreter**.
 - 'latex' — Interpret characters using LaTeX markup.
 - 'none' — Display literal characters.

InputVisible — Toggle display of inputs

'on' (default) | {'off'} | cell array

Toggle display of inputs, specified as either `{'on'}`, `{'off'}` or a cell array with multiple elements.

OutputVisible — Toggle display of outputs

`{'on'}` (default) | `{'off'}` | cell array

Toggle display of outputs, specified as either `{'on'}`, `{'off'}` or a cell array with multiple elements.

Title — Title text and style

structure (default)

Title text and style, specified as a structure with the following fields:

- **String** — Label text, specified as a character vector. By default, the plot is titled 'Pole-Zero Map'.
- **FontSize** — Font size, specified as a scalar value greater than zero in point units. The default font size depends on the specific operating system and locale. One point equals 1/72 inch.
- **FontWeight** — Character thickness, specified as 'Normal' or 'bold'. MATLAB uses the **FontWeight** property to select a font from those available on your system. Not all fonts have a bold weight. Therefore, specifying a bold font weight can still result in the normal font weight.
- **FontAngle** — Character slant, specified as 'Normal' or 'italic'. Not all fonts have both font styles. Therefore, the italic font might look the same as the normal font.
- **Color** — Text color, specified as an RGB triplet. The default color is black specified by the RGB triplet `[0,0,0]`.
- **Interpreter** — Text interpreter, specified as one of these values:
 - 'tex' — Interpret characters using a subset of TeX markup. This is the default value of **Interpreter**.
 - 'latex' — Interpret characters using LaTeX markup.
 - 'none' — Display literal characters.

XLabel — X-axis label text and style

structure (default)

X-axis label text and style, specified as a structure with the following fields:

- **String** — Label text, specified as a character vector. By default, the axis is titled based on the time units **TimeUnits**.
- **FontSize** — Font size, specified as a scalar value greater than zero in point units. The default font size depends on the specific operating system and locale. One point equals 1/72 inch.
- **FontWeight** — Character thickness, specified as 'Normal' or 'bold'. MATLAB uses the **FontWeight** property to select a font from those available on your system. Not all fonts have a bold weight. Therefore, specifying a bold font weight can still result in the normal font weight.
- **FontAngle** — Character slant, specified as 'Normal' or 'italic'. Not all fonts have both font styles. Therefore, the italic font might look the same as the normal font.
- **Color** — Text color, specified as an RGB triplet. The default color is black specified by the RGB triplet `[0,0,0]`.
- **Interpreter** — Text interpreter, specified as one of these values:
 - 'tex' — Interpret characters using a subset of TeX markup. This is the default value of **Interpreter**.

- 'latex' — Interpret characters using LaTeX markup.
- 'none' — Display literal characters.

YLabel — Y-axis label text and style

structure (default)

Y-axis label text and style, specified as a structure with the following fields:

- **String** — Label text, specified as a cell array of character vectors. By default, the axis is titled based on the time units `TimeUnits`.
- **FontSize** — Font size, specified as a scalar value greater than zero in point units. The default font size depends on the specific operating system and locale. One point equals 1/72 inch.
- **FontWeight** — Character thickness, specified as 'Normal' or 'bold'. MATLAB uses the `FontWeight` property to select a font from those available on your system. Not all fonts have a bold weight. Therefore, specifying a bold font weight can still result in the normal font weight.
- **FontAngle** — Character slant, specified as 'Normal' or 'italic'. Not all fonts have both font styles. Therefore, the italic font might look the same as the normal font.
- **Color** — Text color, specified as an RGB triplet. The default color is black specified by the RGB triplet `[0,0,0]`.
- **Interpreter** — Text interpreter, specified as one of these values:
 - 'tex' — Interpret characters using a subset of TeX markup. This is the default value of `Interpreter`.
 - 'latex' — Interpret characters using LaTeX markup.
 - 'none' — Display literal characters.

TickLabel — Tick label style

structure (default)

Tick label style, specified as a structure with the following fields:

- **FontSize** — Font size, specified as a scalar value greater than zero in point units. The default font size depends on the specific operating system and locale. One point equals 1/72 inch.
- **FontWeight** — Character thickness, specified as 'Normal' or 'bold'. MATLAB uses the `FontWeight` property to select a font from those available on your system. Not all fonts have a bold weight. Therefore, specifying a bold font weight can still result in the normal font weight.
- **FontAngle** — Character slant, specified as 'Normal' or 'italic'. Not all fonts have both font styles. Therefore, the italic font might look the same as the normal font.
- **Color** — Text color, specified as an RGB triplet. The default color is black specified by the RGB triplet `[0,0,0]`.

Grid — Toggle grid display

'off' (default) | 'on'

Toggle grid display on the plot, specified as either 'off' or 'on'.

GridColor — Color of the grid lines`[0.15,0.15,0.15]` (default) | RGB tripletColor of the grid lines, specified as an RGB triplet. The default color is light grey specified by the RGB triplet `[0.15,0.15,0.15]`.

XLimMode — X-axis limit selection mode

'auto' (default) | 'manual' | cell array

Selection mode for the x-axis limits, specified as one of these values:

- 'auto' — Enable automatic limit selection, which is based on the total span of the plotted data.
- 'manual' — Manually specify the axis limits. To specify the axis limits, set the XLim property.

YLimMode — Y-axis limit selection mode

'auto' (default) | 'manual' | cell array

Selection mode for the y-axis limits, specified as one of these values:

- 'auto' — Enable automatic limit selection, which is based on the total span of the plotted data.
- 'manual' — Manually specify the axis limits. To specify the axis limits, set the YLim property.

XLim — X-axis limits

'{[1,10]}' (default) | cell array of two-element vector of the form [min,max] | cell array

X-axis limits, specified as a cell array of two-element vector of the form [min,max].

YLim — Y-axis limits

'{[1,10]}' (default) | cell array of two-element vector of the form [min,max] | cell array

Y-axis limits, specified as a cell array of two-element vector of the form [min,max].

Object Functions

iopzplot Plot pole-zero map for I/O pairs with additional plot customization options

pzplot Pole-zero plot of dynamic system model with additional plot customization options

Examples**Pole-Zero Plot with Custom Options**

Plot the poles and zeros of the continuous-time system represented by the following transfer function with a custom option set:

$$\text{sys}(s) = \frac{2s^2 + 5s + 1}{s^2 + 3s + 5}.$$

Create the custom option set using pzoptions.

```
plotoptions = pzoptions;
```

For this example, specify the grid to be visible.

```
plotoptions.Grid = 'on';
```

Use the specified options to create a pole-zero map of the transfer function.

```
h = pzplot(tf([2 5 1],[1 3 5]),plotoptions);
```

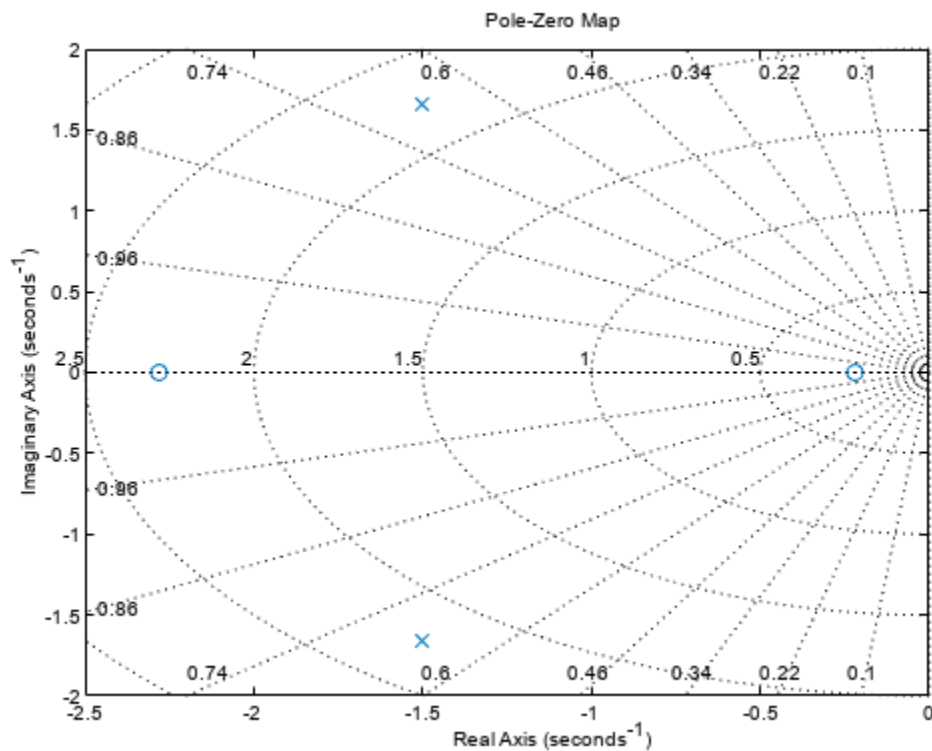

Turning on the grid displays lines of constant damping ratio (ζ) and lines of constant natural frequency (ω_n). This system has two real zeros, marked by o on the plot. The system also has a pair of complex poles, marked by x.

Version History

Introduced in R2008a

See Also

`getoptions` | `iopzplot` | `pzplot` | `setoptions`

Topics

“Toolbox Preferences Editor”

realp

Real tunable parameter

Syntax

```
p = realp(paramname,initvalue)
```

Description

`p = realp(paramname,initvalue)` creates a tunable real-valued parameter with name specified by `paramname` and initial value `initvalue`. Tunable real parameters can be scalar- or matrix-valued.

Input Arguments

paramname

Name of the `realp` parameter `p`, specified as a character vector such as `'a'` or `'zeta'`. This input argument sets the value of the `Name` property of `p`.

initvalue

Initial numeric value of the parameter `p`. `initvalue` can be a real scalar value or a 2-dimensional matrix.

Output Arguments

p

`realp` parameter object.

Properties

Name

Name of the `realp` parameter object, stored as a character vector. The value of `Name` is set by the `paramname` input argument to `realp` and cannot be changed.

Value

Value of the tunable parameter.

`Value` can be a real scalar value or a 2-dimensional matrix. The initial value is set by the `initvalue` input argument. The dimensions of `Value` are fixed on creation of the `realp` object.

Minimum

Lower bound for the parameter value. The dimension of the `Minimum` property matches the dimension of the `Value` property.

For matrix-valued parameters, use indexing to specify lower bounds on individual elements:

```
p = realp('K',eye(2));  
p.Minimum([1 4]) = -5;
```

Use scalar expansion to set the same lower bound for all matrix elements:

```
p.Minimum = -5;
```

Default: -Inf for all entries

Maximum

Upper bound for the parameter value. The dimension of the `Maximum` property matches the dimension of the `Value` property.

For matrix-valued parameters, use indexing to specify upper bounds on individual elements:

```
p = realp('K',eye(2));  
p.Maximum([1 4]) = 5;
```

Use scalar expansion to set the same upper bound for all matrix elements:

```
p.Maximum = 5;
```

Default: Inf for all entries

Free

Boolean value specifying whether the parameter is free to be tuned. Set the `Free` property to 1 (`true`) for tunable parameters, and 0 (`false`) for fixed parameters.

The dimension of the `Free` property matches the dimension of the `Value` property.

Default: 1 (`true`) for all entries

Examples

Tunable Low-Pass Filter

In this example, you will create a low-pass filter with one tunable parameter a :

$$F = \frac{a}{s + a}$$

Since the numerator and denominator coefficients of a `tunableTF` block are independent, you cannot use `tunableTF` to represent F . Instead, construct F using the tunable real parameter object `realp`.

Create a real tunable parameter with an initial value of 10.

```
a = realp('a',10)
```

```
a =  
    Name: 'a'  
    Value: 10  
    Minimum: -Inf
```

```
Maximum: Inf
Free: 1
```

Real scalar parameter.

Use `tf` to create the tunable low-pass filter `F`.

```
numerator = a;
denominator = [1,a];
F = tf(numerator,denominator)
```

`F =`

```
Generalized continuous-time state-space model with 1 outputs, 1 inputs, 1 states, and the following parameters:
a: Scalar parameter, 2 occurrences.
```

Type `"ss(F)"` to see the current value, `"get(F)"` to see all properties, and `"F.Blocks"` to interact with the blocks.

`F` is a `genss` object which has the tunable parameter `a` in its `Blocks` property. You can connect `F` with other tunable or numeric models to create more complex control system models. For an example, see “Control System with Tunable Components”.

Create Parametric Diagonal Matrix

Create a matrix with tunable diagonal elements and with off-diagonal elements fixed to zero.

Create a parametric matrix whose initial value is the identity matrix.

```
p = realp('P',eye(2));
```

`p` is a 2-by-2 parametric matrix. Since the initial value is the identity matrix, the off-diagonal initial values are zero.

Fix the values of the off-diagonal elements by setting the `Free` property to `false`.

```
p.Free(1,2) = false;
p.Free(2,1) = false;
```

Tips

- Use arithmetic operators (+, -, *, /, \, and ^) to combine `realp` objects into rational expressions or matrix expressions. You can use the resulting expressions in model-creation functions such as `tf`, `zpk`, and `ss` to create tunable models. For more information about tunable models, see “Models with Tunable Coefficients” in the *Control System Toolbox User's Guide*.

Version History

Introduced in R2011a

See Also

`genss` | `genmat` | `tf` | `ss`

Topics

“Models with Tunable Coefficients”

Reduce Model Order

Reduce complexity of linear time-invariant (LTI) models in the Live Editor

Description

The **Reduce Model Order** task lets you interactively compute reduced-order approximations of high-order models while preserving model characteristics that are important to your application. The task automatically generates MATLAB code for your live script. For more information about Live Editor tasks generally, see “Add Interactive Tasks to a Live Script”.

Working with lower order models can simplify analysis and control design. Simpler models are also easier to understand and manipulate. You can reduce a plant model to focus on relevant dynamics before designing a controller for the plant. You can also use model reduction to simplify a full-order controller. For more information about model reduction and when it is useful, see “Model Reduction Basics”.

To get started, select a model to reduce and a model-reduction method. For each method, the task gives you controls and plots that help you ensure that your reduced model preserves dynamics that are important for your application.

- **Balanced Truncation** — Compute a lower order approximation of your model by removing states with relatively small energy contributions.
- **Mode Selection** — Select modes by specifying a frequency range of interest.
- **Pole-Zero Simplification** — Eliminate canceling or near-canceling pole-zero pairs.

Related Functions

The model-reduction code that **Reduce Model Order** generates uses the following functions.

- `balred`
- `freqsep`
- `minreal`

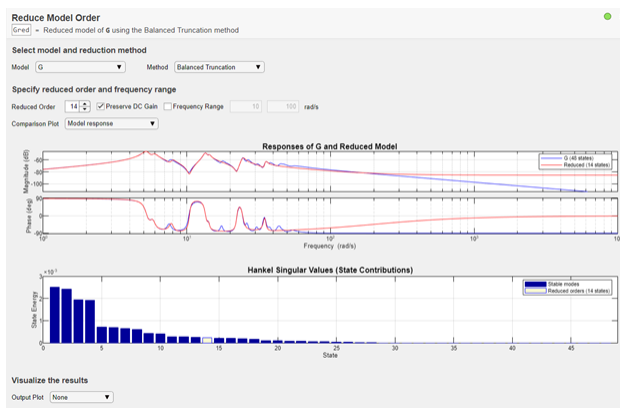

Description (collapsed portion)

Related Functions

The model-reduction code that **Reduce Model Order** generates uses the following functions.

- `balred`
- `freqsep`
- `minreal`

Open the Task

To add the **Reduce Model Order** task to a live script in the MATLAB Editor:

- On the **Live Editor** tab, select **Task > Reduce Model Order**.
- In a code block in your script, type a relevant keyword, such as `reduce`, `balred`, or `minreal`. Select **Reduce Model Order** from the suggested command completions.

Parameters

Model — Model to reduce

numeric LTI model

Choose the model to reduce. The list of available models includes proper `tf`, `ss`, or `zpk` models in the MATLAB workspace. The model can be SISO or MIMO, and continuous or discrete.

- Continuous-time models cannot have time delays. To reduce a continuous-time model with time delays, first use `pade` to approximate the time delays as model dynamics.
- Discrete-time models can have time delays. For the **Balanced Truncation** reduction method, the task uses `absorbDelay` to convert the delay into poles at $z = 0$ before reducing the model.

Note **Reduce Model Order** assumes that the model time unit (specified in the `TimeUnit` property of the model) is seconds. For the **Balanced Truncation** and **Mode Selection** methods, if your model does not have `TimeUnit = 'seconds'`, use `chgTimeUnit` to convert the model to seconds.

Method — Model reduction method

Balanced Truncation (default) | **Mode Selection** | **Pole-Zero Simplification**

For each method, the **Reduce Model Order** task gives you controls and plots that help you ensure that your reduced model preserves dynamics that are important for your application.

- **Balanced Truncation** — Compute a lower order approximation of your model by removing states with relatively small energy contributions. To use this method, specify the number of states (order) in the reduced model. The Hankel singular-value plot visualizes the relative energy contribution of each state in the original model. The task discards states with lower energy than the state you select in this plot. This method generates code that uses the `balred` command.

For discrete-time model that has time delays, **Reduce Model Order** uses `absorbDelay` to convert the delay into poles at $z = 0$ before reducing the model by balanced truncation. The additional states are reflected in the response plot and Hankel singular-value plot.

- **Mode Selection** — Select modes by specifying a frequency range of interest. The task discards dynamics that fall outside the region you specify on the frequency-response plot. This method generates code that uses the `freqsep` command.
- **Pole-Zero Simplification** — Eliminate canceling or near-canceling pole-zero pairs. The task discards pole-zero pairs that cancel with the threshold specified by the **Tolerance** parameter. Increase the tolerance to discard more states. This method generates code that uses the `minreal` command.

Balanced Truncation Parameters

Reduced Order — Number of states in reduced model

positive integer

Specify the number of states in the reduced-order model. You can use any value that falls between the number of unstable states in the model and the number of states in the original model. For more information, see “Balanced Truncation Model Reduction”.

Preserve DC Gain — Match DC gain of reduced model to that of original model

on (default) | off

Match the DC gain of the reduced model to that of the original model. Select **Preserve DC Gain** when the DC behavior of the model is important in your application. Clear the parameter to get better matching of higher frequency behavior. For more information, see “Balanced Truncation Model Reduction”.

Frequency Range — Limit analysis to specified frequencies

off (default) | on

By default, **Reduce Model Order** analyzes Hankel singular values across all frequencies. Restricting this analysis to a particular frequency range is useful when you know the model has modes outside the region of interest to your particular application. When you apply a frequency limit, **Reduce Model Order** determines which states are the low-energy states to truncate based on their energy contribution within the specified frequency range only.

To limit the analysis of state contributions to a particular frequency range, check **Frequency range**. Then, drag the vertical cursors on the response plot to specify the frequency range of interest. Alternatively, enter the minimum and maximum frequencies in the text boxes. The unit is rad/s. If your model does not have `TimeUnit = 'seconds'`, use `chgTimeUnit` to convert the model to seconds.

Comparison Plot — How to compare original and reduced models

Model response (default) | Absolute error | Relative error

Reduce Model Order shows you a comparison of the frequency responses between the original and reduced models. You can use this plot to monitor the match between the original and reduced-order models while you experiment with model-reduction parameter values. Available comparison plots are:

- **Model response** — Frequency response of the original and reduced models, shown as a Bode plot for SISO models and a singular-value plot for MIMO models.
- **Absolute error plot** — Singular values of $G - G_r$, where G is the original model and G_r is the current reduced model. (For SISO models, the singular-value plot is the magnitude of the frequency response.)

- **Relative error plot** — Singular values of $(G - G_r)/G$. This plot is useful when the model has very high or very low gain in the region that is important to your application. In such regions, absolute error can be misleading.

Mode Selection Parameters

Cutoff Frequency — Frequency range in which to preserve dynamics

positive scalar values

Specify the lower and upper bounds of the frequency range in which to preserve dynamics. You can also use the vertical cursors on the response plot to specify the range. **Reduce Model Order** discards dynamics outside the specified range.

For more information about this method, see “Mode-Selection Model Reduction”.

Comparison Plot — How to compare original and reduced models

Model response (default) | Absolute error | Relative error

Reduce Model Order shows you a comparison of the frequency responses between the original and reduced models. You can use this plot to monitor the match between the original and reduced-order models while you experiment with model-reduction parameter values. Available comparison plots are:

- **Model response** — Frequency response of the original and reduced models, shown as a Bode plot for SISO models and a singular-value plot for MIMO models.
- **Absolute error plot** — Singular values of $G - G_r$, where G is the original model and G_r is the current reduced model. (For SISO models, the singular-value plot is the magnitude of the frequency response.)
- **Relative error plot** — Singular values of $(G - G_r)/G$. This plot is useful when the model has very high or very low gain in the region that is important to your application. In such regions, absolute error can be misleading.

Pole-Zero Simplification Parameters

Tolerance — Margin for pole-zero cancellation

positive scalar

Specify the margin for pole-zero cancellation. Pole-zero pairs that cancel within this tolerance are removed from the reduced model. You can use the slider to change the tolerance and observe the results in a response plot.

Results Parameters

Output Plot — Type of response plot to generate

None (default) | Step | Impulse | Bode | ...

Reduce Model Order generates code that shows the response of the original and reduced systems on the plot type you specify. Available plots include:

- Step response
- Impulse response
- Bode plot
- Singular value (sigma) plot
- Pole-zero plot

Version History

Introduced in R2019b

See Also

Functions

balred | minreal | freqsep

Apps

Model Reducer

Topics

“Model Reduction in the Live Editor”

“Model Reduction Basics”

reg

Form regulator given state-feedback and estimator gains

Syntax

```
rsys = reg(sys,K,L)
rsys = reg(sys,K,L,sensors,known,controls)
```

Description

`rsys = reg(sys,K,L)` forms a dynamic regulator or compensator `rsys` given a state-space model `sys` of the plant, a state-feedback gain matrix `K`, and an estimator gain matrix `L`. The gains `K` and `L` are typically designed using pole placement or LQG techniques. The function `reg` handles both continuous- and discrete-time cases.

This syntax assumes that all inputs of `sys` are controls, and all outputs are measured. The regulator `rsys` is obtained by connecting the state-feedback law $u = -Kx$ and the state estimator with gain matrix `L` (see `estim`). For a plant with equations

$$\begin{aligned}\dot{x} &= Ax + Bu \\ y &= Cx + Du\end{aligned}$$

this yields the regulator

$$\begin{aligned}\dot{\hat{x}} &= [A - LC - (B - LD)K]\hat{x} + Ly \\ u &= -K\hat{x}\end{aligned}$$

This regulator should be connected to the plant using *positive* feedback.

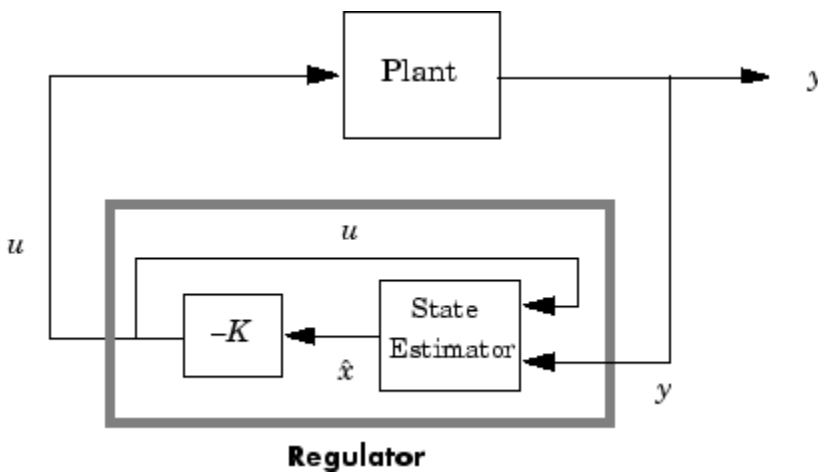

`rsys = reg(sys,K,L,sensors,known,controls)` handles more general regulation problems where:

- The plant inputs consist of controls u , known inputs u_d , and stochastic inputs w .

- Only a subset y of the plant outputs is measured.

The index vectors `sensors`, `known`, and `controls` specify y , u_d , and u as subsets of the outputs and inputs of `sys`. The resulting regulator uses $[u_d; y]$ as inputs to generate the commands u (see next figure).

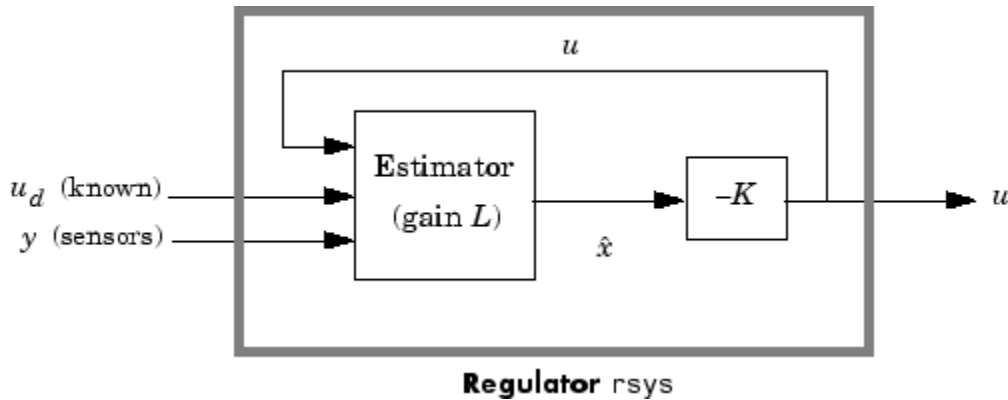

Examples

Given a continuous-time state-space model

```
sys = ss(A,B,C,D)
```

with seven outputs and four inputs, suppose you have designed:

- A state-feedback controller gain K using inputs 1, 2, and 4 of the plant as control inputs
- A state estimator with gain L using outputs 4, 7, and 1 of the plant as sensors, and input 3 of the plant as an additional known input

You can then connect the controller and estimator and form the complete regulation system by

```
controls = [1,2,4];
sensors = [4,7,1];
known = [3];
regulator = reg(sys,K,L,sensors,known,controls)
```

Version History

Introduced before R2006a

See Also

`estim` | `kalman` | `lqgreg` | `lqr` | `dlqr` | `place`

replaceBlock

Replace or update control design blocks in generalized LTI model

Syntax

```
Mnew = replaceBlock(M,Block1,Value1,...,BlockN,ValueN)
Mnew = replaceBlock(M,blockvalues)
Mnew = replaceBlock(...,mode)
```

Description

`Mnew = replaceBlock(M,Block1,Value1,...,BlockN,ValueN)` replaces the Control Design Blocks `Block1,...,BlockN` of `M` with the specified values `Value1,...,ValueN`. `M` is a Generalized LTI model or a Generalized matrix.

`Mnew = replaceBlock(M,blockvalues)` specifies the block names and replacement values as field names and values of the structure `blockvalues`.

`Mnew = replaceBlock(...,mode)` performs block replacement on an array of models `M` using the substitution mode specified by `mode`.

Input Arguments

M

Generalized LTI model, Generalized matrix, or array of such models.

Block1,...,BlockN

Names of Control Design Blocks in `M`. The `replaceBlock` command replaces each listed block of `M` with the corresponding values `Value1,...,ValueN` that you supply.

If a specified `Block` is not a block of `M`, `replaceBlock` that block and the corresponding value.

Value1,...,ValueN

Replacement values for the corresponding blocks `Block1,...,BlockN`.

The replacement value for a block can be any value compatible with the size of the block, including a different Control Design Block, a numeric matrix, or an LTI model. If any value is `[]`, the corresponding block is replaced by its nominal (current) value.

blockvalues

Structure specifying blocks of `M` to replace and the values with which to replace those blocks.

The field names of `blockvalues` match names of Control Design Blocks of `M`. Use the field values to specify the replacement values for the corresponding blocks of `M`. The replacement values may be numeric values, Numeric LTI models, Control Design Blocks, or Generalized LTI models.

mode

Block replacement mode for an input array M of Generalized matrices or LTI models, specified as one of the following values:

- `'-once'` (default) — Vectorized block replacement across the model array M . Each block is replaced by a single value, but the value may change from model to model across the array.

For vectorized block replacement, use a structure array for the input `blockvalues`, or cell arrays for the `Value1, ..., ValueN` inputs. For example, if M is a 2-by-3 array of models:

- $M_{\text{new}} = \text{replaceBlock}(M, \text{blockvalues}, \text{'-once'})$, where `blockvalues` is a 2-by-3 structure array, specifies one set of block values `blockvalues(k)` for each model $M(:, :, k)$ in the array.
- $M_{\text{new}} = \text{replaceBlock}(M, \text{Block}, \text{Value}, \text{'-once'})$, where `Value` is a 2-by-3 cell array, replaces `Block` by `Value{k}` in the model $M(:, :, k)$ in the array.
- `'-batch'` — Batch block replacement. Each block is replaced by an array of values, and the same array of values is used for each model in M . The resulting array of model M_{new} is of size $[\text{size}(M) \text{ Asize}]$, where `Asize` is the size of the replacement value.

When the input M is a single model, `'-once'` and `'-batch'` return identical results.

Default: `'-once'`

Output Arguments

M_{new}

Matrix or linear model or matrix where the specified blocks are replaced by the specified replacement values.

M_{new} is a numeric array or numeric LTI model when all the specified replacement values are numeric values or numeric LTI models.

Examples

Replace Control Design Block with Numeric Values

This example shows how to replace a tunable PID controller (`tunablePID`) in a Generalized LTI model by a pure gain, a numeric PI controller, or the current value of the tunable controller.

- 1 Create a Generalized LTI model of the following system:

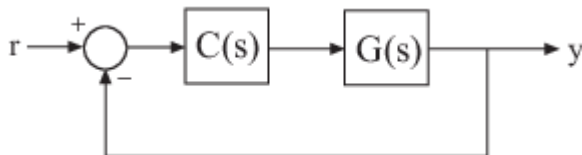

where the plant $G(s) = \frac{(s-1)}{(s+1)^3}$, and C is a tunable PID controller.

```
G = zpk(1, [-1, -1, -1], 1);
C = tunablePID('C', 'pid');
Try = feedback(G*C, 1)
```

- 2 Replace C by a pure gain of 5.

```
T1 = replaceBlock(Try, 'C', 5);
```

T1 is a ss model that equals `feedback(G*5, 1)`.

- 3 Replace C by a PI controller with proportional gain of 5 and integral gain of 0.1.

```
C2 = pid(5, 0.1);
T2 = replaceBlock(Try, 'C', C2);
```

T2 is a ss model that equals `feedback(G*C2, 1)`.

- 4 Replace C by its current (nominal) value.

```
T3 = replaceBlock(Try, 'C', []);
```

T3 is a ss model where C has been replaced by `getValue(C)`.

Sample Tunable Model Over Grid of Values

Consider the second-order filter represented by:

$$F(s) = \frac{\omega_n^2}{s^2 + 2\zeta\omega_n s + \omega_n^2}$$

Sample this filter at varying values of the damping constant ζ and the natural frequency ω_n . Create a tunable model of the filter by using tunable elements for ζ and ω_n .

```
wn = realp('wn', 3);
zeta = realp('zeta', 0.8);
F = tf(wn^2, [1 2*zeta*wn wn^2])
```

F =

```
Generalized continuous-time state-space model with 1 outputs, 1 inputs, 2 states, and the following parameters:
  wn: Scalar parameter, 5 occurrences.
  zeta: Scalar parameter, 1 occurrences.
```

Type `"ss(F)"` to see the current value, `"get(F)"` to see all properties, and `"F.Blocks"` to interact with the blocks.

Create a grid of sample values.

```
wnvals = [3; 5];
zetavals = [0.6 0.8 1.0];
[wngrid, zetagrid] = ndgrid(wnvals, zetavals);
Fsample = replaceBlock(F, 'wn', wngrid, 'zeta', zetagrid);
size(Fsample)
```

```
2x3 array of state-space models.
Each model has 1 outputs, 1 inputs, and 2 states.
```

The `ndgrid` command produces a full 2-by-3 grid of parameter combinations. Thus, `Fsample` is a 2-by-3 array of state-space models. Each entry in the array is a state-space model that represents F

evaluated at the corresponding (wn, zeta) pair. For example, `Fsample(:, :, 2, 3)` has $\text{wn} = 5$ and $\text{zeta} = 1.0$.

```
damp(Fsample(:, :, 2, 3))
```

Pole	Damping	Frequency (rad/seconds)	Time Constant (seconds)
-5.00e+00	1.00e+00	5.00e+00	2.00e-01
-5.00e+00	1.00e+00	5.00e+00	2.00e-01

Tips

- Use `replaceBlock` to perform parameter studies by sampling Generalized LTI models across a grid of parameters, or to evaluate tunable models for specific values of the tunable blocks. See “Examples” on page 2-1071.
- For additional options for sampling control design blocks, including concurrent sampling, use `sampleBlock`.
- To take random samples of control design blocks, see `rsampleBlock`

Version History

Introduced in R2011a

See Also

`getValue` | `genss` | `genmat` | `nblocks` | `sampleBlock` | `rsampleBlock`

Topics

“Generalized Matrices”

“Generalized and Uncertain LTI Models”

“Models with Tunable Coefficients”

repsys

Replicate and tile models

Syntax

```
rsys = repsys(sys, [M N])  
rsys = repsys(sys, N)  
rsys = repsys(sys, [M N S1, ..., Sk])
```

Description

`rsys = repsys(sys, [M N])` replicates the model `sys` into an M-by-N tiling pattern. The resulting model `rsys` has `size(sys,1)*M` outputs and `size(sys,2)*N` inputs.

`rsys = repsys(sys, N)` creates an N-by-N tiling.

`rsys = repsys(sys, [M N S1, ..., Sk])` replicates and tiles `sys` along both I/O and array dimensions to produce a model array. The indices `S` specify the array dimensions. The size of the array is `[size(sys,1)*M, size(sys,2)*N, size(sys,3)*S1, ...]`.

Input Arguments

sys

Model to replicate.

M

Number of replications of `sys` along the output dimension.

N

Number of replications of `sys` along the input dimension.

S

Numbers of replications of `sys` along array dimensions.

Output Arguments

rsys

Model having `size(sys,1)*M` outputs and `size(sys,2)*N` inputs.

If you provide array dimensions `S1, ..., Sk`, `rsys` is an array of dynamic systems which each have `size(sys,1)*M` outputs and `size(sys,2)*N` inputs. The size of `rsys` is `[size(sys,1)*M, size(sys,2)*N, size(sys,3)*S1, ...]`.

Examples

Replicate SISO Transfer Function to Create MIMO Transfer Function

Create a single-input single-output (SISO) transfer function.

```
sys = tf(2,[1 3])
```

```
sys =
```

$$\frac{2}{s + 3}$$

Continuous-time transfer function.

Replicate the SISO transfer function to create a MIMO transfer function that has three inputs and two outputs.

```
rsys = repsys(sys,[2 3])
```

```
rsys =
```

```
From input 1 to output...
```

$$1: \frac{2}{s + 3}$$

$$2: \frac{2}{s + 3}$$

```
From input 2 to output...
```

$$1: \frac{2}{s + 3}$$

$$2: \frac{2}{s + 3}$$

```
From input 3 to output...
```

$$1: \frac{2}{s + 3}$$

$$2: \frac{2}{s + 3}$$

Continuous-time transfer function.

Alternatively, you can obtain the MIMO transfer function as follows:

```
rsys = [sys sys sys; sys sys sys];
```

Replicate SISO Transfer Function to Create Array of Transfer Functions

Create a SISO transfer function.

```
sys = tf(2,[1 3]);
```

Replicate the transfer function into a 3-by-4 array of two-input, one-output transfer functions.

```
rsys = repsys(sys,[1 2 3 4]);
```

Check the size of `rsys`.

```
size(rsys)
```

```
3x4 array of transfer functions.  
Each model has 1 outputs and 2 inputs.
```

Tips

`rsys = repsys(sys,N)` produces the same result as `rsys = repsys(sys,[N N])`. To produce a diagonal tiling, use `rsys = sys*eye(N)`.

Version History

Introduced in R2010b

See Also

`append`

reshape

Change shape of model array

Syntax

```
sys = reshape(sys,s1,s2,...,sk)
sys = reshape(sys,[s1 s2 ... sk])
```

Description

`sys = reshape(sys,s1,s2,...,sk)` (or, equivalently, `sys = reshape(sys,[s1 s2 ... sk])`) reshapes the LTI array `sys` into an `s1`-by-`s2`-by-...-by-`sk` model array. With either syntax, there must be `s1*s2*...*sk` models in `sys` to begin with.

Examples

Change Shape of Model Array

Generate a 2-by-3 array of SISO models with four states each.

```
sys = rss(4,1,1,2,3);
size(sys)
```

2x3 array of state-space models.
Each model has 1 outputs, 1 inputs, and 4 states.

Change the shape of the array to create a 6-by-1 model array.

```
sys1 = reshape(sys,6,1);
size(sys1)
```

6x1 array of state-space models.
Each model has 1 outputs, 1 inputs, and 4 states.

Version History

Introduced before R2006a

See Also

`ndims` | `size`

residual

Return measurement residual and residual covariance when using extended or unscented Kalman filter

Syntax

```
[Residual,ResidualCovariance] = residual(obj,y)
[Residual,ResidualCovariance] = residual(obj,y,Um1,...,Umn)
```

Description

The `residual` command returns the difference between the actual and predicted measurements for `extendedKalmanFilter` and `unscentedKalmanFilter` objects. Viewing the residual provides a way for you to validate the performance of the filter. Residuals, also known as innovations, quantify the prediction error and drive the correction step in the extended and unscented Kalman filter update sequence. When using `correct` and `predict` to update the estimated Kalman filter state, use the `residual` command immediately before using the `correct` command.

`[Residual,ResidualCovariance] = residual(obj,y)` returns the residual `Residual` between a measurement `y` and a predicted measurement produced by the Kalman filter `obj`. The function also returns the covariance of the residual `ResidualCovariance`.

You create `obj` using the `extendedKalmanFilter` or `unscentedKalmanFilter` commands. You specify the state transition function f and measurement function h of your nonlinear system in `obj`. The `State` property of the object stores the latest estimated state value. At each time step, you use `correct` and `predict` together to update the state x . The residual s is the difference between the actual and predicted measurements for the time step, and is expressed as $s = y - h(x)$. The covariance of the residual S is the sum $R + R_p$, where R is the measurement noise matrix set by the `MeasurementNoise` property of the filter and R_p is the state covariance matrix projected onto the measurement space.

Use this syntax if the measurement function h that you specified in `obj.MeasurementFcn` has one of the following forms:

- $y(k) = h(x(k))$ for additive measurement noise
- $y(k) = h(x(k),v(k))$ for nonadditive measurement noise

Here, $y(k)$, $x(k)$, and $v(k)$ are the measured output, states, and measurement noise of the system at time step k . The only inputs to h are the states and measurement noise.

`[Residual,ResidualCovariance] = residual(obj,y,Um1,...,Umn)` specifies additional input arguments if the measurement function of the system requires these inputs. You can specify multiple arguments.

Use this syntax if the measurement function h has one of the following forms:

- $y(k) = h(x(k),Um1,...,Umn)$ for additive measurement noise
- $y(k) = h(x(k),v(k),Um1,...,Umn)$ for nonadditive measurement noise

Examples

Estimate States Online Using Extended Kalman Filter

Estimate the states of a van der Pol oscillator using an extended Kalman filter algorithm and measured output data. The oscillator has two states and one output.

Create an extended Kalman filter object for the oscillator. Use previously written and saved state transition and measurement functions, `vdpStateFcn.m` and `vdpMeasurementFcn.m`. These functions describe a discrete-approximation to a van der Pol oscillator with the nonlinearity parameter μ equal to 1. The functions assume additive process and measurement noise in the system. Specify the initial state values for the two states as `[1;0]`. This is the guess for the state value at initial time k , based on knowledge of system outputs until time $k-1$, $\hat{x}[k|k-1]$.

```
obj = extendedKalmanFilter(@vdpStateFcn,@vdpMeasurementFcn,[1;0]);
```

Load the measured output data `y` from the oscillator. In this example, use simulated static data for illustration. The data is stored in the `vdp_data.mat` file.

```
load vdp_data.mat y
```

Specify the process noise and measurement noise covariances of the oscillator.

```
obj.ProcessNoise = 0.01;
obj.MeasurementNoise = 0.16;
```

Initialize arrays to capture results of the estimation.

```
residBuf = [];
xcorBuf = [];
xpredBuf = [];
```

Implement the extended Kalman filter algorithm to estimate the states of the oscillator by using the `correct` and `predict` commands. You first correct $\hat{x}[k|k-1]$ using measurements at time k to get $\hat{x}[k|k]$. Then, you predict the state value at the next time step $\hat{x}[k+1|k]$ using $\hat{x}[k|k]$, the state estimate at time step k that is estimated using measurements until time k .

To simulate real-time data measurements, use the measured data one time step at a time. Compute the residual between the predicted and actual measurement to assess how well the filter is performing and converging. Computing the residual is an optional step. When you use `residual`, place the command immediately before the `correct` command. If the prediction matches the measurement, the residual is zero.

After you perform the real-time commands for the time step, buffer the results so that you can plot them after the run is complete.

```
for k = 1:size(y)
    [Residual,ResidualCovariance] = residual(obj,y(k));
    [CorrectedState,CorrectedStateCovariance] = correct(obj,y(k));
    [PredictedState,PredictedStateCovariance] = predict(obj);

    residBuf(k,:) = Residual;
    xcorBuf(k,:) = CorrectedState';
    xpredBuf(k,:) = PredictedState';
end
```

When you use the `correct` command, `obj.State` and `obj.StateCovariance` are updated with the corrected state and state estimation error covariance values for time step k , `CorrectedState` and `CorrectedStateCovariance`. When you use the `predict` command, `obj.State` and `obj.StateCovariance` are updated with the predicted values for time step $k+1$, `PredictedState` and `PredictedStateCovariance`. When you use the `residual` command, you do not modify any `obj` properties.

In this example, you used `correct` before `predict` because the initial state value was $\hat{x}[k|k-1]$, a guess for the state value at initial time k based on system outputs until time $k-1$. If your initial state value is $\hat{x}[k-1|k-1]$, the value at previous time $k-1$ based on measurements until $k-1$, then use the `predict` command first. For more information about the order of using `predict` and `correct`, see “Using `predict` and `correct` Commands” on page 2-179.

Plot the estimated states, using the postcorrection values.

```
plot(xcorBuf(:,1), xcorBuf(:,2))
title('Estimated States')
```

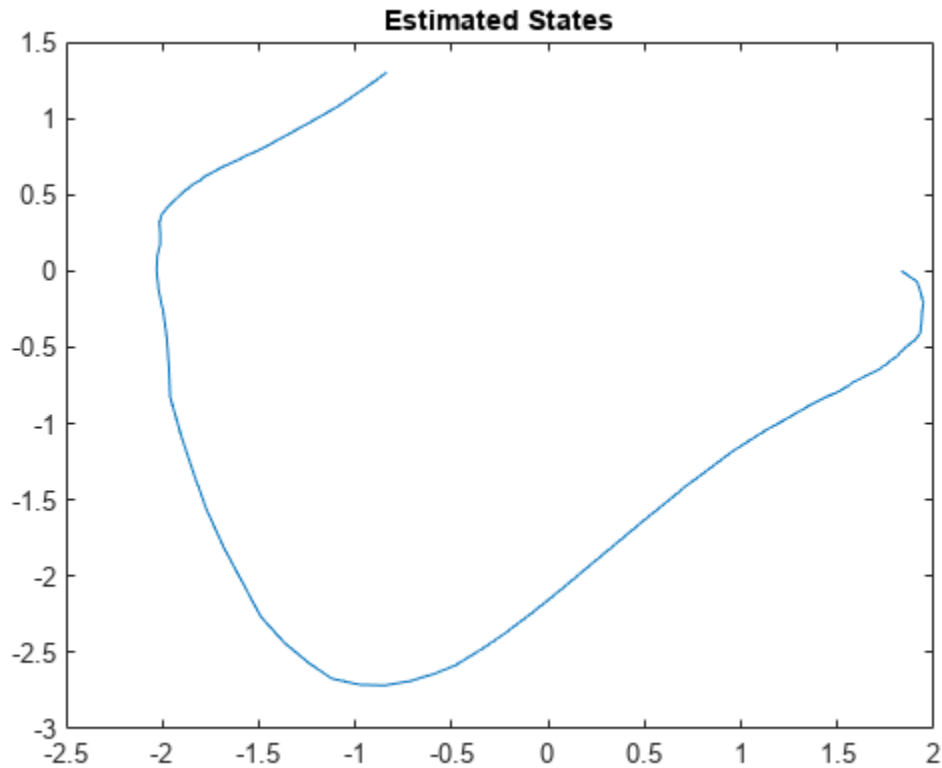

Plot the actual measurement, the corrected estimated measurement, and the residual. For the measurement function in `vdpMeasurementFcn`, the measurement is the first state.

```
M = [y,xcorBuf(:,1),residBuf];
plot(M)
grid on
title('Actual and Estimated Measurements, Residual')
legend('Measured','Estimated','Residual')
```

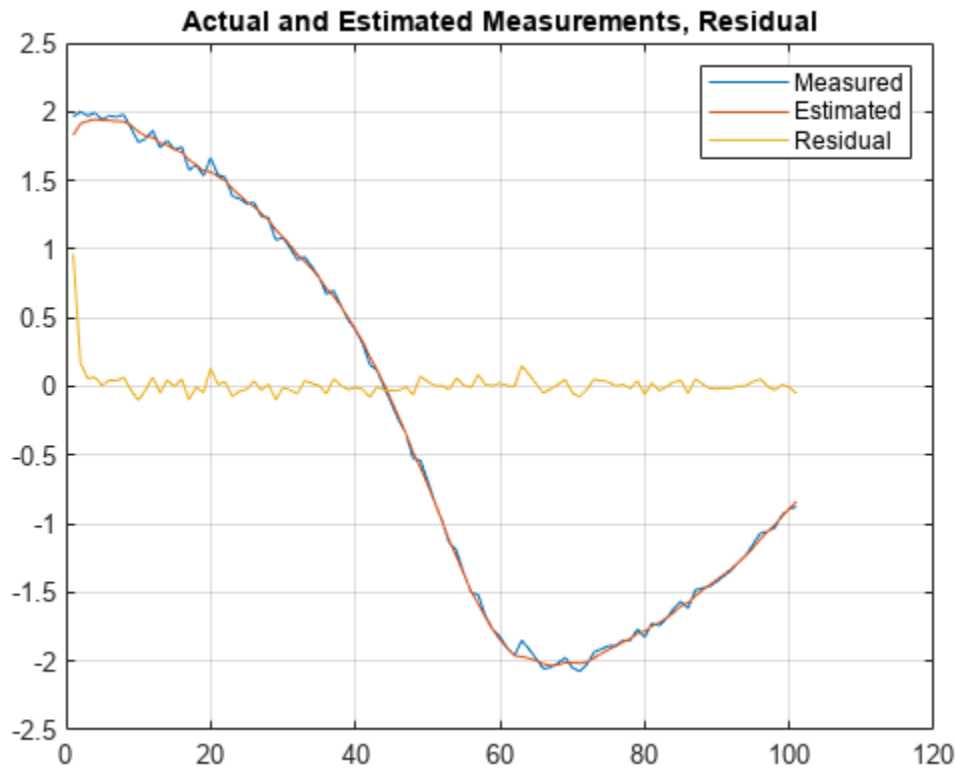

The estimate tracks the measurement closely. After the initial transient, the residual remains relatively small throughout the run.

Specify State Transition and Measurement Functions with Additional Inputs

Consider a nonlinear system with input u whose state x and measurement y evolve according to the following state transition and measurement equations:

$$x[k] = \sqrt{x[k-1] + u[k-1]} + w[k-1]$$

$$y[k] = x[k] + 2 * u[k] + v[k]^2$$

The process noise w of the system is additive while the measurement noise v is nonadditive.

Create the state transition function and measurement function for the system. Specify the functions with an additional input u .

```
f = @(x,u)(sqrt(x+u));
h = @(x,v,u)(x+2*u+v^2);
```

f and h are function handles to the anonymous functions that store the state transition and measurement functions, respectively. In the measurement function, because the measurement noise is nonadditive, v is also specified as an input. Note that v is specified as an input before the additional input u .

Create an extended Kalman filter object for estimating the state of the nonlinear system using the specified functions. Specify the initial value of the state as 1 and the measurement noise as nonadditive.

```
obj = extendedKalmanFilter(f,h,1,'HasAdditiveMeasurementNoise',false);
```

Specify the measurement noise covariance.

```
obj.MeasurementNoise = 0.01;
```

You can now estimate the state of the system using the `predict` and `correct` commands. You pass the values of `u` to `predict` and `correct`, which in turn pass them to the state transition and measurement functions, respectively.

Correct the state estimate with measurement $y[k]=0.8$ and input $u[k]=0.2$ at time step k .

```
correct(obj,0.8,0.2)
```

Predict the state at the next time step, given $u[k]=0.2$.

```
predict(obj,0.2)
```

Retrieve the error, or *residual*, between the prediction and the measurement.

```
[Residual, ResidualCovariance] = residual(obj,0.8,0.2);
```

Input Arguments

obj — Extended or unscented Kalman filter

extendedKalmanFilter object | unscentedKalmanFilter object

Extended or unscented Kalman filter, created using one of the following commands:

- `extendedKalmanFilter` — Uses the extended Kalman filter algorithm
- `unscentedKalmanFilter` — Uses the unscented Kalman filter algorithm

y — Measured system output

vector

Measured system output at the current time step, specified as an N -element vector, where N is the number of measurements.

Um1, ..., Umn — Additional input arguments to measurement function

input arguments of any type

Additional input arguments to the measurement function of the system, specified as input arguments of any type. The measurement function h is specified in the `MeasurementFcn` or `MeasurementLikelihoodFcn` property of `obj`. If the function requires input arguments in addition to the state and measurement noise values, you specify these inputs in the `residual` command syntax. The `residual` command passes these inputs to the measurement or the measurement likelihood function to calculate estimated outputs. You can specify multiple arguments.

For instance, suppose that your measurement or measurement likelihood function calculates the estimated system output y using system inputs u and current time k , in addition to the state x . The U_{m1} and U_{m2} terms are therefore $u(k)$ and k . These inputs result in the estimated output

$$y(k) = h(x(k), u(k), k)$$

Before you perform online state estimation correction at time step k , specify these additional inputs in the `residual` command syntax:

```
[Residual,ResidualCovariance] = residual(obj,y,u(k),k);
```

For an example showing how to use additional input arguments, see “Specify State Transition and Measurement Functions with Additional Inputs” on page 2-1081.

Output Arguments

Residual — Residual between current and predicted measurement

scalar | vector

Residual between current and predicted measurement, returned as a:

- Scalar for a single-output system
- Vector of size N for a multiple-output system, where N is the number of measured outputs

ResidualCovariance — Residual covariance

matrix

Residual covariance, returned as an N -by- N matrix where N is the number of measured outputs.

Version History

Introduced in R2019b

See Also

`correct` | `predict` | `extendedKalmanFilter` | `unscentedKalmanFilter`

Topics

“Nonlinear State Estimation Using Unscented Kalman Filter and Particle Filter”

“Generate Code for Online State Estimation in MATLAB”

“Extended and Unscented Kalman Filter Algorithms for Online State Estimation”

“Validate Online State Estimation at the Command Line”

rlocus

Root locus plot of dynamic system

Syntax

```
rlocus(sys)
rlocus(sys1,sys2,...)
```

```
[r,k] = rlocus(sys)
r = rlocus(sys,k)
```

Description

`rlocus(sys)` calculates and plots the root locus of the SISO model `sys`. The root locus returns the closed-loop pole trajectories as a function of the feedback gain `k` (assuming negative feedback). Root loci are used to study the effects of varying feedback gains on closed-loop pole locations. In turn, these locations provide indirect information on the time and frequency responses.

You can use `rlocus` to plot the root locus diagram of any of the following *negative* feedback loops by setting `sys` as shown below:

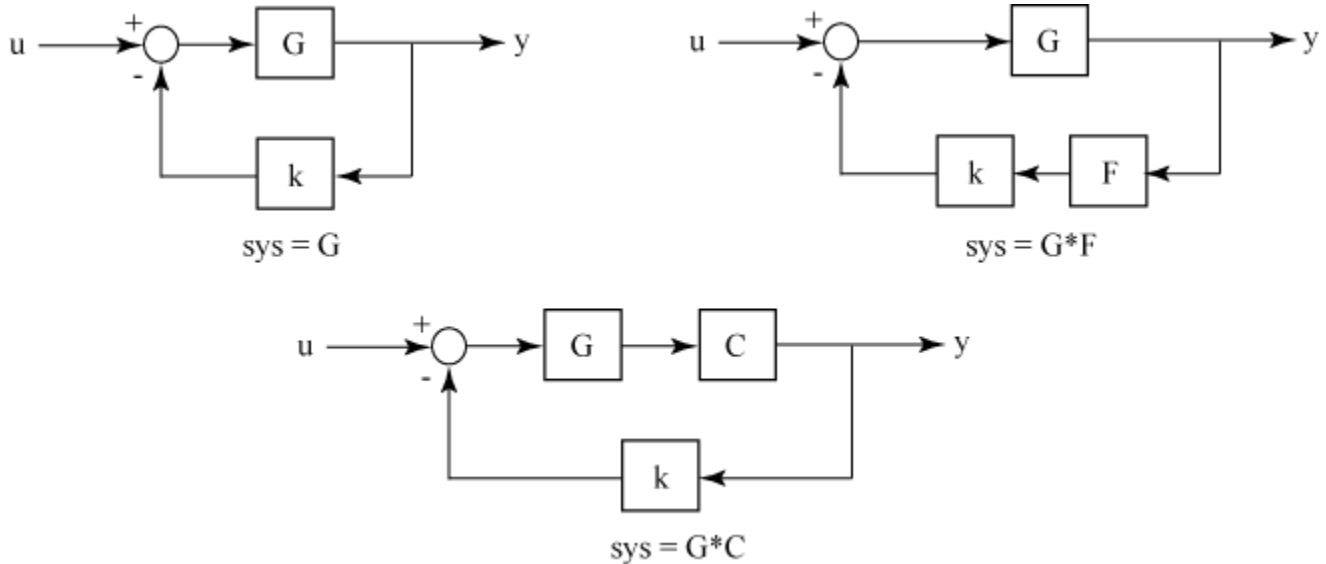

For instance, if `sys` is a transfer function represented by

$$sys(s) = \frac{n(s)}{d(s)}$$

the closed-loop poles are the roots of

$$d(s) + kn(s) = 0$$

The root locus plot depicts the trajectories of closed-loop poles when the feedback-gain k varies from 0 to infinity. `rlocus` adaptively selects a set of positive gains k to produce a smooth plot. The poles on the root locus plot are denoted by \times and the zeros are denoted by \circ .

`rlocus(sys1,sys2,...)` plots the root loci of multiple LTI models `sys1`, `sys2`,... on a single plot. You can specify a color, line style, and marker for each model. For even more plot customization options, see `rlocusplot`.

`[r,k] = rlocus(sys)` returns the vector of feedback gains k and the complex root locations r for these gains.

`r = rlocus(sys,k)` uses the user-specified vector of feedback gains k to output the closed-loop poles r that define the root locus plot.

Examples

Root Locus Plot of Dynamic System

For this example, plot the root-locus of the following SISO dynamic system:

$$\text{sys}(s) = \frac{2s^2 + 5s + 1}{s^2 + 2s + 3}$$

```
sys = tf([2 5 1],[1 2 3]);
rlocus(sys)
```

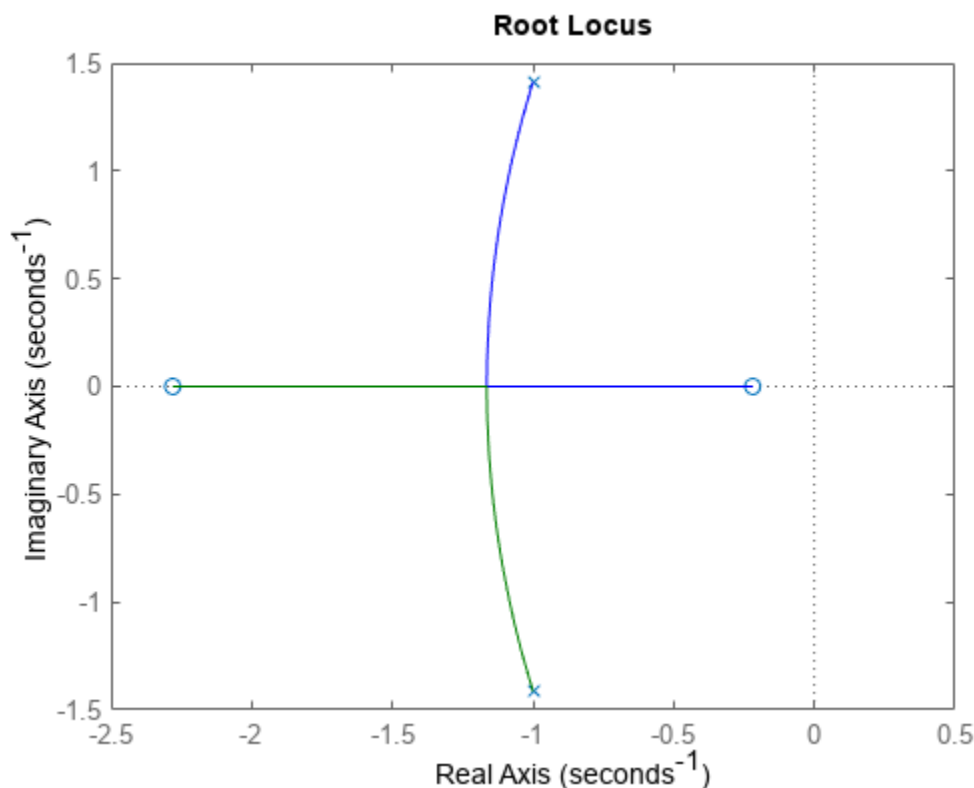

The poles of the system are denoted by **x**, while the zeros are denoted by **o** on the root locus plot. You can use the menu within the generated root locus plot to add grid lines, zoom in or out, and also invoke the Property Editor to customize the plot.

For more plot customization options, use `rlocusplot`.

Root Locus Plot of Multiple Dynamic System Models

For this example, consider `sisoModels.mat` which contains the following three SISO models:

- `sys1` – a transfer function model
- `sys2` – a state-space model
- `sys3` – a zero-pole-gain model

Load the models from the `mat` file.

```
load('sisoModels.mat','sys1','sys2','sys3');
```

Create the root locus plot using `rlocus` and specify the color for each system. Also add a legend to the root locus plot.

```
rlocus(sys1,'b',sys2,'k',sys3,'r')
hold on
legend('sys1','sys2','sys3')
hold off
```

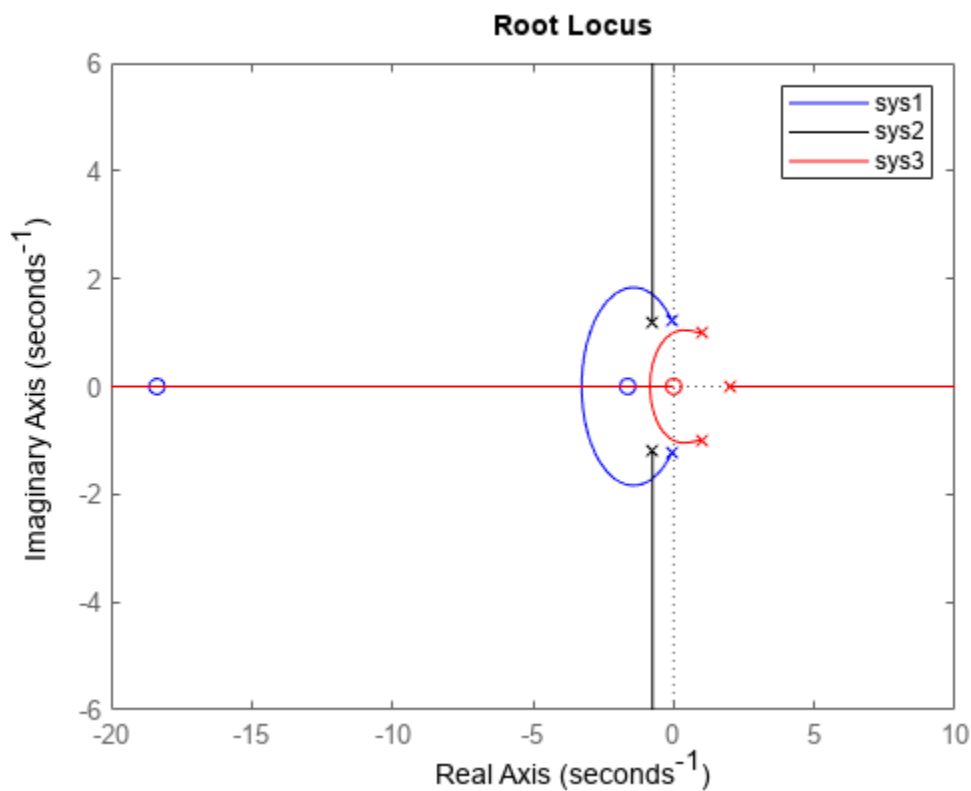

Define the transfer function model and required vector of feedback gain values. For this example, consider a set of gain values varying from 1 to 8 with increments of 0.5 and extract the closed-loop pole locations using `rlocus`.

```
sys = tf([0.5 -1],[4 0 3 0 2]);
k = (1:0.5:5);
r = rlocus(sys,k);
size(r)
```

```
ans = 1×2
```

```
4 9
```

Since `sys` contains 4 closed-loop poles, the size of the resultant array of closed-pole locations `r` is 4x9 where the 9 columns correspond to the 9 specific gain values defined in `k`.

You can also visualize the trajectory of the closed-loop poles for the specific gain values in `k` on the root locus plot.

```
rlocus(sys,k)
```

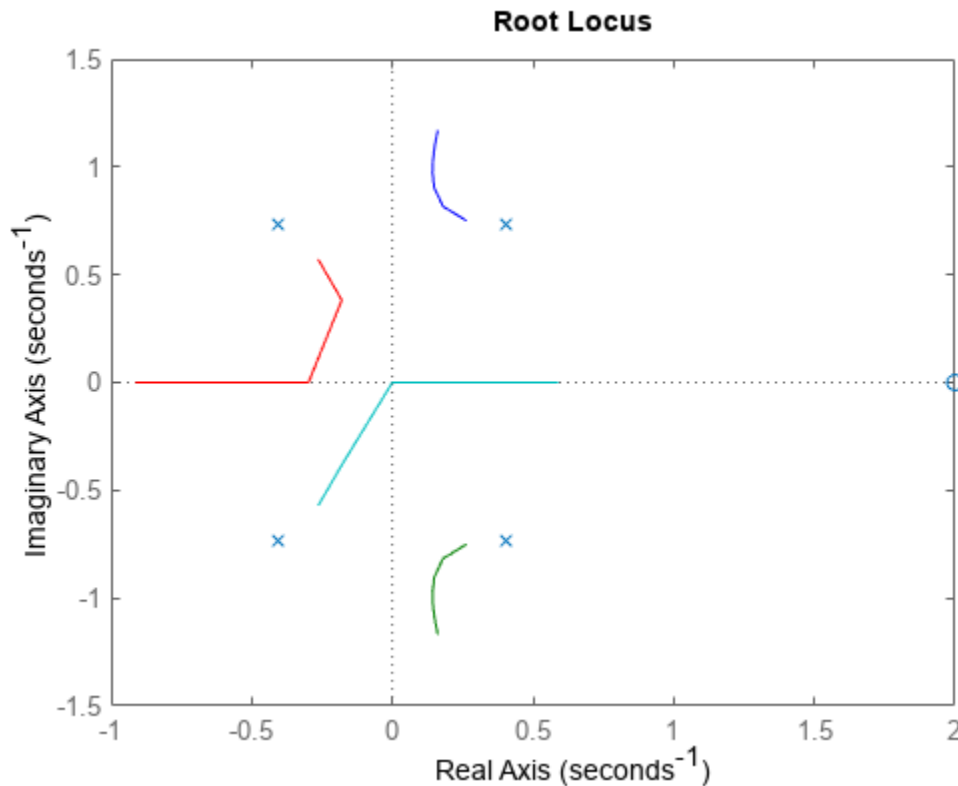

Input Arguments

sys — SISO dynamic system

tf object | ss object | zpk object

SISO dynamic system, specified as one of the following:

- Continuous-time or discrete-time numeric LTI models which include `tf`, `zpk`, or `ss` models.
- Generalized or uncertain LTI models such as `genss` or `uss` models. (Using uncertain models requires Robust Control Toolbox software.)

`rlocus` assumes

- current values of the tunable components for tunable control design blocks.
- nominal model values for uncertain control design blocks.
- Identified LTI models, such as `idtf`, `idss`, `idproc`, `idpoly`, and `idgrey` models. (Using identified models requires System Identification Toolbox software.)

k — Feedback gain values

vector

Feedback gain values that pertain to pole locations, specified as a vector. The feedback gains define the trajectory of the poles thereby affecting the shape of the root locus plot.

Output Arguments

r — Closed-loop pole locations

n-by-m array

Closed-loop pole locations of `sys` corresponding to each value in `k`, returned as an n-by-m array, where `n` is the number of closed-loop poles of `sys` and `m = max(length(k))`.

k — Feedback gain values

vector

Feedback gain values that pertain to pole locations, returned as a vector. The feedback gains define the trajectory of the poles thereby affecting the shape of the root locus plot. When `k` is not defined by the user, `rlocus` adaptively selects a set of positive gains `k` between zero and infinity, to produce a smooth plot.

Tips

- For an interactive approach to root locus plotting, see **Control System Designer**.

Version History

Introduced before R2006a

See Also

`rlocusplot` | `tf` | `pole` | `zero` | `ss` | `zpk` | **Control System Designer**

Topics

“Root Locus Design”

“Control of an Inverted Pendulum on a Cart”

“DC Motor Control”

rlocusplot

Plot root locus and return plot handle

Syntax

```
h = rlocusplot(sys)
rlocusplot(sys,k)
rlocusplot(sys1,sys2,...)
rlocusplot(AX,...)
rlocusplot(..., plotoptions)
```

Description

`h = rlocusplot(sys)` computes and plots the root locus of the single-input, single-output LTI model `sys`. It also returns the plot handle `h`. You can use this handle to customize the plot with the `getoptions` and `setoptions` commands. Type

```
help pzoptions
```

for a list of available plot options.

See `rlocus` for a discussion of the feedback structure and algorithms used to calculate the root locus.

`rlocusplot(sys,k)` uses a user-specified vector `k` of gain values.

`rlocusplot(sys1,sys2,...)` draws the root loci of multiple LTI models `sys1, sys2,...` on a single plot. You can specify a color, line style, and marker for each model, as in

```
rlocusplot(sys1,'r',sys2,'y:',sys3,'gx')
```

`rlocusplot(AX,...)` plots into the axes with handle `AX`.

`rlocusplot(..., plotoptions)` plots the root locus with the options specified in `plotoptions`. Type

```
help pzoptions
```

for more details.

Examples

Use the plot handle to change the title of the plot.

```
sys = rss(3);
h = rlocusplot(sys);
p = getoptions(h); % Get options for plot.
p.Title.String = 'My Title'; % Change title in options.
setoptions(h,p); % Apply options to plot.
```

Tips

You can change the properties of your plot, for example the units. For information on the ways to change properties of your plots, see “Ways to Customize Plots”.

Version History

Introduced before R2006a

See Also

[getoptions](#) | [rlocus](#) | [pzoptions](#) | [setoptions](#)

rsampleBlock

Randomly sample Control Design blocks in generalized model

Syntax

```
Msamp = rsampleBlock(M, names, N)
Msamp = rsampleBlock(M, names1, N1, names2, N2, ..., namesM, NM)
[Msamp, samples] = rsampleBlock( ___ )
```

Description

`Msamp = rsampleBlock(M, names, N)` randomly samples a subset of the Control Design blocks in the generalized model `M`. The `names` argument specifies which blocks to sample, and `N` specifies how many samples to take. The result `Msamp` is a model array of size `[size(M) N]` obtained by replacing the sampled blocks with their randomized values.

`Msamp = rsampleBlock(M, names1, N1, names2, N2, ..., namesM, NM)` takes `N1` samples of the blocks listed in `names1`, `N2` samples of the blocks listed in `names2`, and so on. The result `Msamp` is a model array of size `[size(M) N1 N2 ... NM]`.

`[Msamp, samples] = rsampleBlock(___)` also returns a data structure containing the block replacement values for each sampling point. You can use this syntax with any of the preceding input argument combinations.

Examples

Randomly Sample Parameter in Tunable Model

Create the first-order model $G(s) = 1/(\tau s + 1)$, where τ is a tunable real parameter.

```
tau = realp('tau',5);
G = tf(1,[tau 1]);
```

Restrain `tau` to nonnegative values only.

```
G.Blocks.tau.Minimum = 0;
```

Generate 20 random samples of `G`. The result is a 20-by-1 array of first-order models with random values of `tau` taken from the range of `tau`.

```
Gs = rsampleBlock(G, 'tau', 20);
size(Gs)
```

20x1 array of state-space models.
Each model has 1 outputs, 1 inputs, and 1 states.

Randomly Sample Multiple Parameters

Take random samples of a model with both tunable and uncertain blocks. Using uncertain blocks requires Robust Control Toolbox™. Random sampling of tunable blocks works the same way as shown in this example.

Create an uncertain model of $G(s) = a/(\tau s + 1)$, where a is an uncertain parameter that varies in the interval [3,5], and $\tau = 0.5 \pm 30\%$. Also, create a tunable PI controller, and form a closed-loop system from the tunable controller and uncertain system.

```
a = ureal('a',4);
tau = ureal('tau',.5,'Percentage',30);
G = tf(a,[tau 1]);
C = tunablePID('C','pi');
T = feedback(G*C,1);
```

T is a generalized state-space model with two uncertain blocks, a and τ , and one tunable block, C. Sample T at 20 random (a, τ) pairs.

```
[Ts,samples] = rsampleBlock(T,{'a','tau'},20);
```

Ts is a 20-by-1 array of genss models. The tunable block C, which is not sampled, is preserved in Ts. The structure samples has fields samples.a and samples.tau that contain the values at which those blocks are sampled.

Grouping a and τ into a cell array causes rsampleBlock to sample them together, as (a, τ) pairs. Sampling the blocks independently generates a higher-dimensionality arrays. For example, independently taking 10 random samples of a and 5 samples of τ generates a 10-by-5 model array.

```
[TsInd,samples] = rsampleBlock(T,'a',10,'tau',5);
TsInd
```

```
TsInd =
```

```
10x5 array of generalized continuous-time state-space models.
Each model has 1 outputs, 1 inputs, 2 states, and the following blocks:
C: Tunable PID controller, 1 occurrences.
```

Type "ss(TsInd)" to see the current value, "get(TsInd)" to see all properties, and "TsInd.Blocks"

In this array, a varies along one dimension and τ varies along the other.

Input Arguments

M — Model to sample

generalized model | uncertain model | generalized matrix | uncertain matrix

Model to sample, specified as a:

- Generalized model (genss or genfrd)
- Generalized matrix (genmat)
- Uncertain model (uss or ufrd)
- Uncertain matrix (umat)

names — Control Design blocks

character vector | cell array of character vectors

Control Design blocks to sample, specified as a character vector or cell array of character vectors. The entries in `names` correspond to the names of at least a subset of the Control Design blocks in `M`. For example, suppose that `M` is a `genss` model with tunable blocks `t1` and `t2`, and uncertain blocks `u1` and `u2`. Then, `{ 't1', 'u2' }` is one possible value for `names`.

Grouping block names together in a cell array generates samples of the group rather than independent samples of each block. For example, the following code generates a 10-by-1 array of models, where each entry in the array has a random value for the pair `(t1, u2)`.

```
Msamp = rsampleBlock(M, {'t1', 'u2'}, 10);
```

To sample parameters independently, do not group them. For example, the following code generates a 10-by-20 array of models, where `t1` varies along the first dimension and `u2` varies along the second dimension.

```
Msamp = rsampleBlock(M, 't1', 10, 'u2', 20);
```

`rsampleBlock` ignores any entry in `names` that does not appear in `M`.

N — Number of samples

positive integer

Number of samples to take of the preceding block or blocks, specified as a positive integer.

Output Arguments**Msamp — Array of model samples**generalized model array | `ss` array | `frd` array | numeric array

Array of model samples, returned as a generalized model array, `ss` array, `frd` array, or numeric array. `Msamp` is of the same type as `M`, unless all blocks are sampled. In that case, `Msamp` is a numeric array, `ss` array, or `frd` array. For example, suppose that `M` is a `uss` model with uncertain blocks `u1` and `u2`. The following command returns an array of `uss` models, with uncertain block `u2`.

```
Msamp1 = rsampleBlock(M, 'u1', 10);
```

The following command samples both blocks and returns an array of `ss` models.

```
Msamp2 = rsampleBlock(M, {'u1', 'u2'}, 10);
```

`rsampleBlock` uses values that fall within the uncertainty range when sampling uncertain blocks, and within the maximum and minimum parameter values when sampling tunable blocks.

samples — Block sample values

structure

Block sample values, returned as a structure. The fields of `samples` are the names of the sampled blocks. The values are arrays containing the corresponding random values used to generate the entries in `Msamp`. For instance, suppose that you run the following command, where `M` is a `genss` model with tunable blocks `t1` and `t2`.

```
[Msamp, samples] = rsampleBlock(M, {'t1', 't2'}, 10);
```

Then, `samples.t1` contains the 10 values of `t1` and `samples.t2` contains the 10 values of `t2`. If you sample a block that is not scalar valued, the corresponding field of `samples` contains values compatible with the block. For instance, if you sample a `tunablePID` block, `samples` contains an array of state-space models that represent PID controllers.

Version History

Introduced in R2016a

See Also

`sampleBlock` | `replaceBlock` | `getValue` | `genss` | `genmat` | `uss`

Topics

“Generalized Models”

rss

Generate random continuous test model

Syntax

```
rss(n)
rss(n,p)
rss(n,p,m,s1,...,sn)
```

Description

`rss(n)` generates an n -th order model with one input and one output and returns the model in the state-space object `sys`. The poles of `sys` are random and stable with the possible exception of poles at $s = 0$ (integrators).

`rss(n,p)` generates an n th order model with one input and p outputs, and `rss(n,p,m)` generates an n -th order model with m inputs and p outputs. The output `sys` is always a state-space model.

`rss(n,p,m,s1,...,sn)` generates an s_1 -by-...-by- s_n array of n -th order state-space models with m inputs and p outputs.

Use `tf`, `frd`, or `zpk` to convert the state-space object `sys` to transfer function, frequency response, or zero-pole-gain form.

Examples

Generate State-Space Models

Generate a random SISO state-space model with two states.

```
sys2 = rss(2)
```

```
sys2 =
```

```
A =
      x1      x2
x1  -1.101   0.3733
x2   0.3733  -0.9561
```

```
B =
      u1
x1   0.7254
x2  -0.06305
```

```
C =
      x1      x2
y1     0  -0.205
```

```
D =
      u1
```

```
y1 -0.1241
```

Continuous-time state-space model.

Generate a model with four states, three outputs, and two inputs. The input arguments to `rss` are arranged in the order states, outputs, inputs.

```
sys4 = rss(4,3,2)
```

```
sys4 =
```

```
A =
      x1      x2      x3      x4
x1 -0.6722 -3.145 -4.692 -4.391
x2  2.312 -0.3352  8.041  6.791
x3  5.398 -7.51 -0.5229  1.114
x4  4.087 -7.059 -0.3362 -0.4294
```

```
B =
      u1      u2
x1      0 -0.2256
x2  1.533      0
x3 -0.7697      0
x4      0  0.03256
```

```
C =
      x1      x2      x3      x4
y1  0.5525  0.08593 -1.062  0.7481
y2  1.101      0      2.35 -0.1924
y3  1.544      0 -0.6156  0.8886
```

```
D =
      u1      u2
y1      0  0.4882
y2 -1.402      0
y3      0 -0.1961
```

Continuous-time state-space model.

Generate Array of Random Models

Generate a 4-by-5 array of SISO models with three states each.

```
sysarray = rss(3,1,1,4,5);
size(sysarray)
```

4x5 array of state-space models.
Each model has 1 outputs, 1 inputs, and 3 states.

Version History

Introduced before R2006a

See Also

drss | frd | tf | zpk

sampleBlock

Sample Control Design blocks in generalized model

Syntax

```
Msamp = sampleBlock(M,name,vals)
Msamp = sampleBlock(M,nameset,valset)
Msamp = sampleBlock(M,nameset1,valset1,nameset2,valset2,...,namesetM,valsetM)
[Msamp,samples] = sampleBlock( ___ )
```

Description

`Msamp = sampleBlock(M,name,vals)` samples one Control Design block in the generalized model `M`. The result `Msamp` is a model array of size `[size(M) N]` obtained by replacing the block with the specified values, where `N` is the number of values in `vals`.

`Msamp = sampleBlock(M,nameset,valset)` concurrently samples multiple blocks specified as a cell array of block names. `valset` is a cell array of `N` sample values for each block. The result `Msamp` is a model array of size `[size(M) N]`.

`Msamp = sampleBlock(M,nameset1,valset1,nameset2,valset2,...,namesetM,valsetM)` independently samples multiple blocks. `nameset1, nameset2, ..., namesetM` can each be a single block name (see `name`) or a cell array of names (see `nameset`). The model `M` is sampled over a grid of size `[N1 N2 ... NM]`, where `N1` is the number of values in `valset1`, `N2` is the number of values in `valset2`, and so on. The resulting `Msamp` is an array of size `[size(M) N1 N2 ... NM]`.

`[Msamp,samples] = sampleBlock(___)` also returns a data structure containing the block replacement values for each sampling point. You can use this syntax with any of the preceding input argument combinations.

Examples

Sample Real Parameter in Tunable Model

Create the first-order model $G(s) = 1/(\tau s + 1)$, where τ is a tunable real parameter.

```
tau = realp('tau',5);
G = tf(1,[tau 1]);
```

Evaluate this transfer function for $\tau = 3,4,\dots,7$. The result is a 5-by-1 array of first-order models.

```
Gs = sampleBlock(G,'tau',3:7);
size(Gs)
```

```
5x1 array of state-space models.
Each model has 1 outputs, 1 inputs, and 1 states.
```

Sample Multiple Parameters in Tunable Model

Create a model with a pole at $s = a$ and a gain of $b*c$, where a , b , and c are tunable scalars.

```
a = realp('a',1);
b = realp('b',3);
c = realp('c',1);
G = tf(b*c,[1 a]);
```

Pick 5 samples for a and 3 samples for (b, c) pairs. Evaluate G over the corresponding 5-by-3 grid of (a, b, c) combinations.

```
as = 0.8:0.1:1.2;
bs = 2:4;
cs = [0.5 1 1.5];
Gs = sampleBlock(G, 'a', as, {'b', 'c'}, {bs, cs});
```

Grouping the values for b and c in cell arrays causes `sampleBlock` to treat them as the (b, c) pairs, (2,0.5), (3,1), and (1,5). G_s is a 5-by-3 array of state-space models, in which a varies along the first dimension and (b, c) varies along the second dimension. Thus, for example, $G_s(:, :, 3, 2)$ corresponds to $a = 1$, $(b, c) = (3, 1)$.

A step plot shows a set of responses for each of the three (b, c) pairs. Each set contains a response for each of the five a values.

```
stepplot(Gs)
```

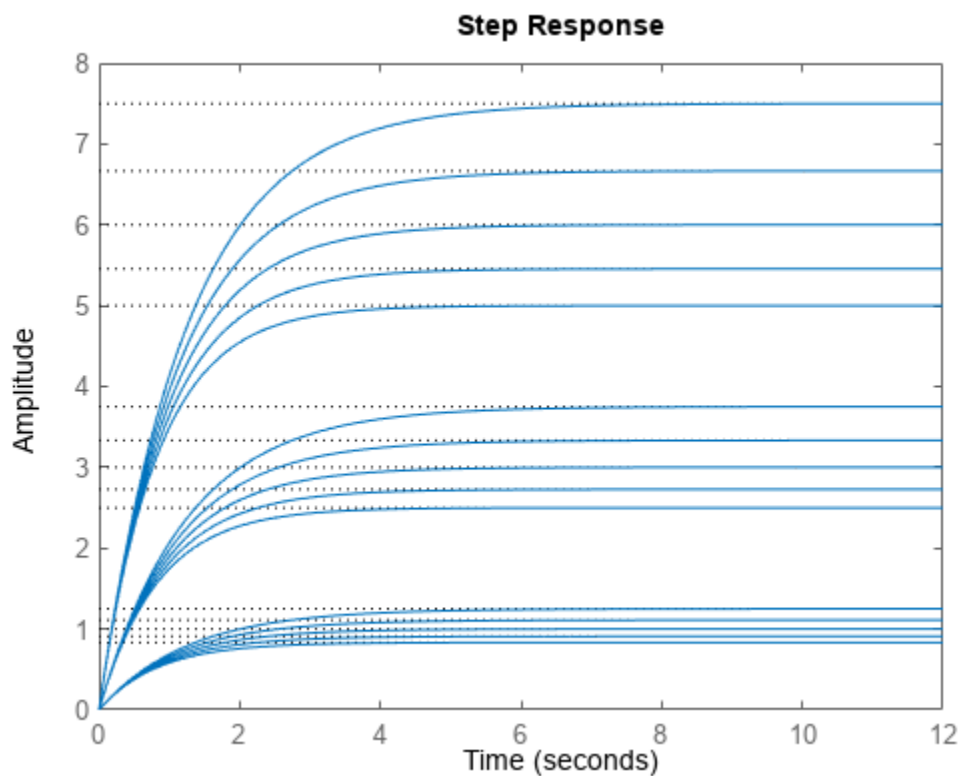

If you do not group the values, `sampleBlock` replaces all values independently, resulting in a 5-by-3-by-3 model array.

```
GsInd = sampleBlock(G, 'a', as, 'b', bs, 'c', cs);
size(GsInd)
```

5x3x3 array of state-space models.
Each model has 1 outputs, 1 inputs, and 1 states.

For example, in `GsInd`, `Gs(:, :, 3, 2, 1)` is a model with $a = 1$, $b = 3$, and $c = 0.5$.

Input Arguments

M — Model to sample

generalized model | uncertain model | generalized matrix | uncertain matrix

Model to sample, specified as a:

- Generalized model (`genss` or `genfrd`)
- Generalized matrix (`genmat`)
- Uncertain model (`uss` or `ufrd`)
- Uncertain matrix (`umat`)

name — Control Design block

character vector

Control Design block to sample, specified as a character vector. For example, suppose that `M` is a `genss` model with tunable blocks `t1` and `t2`. Then, either `'t1'` or `'t2'` is a possible value for `name`.

vals — Sample block values

numeric array | model array

Sample block values, specified as a numeric array or a model array. Values must be compatible with the block type. For example, if `name` is a tunable real parameter (`realp`), then `vals` is a numerical array of length `N`, the number of samples. If `name` is a tunable PID controller (`tunablePID`), then `vals` is an array of LTI models compatible with PID structure.

nameset — Control Design blocks

cell array of character vectors

Control Design blocks to sample concurrently, specified as cell array of character vectors. The entries in `nameset` correspond to the names of at least a subset of the Control Design blocks in `M`. For example, suppose that `M` is a `genss` model with tunable blocks `t1` and `t2`, and uncertain blocks `u1` and `u2`. Then, `{'t1', 'u2'}` is one possible value for `nameset`.

Grouping block names together in a cell array generates samples of the group rather than independent samples. For example, the following code generates a 10-by-1 array of models, where each entry in the array has the corresponding value for the pair `(t1, u2)`.

```
t1s = 1:10;
u2s = 2:2:20;
valset = {t1s, t2s};
Msamp = sampleBlock(M, {'t1', 'u2'}, valset);
```

`sampleBlock` ignores any entry in `nameset` that does not appear in `M`.

valset — Sample block values

cell array

Sample block values, specified as a cell array. Each entry in the cell array is itself an array of `N` sample values for each block in `nameset`. For example, the following code samples a model `M` at the `(t1,u2)` pairs (1,2), (2,4), ... (10,20).

```
t1s = 1:10;
u2s = 2:2:20;
valset = {t1s,t2s};
Msamp = sampleBlock(M,{'t1','u2'},valset);
```

Values in `valset` must be compatible with the corresponding block type.

Output Arguments

Msamp — Array of model samples

generalized model array | `ss` array | `frd` array | numeric array

Array of model samples, returned as a generalized model array, `ss` array, `frd` array, or numeric array. `Msamp` is of the same type as `M`, unless all blocks are sampled. In that case, `Msamp` is a numeric array, `ss` array, or `frd` array. For example, suppose that `M` is a `uss` model with uncertain blocks `u1` and `u2`. The following command returns an array of `uss` models, with uncertain block `u2`.

```
Msamp1 = sampleBlock(M,'u1',1:10);
```

The following command samples both blocks and returns an array of `ss` models.

```
Msamp2 = sampleBlock(M,{'u1','u2'},{1:10,2:20});
```

samples — Block sample values

structure

Block sample values, returned as a structure. The fields of `samples` are the names of the sampled blocks. The values are arrays containing the corresponding values used to generate the entries in `Msamp`.

Version History

Introduced in R2016a

See Also

`replaceBlock` | `rsampleBlock` | `getValue` | `genss` | `genmat` | `uss`

Topics

“Study Parameter Variation by Sampling Tunable Model”

“Generalized Models”

sectorplot

Compute or plot sector index as function of frequency

Syntax

```
sectorplot(H,Q)
sectorplot(H,Q,w)
sectorplot(H1,H2,...,HN,Q)
sectorplot(H1,H2,...,HN,Q,w)
sectorplot(H1,LineSpec1,...,HN,LineSpecN,Q)
sectorplot(H1,LineSpec1,...,HN,LineSpecN,Q,w)
sectorplot( ___,plotoptions)
```

```
[index,wout] = sectorplot(H,Q)
index = sectorplot(H,Q,w)
```

Description

`sectorplot(H,Q)` plots the relative sector indices for the dynamic system H and a given sector matrix Q . These indices measure by how much the sector bound is satisfied (index less than 1) or violated (index greater than 1) at a given frequency. (See “About Sector Bounds and Sector Indices” for more information about the meaning of the sector index.) `sectorplot` automatically chooses the frequency range and number of points based on the dynamics of H .

Let the following be an orthogonal decomposition of the symmetric matrix Q into its positive and negative parts.

$$Q = W_1 W_1^T - W_2 W_2^T, \quad W_1^T W_2 = 0.$$

The sector index plot is only meaningful if $W_2^T H$ has a proper stable inverse. In that case, the sector indices are the singular values of:

$$\left(W_1^T H(j\omega) \right) \left(W_2^T H(j\omega) \right)^{-1}.$$

If H is a model with complex coefficients, then in:

- Log frequency scale, the plot shows two branches, one for positive frequencies and one for negative frequencies. The arrows indicate the direction of increasing frequency values for each branch.
- Linear frequency scale, the plot shows a single branch with a symmetric frequency range centered at a frequency value of zero.

`sectorplot(H,Q,w)` plots the sector index for frequencies specified by w .

- If w is a cell array of the form $\{w_{\min}, w_{\max}\}$, then `sectorplot` plots the sector index at frequencies ranging between w_{\min} and w_{\max} .
- If w is a vector of frequencies, then `sectorplot` plots the sector index at each specified frequency. The vector w can contain both negative and positive frequencies.

`sectorplot(H1,H2,...,HN,Q)` and `sectorplot(H1,H2,...,HN,Q,w)` plot the sector index for multiple dynamic systems H_1, H_2, \dots, H_N on the same plot.

`sectorplot(H1,LineStyle1,...,HN,LineStyleN,Q)` and `sectorplot(H1,LineStyle1,...,HN,LineStyleN,Q,w)` specify a color, linestyle, and marker for each system in the plot.

`sectorplot(____,plotoptions)` plots the sector index with the options set specified in `plotoptions`. You can use these options to customize the plot appearance using the command line. Settings you specify in `plotoptions` override the preference settings in the MATLAB session in which you run `sectorplot`. Therefore, this syntax is useful when you want to write a script to generate multiple plots that look the same regardless of the local preferences.

`[index,wout] = sectorplot(H,Q)` returns the sector index at each frequency in the vector `wout`. The output `index` is a matrix, and the value `index(:,k)` gives the sector indices in descending order at the frequency $w(k)$. This syntax does not draw a plot.

`index = sectorplot(H,Q,w)` returns the sector indices at the frequencies specified by `w`.

Examples

Plot Sector Index Versus Frequency

Plot the sector index to visualize the frequencies at which the I/O trajectories of $G(s) = (s + 2)/(s + 1)$ lie within the sector defined by:

$$S = \{(y, u): 0.1u^2 < uy < 10u^2\}.$$

In U/Y space, this sector is the shaded region of the following diagram.

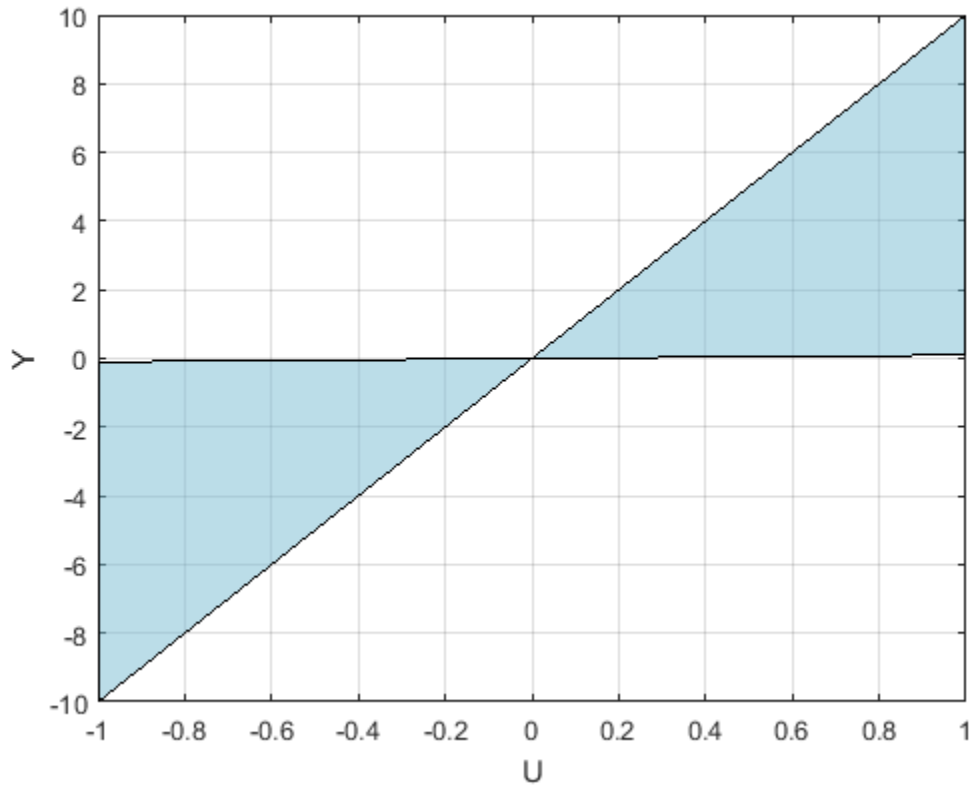

The Q matrix for this sector is given by:

$$\begin{aligned} a &= 0.1; \\ b &= 10; \\ Q &= [1 \quad -(a+b)/2 \quad ; \quad -(a+b)/2 \quad a*b]; \end{aligned}$$

A trajectory $y(t) = Gu(t)$ lies within the sector S when for all $T > 0$,

$$0.1 \int_0^T u(t)^2 dt < \int_0^T u(t)y(t) dt < 10 \int_0^T u(t)^2 dt.$$

In the frequency domain, this same condition can be expressed as:

$$\begin{pmatrix} G(j\omega) \\ 1 \end{pmatrix}^H Q \begin{pmatrix} G(j\omega) \\ 1 \end{pmatrix} < 0.$$

To check whether G satisfies or violates this condition at any frequency, plot the sector index for $H = [G; 1]$.

```
G = tf([1 2],[1 1]);
sectorplot([G;1],Q)
```

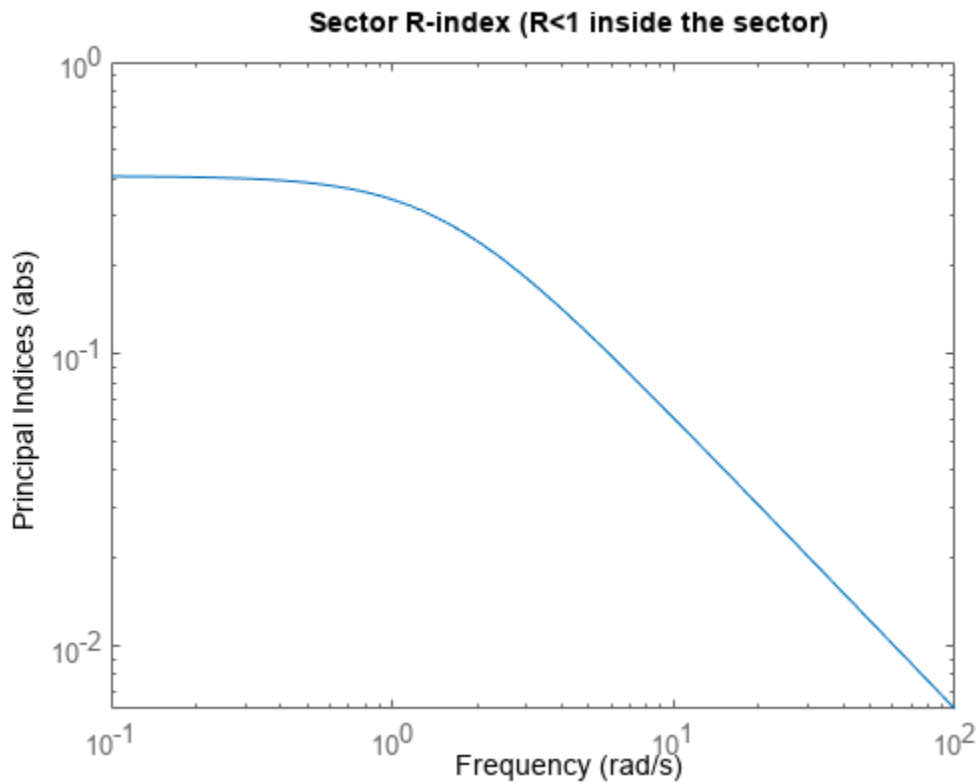

The plot shows that the sector index is less than 1 at all frequencies. Therefore, the trajectories of $G(s)$ fit within in the specified sector Q at all frequencies.

Sector Plot with MIMO System

Examine the sector plot of a 2-output, 2-input system for a particular sector.

```
rng(4, 'twister');
H = rss(3,4,2);
Q = [-5.12  2.16 -2.04  2.17
      2.16 -1.22 -0.28 -1.11
      -2.04 -0.28 -3.35  0.00
      2.17 -1.11  0.00  0.18];
sectorplot(H,Q)
```

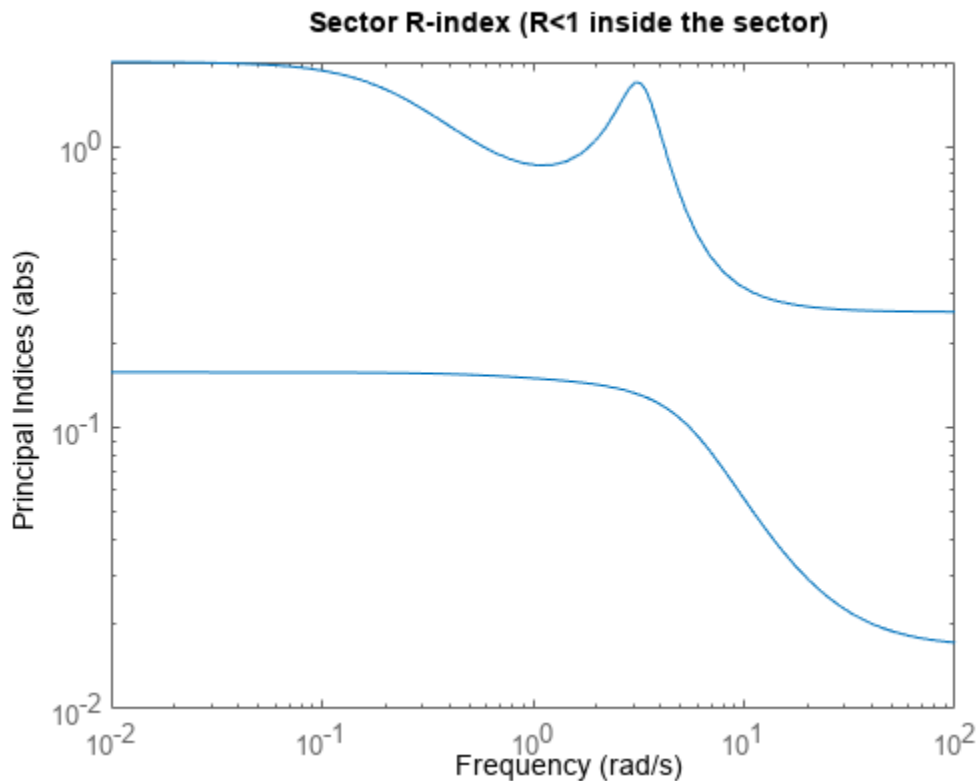

Because H is 2-by-2, there are two lines on the sector plot. The largest value of the sector index exceeds 1 below about 0.5 rad/s and in a narrow band around 3 rad/s. Therefore, H does not satisfy the sector bound represented by Q .

Plot Sector Index of Model with Complex Coefficients

Plot the relative sector indices of a model with complex coefficients and a model with real coefficients on the same plot.

```
rng(0)
A = [-3.50, -1.25-0.25i; 2, 0];
B = [1; 0];
C = [-0.75-0.5i, 0.625-0.125i];
D = 0.5;
Hc = [ss(A,B,C,D); 1];
Hr = [rss(5); 1];
Q = [1 0.1; 0.1 -1];
sectorplot(Hc,Hr,Q)
legend('Complex-coefficient model', 'Real-coefficient model', 'Location', 'southwest')
```

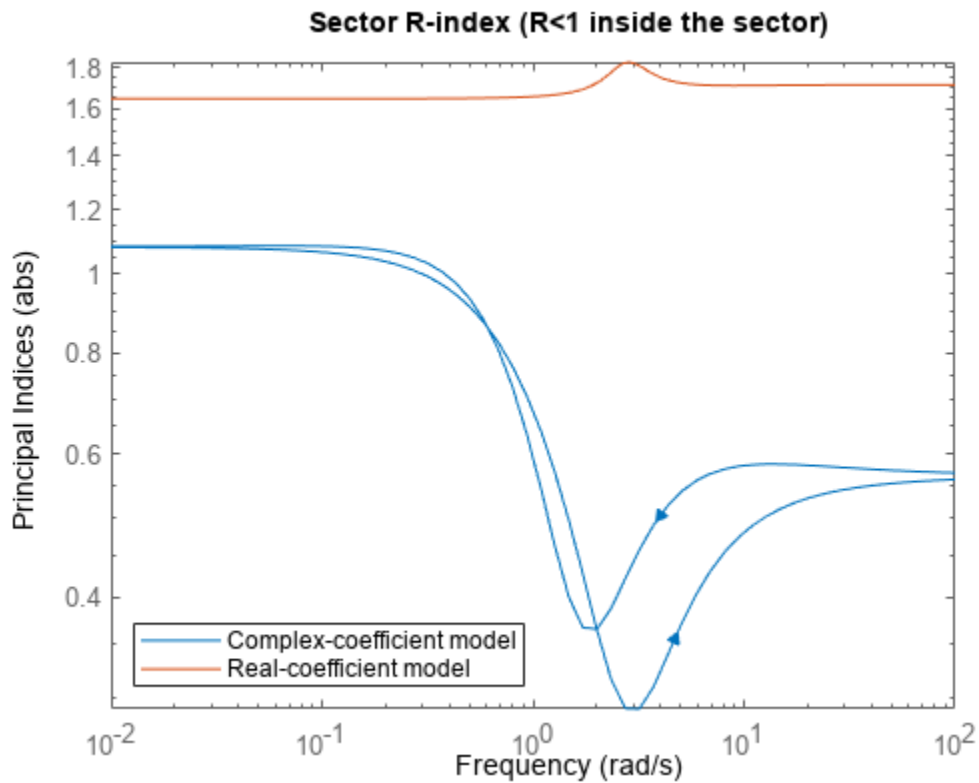

In log frequency scale, the plot shows two branches for models with complex coefficients, one for positive frequencies, with a right-pointing arrow, and one for negative frequencies, with a left-pointing arrow. In both branches, the arrows indicate the direction of increasing frequencies. The plots for models with real coefficients always contain a single branch with no arrows.

Set the plotting frequency scale to linear.

```
opt = sectorplotoptions;
opt.FreqScale = 'Linear';
```

Plot the indices.

```
sectorplot(Hc,Hr,Q,opt)
legend('Complex-coefficient model','Real-coefficient model','Location','southwest')
```

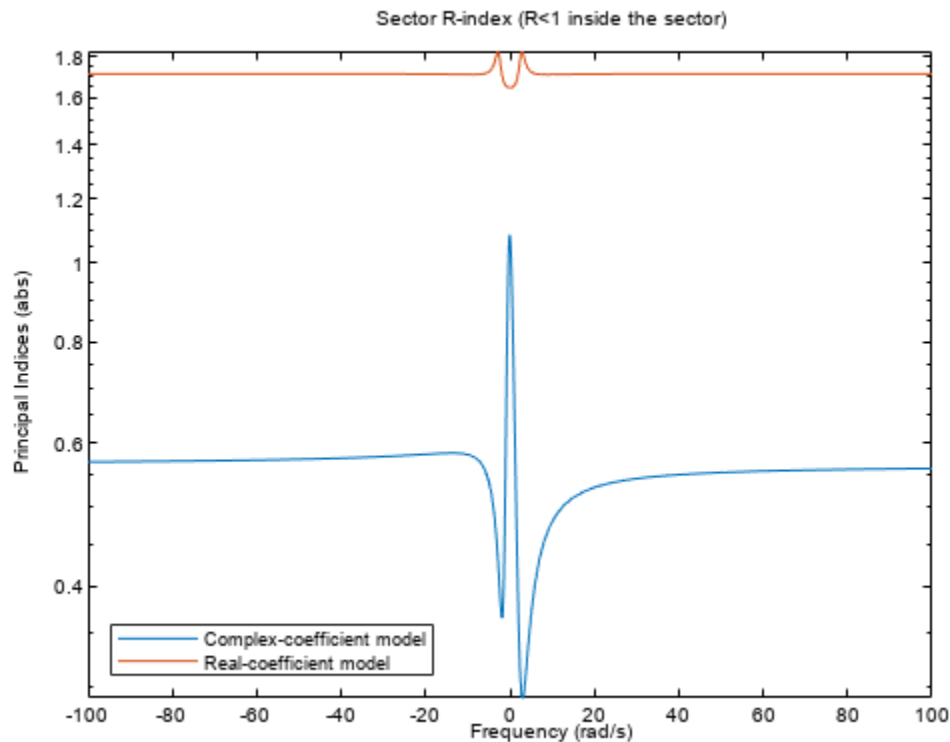

In linear frequency scale, the plots show a single branch with a symmetric frequency range centered at a frequency value of zero. The plot also shows the negative-frequency response of a model with real coefficients when you plot the response along with a model with complex coefficients.

Input Arguments

H — Model to analyze

dynamic system model | model array

Model to analyze against sector bounds, specified as a dynamic system model such as a `tf`, `ss`, or `genss` model. `H` can be continuous or discrete. If `H` is a generalized model with tunable or uncertain blocks, `sectorplot` analyzes the current, nominal value of `H`.

To analyze whether all I/O trajectories $(u(t), y(t))$ of a linear system G lie in a particular sector, use $H = [G; I]$, where $I = \text{eyes}(nu)$, and nu is the number of inputs of G .

If `H` is a model array, then `sectorplot` plots the sector index of all models in the array on the same plot. When you use output arguments to get sector-index data, `H` must be a single model.

Q — Sector geometry

matrix | LTI model

Sector geometry, specified as:

- A matrix, for constant sector geometry. Q is a symmetric square matrix that is n_y on a side, where n_y is the number of outputs of H .
- An LTI model, for frequency-dependent sector geometry. Q satisfies $Q(s)' = Q(-s)$. In other words, $Q(s)$ evaluates to a Hermitian matrix at each frequency.

The matrix Q must be indefinite to describe a well-defined conic sector. An indefinite matrix has both positive and negative eigenvalues.

For more information, see “About Sector Bounds and Sector Indices”.

w — Frequencies

{wmin, wmax} | vector

Frequencies at which to compute and plot indices, specified as the cell array {wmin, wmax} or as a vector of frequency values.

- If w is a cell array of the form {wmin, wmax}, then the function computes the index at frequencies ranging between wmin and wmax.
- If w is a vector of frequencies, then the function computes the index at each specified frequency. For example, use `logspace` to generate a row vector with logarithmically-spaced frequency values.

For models with complex coefficients, if you specify a frequency range of $[w_{\min}, w_{\max}]$ for your plot, then in:

- Log frequency scale, the plot frequency limits are set to $[w_{\min}, w_{\max}]$ and the plot shows two branches, one for positive frequencies $[w_{\min}, w_{\max}]$ and one for negative frequencies $[-w_{\max}, -w_{\min}]$.
- Linear frequency scale, the plot frequency limits are set to $[-w_{\max}, w_{\max}]$ and the plot shows a single branch with a symmetric frequency range centered at a frequency value of zero.

Specify frequencies in units of $\text{rad}/\text{TimeUnit}$, where `TimeUnit` is the `TimeUnit` property of the model.

LineStyle — Line style, marker, and color

character vector | string

Line style, marker, and color, specified as a string or vector of one, two, or three characters. The characters can appear in any order. You do not need to specify all three characteristics (line style, marker, and color). For example, if you omit the line style and specify the marker, then the plot shows only the marker and no line. For more information about configuring this argument, see the `LineStyle` input argument of the `plot` function.

Example: 'r--' specifies a red dashed line

Example: '*b' specifies blue asterisk markers

Example: 'y' specifies a yellow line

plotoptions — Sector index plot options set

SectorPlotOptions object

Sector index plot options set, specified as a `SectorPlotOptions` object. You can use this option set to customize the plot appearance. Use `sectorplotoptions` to create the option set. Settings you specify in `plotoptions` overrides the preference settings in the MATLAB session in which you run

sectorplot. Therefore, `plotoptions` is useful when you want to write a script to generate multiple plots that look the same regardless of the local preferences.

For the list of available options, see `sectorplotoptions`.

Output Arguments

index — Sector indices

matrix

Sector indices as a function of frequency, returned as a matrix. `index` contains the sector indices computed at the frequencies `w` if you supplied them, or `wout` if you did not. `index` has as many columns as there are values in `w` or `wout`, and as many rows as `H` has inputs. Thus the value `index(:,k)` gives the sector indices in descending order at the frequency `w(k)`.

For example, suppose that `G` is a 3-input, 3-output system, `Q` is a suitable sector matrix, and `w` is a 1-by-30 vector of frequencies, then the following syntax returns a 3-by-30 matrix `index`.

```
H = [G;eyes(3)]
index = sectorplot(H,Q,w);
```

The entry `index(:,k)` contains the three sector indices for `H`, in descending order, at the frequency `w(k)`.

For more information, see “About Sector Bounds and Sector Indices”.

wout — Frequencies

vector

Frequencies at which the indices are calculated, returned as a vector. The function automatically chooses the frequency range and number of points based on the dynamics of the model.

`wout` also contains negative frequency values for models with complex coefficients.

Version History

Introduced in R2016a

See Also

`sectorplotoptions` | `getSectorIndex` | `getPassiveIndex` | `passiveplot`

Topics

“About Sector Bounds and Sector Indices”

sectorplotoptions

Create list of relative index plot options

Description

Use the `sectorplotoptions` command to create a `SectorPlotOptions` object to customize your sector plot appearance. You can also use the command to override the plot preference settings in the MATLAB session in which you create the sector plots.

Creation

Syntax

```
plotoptions = sectorplotoptions  
plotoptions = sectorplotoptions('cstprefs')
```

Description

`plotoptions = sectorplotoptions` returns a default set of plot options for use with the `passiveplot` and `sectorplot` commands. You can use these options to customize the plot appearance using the command line. This syntax is useful when you want to write a script to generate plots that look the same regardless of the preference settings of the MATLAB session in which you run the script.

`plotoptions = sectorplotoptions('cstprefs')` initializes the plot options with the options you selected in the Control System Toolbox Preferences Editor. For more information about the editor, see “Toolbox Preferences Editor”. This syntax is useful when you want to change a few plot options but otherwise use your default preferences. A script that uses this syntax can generate results that look different when run in a session with different preferences.

Properties

FreqUnits — Frequency units

'rad/s' (default)

Frequency units, specified as one of the following values:

- 'Hz'
- 'rad/s'
- 'rpm'
- 'kHz'
- 'MHz'
- 'GHz'
- 'rad/nanosecond'

- 'rad/microsecond'
- 'rad/millisecond'
- 'rad/minute'
- 'rad/hour'
- 'rad/day'
- 'rad/week'
- 'rad/month'
- 'rad/year'
- 'cycles/nanosecond'
- 'cycles/microsecond'
- 'cycles/millisecond'
- 'cycles/hour'
- 'cycles/day'
- 'cycles/week'
- 'cycles/month'
- 'cycles/year'

FreqScale — Frequency scale

'log' (default) | 'linear'

Frequency scale, specified as either 'log' or 'linear'.

IndexScale — Index scale

'log' (default) | 'linear'

Index scale, specified as either 'log' or 'linear'.

IOWGrouping — Input-output pair grouping

'none' (default) | 'inputs' | 'outputs' | 'all'

Grouping of input-output (I/O) pairs, specified as one of the following:

- 'none' — No input-output grouping.
- 'inputs' — Group only the inputs.
- 'outputs' — Group only the outputs.
- 'all' — Group all the I/O pairs.

InputLabels — Input label style

structure

Input label style, specified as a structure with the following fields:

- **FontSize** — Font size, specified as a scalar value greater than zero in point units. The default font size depends on the specific operating system and locale. One point equals 1/72 inches.
- **FontWeight** — Character thickness, specified as 'Normal' or 'bold'. MATLAB uses the **FontWeight** property to select a font from those available on your system. Not all fonts have a bold weight. Therefore, specifying a bold font weight can still result in the normal font weight.

- **FontAngle** — Character slant, specified as 'Normal' or 'italic'. Not all fonts have both font styles. Therefore, the italic font might look the same as the normal font.
- **Color** — Text color, specified as an RGB triplet. The default color is dark grey with the RGB triplet `[0.4, 0.4, 0.4]`.
- **Interpreter** — Text interpreter, specified as one of these values:
 - 'tex' — Interpret characters using a subset of TeX markup. This is the default value of **Interpreter**.
 - 'latex' — Interpret characters using LaTeX markup.
 - 'none' — Display literal characters.

OutputLabels — Output label style

structure

Output label style, specified as a structure with the following fields:

- **FontSize** — Font size, specified as a scalar value greater than zero in point units. The default font size depends on the specific operating system and locale. One point equals 1/72 inches.
- **FontWeight** — Character thickness, specified as 'Normal' or 'bold'. MATLAB uses the **FontWeight** property to select a font from those available on your system. Not all fonts have a bold weight. Therefore, specifying a bold font weight can still result in the normal font weight.
- **FontAngle** — Character slant, specified as 'Normal' or 'italic'. Not all fonts have both font styles. Therefore, the italic font might look the same as the normal font.
- **Color** — Text color, specified as an RGB triplet. The default color is dark grey with the RGB triplet `[0.4, 0.4, 0.4]`.
- **Interpreter** — Text interpreter, specified as one of these values:
 - 'tex' — Interpret characters using a subset of TeX markup. This is the default value of **Interpreter**.
 - 'latex' — Interpret characters using LaTeX markup.
 - 'none' — Display literal characters.

InputVisible — Input display toggle

{'on'} (default) | {'off'} | cell array

Toggle display of inputs, specified as {'on'}, {'off'}, or a cell array with multiple elements.

OutputVisible — Output display toggle

{'on'} (default) | {'off'} | cell array

Toggle display of outputs, specified as {'on'}, {'off'}, or a cell array with multiple elements.

Title — Title text and style

structure

Title text and style, specified as a structure with the following fields:

- **String** — Label text, specified as a character vector. By default, the plot is titled 'Singular Values'.
- **FontSize** — Font size, specified as a scalar value greater than zero in point units. The default font size depends on the specific operating system and locale. One point equals 1/72 inches.

- **FontWeight** — Character thickness, specified as 'Normal' or 'bold'. MATLAB uses the **FontWeight** property to select a font from those available on your system. Not all fonts have a bold weight. Therefore, specifying a bold font weight can still result in the normal font weight.
- **FontAngle** — Character slant, specified as 'Normal' or 'italic'. Not all fonts have both font styles. Therefore, the italic font might look the same as the normal font.
- **Color** — Text color, specified as an RGB triplet. The default color is black, as specified by the RGB triplet $[0, 0, 0]$.
- **Interpreter** — Text interpreter, specified as one of these values:
 - 'tex' — Interpret characters using a subset of TeX markup. This is the default value of **Interpreter**.
 - 'latex' — Interpret characters using LaTeX markup.
 - 'none' — Display literal characters.

XLabel — X-axis label text and style

structure (default)

X-axis label text and style, specified as a structure with the following fields:

- **String** — Label text, specified as a character vector. By default, the axis is titled based on the frequency units **FreqUnits**.
- **FontSize** — Font size, specified as a scalar value greater than zero in point units. The default font size depends on the specific operating system and locale. One point equals 1/72 inches.
- **FontWeight** — Character thickness, specified as 'Normal' or 'bold'. MATLAB uses the **FontWeight** property to select a font from those available on your system. Not all fonts have a bold weight. Therefore, specifying a bold font weight can still result in the normal font weight.
- **FontAngle** — Character slant, specified as 'Normal' or 'italic'. Not all fonts have both font styles. Therefore, the italic font might look the same as the normal font.
- **Color** — Text color, specified as an RGB triplet. The default color is black, as specified by the RGB triplet $[0, 0, 0]$.
- **Interpreter** — Text interpreter, specified as one of these values:
 - 'tex' — Interpret characters using a subset of TeX markup. This is the default value of **Interpreter**.
 - 'latex' — Interpret characters using LaTeX markup.
 - 'none' — Display literal characters.

YLabel — Y-axis label text and style

structure (default)

Y-axis label text and style, specified as a structure with the following fields:

- **String** — Label text, specified as a cell array of character vectors. By default, the axis is titled based on the magnitude units **MagUnits**.
- **FontSize** — Font size, specified as a scalar value greater than zero in point units. The default font size depends on the specific operating system and locale. One point equals 1/72 inches.
- **FontWeight** — Character thickness, specified as 'Normal' or 'bold'. MATLAB uses the **FontWeight** property to select a font from those available on your system. Not all fonts have a bold weight. Therefore, specifying a bold font weight can still result in the normal font weight.

- **FontAngle** — Character slant, specified as 'Normal' or 'italic'. Not all fonts have both font styles. Therefore, the italic font might look the same as the normal font.
- **Color** — Text color, specified as an RGB triplet. The default color is black, as specified by the RGB triplet [0,0,0].
- **Interpreter** — Text interpreter, specified as one of these values:
 - 'tex' — Interpret characters using a subset of TeX markup. This is the default value of Interpreter.
 - 'latex' — Interpret characters using LaTeX markup.
 - 'none' — Display literal characters.

TickLabel — Tick label style

structure (default)

Tick label style, specified as a structure with the following fields:

- **FontSize** — Font size, specified as a scalar value greater than zero in point units. The default font size depends on the specific operating system and locale. One point equals 1/72 inches.
- **FontWeight** — Character thickness, specified as 'Normal' or 'bold'. MATLAB uses the **FontWeight** property to select a font from those available on your system. Not all fonts have a bold weight. Therefore, specifying a bold font weight can still result in the normal font weight.
- **FontAngle** — Character slant, specified as 'Normal' or 'italic'. Not all fonts have both font styles. Therefore, the italic font might look the same as the normal font.
- **Color** — Text color, specified as an RGB triplet. The default color is black, as specified by the RGB triplet [0,0,0].

Grid — Toggle grid display

'off' (default) | 'on'

Toggle grid display on the plot, specified as either 'off' or 'on'.

GridColor — Grid line color

[0.15,0.15,0.15] (default) | RGB triplet

Color of the grid lines, specified as an RGB triplet. The default color is light grey, as specified by the RGB triplet [0.15,0.15,0.15].

XLimMode — X-axis limit selection mode

'auto' (default) | {'manual'} | cell array

Selection mode for the x-axis limits, specified as one of these values:

- 'auto' — Enable automatic limit selection, which is based on the total span of the plotted data.
- 'manual' — Manually specify the axis limits. To specify the axis limits, set the **XLim** property.

YLimMode — Y-axis limit selection mode

'auto' (default) | {'manual'} | cell array

Selection mode for the y-axis limits, specified as one of these values:

- 'auto' — Enable automatic limit selection, which is based on the total span of the plotted data.

- 'manual' — Manually specify the axis limits. To specify the axis limits, set the YLim property.

XLim — X-axis limits

'{[1,10]}' (default) | cell array containing two-element vector of the form [min,max]

X-axis limits, specified as a cell array containing a two-element vector of the form [min,max].

YLim — Y-axis limits

'{[1,10]}' (default) | cell array containing two-element vector of the form [min,max]

Y-axis limits, specified as a cell array containing a two-element vector of the form [min,max].

Object Functions

passiveplot Compute or plot passivity index as function of frequency
sectorplot Compute or plot sector index as function of frequency

Examples

Custom Passivity Index Plot Settings Independent of Preferences

For this example, create a passivity index plot that uses 15-point red text for the title. This plot looks the same in any MATLAB® session, regardless of the preferences of the one in which it is generated.

First, create a default options set using sectorplotoptions.

```
plotoptions = sectorplotoptions;
```

Next, change the required properties of the options set plotoptions.

```
plotoptions.Title.FontSize = 15;  
plotoptions.Title.Color = [1 0 0];  
plotoptions.FreqUnits = 'Hz';  
plotoptions.Grid = 'on';
```

Now, create a passivity index plot using the options set plotoptions.

```
G = tf(1,[1 1]);  
passiveplot(G,plotoptions)
```

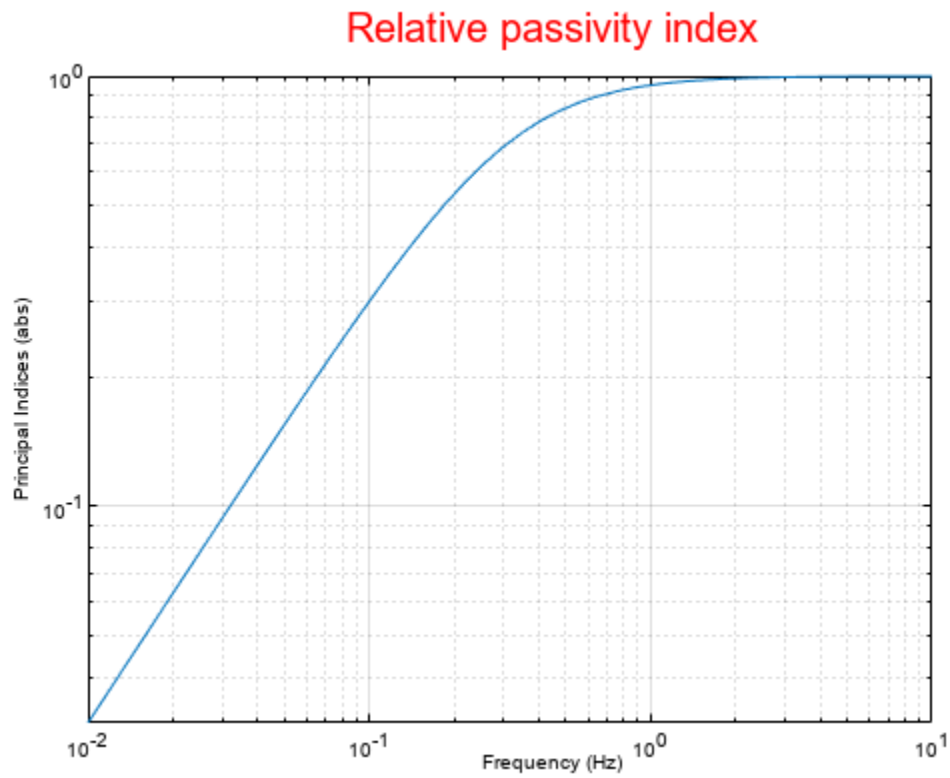

Because `plotoptions` begins with a fixed set of options, the plot result is independent of the toolbox preferences of the current MATLAB session.

Customized Sector Plot of Model with Complex Coefficients

For this example, create a relative sector plot of a model with complex coefficients. Then, turn the grid on, rename the plot, and change the frequency scale.

Create a state space model with complex data and specify a sector geometry.

```
A = [-3.50, -1.25-0.25i; 2, 0];
B = [1; 0];
C = [-0.75-0.5i, 0.625-0.125i];
D = 0.5;
Hc = [ss(A,B,C,D); 1];
Q = [1 0.1; 0.1 -1];
```

Create an options set based on the toolbox preferences.

```
plotoptions = sectorplotoptions('cstprefs');
plotoptions.Grid = 'on';
plotoptions.FreqScale = 'linear';
plotoptions.Title.String = 'Relative Sector Index Plot of Complex-Coefficient Model';
```

Now, create a sector plot with custom option set `plotoptions`.

```
sectorplot(Hc,Q,plotoptions)
```

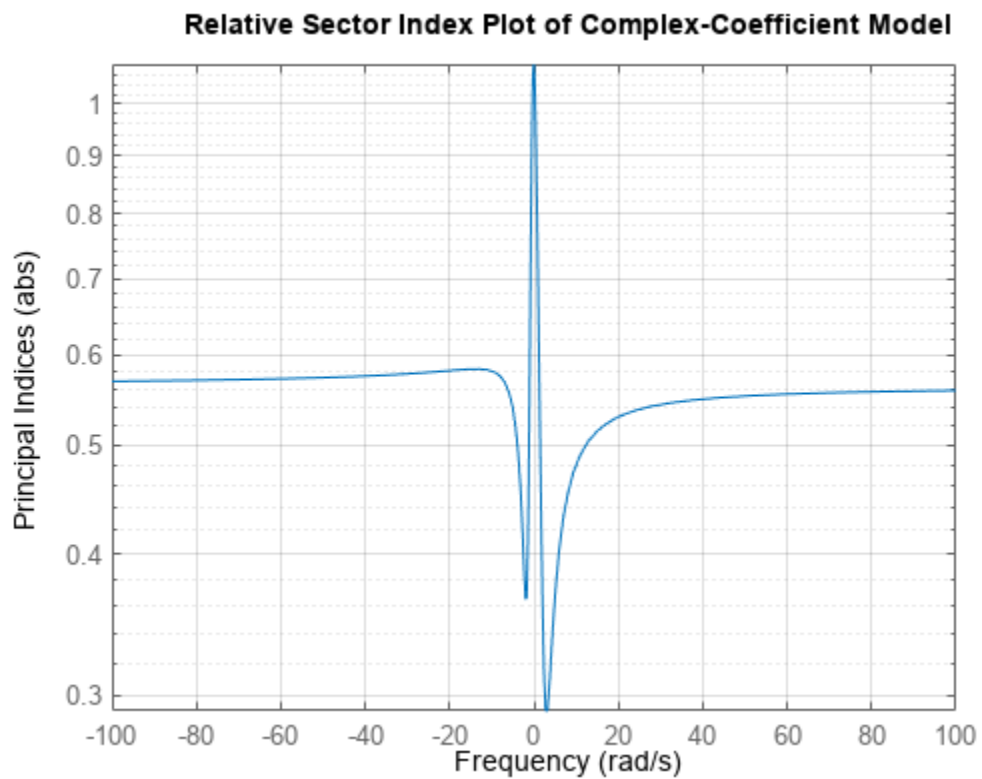

Version History

Introduced in R2016a

See Also

[passiveplot](#) | [sectorplot](#)

Topics

“Toolbox Preferences Editor”

series

Series connection of two models

Syntax

```
series
sys = series(sys1,sys2)
sys = series(sys1,sys2,outputs1,inputs2)
```

Description

`series` connects two model objects in series. This function accepts any type of model. The two systems must be either both continuous or both discrete with identical sample time. Static gains are neutral and can be specified as regular matrices.

`sys = series(sys1,sys2)` forms the basic series connection shown below.

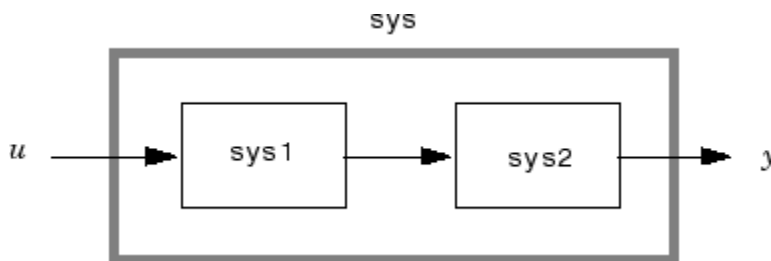

This command is equivalent to the direct multiplication

```
sys = sys2 * sys1
```

`sys = series(sys1,sys2,outputs1,inputs2)` forms the more general series connection.

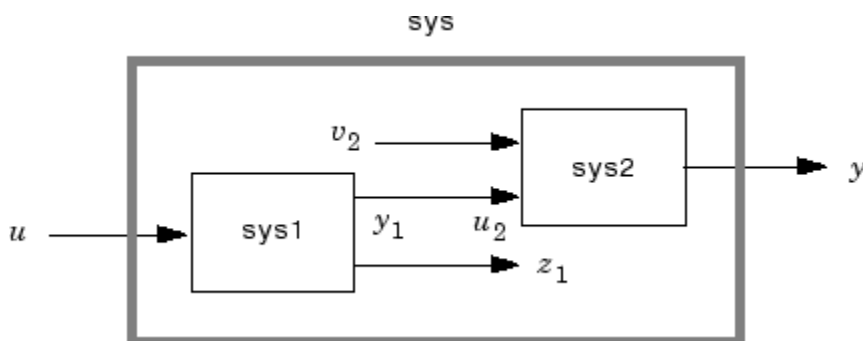

The index vectors `outputs1` and `inputs2` indicate which outputs y_1 of `sys1` and which inputs u_2 of `sys2` should be connected. The resulting model `sys` has u as input and y as output.

Examples

Consider a state-space system `sys1` with five inputs and four outputs and another system `sys2` with two inputs and three outputs. Connect the two systems in series by connecting outputs 2 and 4 of `sys1` with inputs 1 and 2 of `sys2`.

```
outputs1 = [2 4];  
inputs2 = [1 2];  
sys = series(sys1,sys2,outputs1,inputs2)
```

Version History

Introduced before R2006a

See Also

`append` | `feedback` | `parallel`

set

Set or modify model properties

Syntax

```
set(sys, 'Property', Value)
set(sys, 'Property1', Value1, 'Property2', Value2, ...)
sysnew = set( ___ )
set(sys, 'Property')
```

Description

`set` is used to set or modify the properties of a dynamic system model using property name/property value pairs.

`set(sys, 'Property', Value)` assigns the value `Value` to the property of the model `sys`. `'Property'` can be the full property name (for example, `'UserData'`) or any unambiguous case-insensitive abbreviation (for example, `'user'`). The specified property must be compatible with the model type. For example, if `sys` is a transfer function, `Variable` is a valid property but `StateName` is not. For a complete list of available system properties for any linear model type, see the reference page for that model type. This syntax is equivalent to `sys.Property = Value`.

`set(sys, 'Property1', Value1, 'Property2', Value2, ...)` sets multiple property values with a single statement. Each property name/property value pair updates one particular property.

`sysnew = set(___)` returns the modified dynamic system model, and can be used with any of the previous syntaxes.

`set(sys, 'Property')` displays help for the property specified by `'Property'`.

Examples

Specify Model Properties

Create a SISO state-space model with matrices A , B , C , and D equal to 1, 2, 3, and 4, respectively.

```
sys = ss(1,2,3,4);
```

Modify the properties of the model. Add an input delay of 0.1 second, label the input as `torque`, and set the D matrix to 0.

```
set(sys, 'InputDelay', 0.1, 'InputName', 'torque', 'D', 0);
```

View the model properties, and verify the changes.

```
get(sys)
```

```
A: 1
B: 2
C: 3
```

```

        D: 0
        E: []
        Scaled: 0
        StateName: {''}
        StatePath: {''}
        StateUnit: {''}
InternalDelay: [0x1 double]
        InputDelay: 0.1000
        OutputDelay: 0
        InputName: {'torque'}
        InputUnit: {''}
        InputGroup: [1x1 struct]
        OutputName: {''}
        OutputUnit: {''}
        OutputGroup: [1x1 struct]
        Notes: [0x1 string]
        UserData: []
        Name: ''
        Ts: 0
        TimeUnit: 'seconds'
SamplingGrid: [1x1 struct]

```

Tips

For discrete-time transfer functions, the convention used to represent the numerator and denominator depends on the choice of variable (see `tf` for details). Like `tf`, the syntax for `set` changes to remain consistent with the choice of variable. For example, if the `Variable` property is set to `'z'` (the default),

```
set(h, 'num', [1 2], 'den', [1 3 4])
```

produces the transfer function

$$h(z) = \frac{z + 2}{z^2 + 3z + 4}$$

However, if you change the `Variable` to `'z^-1'` by

```
set(h, 'Variable', 'z^-1'),
```

the same command

```
set(h, 'num', [1 2], 'den', [1 3 4])
```

now interprets the row vectors `[1 2]` and `[1 3 4]` as the polynomials $1 + 2z^{-1}$ and $1 + 3z^{-1} + 4z^{-2}$ and produces:

$$\bar{h}(z^{-1}) = \frac{1 + 2z^{-1}}{1 + 3z^{-1} + 4z^{-2}} = zh(z)$$

Note Because the resulting transfer functions are different, make sure to use the convention consistent with your choice of variable.

Version History

Introduced before R2006a

See Also

get | frd | ss | tf | zpk

Topics

“Store and Retrieve Model Data”

“What Are Model Objects?”

setDelayModel

Construct state-space model with internal delays

Syntax

```
sys = setDelayModel(H, tau)
sys = setDelayModel(A, B1, B2, C1, C2, D11, D12, D21, D22, tau)
```

Description

`sys = setDelayModel(H, tau)` constructs the state-space model `sys` obtained by LFT interconnection of the state-space model `H` with the vector of internal delays `tau`, as shown:

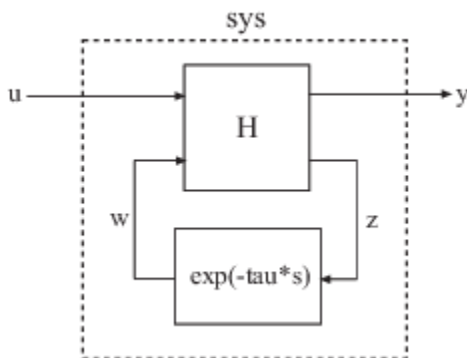

`sys = setDelayModel(A, B1, B2, C1, C2, D11, D12, D21, D22, tau)` constructs the state-space model `sys` described by the following equations:

$$\begin{aligned}\frac{dx(t)}{dt} &= Ax(t) + B_1u(t) + B_2w(t) \\ y(t) &= C_1x(t) + D_{11}u(t) + D_{12}w(t) \\ z(t) &= C_2x(t) + D_{21}u(t) + D_{22}w(t) \\ w(t) &= z(t - \tau).\end{aligned}$$

`tau` (τ) is the vector of internal delays in `sys`.

Input Arguments

H

State-space (ss) model to interconnect with internal delays `tau`.

tau

Vector of internal delays of `sys`.

For continuous-time models, express `tau` in seconds.

For discrete-time models, express `tau` as integer values that represent multiples of the sample time.

A, B1, B2, C1, C2, D11, D12, D21, D22

Set of state-space matrices that, with the internal delay vector `tau`, explicitly describe the state-space model `sys`.

Output Arguments**sys**

State-space (ss) model with internal delays `tau`.

Tips

- `setDelayModel` is an advanced operation and is not the natural way to construct models with internal delays. See “Time Delays in Linear Systems” for recommended ways of creating internal delays.
- The syntax `sys = setDelayModel(A, B1, B2, C1, C2, D11, D12, D21, D22, tau)` constructs a continuous-time model. You can construct the discrete-time model described by the state-space equations

$$x[k + 1] = Ax[k] + B_1u[k] + B_2w[k]$$

$$y[k] = C_1x[k] + D_{11}u[k] + D_{12}w[k]$$

$$z[k] = C_2x[k] + D_{21}u[k] + D_{22}w[k]$$

$$w[k] = z[k - \tau].$$

To do so, first construct `sys` using `sys = setDelayModel(A, B1, B2, C1, C2, D11, D12, D21, D22, tau)`. Then, use `sys.Ts` to set the sample time.

Version History

Introduced in R2007a

See Also

`getDelayModel` | `ss` | `lft`

Topics

“Internal Delays”

“Time Delays in Linear Systems”

setoptions

Package:

Set plot options handle or plot options property

Syntax

```
setoptions(h,p)
setoptions(h,'property1','value1',...,'propertyN','valueN')
setoptions(h,p,'property1','value1',...,'propertyN','valueN')
```

Description

You can use `setoptions` to set the plot handle options or properties list and use it to customize the plot, such as modify the axes labels, limits and units. For a list of the properties and values available for each plot type, see “Properties and Values Reference”. To customize an existing plot using the plot handle:

- 1 Obtain the plot handle
- 2 Use `getoptions` to obtain the option set
- 3 Update the plot using `setoptions` to modify the required options

For more information, see “Customizing Response Plots from the Command Line”.

`setoptions(h,p)` sets preferences for response plot using the plot handle `h` and plot options handle `p` that contains information about plot options.

`setoptions(h,'property1','value1',...,'propertyN','valueN')` assigns values to property-value pairs instead of using the plot options handle `p`. For a list of the properties and values available for each plot type, see “Properties and Values Reference”.

`setoptions(h,p,'property1','value1',...,'propertyN','valueN')` first assigns properties using the plot options handle `p`, and then overrides any properties governed by the specified property-value pairs.. For a list of the properties and values available for each plot type, see “Properties and Values Reference”.

Examples

Impulse Plot with Specified Grid Color

For this example, consider a MIMO state-space model with 3 inputs, 3 outputs and 3 states. Create a impulse plot with red colored grid lines.

Create the MIMO state-space model `sys_mimo`.

```
J = [8 -3 -3; -3 8 -3; -3 -3 8];
F = 0.2*eye(3);
A = -J\F;
B = inv(J);
```

```
C = eye(3);
D = 0;
sys_mimo = ss(A,B,C,D);
size(sys_mimo)
```

State-space model with 3 outputs, 3 inputs, and 3 states.

Create an impulse plot with plot handle `h` and use `getoptions` for a list of the options available.

```
h = impulseplot(sys_mimo)
```

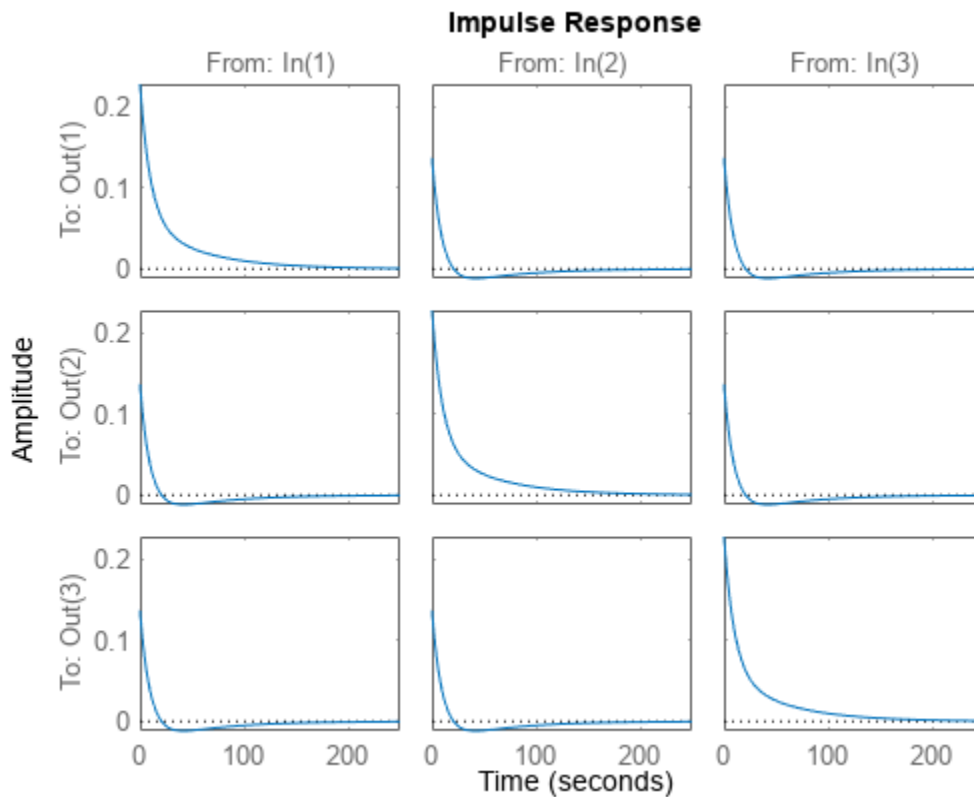

```
h =
```

```
respack.timeplot
```

```
p = getoptions(h)
```

```
p =
```

```

        Normalize: 'off'
    SettleTimeThreshold: 0.0200
        RiseTimeLimits: [0.1000 0.9000]
            TimeUnits: 'seconds'
ConfidenceRegionNumberSD: 1
        IOGrouping: 'none'
        InputLabels: [1x1 struct]
        OutputLabels: [1x1 struct]
        InputVisible: {3x1 cell}
```

```

OutputVisible: {3x1 cell}
Title: [1x1 struct]
XLabel: [1x1 struct]
YLabel: [1x1 struct]
TickLabel: [1x1 struct]
Grid: 'off'
GridColor: [0.1500 0.1500 0.1500]
XLim: {3x1 cell}
YLim: {3x1 cell}
XLimMode: {3x1 cell}
YLimMode: {3x1 cell}

```

Use `setoptions` to update the plot with the required customization.

```
setoptions(h, 'Grid', 'on', 'GridColor', [1 0 0]);
```

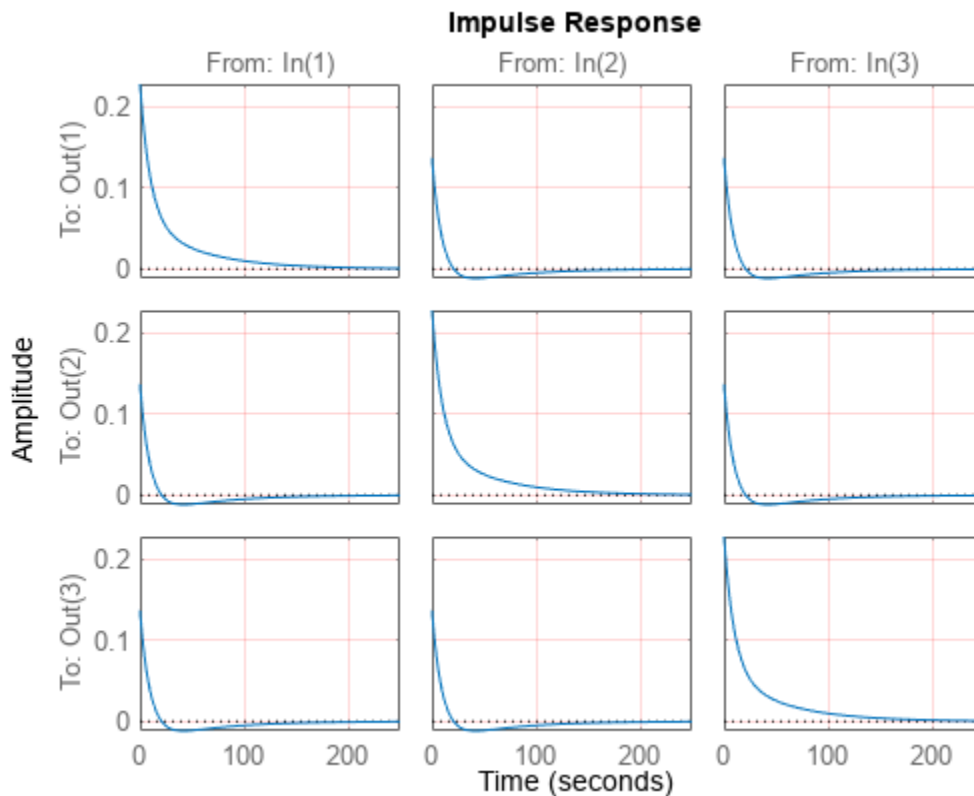

The impulse plot automatically updates when you call `setoptions`. For MIMO models, `impzplot` produces a grid of plots, each plot displaying the impulse response of one I/O pair.

Bode Plot with Specified Frequency Scale and Units

For this example, consider a MIMO state-space model with 3 inputs, 3 outputs and 3 states. Create a Bode plot with linear frequency scale, specify frequency units in Hz and turn the grid on.

Create the MIMO state-space model `sys_mimo`.

```
J = [8 -3 -3; -3 8 -3; -3 -3 8];
F = 0.2*eye(3);
A = -J\F;
B = inv(J);
C = eye(3);
D = 0;
sys_mimo = ss(A,B,C,D);
size(sys_mimo)
```

State-space model with 3 outputs, 3 inputs, and 3 states.

Create a Bode plot with plot handle `h` and use `getoptions` for a list of the options available.

```
h = bodeplot(sys_mimo);
p = getoptions(h)
```

`p =`

```

        FreqUnits: 'rad/s'
        FreqScale: 'log'
        MagUnits: 'dB'
        MagScale: 'linear'
        MagVisible: 'on'
MagLowerLimMode: 'auto'
        PhaseUnits: 'deg'
        PhaseVisible: 'on'
        PhaseWrapping: 'off'
        PhaseMatching: 'off'
PhaseMatchingFreq: 0
ConfidenceRegionNumberSD: 1
        MagLowerLim: 0
PhaseMatchingValue: 0
PhaseWrappingBranch: -180
        IOGrouping: 'none'
        InputLabels: [1x1 struct]
        OutputLabels: [1x1 struct]
        InputVisible: {3x1 cell}
        OutputVisible: {3x1 cell}
        Title: [1x1 struct]
        XLabel: [1x1 struct]
        YLabel: [1x1 struct]
        TickLabel: [1x1 struct]
        Grid: 'off'
        GridColor: [0.1500 0.1500 0.1500]
        XLim: {3x1 cell}
        YLim: {6x1 cell}
        XLimMode: {3x1 cell}
        YLimMode: {6x1 cell}
```

Use `setoptions` to update the plot with the requires customization.

```
setoptions(h, 'FreqScale', 'linear', 'FreqUnits', 'Hz', 'Grid', 'on');
```

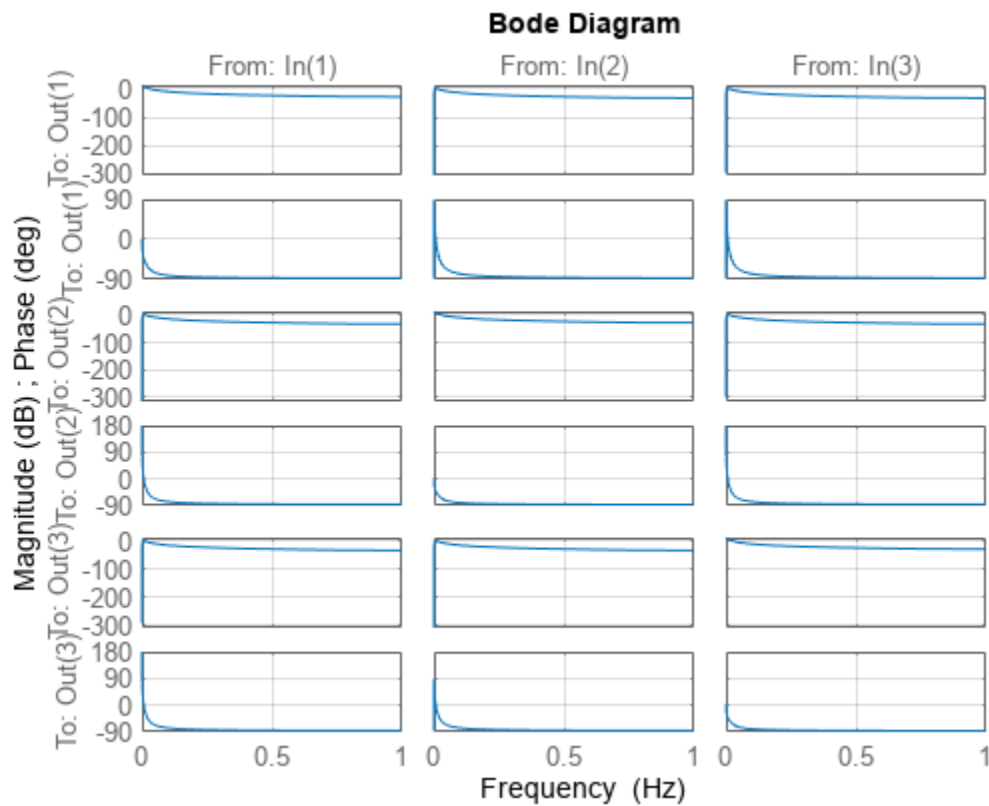

The Bode plot automatically updates when you call `setoptions`. For MIMO models, `bodeplot` produces an array of Bode plots, each plot displaying the frequency response of one I/O pair.

Change Frequency Units in Response Plot

Create the following continuous-time transfer function:

$$H(s) = \frac{1}{s+1}$$

```
sys = tf(1,[1 1]);
```

Create a Bode plot with plot handle `h`.

```
h = bodeplot(sys);
```

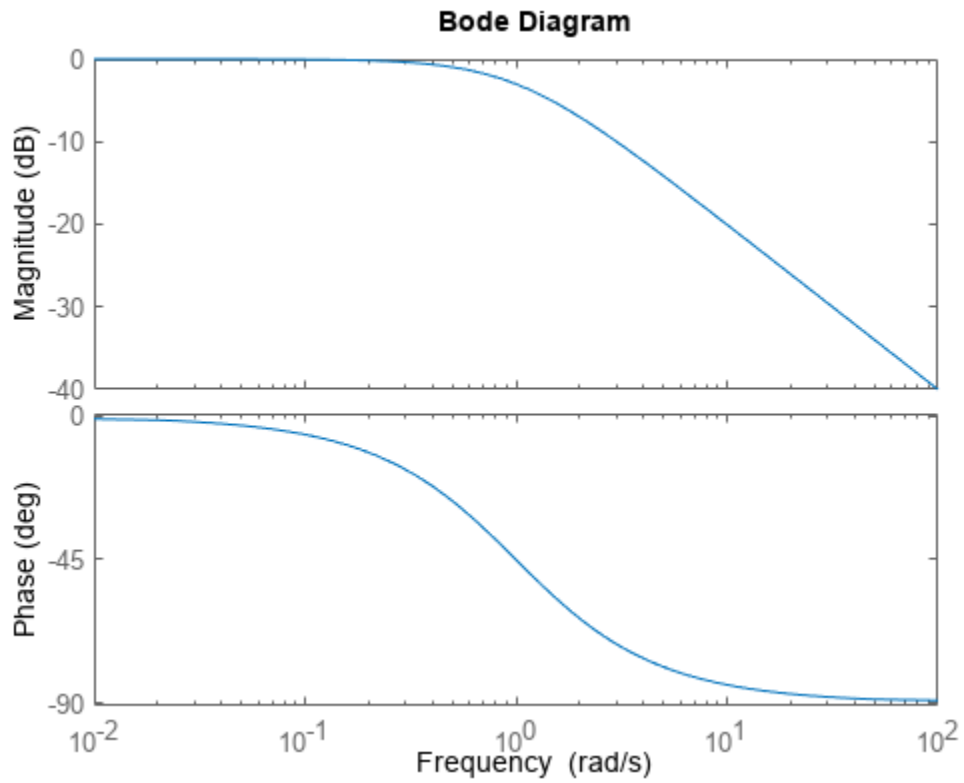

Create a plot options handle p.

```
p = getoptions(h);
```

Change frequency units of the plot to Hz.

```
p.FreqUnits = 'Hz';
```

Apply the plot options to the Bode plot.

```
setoptions(h,p);
```

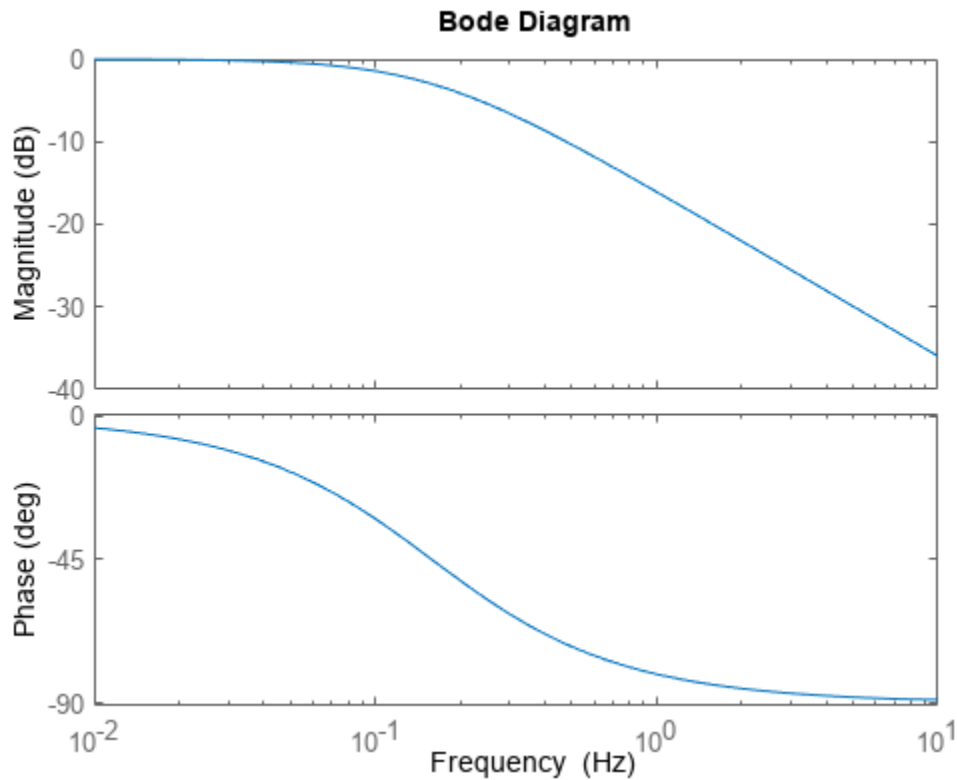

Alternatively, use `setoptions(h, 'FreqUnits', 'Hz')`.

Input Arguments

h — Plot handle

plot handle object

Plot handle, specified as a plot handle object. For example, `h` is a `mpzplot` object for a pole-zero or I/O pole-zero plot.

p — Plot options handle

plot options handle object

Plot options handle, specified as a plot options handle object. For example, `p` is a `PZMapOptions` object for a pole-zero or I/O pole-zero plot.

There are two ways to create a plot options handle:

- Use `getoptions`, which accepts a plot handle and returns a plot options handle.
 - `p = getoptions(h)`
- Create a default plot options handle using one of the following commands:
 - `bodeoptions` — Bode plot

- `hsvoptions` — Hankel singular values plot
- `nicholsoptions` — Nichols plot
- `nyquistoptions` — Nyquist plot
- `pzoptions` — Pole-zero plot
- `sigmaoptions` — Sigma plot
- `timeoptions` — Time plots (step, initial, impulse, etc.)

For example,

```
p = bodeoptions
```

returns a plot options handle for Bode plot.

Version History

Introduced before R2006a

See Also

`getoptions`

Topics

“Properties and Values Reference”

“Customizing Response Plots from the Command Line”

setBlockValue

Modify value of Control Design Block in Generalized Model

Syntax

`M = setBlockValue(M0,blockname,val)`

`M = setBlockValue(M0,blockvalues)`

`M = setBlockValue(M0,Mref)`

Description

`M = setBlockValue(M0,blockname,val)` modifies the current or nominal value of the Control Design Block `blockname` in the Generalized Model `M0` to the value specified by `val`.

`M = setBlockValue(M0,blockvalues)` modifies the value of several Control Design Blocks at once. The structure `blockvalues` specifies the blocks and replacement values. Blocks of `M0` not listed in `blockvalues` are unchanged.

`M = setBlockValue(M0,Mref)` takes replacement values from Control Design blocks in the Generalized Model `Mref`. This syntax modifies the Control Design Blocks in `M0` to match the current values of all corresponding blocks in `Mref`.

Use this syntax to propagate block values, such as tuned parameter values, from one parametric model to other models that depend on the same parameters.

Input Arguments

M0

Generalized Model containing the blocks whose current or nominal value is modified to `val`. For the syntax `M = setBlockValue(M0,Mref)` `M0` can be a single Control Design Block whose value is modified to match the value of the corresponding block in `Mref`.

blockname

Name of the Control Design Block in the model `M0` whose current or nominal value is modified.

To get a list of the Control Design Blocks in `M0`, enter `M0.Blocks`.

val

Replacement value for the current or nominal value of the Control Design Block, `blockname`. The value `val` can be any value that is compatible with `blockname` without changing the size, type, or sample time of `blockname`.

For example, you can set the value of a tunable PID block (`tunablePID`) to a pid controller model, or to a transfer function (`tf`) model that represents a PID controller.

blockvalues

Structure specifying Control Design Blocks of `M0` to modify, and the corresponding replacement values. The fields of the structure are the names of the blocks to modify. The value of each field specifies the replacement current or nominal value for the corresponding block.

Mref

Generalized Model that shares some Control Design Blocks with `M0`. The values of these blocks in `Mref` are used to update their counterparts in `M0`.

Output Arguments

M

Generalized Model obtained from `M0` by updating the values of the specified blocks.

Examples

Update Controller Model with Tuned Values

Propagate the values of tuned parameters to other Control Design Blocks.

You can use tuning commands such as `systemtune`, `looptune`, or the Robust Control Toolbox™ command `hinfstruct` to tune blocks in a closed-loop model of a control system. If you do so, the tuned controller parameters are embedded in a generalized model. You can use `setBlockValue` to propagate those parameters to a controller model.

Create a tunable model of the closed-loop response of a control system, and tune the parameters using `systemtune`.

```
s = tf('s');
num = 33000*(s^2 - 200*s + 90000);
den = (s + 12.5)*(s^2 + 25*s + 63000);
G = num/den;
```

```
C0 = tunablePID('C0','pi');
a = realp('a',1);
F0 = tf(a,[1 a]);
T0 = feedback(G*C0,F0);
T0.InputName = 'r';
T0.OutputName = 'y';
```

`T0` is a generalized model of the closed-loop control system and contains two tunable blocks:

- `C0` - Tunable PID controller
- `a` - Real tunable parameter

Create a tuning requirement for the output `y` to track the input `r`, and tune the system to meet that requirement.

```
Req = TuningGoal.Tracking('r','y',0.05);
[T,fSoft,~] = systemtune(T0,Req);
```

Final: Soft = 1.43, Hard = -Inf, Iterations = 59

The generalized model T contains the tuned values of C0 and a.

Propagate the tuned values of the controller in T to the controller model C0.

```
C = setBlockValue(C0,T)
```

```
C =  
Tunable continuous-time PID controller "C0" with formula:
```

$$K_p + K_i * \frac{1}{s}$$

and tunable parameters Kp, Ki.

Type "pid(C)" to see the current value and "get(C)" to see all properties.

C is still a tunablePID controller. The current PID gains in C are set to the values of the controller in T.

Obtain a numeric LTI model of the tuned controller using getValue.

```
CVal = getValue(C,T);
```

This command returns a numerical state-space model of the tuned controller.

Version History

Introduced in R2011b

See Also

[getValue](#) | [getBlockValue](#) | [showBlockValue](#) | [genss](#) | [systune](#) | [looptune](#) | [hinfstruct](#)

setData

Set values of tunable-surface coefficients

Syntax

```
Knew = setData(K,Kco)
Knew = setData(K,J,KcoJ)
```

Description

`Knew = setData(K,Kco)` sets the current values of the tunable coefficients of a tunable surface. `K` is a `tunableSurface` object that represents the parametric gain surface:

$$K(n(\sigma)) = \gamma[K_0 + K_1F_1(n(\sigma)) + \dots + K_MF_M(n(\sigma))],$$

where:

- σ is a vector of scheduling variables.
- $n(\sigma)$ is a normalization function (see the `Normalization` property of `tunableSurface`).
- γ is a scaling factor (see the `Normalization` property of `tunableSurface`).
- F_1, \dots, F_M are basis functions.
- K_0, \dots, K_M are tunable coefficients.

`Kco` is an array of new values for the coefficients $[K_0, \dots, K_M]$.

`Knew = setData(K,J,KcoJ)` sets the current value of the coefficient of the J th basis function F_J to `KcoJ`. Use $J = 0$ to set the constant coefficient K_0 .

Input Arguments

K — Gain surface

`tunableSurface` object

Gain surface, specified as a `tunableSurface` object.

Kco — New coefficient values

array

New coefficient values of the tunable surface, specified as an array.

If the tunable surface `K` is a scalar-valued gain, then the length of `K` is $(M+1)$, where M is the number of basis functions in the parameterization. For example, if `K` represents the tunable gain surface:

$$K(\alpha, V) = K_0 + K_1\alpha + K_2V + K_3\alpha V,$$

then `Kco` is the 1-by-4 vector $[K_0, K_1, K_2, K_3]$.

For array-valued gains, each coefficient expands to the I/O dimensions of the gain. These expanded coefficients are concatenated horizontally in `Kco`. (See `tunableSurface`.) For example, for a two-

input, two-output gain surface, K_{co} has dimensions $[2, 2(M+1)]$. See `evalSurf` for an example that uses `setData` on an array-valued gain.

J — Index of basis function

nonnegative integer

Index of basis function, specified as a nonnegative integer. To set the constant coefficient K_0 , use $J = 0$.

KcoJ — Coefficient of J th basis function

scalar | array

Coefficient of the J th basis function in the tunable surface parameterization, specified as a scalar or an array.

If the tunable surface K is a scalar-valued gain, then K_{coJ} is a scalar. If K is an array-valued gain, then K_{coJ} is an array that matches the I/O dimensions of the gain.

Output Arguments**Knew — Gain surface**

`tunableSurface` object

Gain surface with new coefficient values, returned as a `tunableSurface` object.

Version History

Introduced in R2015b

See Also

`tunableSurface` | `getData` | `evalSurf` | `viewSurf`

setValue

Modify current value of Control Design Block

Syntax

```
blk = setValue(blk0, val)
```

Description

`blk = setValue(blk0, val)` modifies the parameter values in the tunable Control Design Block, `blk0`, to best match the values specified by `val`. An exact match can only occur when `val` is compatible with the structure of `blk0`.

Input Arguments

blk0

Control Design Block whose value is modified.

val

Specifies the replacement parameters values for `blk0`. The value `val` can be any value that is compatible with `blk0` without changing the size, type, or sample time of `blk0`. For example, if `blk0` is a `tunablePID` block, valid types for `val` include `tunablePID`, a numeric `pid` controller model, or a numeric `tf` model that represents a PID controller. `setValue` uses the parameter values of `val` to set the current value of `blockname`.

Output Arguments

blk

Control Design Block of the same type as `blk0`, whose parameters are updated to best match the parameters of `val`.

Version History

Introduced in R2011b

See Also

`getValue` | `setBlockValue` | `getBlockValue`

sgrid

Generate s-plane grid of constant damping factors and natural frequencies

Syntax

```
sgrid
sgrid(zeta,wn)
sgrid( ____, 'new' )
sgrid(AX, ____)
```

Description

`sgrid` generates a grid of constant damping factors from 0 to 1 in steps of 0.1 and natural frequencies from 0 to 10 rad/sec in steps of one rad/sec for pole-zero and root locus plots. `sgrid` then plots the grid over the current axis. `sgrid` creates the grid over the plot if the current axis contains a continuous s-plane root locus diagram or pole-zero map.

`sgrid(zeta,wn)` plots a grid of constant damping factor and natural frequency lines for the damping factors and natural frequencies in the vectors `zeta` and `wn`, respectively. `sgrid(zeta,wn)` creates the grid over the plot if the current axis contains a continuous s-plane root locus diagram or pole-zero map.

Alternatively, you can select **Grid** from the context menu to generate the same s-plane grid.

`sgrid(____, 'new')` clears the current axes first and sets `hold` on.

`sgrid(AX, ____)` plots the s-plane grid on the `Axes` or `UIAxes` object in the current figure with the handle `AX`. Use this syntax when creating apps with `sgrid` in the App Designer.

Examples

Generate S-Plane Grid on Root Locus Plot

Create the following continuous-time transfer function:

$$H(s) = \frac{2s^2 + 5s + 1}{s^2 + 2s + 3}$$

```
H = tf([2 5 1],[1 2 3]);
```

Plot the root locus of the transfer function.

```
rlocus(H)
```

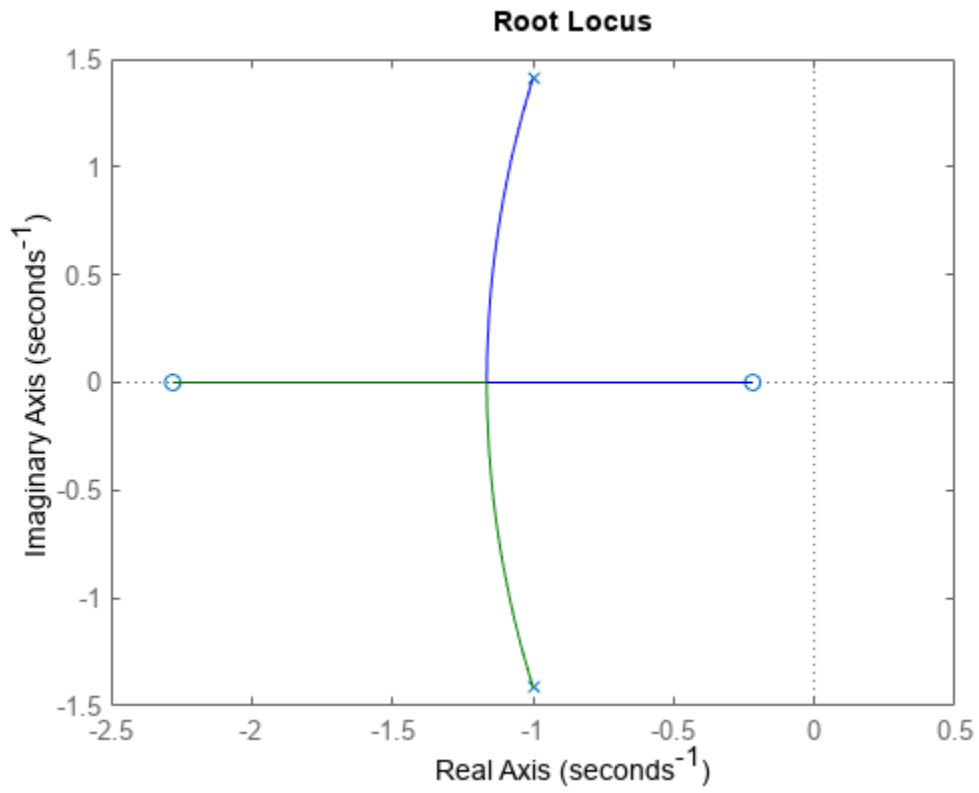

Plot s-plane grid lines on the root locus.

sgrid

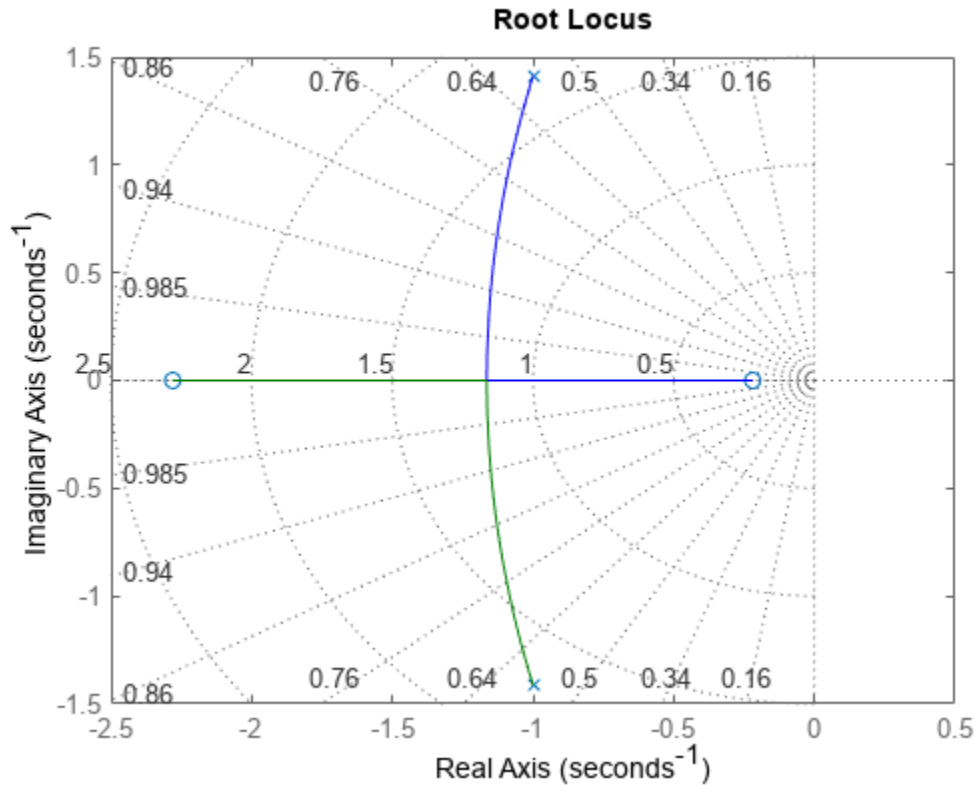

Input Arguments

zeta — Damping ratio

vector

Damping ratio, specified as a vector in the same order as `wn`.

wn — Normalized natural frequency

vector

Normalized natural frequency, specified as a vector.

AX — Object handle

Axes object | UIAxes object

Object handle, specified as an Axes or UIAxes object. Use AX to create apps with `sgrid` in the App Designer.

Version History

Introduced before R2006a

See Also

pzmap | rlocus | zgrid

showBlockValue

Display current value of Control Design Blocks in Generalized Model

Syntax

```
showBlockValue(M)
```

Description

`showBlockValue(M)` displays the current values of all Control Design Blocks in the Generalized Model, M. (For uncertain blocks, the “current value” is the nominal value of the block.)

Input Arguments

M

Generalized Model.

Examples

Create a tunable `genss` model, and display the current value of its tunable elements.

```
G = zpk([], [-1, -1], 1);
C = tunablePID('C', 'PID');
a = realp('a', 10);
F = tf(a, [1 a]);
T = feedback(G*C, 1)*F;
```

```
showBlockValue(T)
```

```
C =
Continuous-time I-only controller:
```

$$K_i * \frac{1}{s}$$

```
With Ki = 0.001
```

```
-----
a = 10
```

Tips

- Displaying the current values of a model is useful, for example, after you have tuned the free parameters of the model using a tuning command such as `systemtune`.
- `showBlockValue` displays the current values of all Control Design Blocks in a model, including tunable, uncertain, and switch blocks. To display the current values of only the tunable blocks, use `showTunable`.

Version History

Introduced in R2011b

See Also

genss | getBlockValue | setBlockValue | showTunable

showStateInfo

State vector map for sparse model

Syntax

```
showStateInfo(sys)
```

Description

`showStateInfo(sys)` prints a state vector map of the x or q vectors, that is, how they are partitioned into components, interfaces, and signals.

For `sparss` models, `showStateInfo` maps the content of the state vector x back to individual components and internal signals. Here, `Component` refers to the sub-components or sub-structures that were combined into `sys`. The `Signal` group includes all signals flowing between components, for example, in series or feedback connections.

For `mechss` models, `showStateInfo` maps the content of the vector q of generalized degrees of freedom in terms of components, interfaces, and signals. The `Interface` group includes all DAE variables arising from physical couplings between components (see `interface`).

Examples

Sparse Second-Order Model in a Feedback Loop

For this example, consider `sparseS0Signal.mat` that contains a sparse second-order model. Define an actuator, sensor, and controller and connect them together with the plant in a feedback loop.

Load the sparse matrices and create the `mechss` object.

```
load sparseS0Signal.mat
plant = mechss(M,C,K,B,F,[],[], 'Name', 'Plant');
```

Next, create an actuator and sensor using transfer functions.

```
act = tf(1,[1 0.5 3], 'Name', 'Actuator');
sen = tf(1,[0.02 7], 'Name', 'Sensor');
```

Create a PID controller object for the plant.

```
con = pid(1,1,0.1,0.01, 'Name', 'Controller');
```

Use the `feedback` command to connect the plant, sensor, actuator, and controller in a feedback loop.

```
sys = feedback(sen*plant*act*con,1)
```

Sparse continuous-time second-order model with 1 outputs, 1 inputs, and 7111 degrees of freedom.

Use `"spy"` and `"showStateInfo"` to inspect model structure.
Type `"properties('mechss')"` for a list of model properties.
Type `"help mechssOptions"` for available solver options for this model.

The resultant system `sys` is a `mechss` object since `mechss` objects take precedence over all other model object types.

Use `showStateInfo` to view the component and signal groups.

```
showStateInfo(sys)
```

The state groups are:

Type	Name	Size
Component	Sensor	1
Component	Plant	7102
Signal		1
Component	Actuator	2
Signal		1
Component	Controller	2
Signal		1
Signal		1

Use `xsort` to sort the components and signals, and then view the component and signal groups.

```
sysSort = xsort(sys);  
showStateInfo(sysSort)
```

The state groups are:

Type	Name	Size
Component	Sensor	1
Component	Plant	7102
Component	Actuator	2
Component	Controller	2
Signal		4

Observe that the components are now ordered before the signal partition. The signals are now sorted and grouped together in a single partition.

You can also visualize the sparsity pattern of the resultant system using `spy`.

```
spy(sysSort)
```

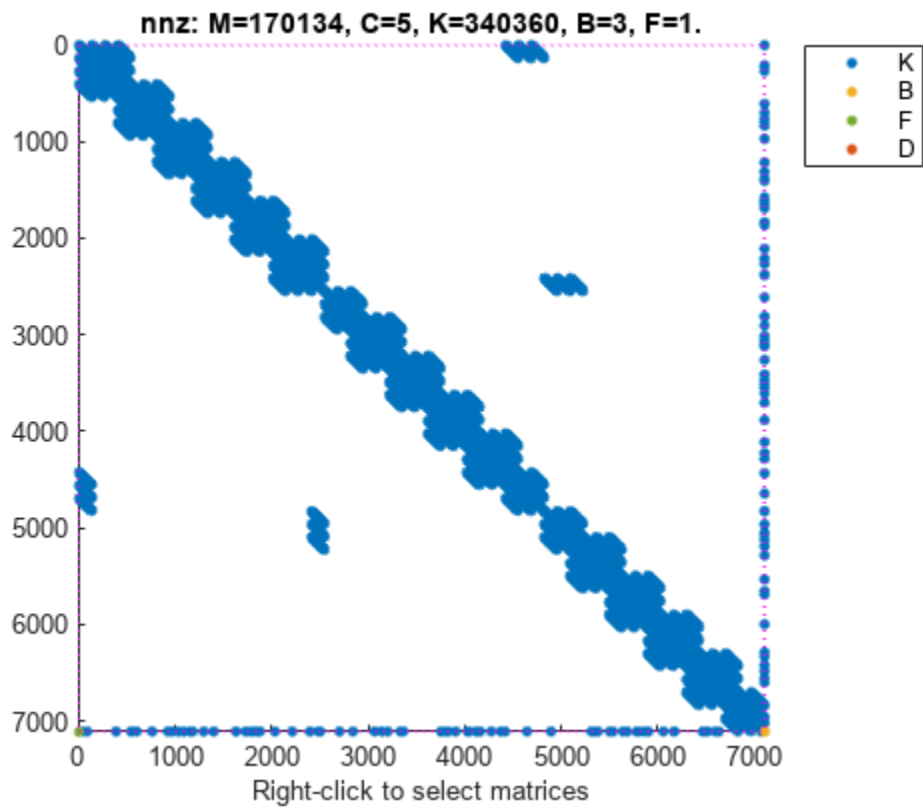

Physical Connections Between Components in Sparse Second-Order Model

For this example, consider a structural model that consists of two square plates connected with pillars at each vertex as depicted in the figure below. The lower plate is attached rigidly to the ground while the pillars are attached rigidly to each vertex of the square plate.

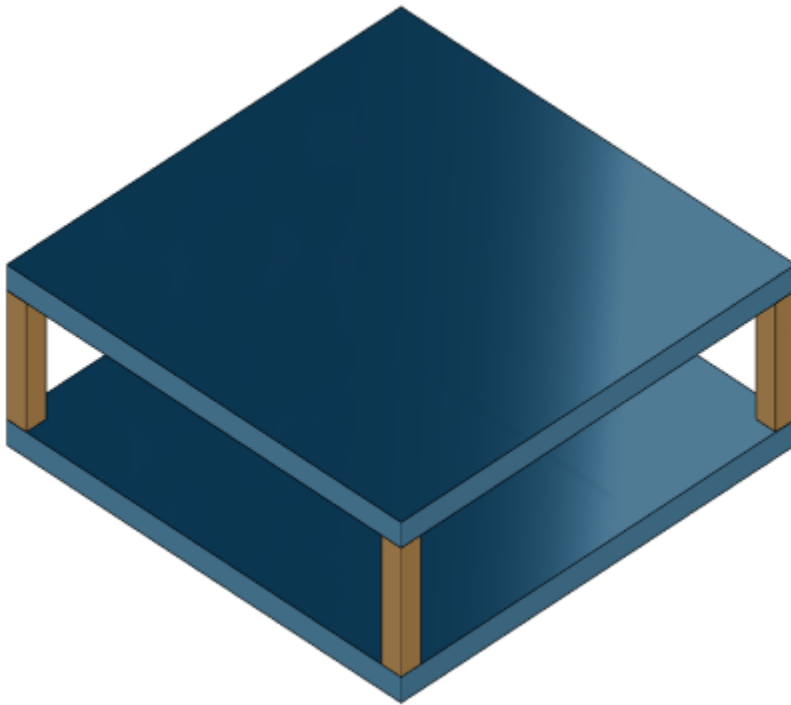

Load the finite element model matrices contained in `platePillarModel.mat` and create the sparse second-order model representing the above system.

```
load('platePillarModel.mat')
model = ...
    mechss(M1,[],K1,B1,F1,'Name','Plate1') + ...
    mechss(M2,[],K2,B2,F2,'Name','Plate2') + ...
    mechss(Mp,[],Kp,Bp,Fp,'Name','Pillar3') + ...
    mechss(Mp,[],Kp,Bp,Fp,'Name','Pillar4') + ...
    mechss(Mp,[],Kp,Bp,Fp,'Name','Pillar5') + ...
    mechss(Mp,[],Kp,Bp,Fp,'Name','Pillar6');
sys = model;
```

Use `showStateInfo` to examine the components of the `mechss` model object.

```
showStateInfo(sys)
```

The state groups are:

Type	Name	Size
Component	Plate1	2646
Component	Plate2	2646
Component	Pillar3	132
Component	Pillar4	132
Component	Pillar5	132
Component	Pillar6	132

Now, load the interfaced degree of freedom (DOF) index data from `dofData.mat` and use `interface` to create the physical connections between the two plates and the four pillars. `dofs` is a 6x7 cell array where the first two rows contain DOF index data for the first and second plates while the remaining four rows contain index data for the four pillars. By default, the function uses dual-assembly method of physical coupling.

```
load('dofData.mat','dofs')
for i=3:6
    sys = interface(sys,"Plate1",dofs{1,i},"Pillar"+i,dofs{i,1});
    sys = interface(sys,"Plate2",dofs{2,i},"Pillar"+i,dofs{i,2});
end
```

Specify connection between the bottom plate and the ground.

```
sysConDual = interface(sys,"Plate2",dofs{2,7});
```

Use `showStateInfo` to confirm the physical interfaces.

```
showStateInfo(sysConDual)
```

The state groups are:

Type	Name	Size
-----	-----	-----
Component	Plate1	2646
Component	Plate2	2646
Component	Pillar3	132
Component	Pillar4	132
Component	Pillar5	132
Component	Pillar6	132
Interface	Plate1-Pillar3	12
Interface	Plate2-Pillar3	12
Interface	Plate1-Pillar4	12
Interface	Plate2-Pillar4	12
Interface	Plate1-Pillar5	12
Interface	Plate2-Pillar5	12
Interface	Plate1-Pillar6	12
Interface	Plate2-Pillar6	12
Interface	Plate2-Ground	6

You can use `spy` to visualize the sparse matrices in the final model.

```
spy(sysConDual)
```

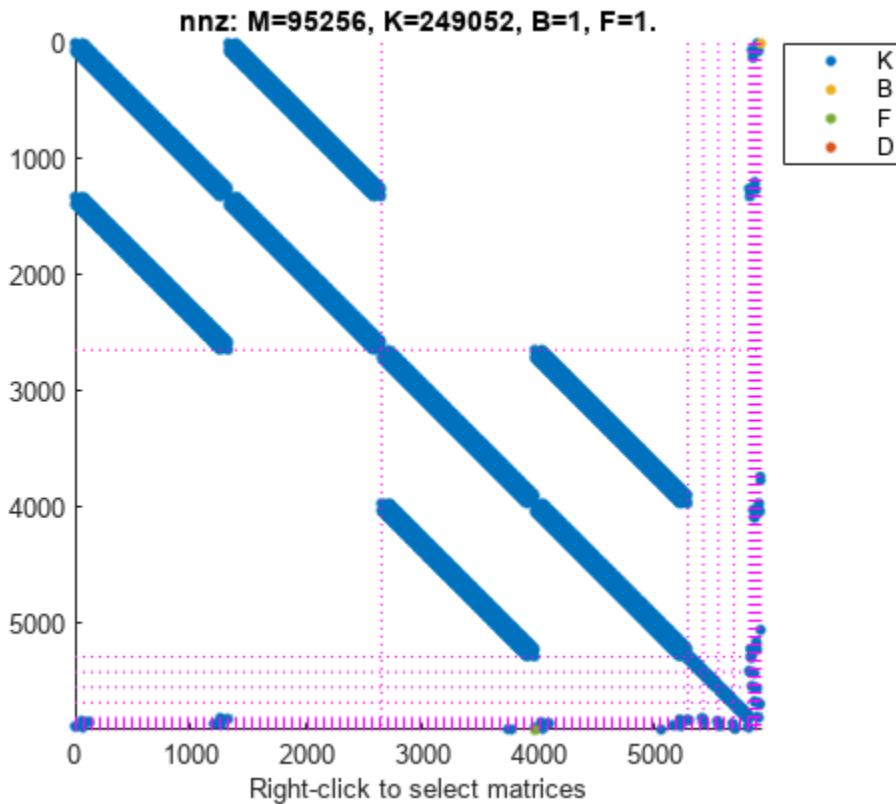

Now, specify physical connections using the primal-assembly method.

```
sys = model;
for i=3:6
    sys = interface(sys, "Plate1",dofs{1,i}, "Pillar"+i,dofs{i,1}, 'primal');
    sys = interface(sys, "Plate2",dofs{2,i}, "Pillar"+i,dofs{i,2}, 'primal');
end
sysConPrimal = interface(sys, "Plate2",dofs{2,7}, 'primal');
```

Use `showStateInfo` to confirm the physical interfaces.

```
showStateInfo(sysConPrimal)
```

The state groups are:

Type	Name	Size
Component	Plate1	2646
Component	Plate2	2640
Component	Pillar3	108
Component	Pillar4	108
Component	Pillar5	108
Component	Pillar6	108

Primal assembly eliminates half of the redundant DOFs associated with the shared set of DOFs in the global finite element mesh.

You can use `spy` to visualize the sparse matrices in the final model.

```
spy(sysConPrimal)
```

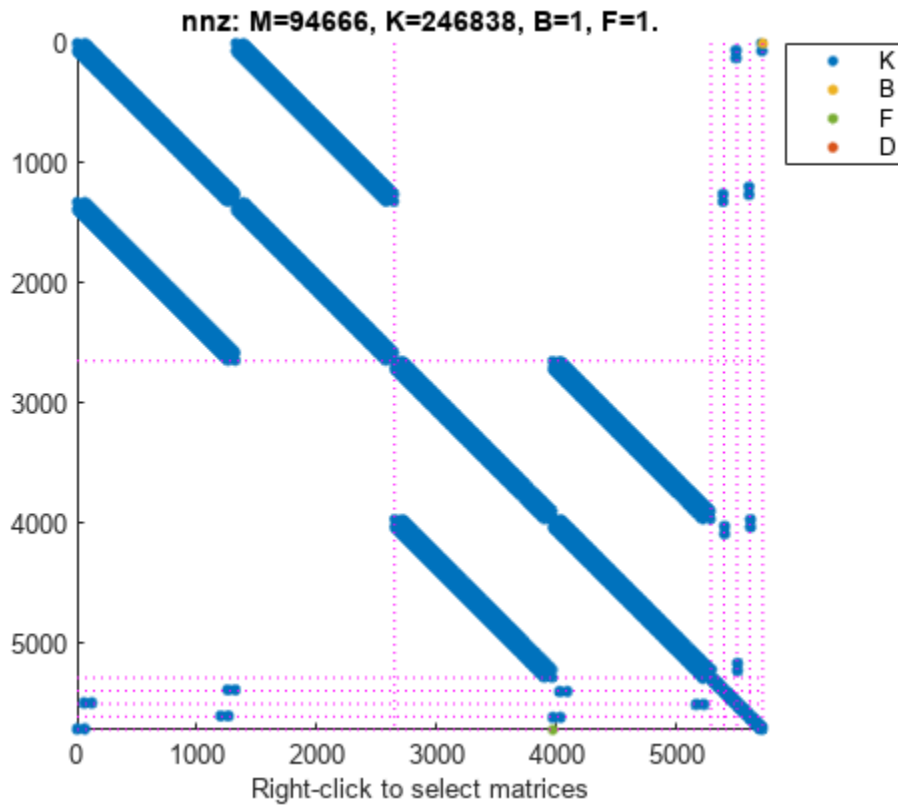

The data set for this example was provided by Victor Dolk from ASML.

Input Arguments

sys — Sparse state-space model

sparss model object | mechss model object

Sparse state-space model, specified as a sparss or mechss model object.

Version History

Introduced in R2020b

See Also

sparss | mechss | interface | xsort | spy

Topics

“Sparse Model Basics”

“Rigid Assembly of Model Components”

showTunable

Display current value of tunable Control Design Blocks in Generalized Model

Syntax

```
showTunable(M)
```

Description

`showTunable(M)` displays the current values of all tunable Control Design Blocks in a generalized LTI model. Tunable control design blocks are parametric blocks such as `realp`, `tunableTF`, and `tunablePID`.

Examples

Display Block Values of Tuned Control System Model

Tune the following control system using `systemtune`, and display the values of the tunable blocks.

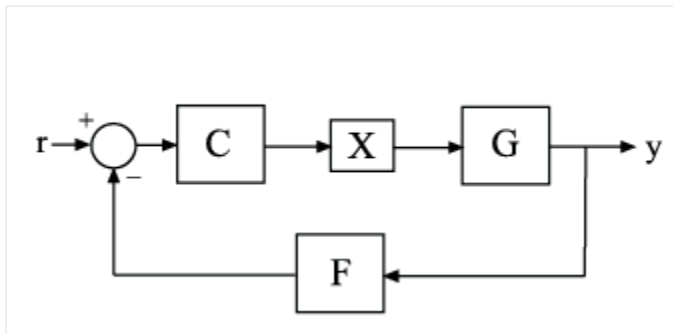

The control structure includes a PI controller `C` and a tunable low-pass filter in the feedback path. The plant `G` is a third-order system.

Create models of the system components and connect them together to create a tunable closed-loop model of the control system.

```
s = tf('s');
num = 33000*(s^2 - 200*s + 90000);
den = (s + 12.5)*(s^2 + 25*s + 63000);
G = num/den;
```

```
C0 = tunablePID('C','pi');
a = realp('a',1);
F0 = tf(a,[1 a]);
X = AnalysisPoint('X');
```

```
T0 = feedback(G*X*C0,F0);
T0.InputName = 'r';
T0.OutputName = 'y';
```

T0 is a `genss` model that has two tunable blocks, the PI controller, C, and the parameter, a. T0 also contains the switch block X.

Create a tuning requirement that forces the output y to track the input r, and tune the system to meet that requirement.

```
Req = TuningGoal.Tracking('r','y',0.05);
[T,fSoft,~] = systune(T0,Req);
```

```
Final: Soft = 1.43, Hard = -Inf, Iterations = 60
```

`systune` finds values for the tunable parameters that optimally meet the tracking requirement. The output T is a `genss` model with the same Control Design Blocks as T0. The current values of those blocks are the tuned values.

Examine the tuned values of the tunable blocks of the control system.

```
showTunable(T)
```

```
C =
```

$$K_p + K_i * \frac{1}{s}$$

```
with Kp = 0.000433, Ki = 0.00525
```

```
Name: C
```

```
Continuous-time PI controller in parallel form.
```

```
-----
a = 67.8
```

`showTunable` displays the values of the tunable blocks only. If you use `showBlockValue` instead, the display also includes the switch block X.

Input Arguments

M — Input model

generalized LTI model

Input model of which to display tunable block values, specified as a generalized LTI model such as a `genss` model.

Tips

- Displaying the current values of tunable blocks is useful, for example, after you have tuned the free parameters of the model using a tuning command such as `systune`.
- `showTunable` displays the current values of the tunable blocks only. To display the current values of all Control Design Blocks in a model, including tunable, uncertain, and switch blocks, use `showBlockValue`.

Version History

Introduced in R2012b

See Also

genss | getBlockValue | setBlockValue | showBlockValue | systune

Topics

“Generalized Models”

“Control Design Blocks”

sigma

Singular value plot of dynamic system

Syntax

```
sigma(sys)
sigma(sys1,sys2,...,sysN)
sigma(sys1,LineStyle1,...,sysN,LineStyleN)
sigma( __ ,w)
sigma( __ ,type)
```

```
[sv,wout] = sigma(sys)
[sv,wout] = sigma(sys,w)
```

Description

`sigma(sys)` plots the singular values of the frequency response of a dynamic system model `sys`. `sigma` automatically determines frequencies to plot based on system dynamics.

If `sys` is a single-input, single-output (SISO) model, then the singular value plot is similar to its Bode magnitude response.

If `sys` is a multi-input, multi-output (MIMO) model with `Nu` inputs and `Ny` outputs, then the singular value plot shows $\min(Nu, Ny)$ lines on the plot corresponding to each singular value of the frequency response matrix. For MIMO systems, the singular value plot extends the Bode magnitude response and is useful in robustness analysis.

If `sys` is a model with complex coefficients, then in:

- Log frequency scale, the plot shows two branches, one for positive frequencies and one for negative frequencies. The plot also shows arrows to indicate the direction of increasing frequency values for each branch. See “Singular Value Plot of Model with Complex Coefficients” on page 2-1166.
- Linear frequency scale, the plot shows a single branch with a symmetric frequency range centered at a frequency value of zero.

`sigma(sys1,sys2,...,sysN)` plots the singular values of response of multiple dynamic systems on the same plot. All systems must have the same number of inputs and outputs.

`sigma(sys1,LineStyle1,...,sysN,LineStyleN)` specifies a color, line style, and marker for each system in the plot.

`sigma(__ ,w)` plots singular values of the system response for frequencies specified by `w`.

- If `w` is a cell array of the form `{wmin,wmax}`, then `sigma` plots the response at frequencies ranging between `wmin` and `wmax`.
- If `w` is a vector of frequencies, then `sigma` plots the response at each specified frequency. The vector `w` can contain both negative and positive frequencies.

You can use `w` with any of the input-argument combinations in previous syntaxes.

`sigma(____, type)` plots the modified singular value responses based on the `type` argument. Specify `type` as:

- 1 to plot the singular values of the frequency response H^{-1} , where H is the frequency response of `sys`.
- 2 to plot the singular values of the frequency response $I+H$.
- 3 to plot the singular values of the frequency response $I+H^{-1}$.

You can only use the `type` argument for *square systems*, that is, systems that have the same number of inputs and outputs.

`[sv, wout] = sigma(sys)` returns the singular values of the response at each frequency in the vector `wout`. The output `sv` is a matrix, and the value `sv(:, k)` gives the singular values in descending order at the frequency `wout(k)`. The function automatically determines frequencies in `wout` based on system dynamics. This syntax does not draw a plot.

`[sv, wout] = sigma(sys, w)` returns the singular values `sv` at the frequencies specified by `w`.

- If `w` is a cell array of the form `{wmin, wmax}`, then `wout` contains frequencies ranging between `wmin` and `wmax`.
- If `w` is a vector of frequencies, then `wout = w`.

Examples

Singular Value Plot of Dynamic System

Create a singular value plot of the following continuous-time SISO dynamic system.

$$H(s) = \frac{s^2 + 0.1s + 7.5}{s^4 + 0.12s^3 + 9s^2}$$

```
H = tf([1 0.1 7.5],[1 0.12 9 0 0]);  
sigma(H)
```

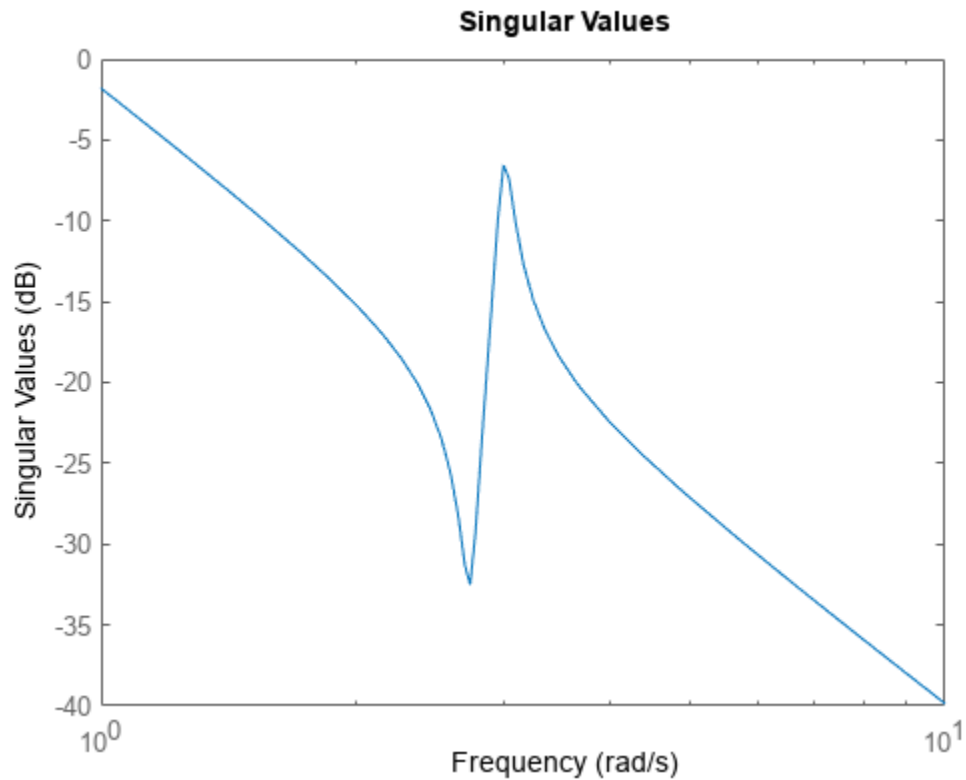



sigma automatically selects the plot range based on the system dynamics.

Sigma Plot at Specified Frequencies

Create a singular value plot over a specified frequency range. Use this approach when you want to focus on the dynamics in a particular range of frequencies.

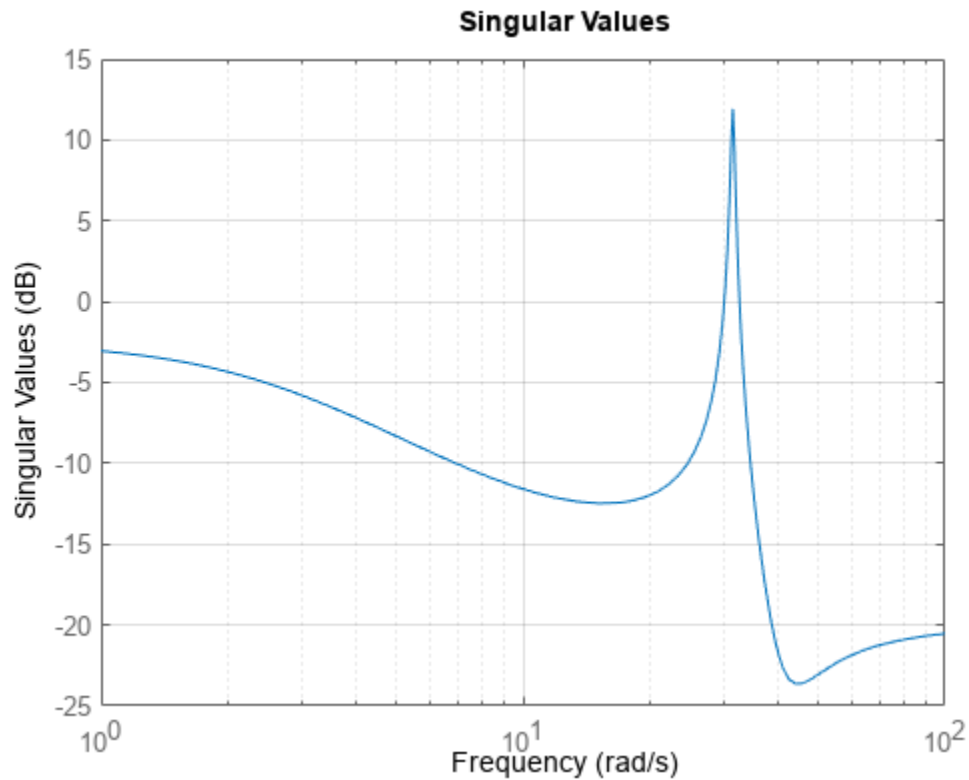
```
H = tf([-0.1, -2.4, -181, -1950], [1, 3.3, 990, 2600]);  
sigma(H, {1, 100})  
grid on
```



The cell array `{1, 100}` specifies the minimum and maximum frequency values in the plot. When you provide frequency bounds in this way, the function selects intermediate points for frequency response data.

Alternatively, specify a vector of frequency points to use for evaluating and plotting the frequency response.

```
w = [1 5 10 15 20 23 31 40 44 50 85 100];  
sigma(H,w, '-.-')  
grid on
```

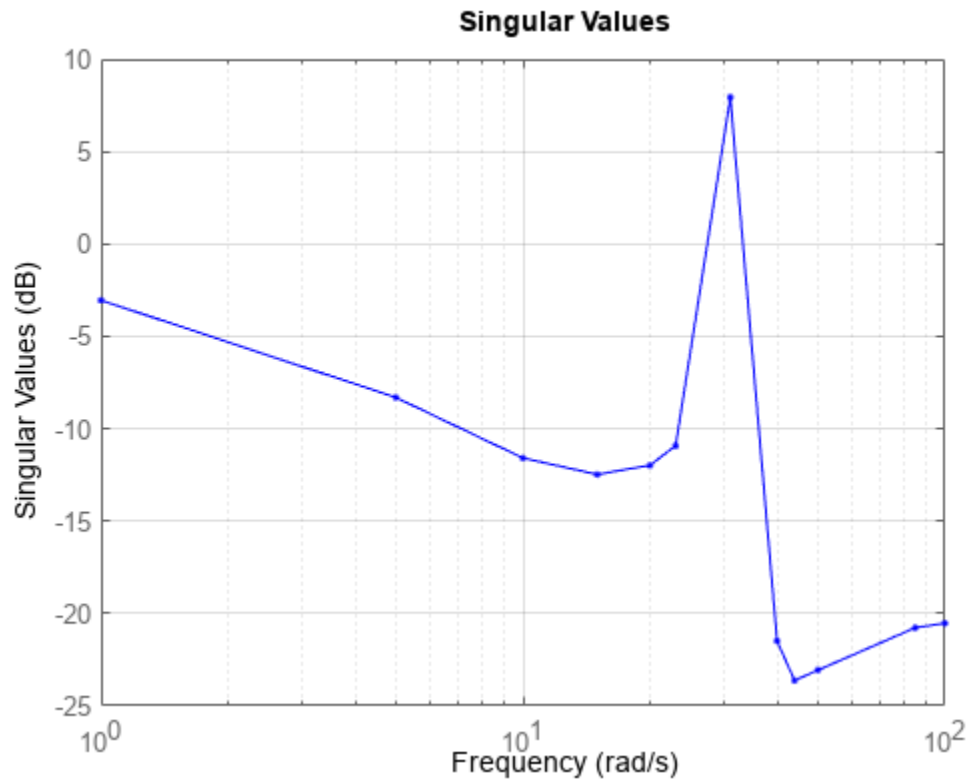

sigma plots the frequency response at the specified frequencies only.

Compare Singular Value Plots of Several Dynamic Systems

Compare the frequency response of a continuous-time system to an equivalent discretized system on the same singular value plot.

Create continuous-time and discrete-time dynamic systems.

```
H = tf([1 0.1 7.5],[1 0.12 9 0 0]);
Hd = c2d(H,0.5,'zoh');
```

Create a plot that displays both systems.

```
sigma(H,Hd)
```

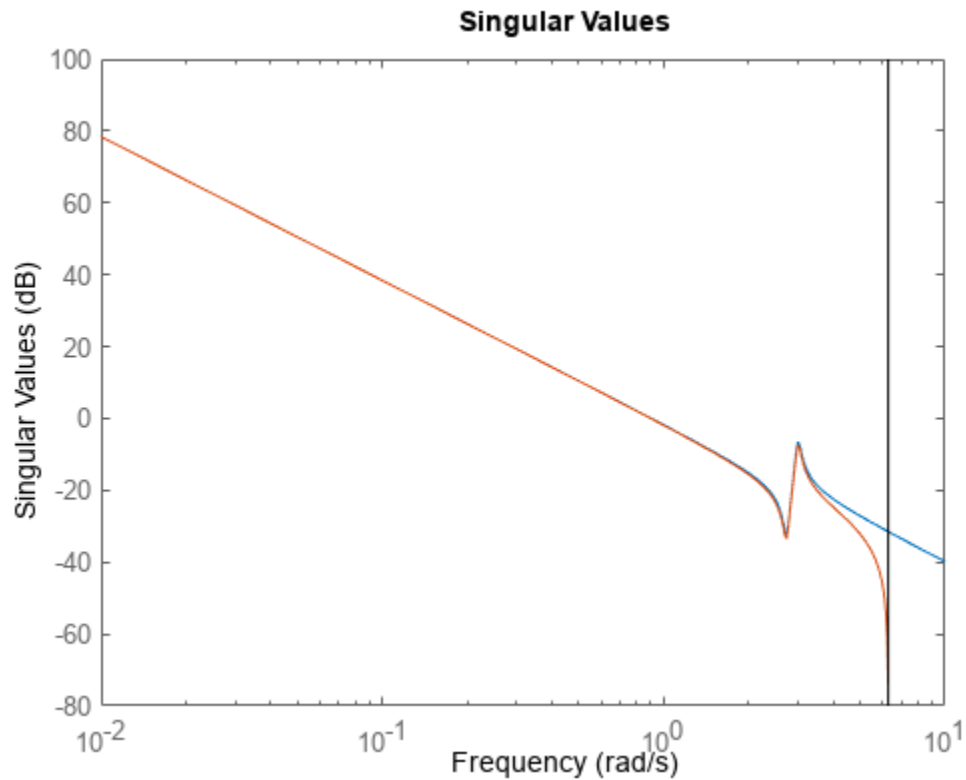

The `sigma` plot of a discrete-time system includes a vertical line marking the Nyquist frequency of the system.

Singular Value Plot with Specified Line Attributes

Specify the line style, color, or marker for each system in a `sigma` plot using the `LineStyle` input argument.

```
H = tf([1 0.1 7.5],[1 0.12 9 0 0]);  
Hd = c2d(H,0.5,'zoh');  
sigma(H,'r',Hd,'b--')
```

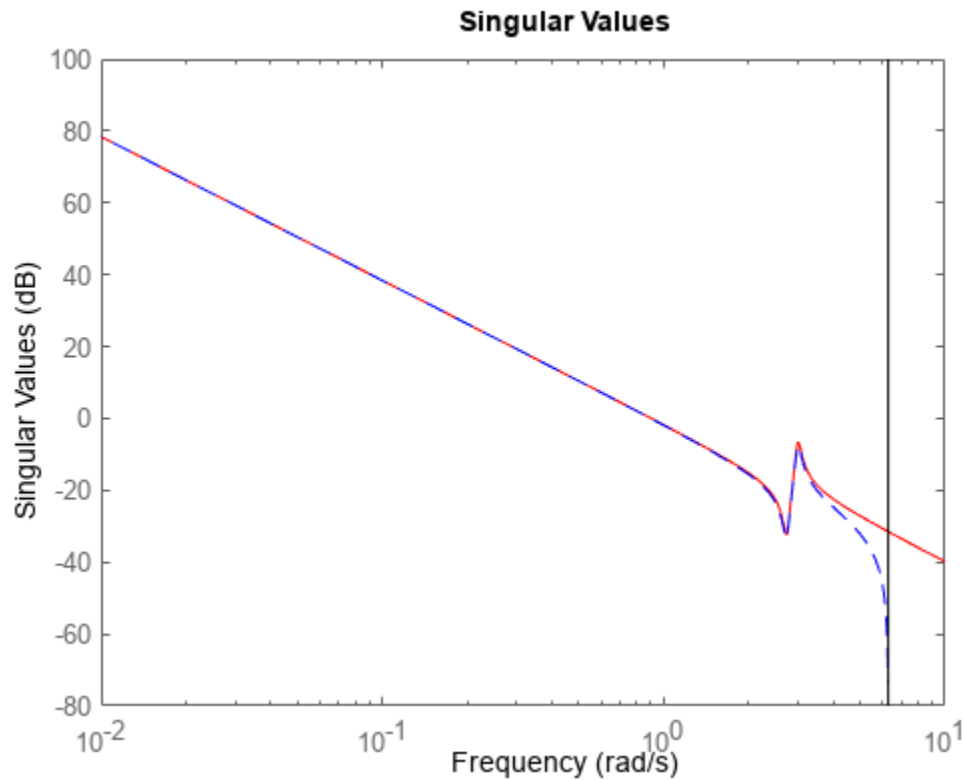

The first `LineStyle`, 'r', specifies a solid red line for the response of `H`. The second `LineStyle`, 'b--', specifies a dashed blue line for the response of `Hd`.

Obtain Singular Value Data

Compute the singular values of the frequency response of a SISO system.

If you do not specify frequencies, `sigma` chooses frequencies based on the system dynamics and returns them in the second output argument.

```
H = tf([1 0.1 7.5],[1 0.12 9 0 0]);
[sv,wout] = sigma(H);
```

Because `H` is a SISO model, the first dimension of `sv` is 1. The second dimension is the number of frequencies in `wout`.

```
size(sv)
```

```
ans = 1×2
```

```
1 40
```

```
length(wout)
```

```
ans = 40
```

Thus, each entry along the second dimension of `sv` gives the singular value of the response at the corresponding frequency in `wout`.

Singular Values of MIMO System

For this example, create a 2-output, 3-input system.

```
rng(0, 'twister'); % For reproducibility
H = rss(4,2,3);
```

For this system, `sigma` plots the singular values of the frequency response matrix in the same plot.

```
sigma(H)
```

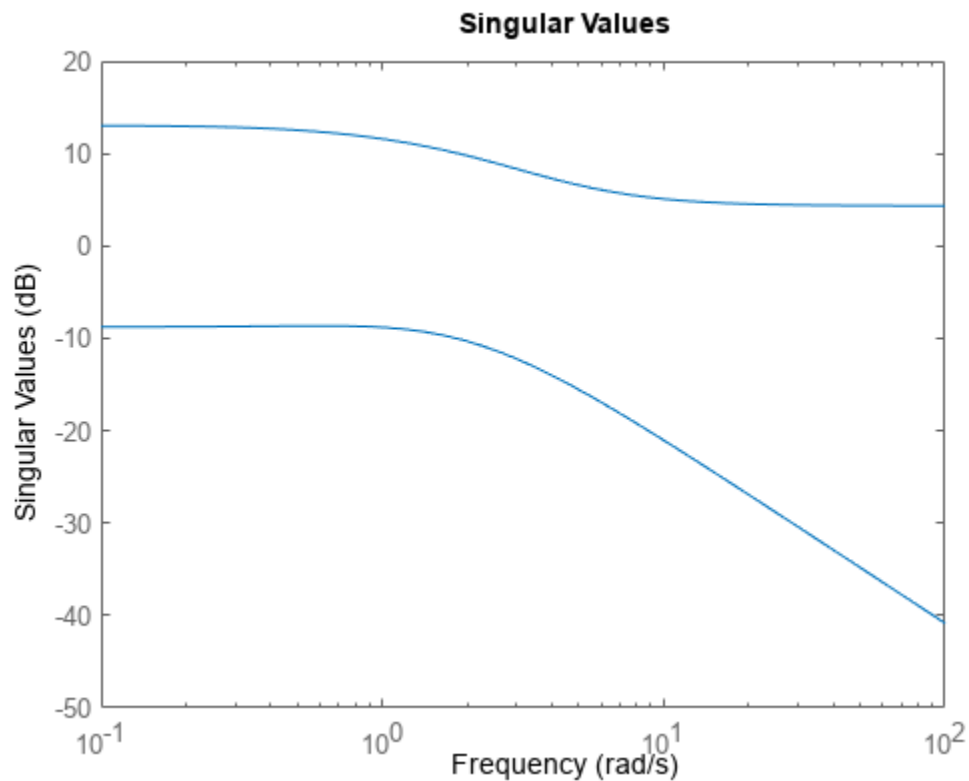

Compute the singular values at 20 frequencies between 1 and 10 radians.

```
w = logspace(0, 1, 20);
sv = sigma(H, w);
```

`sv` is a matrix, in which the rows correspond to the singular values of the frequency response matrix and the columns are the frequency values. Examine the dimensions.

```
size(sv)
```

```
ans = 1x2
      2    20
```

Thus, for example, $sv(:, 10)$ are the singular values of the response computed at the 10th frequency in w .

Compute and Plot Singular Values

Consider the following two-input, two-output dynamic system.

$$H(s) = \begin{bmatrix} 0 & \frac{3s}{s^2 + s + 10} \\ \frac{s+1}{s+5} & \frac{2}{s+6} \end{bmatrix}.$$

Compute the singular value responses of $H(s)$ and $I + H(s)$.

```
H = [0, tf([3 0],[1 1 10]) ; tf([1 1],[1 5]), tf(2,[1 6])];
[svH,wH] = sigma(H);
[svIH,wIH] = sigma(H,[],2);
```

In the last command, the input 2 selects the second response type, $I + H(s)$. The vectors svH and $svIH$ contain the singular value response data, at the frequencies in wH and wIH .

Plot the singular value responses of both systems.

```
subplot(211)
sigma(H)
subplot(212)
sigma(H,[],2)
```

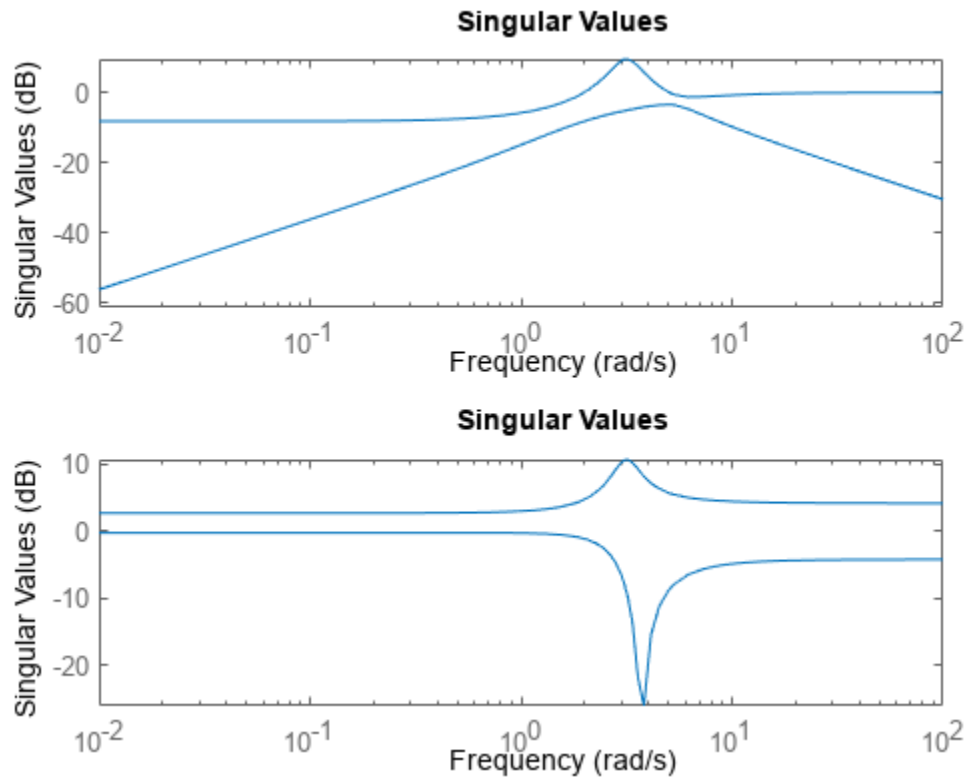

Singular Value Plot of Model with Complex Coefficients

Create a singular value plot of a model with complex coefficients and a model with real coefficients on the same plot.

```
rng(0)
A = [-3.50, -1.25-0.25i; 2, 0];
B = [1; 0];
C = [-0.75-0.5i, 0.625-0.125i];
D = 0.5;
Gc = ss(A,B,C,D);
Gr = rss(4);
sigma(Gc,Gr)
legend('Complex-coefficient model', 'Real-coefficient model')
```

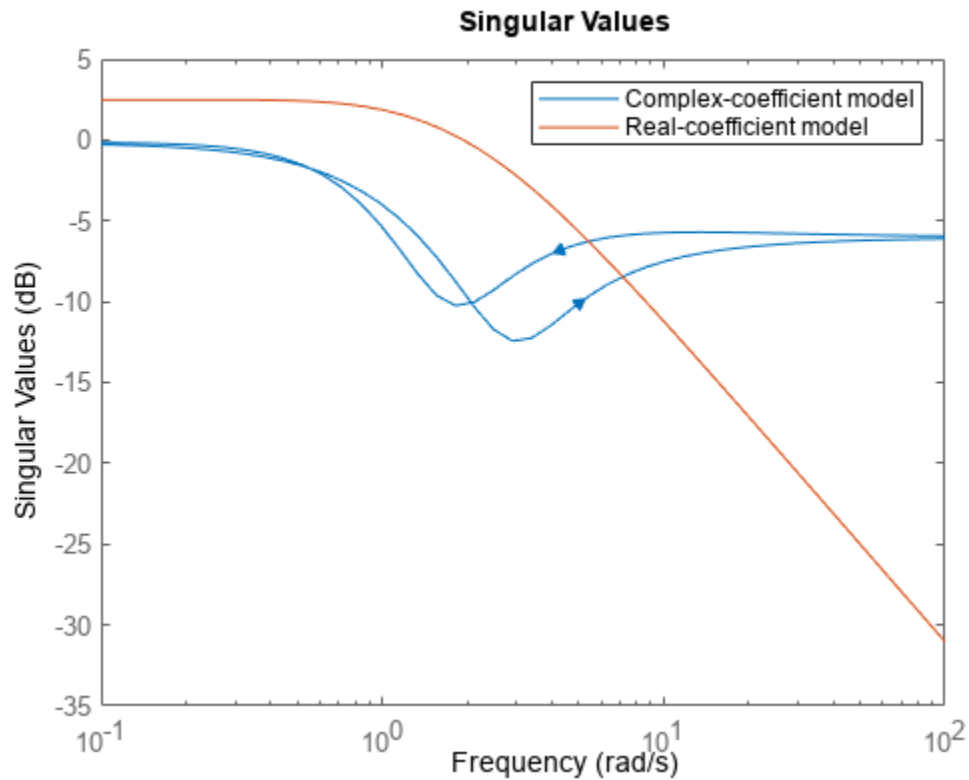
In log frequency scale, the plot shows two branches for models with complex coefficients, one for positive frequencies, with a right-pointing arrow, and one for negative frequencies, with a left-pointing arrow. In both branches, the arrows indicate the direction of increasing frequencies. The plots for models with real coefficients always contain a single branch with no arrows.

You can change the frequency scale of the plot by right-clicking the plot and selecting **Properties**. In the Property Editor dialog, on the **Units** tab, set the frequency scale to `linear` scale. Alternatively, you can use the `sigmaplot` function with a `sigmaoptions` object to create a customized plot.

```
opt = sigmaoptions;
opt.FreqScale = 'Linear';
```

Create the plot with customized options.

```
sigmaplot(Gc,Gr,opt)
legend('Complex-coefficient model','Real-coefficient model')
```

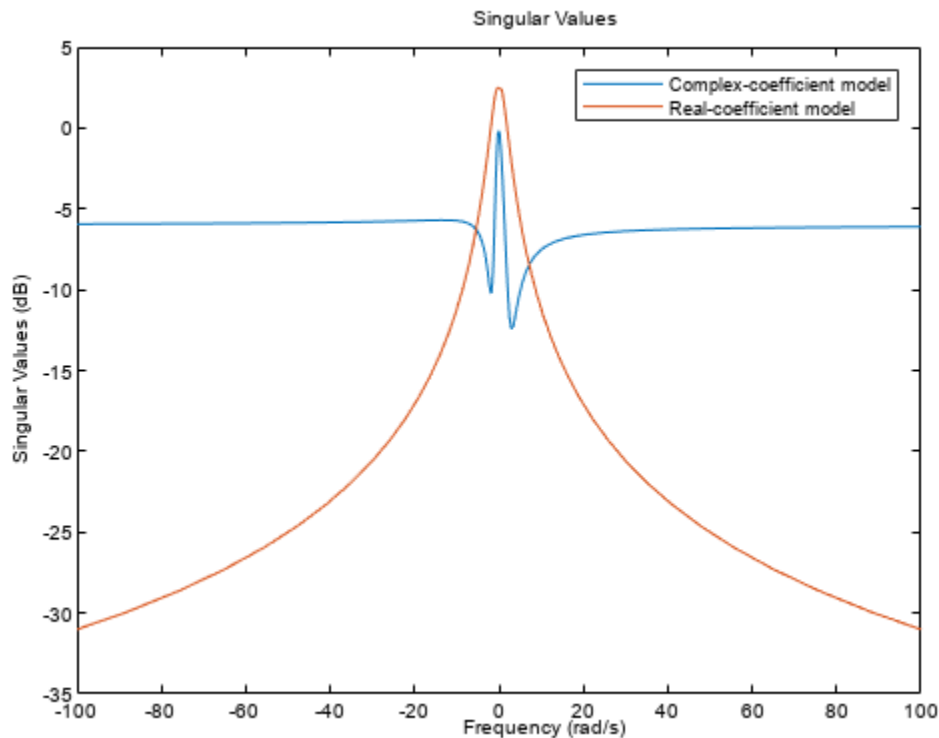

In linear frequency scale, the plot shows a single branch with a symmetric frequency range centered at a frequency value of zero. The plot also shows the negative-frequency response of a model with real coefficients when you plot the response along with a model with complex coefficients.

Input Arguments

sys — Dynamic system

dynamic system model | model array

Dynamic system, specified as a SISO or MIMO dynamic system model or an array of dynamic system models. Dynamic systems that you can use include:

- Continuous-time or discrete-time numeric LTI models, such as `tf`, `zpk`, or `ss` models.
- Generalized or uncertain LTI models such as `genss` or `uss` models. (Using uncertain models requires Robust Control Toolbox software.)
 - For tunable control design blocks, the function evaluates the model at its current value for both plotting and returning frequency response data.
 - For uncertain control design blocks, the function plots the nominal value and random samples of the model. When you use output arguments, the function returns frequency response data for the nominal model only.
- Frequency-response data models such as `frd` models. For such models, the function plots the response at frequencies defined in the model.

- Identified LTI models, such as `idtf`, `idss`, or `idproc` models. Using identified models requires System Identification Toolbox software.

If `sys` is an array of models, the function plots the frequency responses of all models in the array on the same axes.

LineStyle — Line style, marker, and color

character vector | string

Line style, marker, and color, specified as a string or vector of one, two, or three characters. The characters can appear in any order. You do not need to specify all three characteristics (line style, marker, and color). For example, if you omit the line style and specify the marker, then the plot shows only the marker and no line. For more information about configuring this argument, see the `LineStyle` input argument of the `plot` function.

Example: `'r--'` specifies a red dashed line

Example: `'*b'` specifies blue asterisk markers

Example: `'y'` specifies a yellow line

w — Frequencies

{`wmin`,`wmax`} | vector

Frequencies at which to compute and plot frequency response, specified as the cell array `{wmin,wmax}` or as a vector of frequency values.

- If `w` is a cell array of the form `{wmin,wmax}`, then the function computes the response at frequencies ranging between `wmin` and `wmax`.
- If `w` is a vector of frequencies, then the function computes the response at each specified frequency. For example, use `logspace` to generate a row vector with logarithmically spaced frequency values. The vector `w` can contain both positive and negative frequencies.

For models with complex coefficients, if you specify a frequency range of `[wmin,wmax]` for your plot, then in:

- Log frequency scale, the plot frequency limits are set to `[wmin,wmax]` and the plot shows two branches, one for positive frequencies `[wmin,wmax]` and one for negative frequencies `[-wmax,-wmin]`.
- Linear frequency scale, the plot frequency limits are set to `[-wmax,wmax]` and the plot shows a single branch with a symmetric frequency range centered at a frequency value of zero.

Specify frequencies in units of `rad/TimeUnit`, where `TimeUnit` is the `TimeUnit` property of the model.

type — Option to plot modified singular values

1 | 2 | 3

Option to plot modified singular values, specified as one of the following options:

- 1 to plot the singular values of the frequency response H^{-1} , where H is the frequency response of `sys`.
- 2 to plot the singular values of the frequency response $I+H$.
- 3 to plot the singular values of the frequency response $I+H^{-1}$.

You can only use the `type` argument for *square systems*, that is, systems that have the same number of inputs and outputs.

Output Arguments

sv — Singular values of frequency response

matrix

Singular values of the frequency response in absolute units, returned as a matrix. `sv` contains the singular values computed at the frequencies `w` if you supplied them, or `wout` if you did not. For a system `sys` with `Nu` inputs and `Ny` outputs, `sv` has $\min(Nu, Ny)$ rows, and as many columns as there are values in `w` or `wout`.

wout — Frequencies

vector

Frequencies at which the function returns the system response, returned as a column vector. The function chooses the frequency values based on the model dynamics, unless you specify frequencies using the input argument `w`.

`wout` also contains negative frequency values for models with complex coefficients.

Frequency values are in radians per `TimeUnit`, where `TimeUnit` is the value of the `TimeUnit` property of `sys`.

Tips

- When you need additional plot customization options, use `sigmaplot` instead.

Algorithms

`sigma` uses the MATLAB function `svd` to compute the singular values of the complex frequency response.

- For an `frd` model, `sigma` computes the singular values of `sys.ResponseData` at the frequencies, `sys.Frequency`.
- For continuous-time `tf`, `ss`, or `zpk` models with transfer function $H(s)$, `sigma` computes the singular values of $H(j\omega)$ as a function of the frequency ω .
- For discrete-time `tf`, `ss`, or `zpk` models with transfer function $H(z)$ and sample time T_s , `sigma` computes the singular values of

$$H(e^{j\omega T_s})$$

for frequencies ω between 0 and the Nyquist frequency $\omega_N = \pi/T_s$.

Version History

Introduced before R2006a

See Also

`sigmaplot` | `freqresp` | `nyquist` | `bode`

Topics

“Frequency-Domain Responses”
“Dynamic System Models”

sigmaoptions

Sigma plot options

Description

Use the `sigmaoptions` command to create a `SigmaOptions` object to customize your sigma plot appearance. You can also use the command to override the plot preference settings in the MATLAB session in which you create the sigma plots.

Creation

Syntax

```
plotoptions = sigmaoptions  
plotoptions = sigmaoptions('cstprefs')
```

Description

`plotoptions = sigmaoptions` returns a default set of plot options for use with the `sigmaplot` command. You can use these options to customize sigma plot appearance using the command line. This syntax is useful when you want to write a script to generate plots that look the same regardless of the preference settings of the MATLAB session in which you run the script.

`plotoptions = sigmaoptions('cstprefs')` initializes the plot options with the options you selected in the Control System Toolbox Preferences Editor. For more information about the editor, see “Toolbox Preferences Editor”. This syntax is useful when you want to change a few plot options but otherwise use your default preferences. A script that uses this syntax might generate results that look different when run in a session with different preferences.

Properties

FreqUnits — Frequency units

'rad/s' (default)

Frequency units, specified as one of the following values:

- 'Hz'
- 'rad/s'
- 'rpm'
- 'kHz'
- 'MHz'
- 'GHz'
- 'rad/nanosecond'
- 'rad/microsecond'

- 'rad/millisecond'
- 'rad/minute'
- 'rad/hour'
- 'rad/day'
- 'rad/week'
- 'rad/month'
- 'rad/year'
- 'cycles/nanosecond'
- 'cycles/microsecond'
- 'cycles/millisecond'
- 'cycles/hour'
- 'cycles/day'
- 'cycles/week'
- 'cycles/month'
- 'cycles/year'

FreqScale — Frequency scale

'log' (default) | 'linear'

Frequency scale, specified as either 'log' or 'linear'.

MagUnits — Magnitude units

'dB' (default) | 'abs'

Magnitude units, specified as either 'dB' or absolute value 'abs'.

MagScale — Magnitude scale

'linear' (default) | 'log'

Magnitude scale, specified as either 'log' or 'linear'.

IOWGrouping — Grouping of input-output pairs

'none' (default) | 'inputs' | 'outputs' | 'all'

Grouping of input-output (I/O) pairs, specified as one of the following:

- 'none' — No input-output grouping.
- 'inputs' — Group only the inputs.
- 'outputs' — Group only the outputs.
- 'all' — Group all the I/O pairs.

InputLabelStyle — Input label style

structure (default)

Input label style, specified as a structure with the following fields:

- **FontSize** — Font size, specified as a scalar value greater than zero in point units. The default font size depends on the specific operating system and locale. One point equals 1/72 inch.

- **FontWeight** — Character thickness, specified as 'Normal' or 'bold'. MATLAB uses the **FontWeight** property to select a font from those available on your system. Not all fonts have a bold weight. Therefore, specifying a bold font weight can still result in the normal font weight.
- **FontAngle** — Character slant, specified as 'Normal' or 'italic'. Not all fonts have both font styles. Therefore, the italic font might look the same as the normal font.
- **Color** — Text color, specified as an RGB triplet. The default color is dark grey with the RGB triplet `[0.4,0.4,0.4]`.
- **Interpreter** — Text interpreter, specified as one of these values:
 - 'tex' — Interpret characters using a subset of TeX markup. This is the default value of **Interpreter**.
 - 'latex' — Interpret characters using LaTeX markup.
 - 'none' — Display literal characters.

OutputLabels — Output label style

structure (default)

Output label style, specified as a structure with the following fields:

- **FontSize** — Font size, specified as a scalar value greater than zero in point units. The default font size depends on the specific operating system and locale. One point equals 1/72 inch.
- **FontWeight** — Character thickness, specified as 'Normal' or 'bold'. MATLAB uses the **FontWeight** property to select a font from those available on your system. Not all fonts have a bold weight. Therefore, specifying a bold font weight can still result in the normal font weight.
- **FontAngle** — Character slant, specified as 'Normal' or 'italic'. Not all fonts have both font styles. Therefore, the italic font might look the same as the normal font.
- **Color** — Text color, specified as an RGB triplet. The default color is dark grey with the RGB triplet `[0.4,0.4,0.4]`.
- **Interpreter** — Text interpreter, specified as one of these values:
 - 'tex' — Interpret characters using a subset of TeX markup. This is the default value of **Interpreter**.
 - 'latex' — Interpret characters using LaTeX markup.
 - 'none' — Display literal characters.

InputVisible — Input visibility toggle

{'on'} (default) | {'off'} | cell array

Input visibility toggle, specified as either {'on'}, {'off'} or a cell array with multiple elements.

OutputVisible — Output visibility toggle

{'on'} (default) | {'off'} | cell array

Output visibility toggle, specified as either {'on'}, {'off'} or a cell array with multiple elements.

Title — Title text and style

structure (default)

Title text and style, specified as a structure with the following fields:

- **String** — Label text, specified as a character vector. By default, the plot is titled 'Singular Values'.
- **FontSize** — Font size, specified as a scalar value greater than zero in point units. The default font size depends on the specific operating system and locale. One point equals 1/72 inch.
- **FontWeight** — Character thickness, specified as 'Normal' or 'bold'. MATLAB uses the **FontWeight** property to select a font from those available on your system. Not all fonts have a bold weight. Therefore, specifying a bold font weight can still result in the normal font weight.
- **FontAngle** — Character slant, specified as 'Normal' or 'italic'. Not all fonts have both font styles. Therefore, the italic font might look the same as the normal font.
- **Color** — Text color, specified as an RGB triplet. The default color is black specified by the RGB triplet [0,0,0].
- **Interpreter** — Text interpreter, specified as one of these values:
 - 'tex' — Interpret characters using a subset of TeX markup. This is the default value of **Interpreter**.
 - 'latex' — Interpret characters using LaTeX markup.
 - 'none' — Display literal characters.

XLabel — X-axis label text and style

structure (default)

X-axis label text and style, specified as a structure with the following fields:

- **String** — Label text, specified as a character vector. By default, the axis is titled based on the frequency units **FreqUnits**.
- **FontSize** — Font size, specified as a scalar value greater than zero in point units. The default font size depends on the specific operating system and locale. One point equals 1/72 inch.
- **FontWeight** — Character thickness, specified as 'Normal' or 'bold'. MATLAB uses the **FontWeight** property to select a font from those available on your system. Not all fonts have a bold weight. Therefore, specifying a bold font weight can still result in the normal font weight.
- **FontAngle** — Character slant, specified as 'Normal' or 'italic'. Not all fonts have both font styles. Therefore, the italic font might look the same as the normal font.
- **Color** — Text color, specified as an RGB triplet. The default color is black specified by the RGB triplet [0,0,0].
- **Interpreter** — Text interpreter, specified as one of these values:
 - 'tex' — Interpret characters using a subset of TeX markup. This is the default value of **Interpreter**.
 - 'latex' — Interpret characters using LaTeX markup.
 - 'none' — Display literal characters.

YLabel — Y-axis label text and style

structure (default)

Y-axis label text and style, specified as a structure with the following fields:

- **String** — Label text, specified as a cell array of character vectors. By default, the axis is titled based on the magnitude units **MagUnits**.

- **FontSize** — Font size, specified as a scalar value greater than zero in point units. The default font size depends on the specific operating system and locale. One point equals 1/72 inch.
- **FontWeight** — Character thickness, specified as 'Normal' or 'bold'. MATLAB uses the **FontWeight** property to select a font from those available on your system. Not all fonts have a bold weight. Therefore, specifying a bold font weight can still result in the normal font weight.
- **FontAngle** — Character slant, specified as 'Normal' or 'italic'. Not all fonts have both font styles. Therefore, the italic font might look the same as the normal font.
- **Color** — Text color, specified as an RGB triplet. The default color is black specified by the RGB triplet [0,0,0].
- **Interpreter** — Text interpreter, specified as one of these values:
 - 'tex' — Interpret characters using a subset of TeX markup. This is the default value of **Interpreter**.
 - 'latex' — Interpret characters using LaTeX markup.
 - 'none' — Display literal characters.

TickLabel — Tick label style

structure (default)

Tick label style, specified as a structure with the following fields:

- **FontSize** — Font size, specified as a scalar value greater than zero in point units. The default font size depends on the specific operating system and locale. One point equals 1/72 inch.
- **FontWeight** — Character thickness, specified as 'Normal' or 'bold'. MATLAB uses the **FontWeight** property to select a font from those available on your system. Not all fonts have a bold weight. Therefore, specifying a bold font weight can still result in the normal font weight.
- **FontAngle** — Character slant, specified as 'Normal' or 'italic'. Not all fonts have both font styles. Therefore, the italic font might look the same as the normal font.
- **Color** — Text color, specified as an RGB triplet. The default color is black specified by the RGB triplet [0,0,0].

Grid — Toggle grid display

'off' (default) | 'on'

Toggle grid display on the plot, specified as either 'off' or 'on'.

GridColor — Color of the grid lines

[0.15,0.15,0.15] (default) | RGB triplet

Color of the grid lines, specified as an RGB triplet. The default color is light grey specified by the RGB triplet [0.15,0.15,0.15].

XLimMode — X-axis limit selection mode

'auto' (default) | 'manual' | cell array

Selection mode for the x-axis limits, specified as one of these values:

- 'auto' — Enable automatic limit selection, which is based on the total span of the plotted data.
- 'manual' — Manually specify the axis limits. To specify the axis limits, set the **XLim** property.

YLimMode — Y-axis limit selection mode

'auto' (default) | 'manual' | cell array

Selection mode for the y-axis limits, specified as one of these values:

- 'auto' — Enable automatic limit selection, which is based on the total span of the plotted data.
- 'manual' — Manually specify the axis limits. To specify the axis limits, set the YLim property.

XLim — X-axis limits

'{[1,10]}' (default) | cell array of two-element vector of the form [min,max] | cell array

X-axis limits, specified as a cell array of two-element vector of the form [min,max].

YLim — Y-axis limits

'{[1,10]}' (default) | cell array of two-element vector of the form [min,max] | cell array

Y-axis limits, specified as a cell array of two-element vector of the form [min,max].

Object Functions

`sigmaplot` Plot singular values of frequency response with additional plot customization options

Examples

Customize Sigma Plot using Plot Handle

For this example, use the plot handle to change the frequency units to Hz and turn on the grid.

Generate a random state-space model with 5 states and create the sigma plot with plot handle h.

```
rng("default")
sys = rss(5);
h = sigmaplot(sys);
```

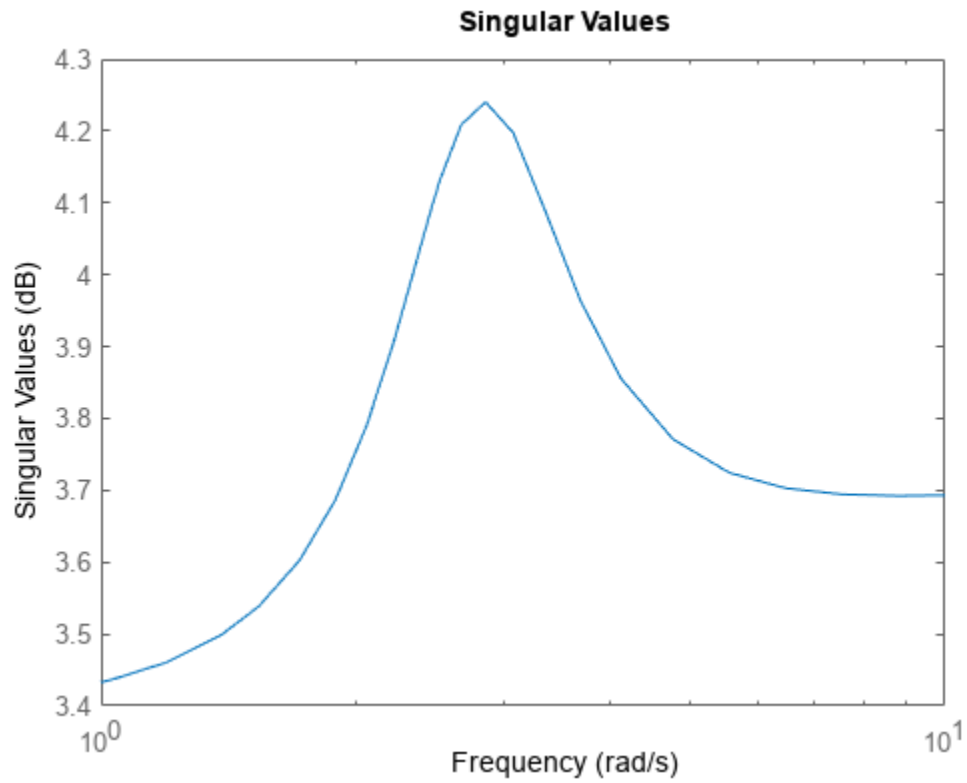

Change the units to Hz and turn on the grid. To do so, edit properties of the plot handle, h using `setoptions`.

```
setoptions(h, 'FreqUnits', 'Hz', 'Grid', 'on');
```

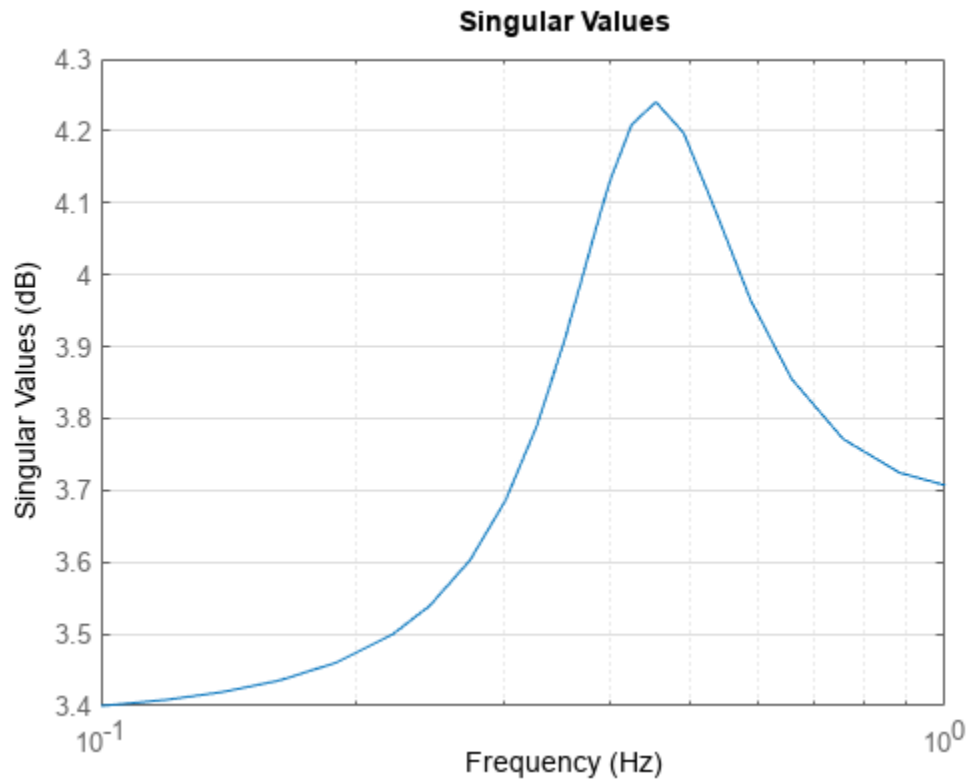

The sigma plot automatically updates when you call `setoptions`.

Alternatively, you can also use the `sigmaoptions` command to specify the required plot options. First, create an options set based on the toolbox preferences.

```
p = sigmaoptions('cstprefs');
```

Change properties of the options set by setting the frequency units to Hz and enable the grid.

```
p.FreqUnits = 'Hz';  
p.Grid = 'on';  
sigmaplot(sys,p);
```

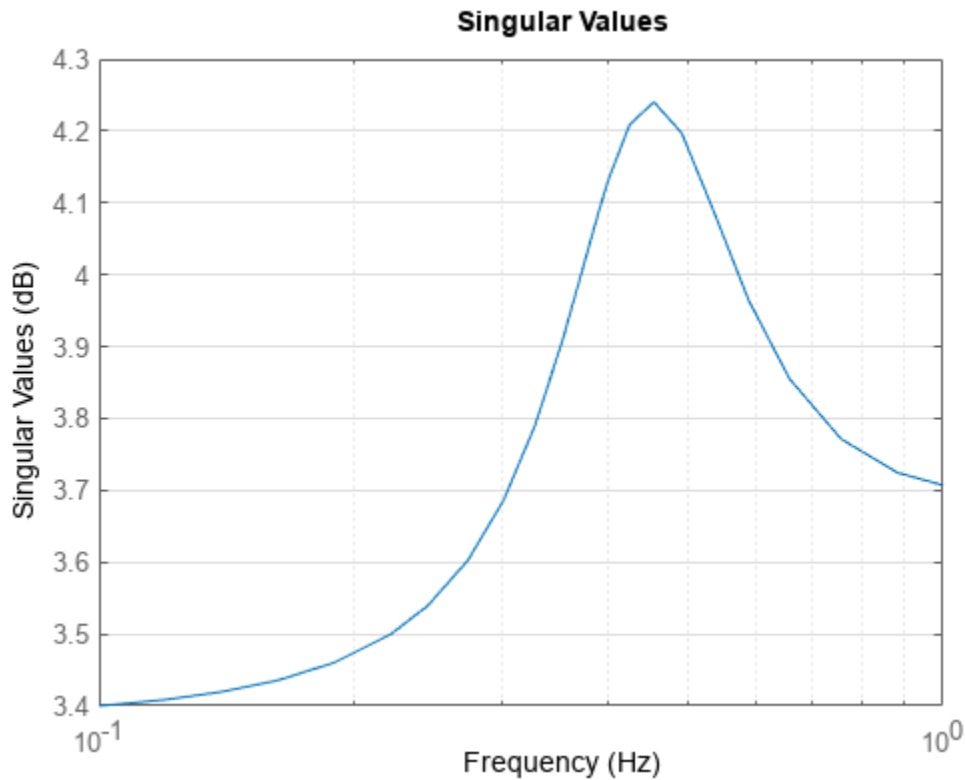

You can use the same option set to create multiple sigma plots with the same customization. Depending on your own toolbox preferences, the plot you obtain might look different from this plot. Only the properties that you set explicitly, in this example `Grid` and `FreqUnits`, override the toolbox preferences.

Custom Sigma Plot Settings Independent of Preferences

For this example, create a sigma plot that uses 15-point red text for the title. This plot should look the same, regardless of the preferences of the MATLAB session in which it is generated.

First, create a default options set using `sigmaoptions`.

```
plotoptions = sigmaoptions;
```

Next, change the required properties of the options set `plotoptions`.

```
plotoptions.Title.FontSize = 15;
plotoptions.Title.Color = [1 0 0];
plotoptions.FreqUnits = 'Hz';
plotoptions.Grid = 'on';
```

Now, create a sigma plot using the options set `plotoptions`.

```
h = sigmaplot(tf(1,[1,1]),plotoptions);
```

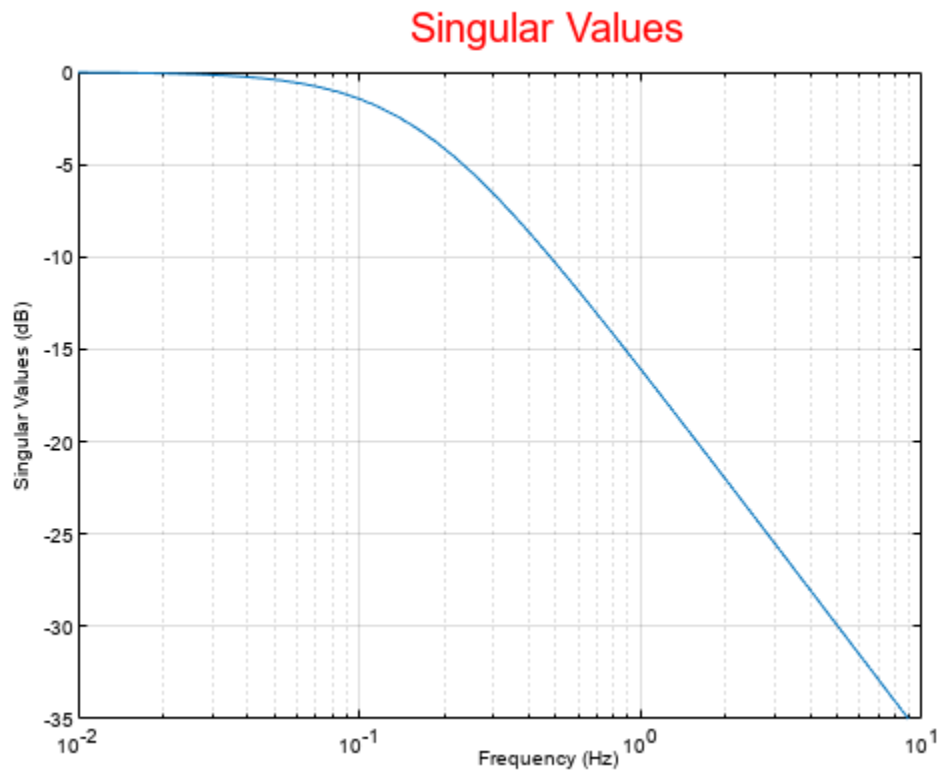

Because `plotoptions` begins with a fixed set of options, the plot result is independent of the toolbox preferences of the MATLAB session.

Customized Sigma Plot of Transfer Function

For this example, create a sigma plot of the following continuous-time SISO dynamic system. Then, turn the grid on, rename the plot and change the frequency scale.

$$\text{sys}(s) = \frac{s^2 + 0.1s + 7.5}{s^4 + 0.12s^3 + 9s^2}$$

Create the transfer function `sys`.

```
sys = tf([1 0.1 7.5],[1 0.12 9 0 0]);
```

Next, create the options set using `sigmaoptions` and change the required plot properties.

```
plotoptions = sigmaoptions;
plotoptions.Grid = 'on';
plotoptions.FreqScale = 'linear';
plotoptions.Title.String = 'Singular Value Plot of Transfer Function';
```

Now, create the sigma plot with the custom option set `plotoptions`.

```
h = sigmaplot(sys,plotoptions);
```

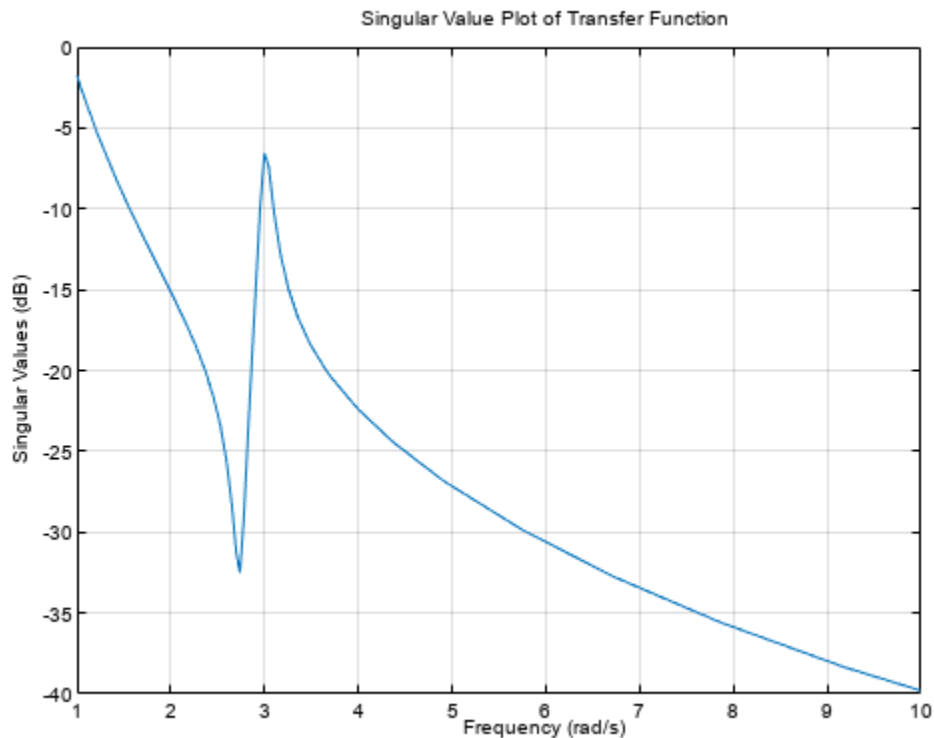

`sigmaplot` automatically selects the plot range based on the system dynamics.

Singular Value Plot of Identified Parametric and Nonparametric Models

For this example, compare the SV for the frequencies of a parametric model, identified from input/output data, to a non-parametric model identified using the same data. Identify parametric and non-parametric models based on the data.

Load the data and create the parametric and non-parametric models using `tfest` and `spa`, respectively.

```
load iddata2 z2;
w = linspace(0,10*pi,128);
sys_np = spa(z2,[],w);
sys_p = tfest(z2,2);
```

`spa` and `tfest` require System Identification Toolbox™ software. The model `sys_np` is a non-parametric identified model while, `sys_p` is a parametric identified model.

Create an options set to turn the grid on. Then, create a sigma plot that includes both systems using this options set.

```
plotoptions = sigmaoptions;
plotoptions.Grid = 'on';
```



```
h = sigmaplot(sys_p,'b--',sys_np,'r--',w,plotoptions);
legend('Parametric Model','Non-Parametric model');
```

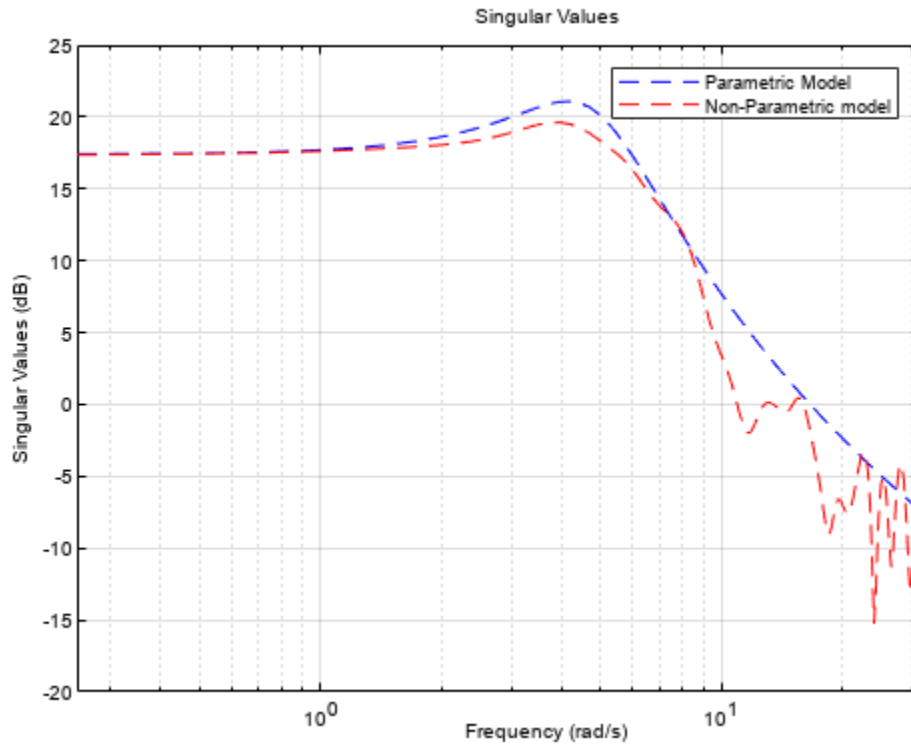

Modified Singular Value Plot of MIMO System

Consider the following two-input, two-output dynamic system.

$$H(s) = \begin{bmatrix} 0 & \frac{3s}{s^2 + s + 10} \\ \frac{s+1}{s+5} & \frac{2}{s+6} \end{bmatrix}.$$

Plot the singular value responses of $H(s)$ and $I + H(s)$. Set appropriate titles using the plot option set.

```
H = [0, tf([3 0],[1 1 10]) ; tf([1 1],[1 5]), tf(2,[1 6])];
opts1 = sigmaoptions;
opts1.Grid = 'on';
opts1.Title.String = 'Singular Value Plot of H(s)';
h1 = sigmaplot(H,opts1);
```

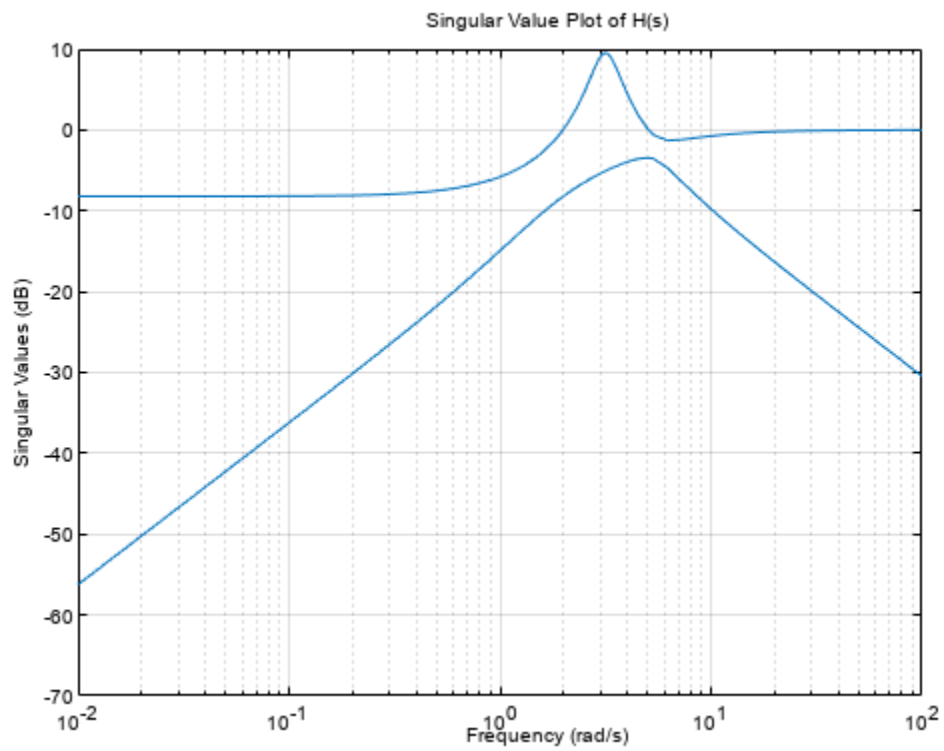

Use input 2 to plot the modified SV of type, $I + H(s)$.

```
opts2 = sigmaoptions;  
opts2.Grid = 'on';  
opts2.Title.String = 'Singular Value Plot of I+H(s)';  
h2 = sigmaplot(H,[],2,opts2);
```

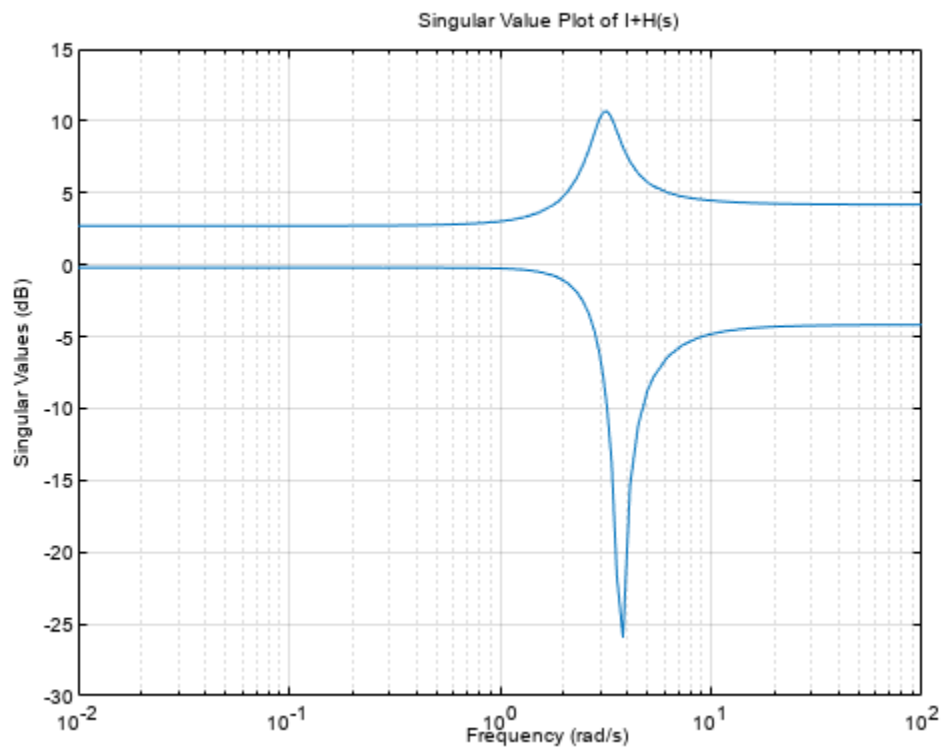

Version History

Introduced in R2008a

See Also

[getoptions](#) | [setoptions](#) | [sigmaplot](#)

Topics

“Toolbox Preferences Editor”

sigmaplot

Plot singular values of frequency response with additional plot customization options

Syntax

```
h = sigmaplot(sys)
h = sigmaplot(sys1,sys2,...,sysN)
h = sigmaplot(sys1,LineStyle1,...,sysN,LineStyleN)
h = sigmaplot( ____,w)
h = sigmaplot( ____,type)
h = sigmaplot(AX, ____)
h = sigmaplot( ____,plotoptions)
```

Description

`sigmaplot` lets you plot the singular values (SV) of frequency response of a dynamic system model with a broader range of plot customization options than `sigma`. You can use `sigmaplot` to obtain the plot handle and use it to customize the plot, such as modify the axes labels, limits and units. You can also use `sigmaplot` to draw an SV plot on an existing set of axes represented by an axes handle. To customize an existing SV plot using the plot handle:

- 1 Obtain the plot handle
- 2 Use `getoptions` to obtain the option set
- 3 Update the plot using `setoptions` to modify the required options

For more information, see “Customizing Response Plots from the Command Line”. To create SV plots with default options or to extract the frequency response data, use `sigma`.

`h = sigmaplot(sys)` plots the singular values (SV) of the frequency response of the dynamic system model `sys` and returns the plot handle `h` to the plot. You can use this handle `h` to customize the plot with the `getoptions` and `setoptions` commands.

`h = sigmaplot(sys1,sys2,...,sysN)` plots the SV of multiple dynamic systems `sys1,sys2,...,sysN` on the same plot. All systems must have the same number of inputs and outputs to use this syntax.

`h = sigmaplot(sys1,LineStyle1,...,sysN,LineStyleN)` sets the line style, marker type, and color for the SV plot of each system. All systems must have the same number of inputs and outputs to use this syntax.

`h = sigmaplot(____,w)` plots singular values for frequencies specified by the frequencies in `w`.

- If `w` is a cell array of the form `{wmin,wmax}`, then `sigmaplot` plots the singular values at frequencies ranging between `wmin` and `wmax`.
- If `w` is a vector of frequencies, then `sigmaplot` plots the singular values at each specified frequency.

You can use `w` with any of the input-argument combinations in previous syntaxes.

See `logspace` to generate logarithmically spaced frequency vectors.

`h = sigmaplot(___, type)` plots the modified singular value responses based on the `type` argument. Specify `type` as:

- 1 to plot the SV of the frequency response H^{-1} , where H is the frequency response of `sys`.
- 2 to plot the SV of the frequency response $I+H$.
- 3 to plot the SV of the frequency response $I+H^{-1}$.

You can only use the `type` argument for *square systems*, that is, systems that have the same number of inputs and outputs.

`h = sigmaplot(AX, ___)` plots the singular values on the `Axes` object in the current figure with the handle `AX`.

`h = sigmaplot(___, plotoptions)` plots the singular values with the options set specified in `plotoptions`. You can use these options to customize the SV plot appearance using the command line. Settings you specify in `plotoptions` overrides the preference settings in the MATLAB session in which you run `sigmaplot`. Therefore, this syntax is useful when you want to write a script to generate multiple plots that look the same regardless of the local preferences.

Examples

Customize Sigma Plot using Plot Handle

For this example, use the plot handle to change the frequency units to Hz and turn on the grid.

Generate a random state-space model with 5 states and create the sigma plot with plot handle `h`.

```
rng("default")
sys = rss(5);
h = sigmaplot(sys);
```

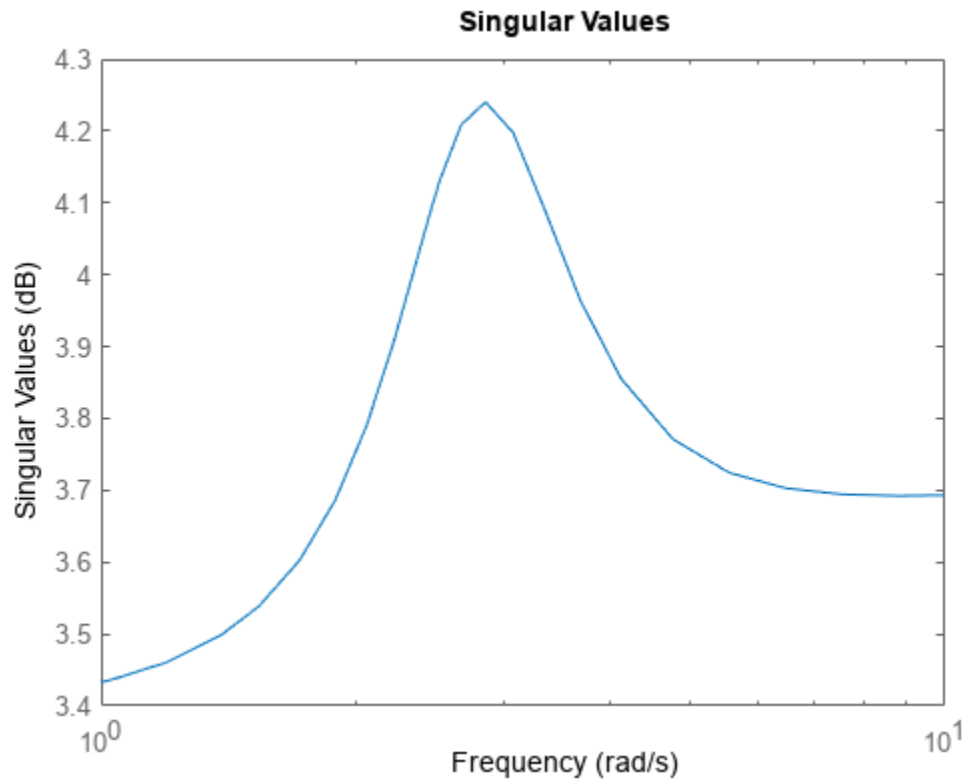

Change the units to Hz and turn on the grid. To do so, edit properties of the plot handle, h using `setoptions`.

```
setoptions(h, 'FreqUnits', 'Hz', 'Grid', 'on');
```

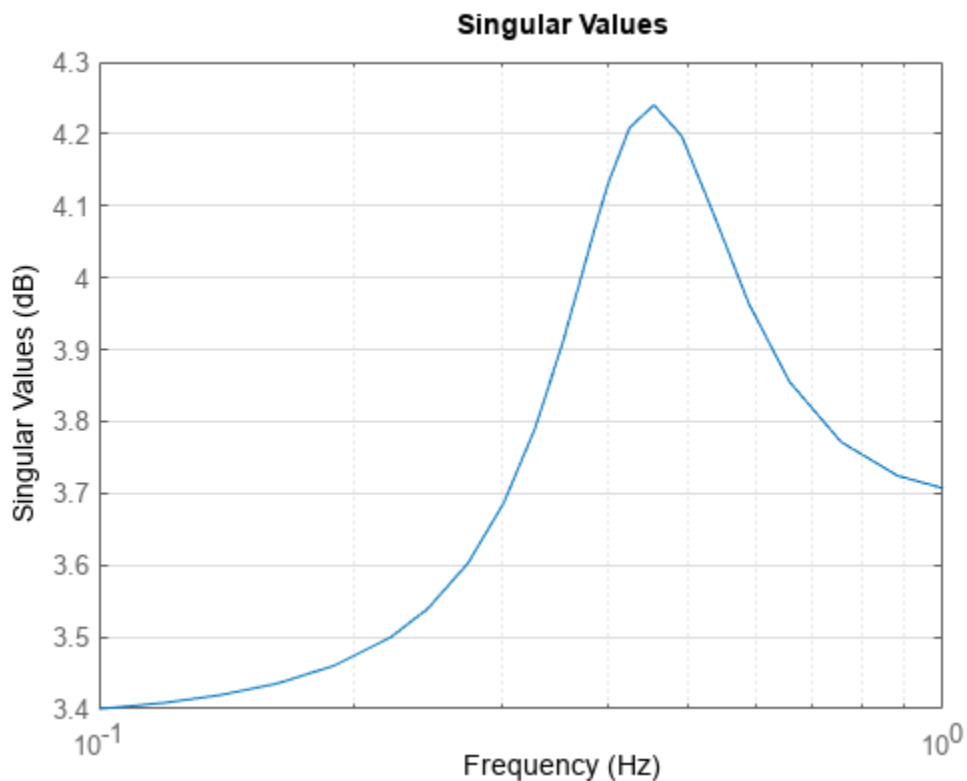

The sigma plot automatically updates when you call `setoptions`.

Alternatively, you can also use the `sigmaoptions` command to specify the required plot options. First, create an options set based on the toolbox preferences.

```
p = sigmaoptions('cstprefs');
```

Change properties of the options set by setting the frequency units to Hz and enable the grid.

```
p.FreqUnits = 'Hz';  
p.Grid = 'on';  
sigmaplot(sys,p);
```

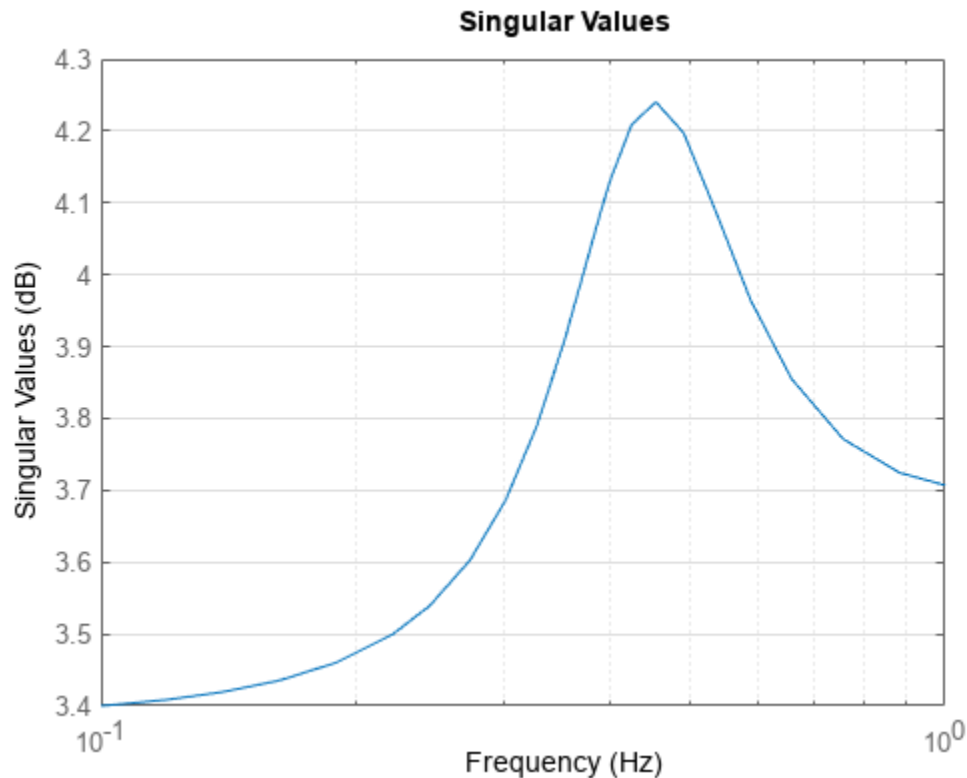

You can use the same option set to create multiple sigma plots with the same customization. Depending on your own toolbox preferences, the plot you obtain might look different from this plot. Only the properties that you set explicitly, in this example `Grid` and `FreqUnits`, override the toolbox preferences.

Custom Sigma Plot Settings Independent of Preferences

For this example, create a sigma plot that uses 15-point red text for the title. This plot should look the same, regardless of the preferences of the MATLAB session in which it is generated.

First, create a default options set using `sigmaoptions`.

```
plotoptions = sigmaoptions;
```

Next, change the required properties of the options set `plotoptions`.

```
plotoptions.Title.FontSize = 15;
plotoptions.Title.Color = [1 0 0];
plotoptions.FreqUnits = 'Hz';
plotoptions.Grid = 'on';
```

Now, create a sigma plot using the options set `plotoptions`.

```
h = sigmaplot(tf(1,[1,1]),plotoptions);
```

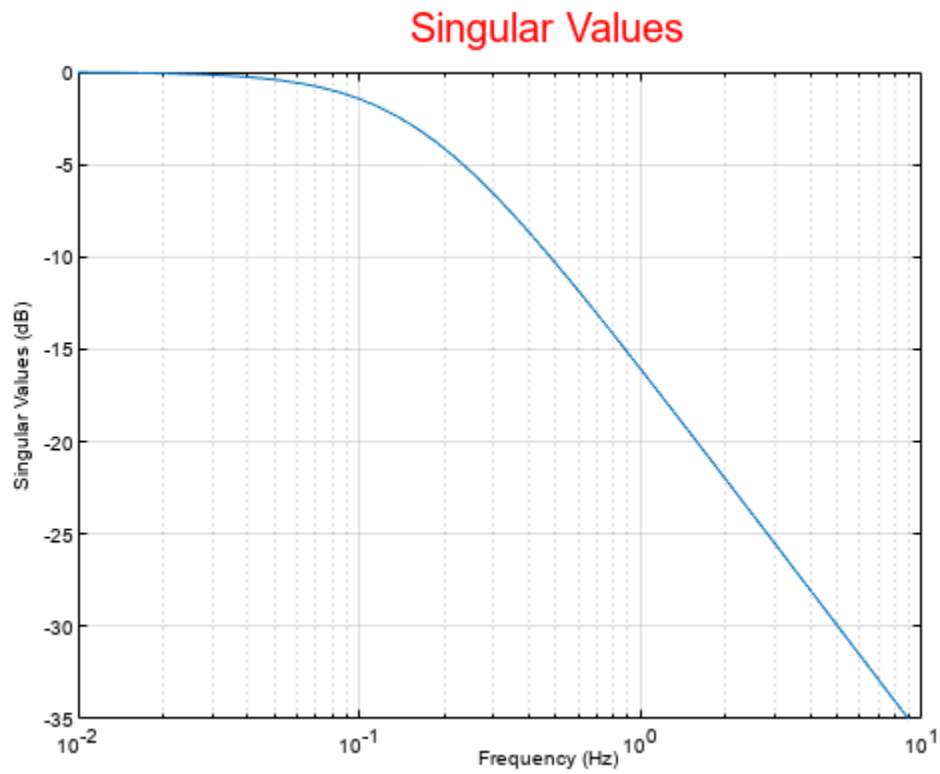
Because `plotoptions` begins with a fixed set of options, the plot result is independent of the toolbox preferences of the MATLAB session.

Customized Sigma Plot of Transfer Function

For this example, create a sigma plot of the following continuous-time SISO dynamic system. Then, turn the grid on, rename the plot and change the frequency scale.

$$\text{sys}(s) = \frac{s^2 + 0.1s + 7.5}{s^4 + 0.12s^3 + 9s^2}$$

Create the transfer function `sys`.

```
sys = tf([1 0.1 7.5],[1 0.12 9 0 0]);
```

Next, create the options set using `sigmaoptions` and change the required plot properties.

```
plotoptions = sigmaoptions;
plotoptions.Grid = 'on';
plotoptions.FreqScale = 'linear';
plotoptions.Title.String = 'Singular Value Plot of Transfer Function';
```

Now, create the sigma plot with the custom option set `plotoptions`.

```
h = sigmaplot(sys,plotoptions);
```

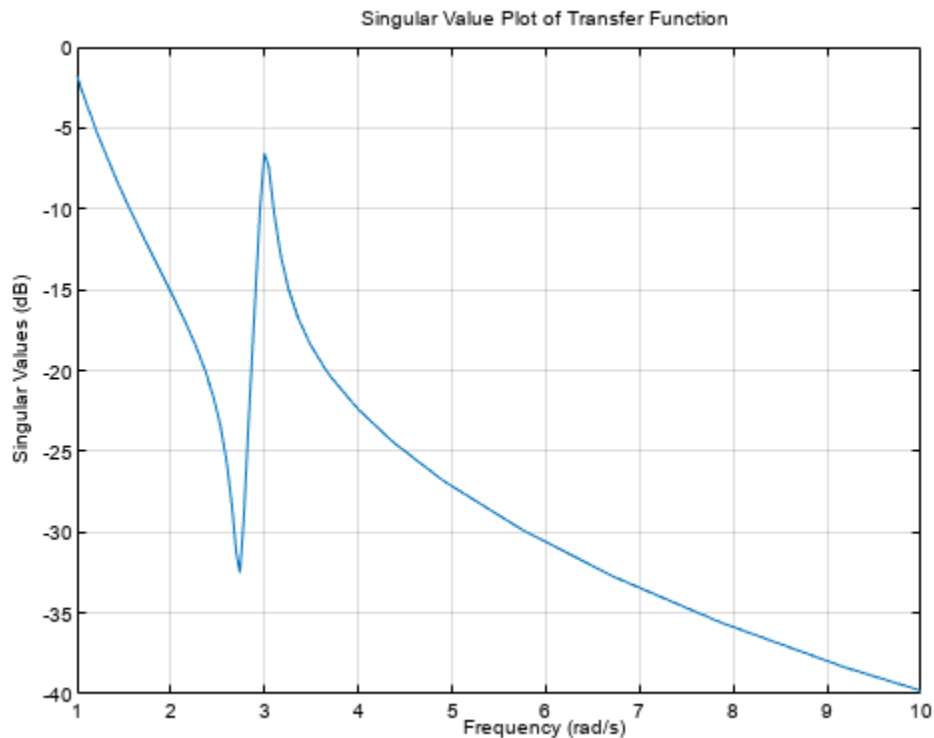

`sigmaplot` automatically selects the plot range based on the system dynamics.

Sigma Plot with Specified Frequency Scale and Units

For this example, consider a MIMO state-space model with 3 inputs, 3 outputs and 3 states. Create a sigma plot with linear frequency scale, frequency units in Hz and turn the grid on.

Create the MIMO state-space model `sys_mimo`.

```
J = [8 -3 -3; -3 8 -3; -3 -3 8];
F = 0.2*eye(3);
A = -J\F;
B = inv(J);
C = eye(3);
D = 0;
sys_mimo = ss(A,B,C,D);
size(sys_mimo)
```

State-space model with 3 outputs, 3 inputs, and 3 states.

Create a sigma plot with plot handle `h` and use `getoptions` for a list of the options available.

```
h = sigmaplot(sys_mimo);
```

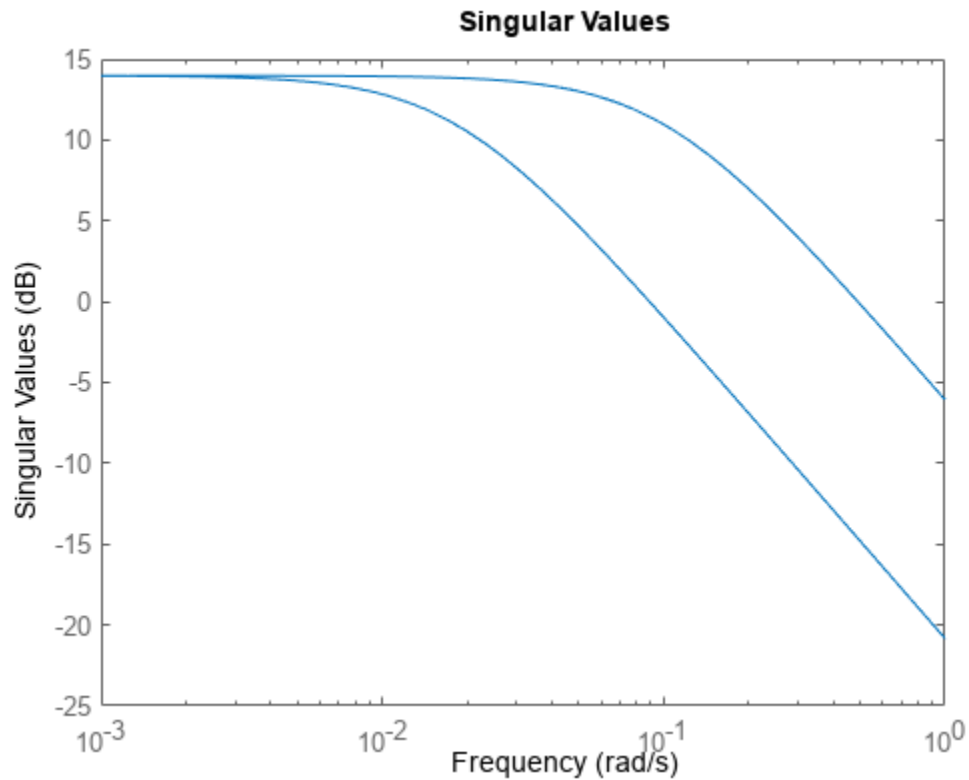

```
p = getoptions(h)
```

```
p =
```

```

    FreqUnits: 'rad/s'
    FreqScale: 'log'
    MagUnits: 'dB'
    MagScale: 'linear'
    IOGrouping: 'none'
    InputLabels: [1x1 struct]
    OutputLabels: [1x1 struct]
    InputVisible: {0x1 cell}
    OutputVisible: {0x1 cell}
    Title: [1x1 struct]
    XLabel: [1x1 struct]
    YLabel: [1x1 struct]
    TickLabel: [1x1 struct]
    Grid: 'off'
    GridColor: [0.1500 0.1500 0.1500]
    XLim: {[1.0000e-03 1]}
    YLim: {[ -25 15]}
    XLimMode: {'auto'}
    YLimMode: {'auto'}

```

Use `setoptions` to update the plot with the requires customization.

```
setoptions(h, 'FreqScale', 'linear', 'FreqUnits', 'Hz', 'Grid', 'on');
```

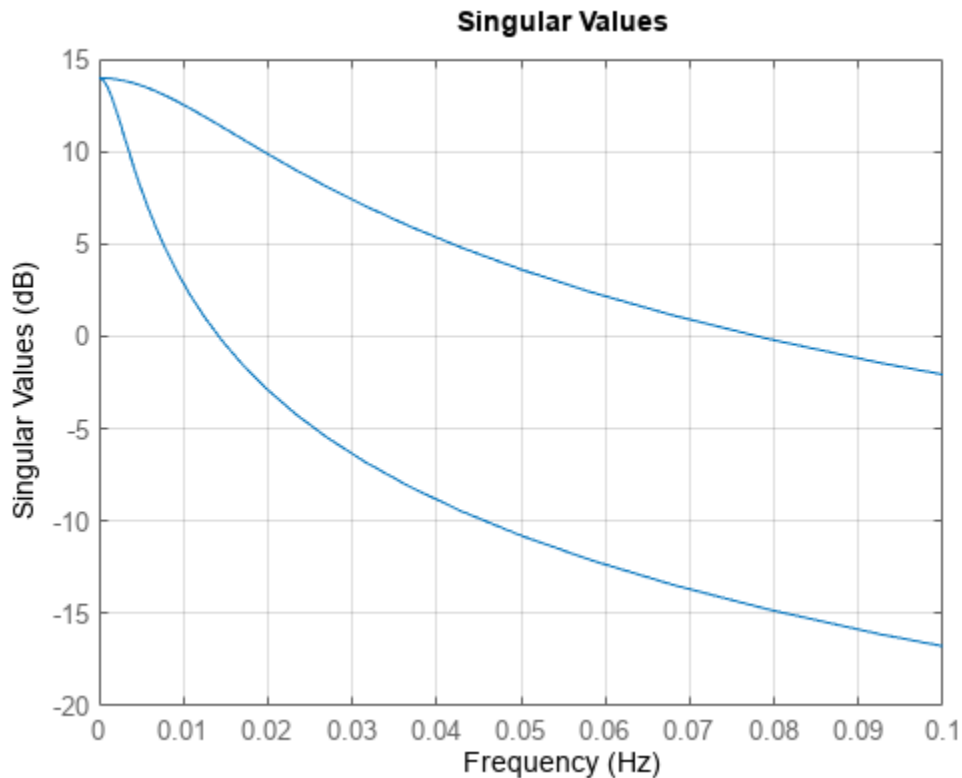

The sigma plot automatically updates when you call `setoptions`.

Singular Value Plot of Identified Parametric and Nonparametric Models

For this example, compare the SV for the frequencies of a parametric model, identified from input/output data, to a non-parametric model identified using the same data. Identify parametric and non-parametric models based on the data.

Load the data and create the parametric and non-parametric models using `tfest` and `spa`, respectively.

```
load iddata2 z2;
w = linspace(0,10*pi,128);
sys_np = spa(z2,[],w);
sys_p = tfest(z2,2);
```

`spa` and `tfest` require System Identification Toolbox™ software. The model `sys_np` is a non-parametric identified model while, `sys_p` is a parametric identified model.

Create an options set to turn the grid on. Then, create a sigma plot that includes both systems using this options set.

```
plotoptions = sigmaoptions;
plotoptions.Grid = 'on';
```

```
h = sigmaplot(sys_p,'b--',sys_np,'r--',w,plotoptions);
legend('Parametric Model','Non-Parametric model');
```

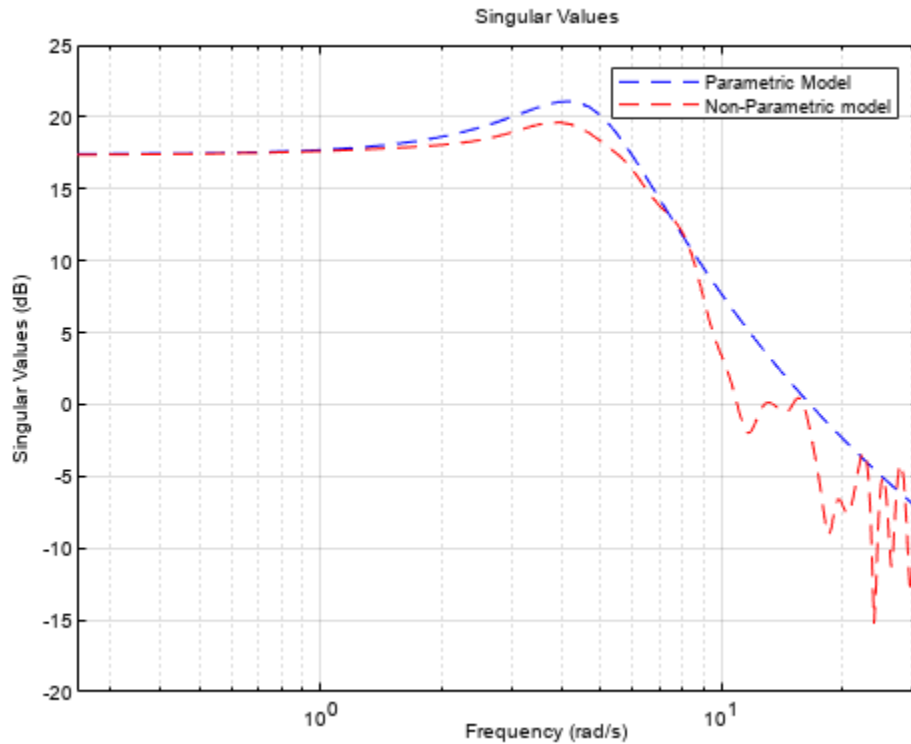

Modified Singular Value Plot of MIMO System

Consider the following two-input, two-output dynamic system.

$$H(s) = \begin{bmatrix} 0 & \frac{3s}{s^2 + s + 10} \\ \frac{s+1}{s+5} & \frac{2}{s+6} \end{bmatrix}.$$

Plot the singular value responses of $H(s)$ and $I + H(s)$. Set appropriate titles using the plot option set.

```
H = [0, tf([3 0],[1 1 10]) ; tf([1 1],[1 5]), tf(2,[1 6])];
opts1 = sigmaoptions;
opts1.Grid = 'on';
opts1.Title.String = 'Singular Value Plot of H(s)';
h1 = sigmaplot(H,opts1);
```

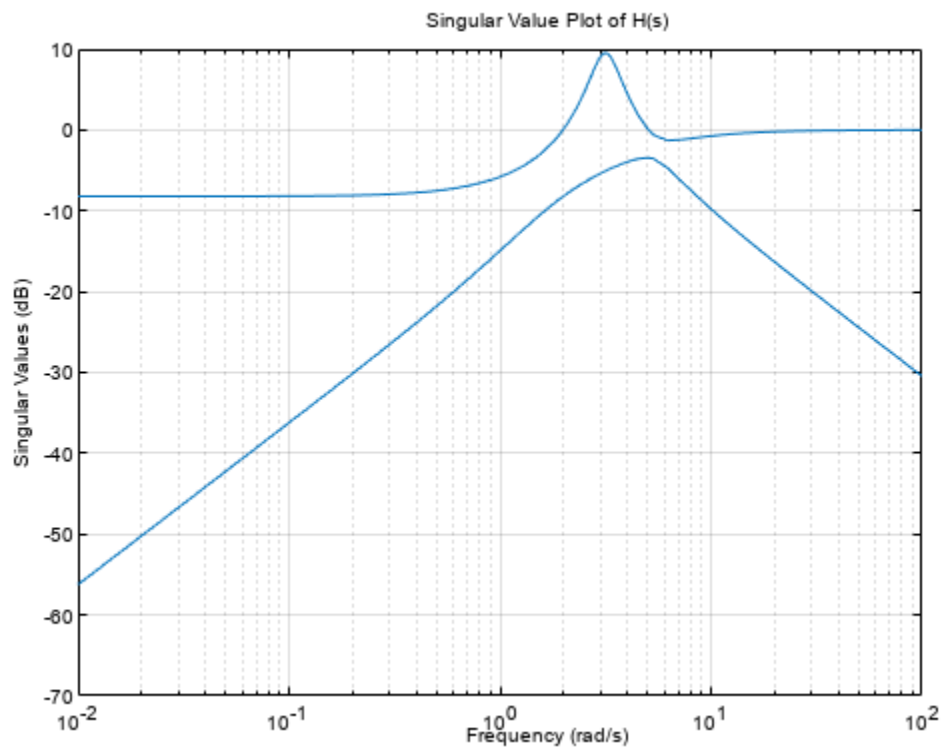

Use input 2 to plot the modified SV of type, $I + H(s)$.

```
opts2 = sigmaoptions;  
opts2.Grid = 'on';  
opts2.Title.String = 'Singular Value Plot of I+H(s)';  
h2 = sigmaplot(H,[],2,opts2);
```

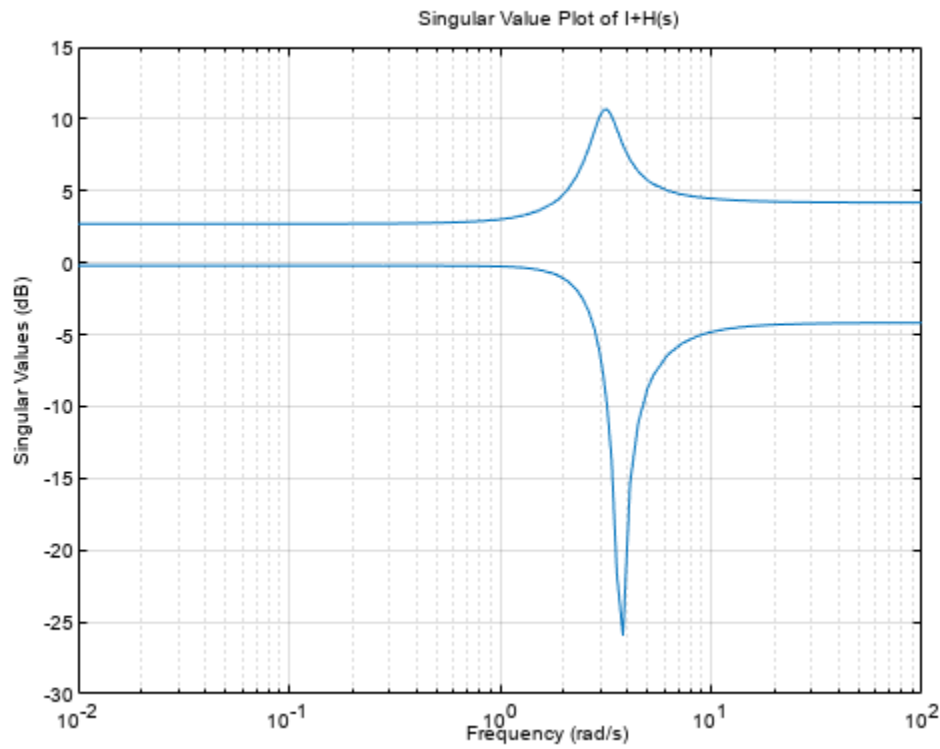

Input Arguments

sys — Dynamic system

dynamic system model | model array

Dynamic system, specified as a SISO or MIMO dynamic system model or array of dynamic system models. Dynamic systems that you can use include:

- Continuous-time or discrete-time numeric LTI models, such as `tf`, `zpk`, or `ss` models.
- Sparse state-space models, such as `sparss` or `mechss` models. Frequency grid `w` must be specified for sparse models.
- Generalized or uncertain LTI models such as `genss` or `uss` models. (Using uncertain models requires Robust Control Toolbox software.)
 - For tunable control design blocks, the function evaluates the model at its current value to plot the SV.
 - For uncertain control design blocks, the function plots the SV at the nominal value and random samples of the model.
- Frequency-response data models such as `frd` models. For such models, the function plots the SV at frequencies defined in the model.
- Identified LTI models, such as `idtf`, `idss`, or `idproc` models. For such models, the function can also plot confidence intervals and return standard deviations of the frequency response. (Using identified models requires System Identification Toolbox software.)

LineStylec – Line style, marker, and color

character vector | string

Line style, marker, and color, specified as a character vector or string containing symbols. The symbols can appear in any order. You do not need to specify all three characteristics (line style, marker, and color). For example, if you omit the line style and specify the marker, then the plot shows only the marker and no line.

Example: `'--or'` is a red dashed line with circle markers

Line Style	Description
-	Solid line
--	Dashed line
:	Dotted line
-.	Dash-dot line

Marker	Description
'o'	Circle
'+'	Plus sign
'*'	Asterisk
'.'	Point
'x'	Cross
'_'	Horizontal line
' '	Vertical line
's'	Square
'd'	Diamond
'^'	Upward-pointing triangle
'v'	Downward-pointing triangle
'>'	Right-pointing triangle
'<'	Left-pointing triangle
'p'	Pentagram
'h'	Hexagram

Color	Description
y	yellow
m	magenta
c	cyan
r	red
g	green
b	blue
w	white
k	black

w — Frequencies`{wmin,wmax}` | vector

Frequencies at which to compute and plot SV of the frequency response, specified as the cell array `{wmin,wmax}` or as a vector of frequency values.

- If `w` is a cell array of the form `{wmin,wmax}`, then the function plots the SV at frequencies ranging between `wmin` and `wmax`.
- If `w` is a vector of frequencies, then the function plots the SV at each specified frequency. For example, use `logspace` to generate a row vector with logarithmically spaced frequency values.

Specify frequencies in units of `rad/TimeUnit`, where `TimeUnit` is the `TimeUnit` property of the model.

type — Option to plot modified singular values

1 | 2 | 3

Option to plot modified singular values, specified as one of the following options:

- 1 to plot the SV of the frequency response H^{-1} , where H is the frequency response of `sys`.
- 2 to plot the SV of the frequency response $I+H$.
- 3 to plot the SV of the frequency response $I+H^{-1}$.

You can only use the `type` argument for *square systems*, that is, systems that have the same number of inputs and outputs.

AX — Target axes

Axes object

Target axes, specified as an Axes object. If you do not specify the axes and if the current axes are Cartesian axes, then `sigmaplot` plots on the current axes.

plotoptions — Sigma plot options set`SigmaPlotOptions` object

Sigma plot options set, specified as a `SigmaPlotOptions` object. You can use this option set to customize the SV plot appearance. Use `sigmaoptions` to create the option set. Settings you specify in `plotoptions` overrides the preference settings in the MATLAB session in which you run `sigmaplot`. Therefore, `plotoptions` is useful when you want to write a script to generate multiple plots that look the same regardless of the local preferences.

For the list of available options, see `sigmaoptions`.

Output Arguments**h — Plot handle**

handle object

Plot handle, returned as a handle object. Use the handle `h` to get and set the properties of the SV plot using `getoptions` and `setoptions`. For the list of available options, see the *Properties and Values Reference* section in “Customizing Response Plots from the Command Line”.

Version History

Introduced before R2006a

See Also

getoptions | setoptions | sigma | sigmaoptions

Topics

“Customizing Response Plots from the Command Line”

sisoinit

Configure Control System Designer at startup

Syntax

```
init_config = sisoinit(config)
```

Description

`init_config = sisoinit(config)` returns a template `init_config` for initializing the **Control System Designer** with one of the following control system configurations:

Configuration 1

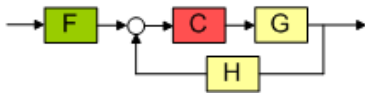

Configuration 2

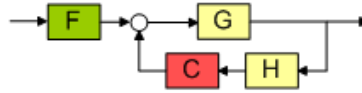

Configuration 3

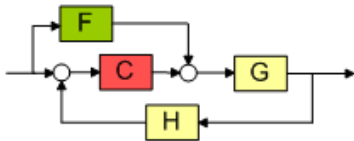

Configuration 4

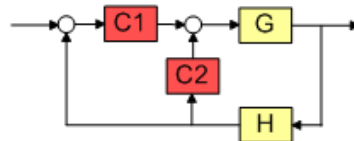

Configuration 5

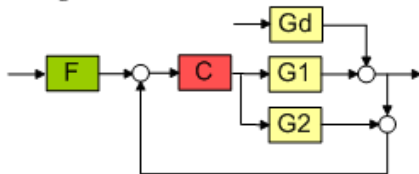

Configuration 6

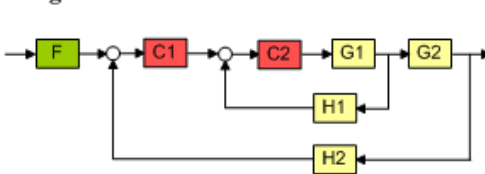

For more information about the control system configurations supported by the **Control System Designer**, see “Feedback Control Architectures”.

For each configuration, you can specify the plant model G and the sensor dynamics H , initialize the compensator C and prefilter F , and configure the open-loop and closed-loop views by specifying the corresponding fields of the structure `init_config`. Then you can start the **Control System Designer** in the specified configuration using `controlSystemDesigner(init_config)`.

Output argument `init_config` is an object with properties. The following tables list the block and loop properties.

Block Properties

Block	Properties	Values
F	Name	Character vector
	Description	Character vector
	Value	LTI object
G	Name	Character vector
	Value	<ul style="list-style-type: none"> LTI object Row or column array of LTI objects. If the sensor H is also an array of LTI objects, the lengths of G and H must match.
H	Name	Character vector
	Value	<ul style="list-style-type: none"> LTI object Row or column array of LTI objects. If the plant G is also an array of LTI objects, the lengths of H and G must match.
C	Name	Character vector
	Description	Character vector
	Value	LTI object

Loop Properties

Loops	Properties	Values
OL1	Name	Character vector
	Description	Character vector
	View	'rlocus' 'bode'
CL1	Name	Character vector
	Description	Character vector
	View	'bode'

Examples

Initialize Control System Designer

Create an initialization template for configuration 2, with the compensator in the feedback path.

```
T = sisoinit(2);
```

Specify the fixed plant model.

```
T.G.Value = tf(1, [1 1]);
```

Specify an initial compensator value.

```
T.C.Value = tf(1,[1 2]);
```

Open a root locus Editor and Nichols editor for tuning the open-loop response.

```
T.OL1.View = {'rlocus', 'nichols'};
```

Open Control System Designer using the specified configuration settings.

```
controlSystemDesigner(T)
```

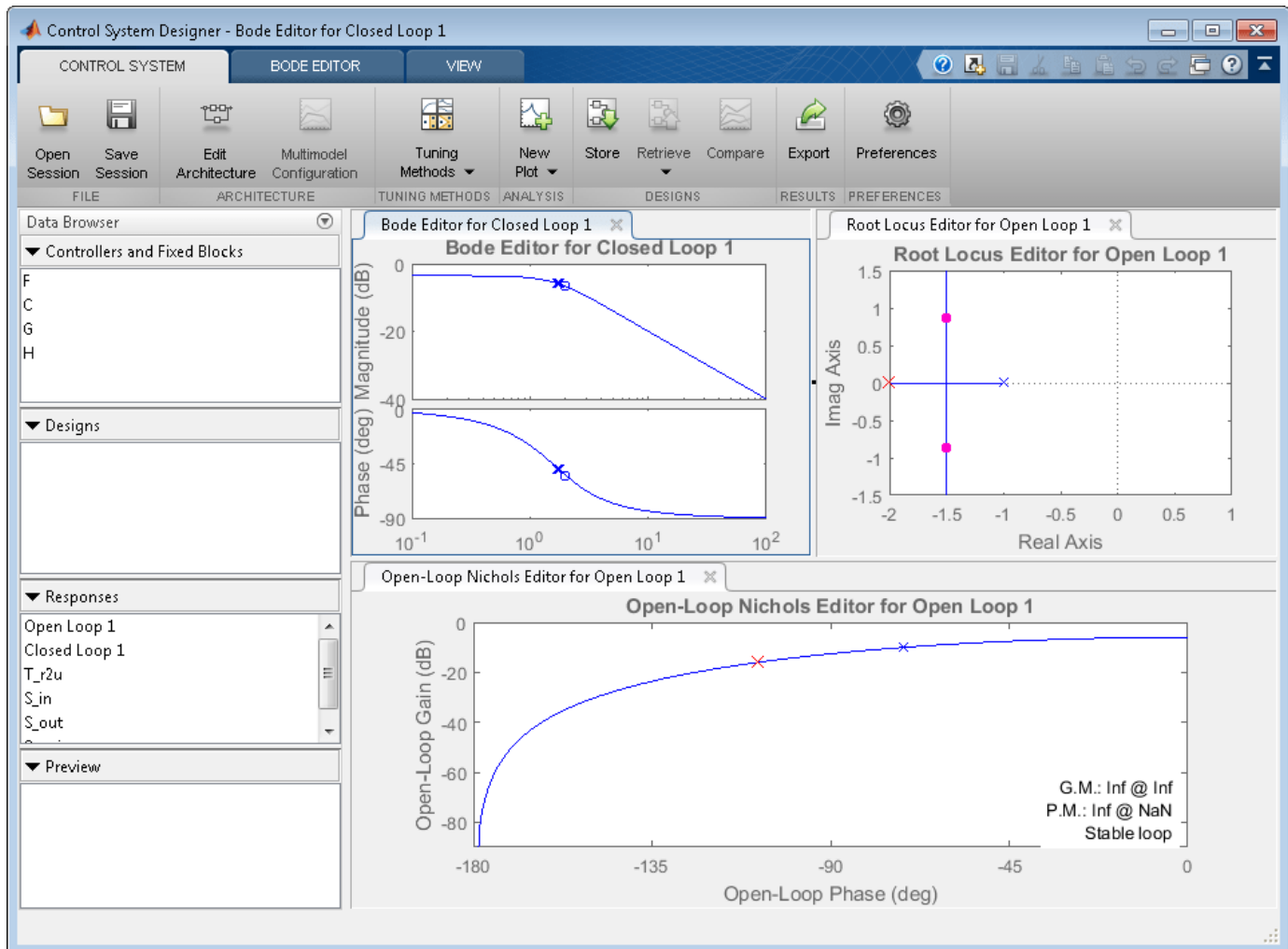

By default, the template for configuration 2 also opens a Bode editor for tuning the closed-loop response.

Initialize Control System Designer Using Array of Plant Models

Specify a configuration template.

```
initconfig = sisoinit(2);
```

Specify model parameters.

```
m = 3;  
b = 0.5;  
k = 8:1:10;  
T = 0.1:.05:.2;
```

Create an array of LTI objects to model variations in plant G.

```
for ct = 1:length(k);  
    G(:,:,ct) = tf(1,[m,b,k(ct)]);  
end
```

Assign G to the initial configuration.

```
initconfig.G.Value = G;
```

Specify initial compensator value.

```
initconfig.C.Value = tf(1,[1 2]);
```

Use a graphical Bode editor to tune the open-loop response.

```
initconfig.OL1.View = {'bode'};
```

Open **Control System Designer** using the specified configuration settings.

```
controlSystemDesigner(initconfig)
```

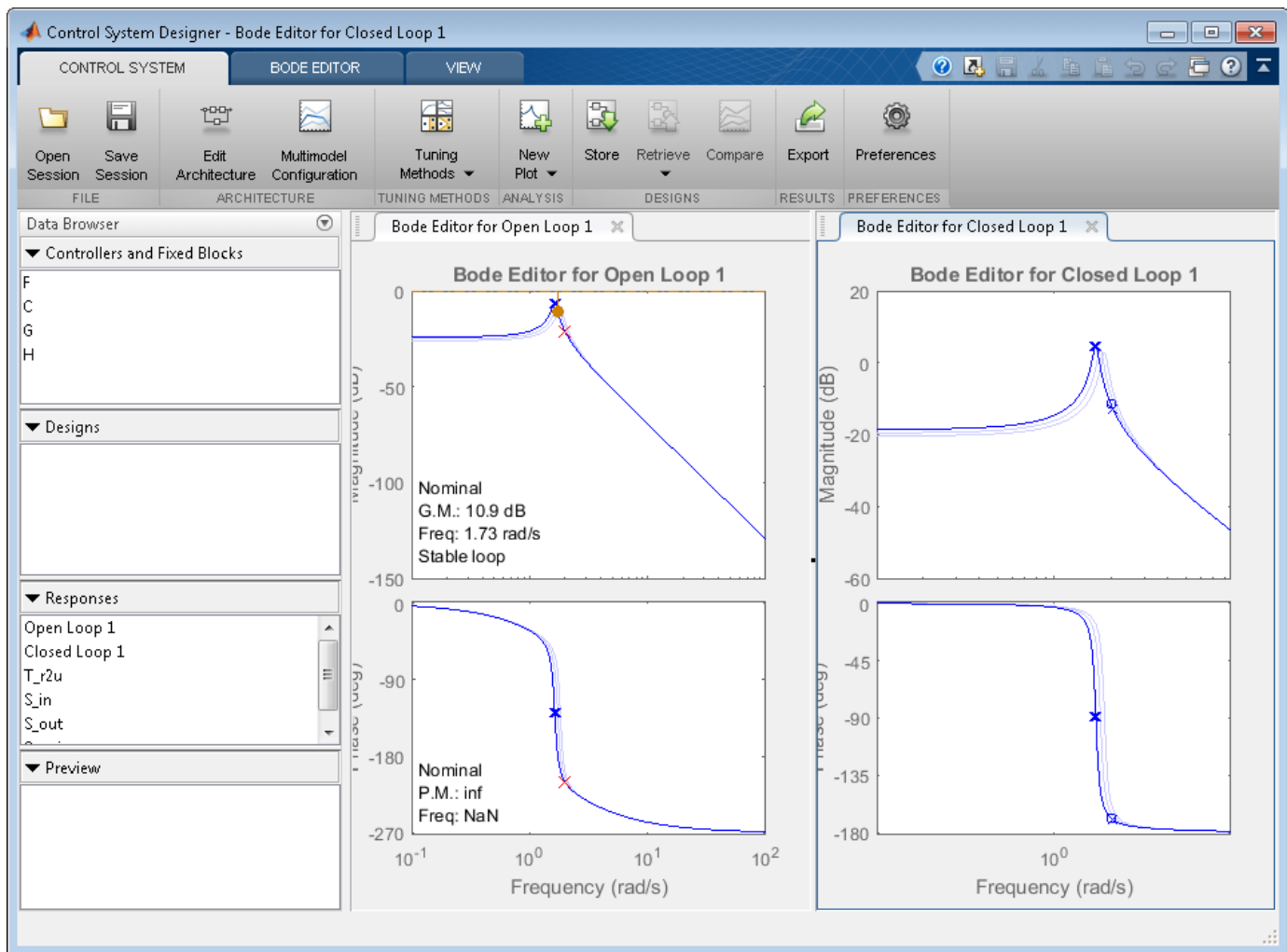

By default, the template for configuration 2 also opens a Bode editor for tuning the closed-loop response.

Version History

Introduced in R2006a

See Also

Control System Designer

Topics

“Feedback Control Architectures”

“Programmatically Initializing the Control System Designer”

“Multimodel Control Design”

size

Query output/input/array dimensions of input-output model and number of frequencies of FRD model

Syntax

```
size(sys)
d = size(sys)
Ny = size(sys,1)
Nu = size(sys,2)
Sk = size(sys,2+k)
Nf = size(sys,'frequency')
```

Description

When invoked without output arguments, `size(sys)` returns a description of type and the input-output dimensions of `sys`. If `sys` is a model array, the array size is also described. For identified models, the number of free parameters is also displayed. The lengths of the array dimensions are also included in the response to `size` when `sys` is a model array.

`d = size(sys)` returns:

- The row vector `d = [Ny Nu]` for a single dynamic model `sys` with `Ny` outputs and `Nu` inputs
- The row vector `d = [Ny Nu S1 S2 ... Sp]` for an `S1`-by-`S2`-by-...-by-`Sp` array of dynamic models with `Ny` outputs and `Nu` inputs

`Ny = size(sys,1)` returns the number of outputs of `sys`.

`Nu = size(sys,2)` returns the number of inputs of `sys`.

`Sk = size(sys,2+k)` returns the length of the `k`-th array dimension when `sys` is a model array.

`Nf = size(sys,'frequency')` returns the number of frequencies when `sys` is a frequency response data model. This is the same as the length of `sys.frequency`.

Examples

Query Dimensions of Model Array

Create a 3-by-1 model array of random state-space models with 3 outputs, 2 inputs, and 5 states.

```
sys = rss(5,3,2,3);
```

Verify the size of the model array.

```
size(sys)
```

```
3x1 array of state-space models.
Each model has 3 outputs, 2 inputs, and 5 states.
```

Query Dimensions of Identified Model

Create a 2-input 2-output continuous-time process model with identifiable parameters.

```
type = {'p1d', 'p2'; 'p3uz', 'p0'};  
sys = idproc(type);
```

Each element of the `type` cell array describes the model structure for the corresponding input-output pair.

Query the input-output dimensions and number of free parameters in the model.

```
size(sys)
```

Process model with 2 outputs, 2 inputs and 12 free parameters.

Version History

Introduced before R2006a

See Also

`isempty` | `issiso` | `ndims`

sminreal

Structural pole/zero cancellations

Syntax

```
msys = sminreal(sys)
```

Description

`msys = sminreal(sys)` eliminates the states of the state-space model `sys` that don't affect the input/output response. All of the states of the resulting state-space model `msys` are also states of `sys` and the input/output response of `msys` is equivalent to that of `sys`.

sminreal eliminates only structurally non minimal states, i.e., states that can be discarded by looking only at hard zero entries in the *A*, *B*, and *C* matrices. Such structurally nonminimal states arise, for example, when linearizing a Simulink model that includes some unconnected state-space or transfer function blocks.

Examples

Suppose you concatenate two SS models, `sys1` and `sys2`.

```
sys = [sys1,sys2];
```

This operation is depicted in the diagram below.

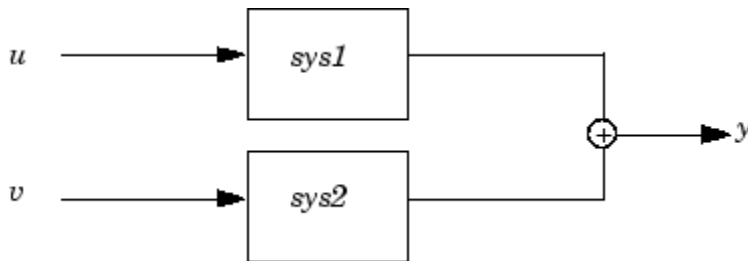

If you extract the subsystem `sys1` from `sys`, with

```
sys(1,1)
```

all of the states of `sys`, including those of `sys2` are retained. To eliminate the unobservable states from `sys2`, while retaining the states of `sys1`, type

```
sminreal(sys(1,1))
```

Tips

The model resulting from `sminreal(sys)` is not necessarily minimal, and may have a higher order than one resulting from `minreal(sys)`. However, `sminreal(sys)` retains the state structure of `sys`, while, in general, `minreal(sys)` does not.

Alternative Functionality

App

Model Reducer

Live Editor Task

Reduce Model Order

Version History

Introduced before R2006a

See Also

minreal | **Model Reducer** | **Reduce Model Order**

Topics

"Pole-Zero Simplification"

"Model Reduction Basics"

sparss

Sparse first-order state-space model

Description

Use `sparss` to represent sparse descriptor state-space models using matrices obtained from your finite element analysis (FEA) package. FEA involves the concept of dynamic substructuring where a mechanical system is partitioned into components that are modeled separately. These components are then coupled using rigid or semi-rigid physical interfaces that express consistency of displacements and equilibrium of internal forces. The resultant matrices from this type of modeling are quite large with a sparse pattern. Hence, using `sparss` is an efficient way to represent such large sparse state-space models in MATLAB to perform linear analysis. You can also use `sparss` to convert a second-order `mechss` model object to a `sparss` object.

You can use `sparss` model objects to represent SISO or MIMO state-space models in continuous time or discrete time. In continuous time, a first-order sparse state-space model is represented in the following form:

$$E \frac{dx}{dt} = A x(t) + B u(t)$$
$$y(t) = C x(t) + D u(t)$$

Here, x , u and y represent the states, inputs and outputs respectively, while A , B , C , D and E are the state-space matrices. The `sparss` object represents a state-space model in MATLAB storing sparse matrices A , B , C , D and E along with other information such as sample time, names and delays specific to the inputs and outputs.

You can use a `sparss` object to:

- Perform time-domain and frequency-domain response analysis.
- Specify signal-based connections with other LTI models.
- Transform models between continuous-time and discrete-time representations.

For more information, see “Sparse Model Basics”.

Creation

Syntax

```
sys = sparss(A,B,C,D,E)
sys = sparss(A,B,C,D,E,ts)
sys = sparss(D)
sys = sparss( ___,Name,Value)

sys = sparss(ltiSys)
```

Description

`sys = spars(A, B, C, D, E)` creates a continuous-time first-order sparse state-space model object of the following form:

$$E \frac{dx}{dt} = A x(t) + B u(t)$$

$$y(t) = C x(t) + D u(t)$$

For instance, consider a plant with N_x states, N_y outputs, and N_u inputs. The first-order state-space matrices are:

- A is the sparse state matrix with N_x -by- N_x real- or complex-values.
- B is the sparse input-to-state matrix with N_x -by- N_u real- or complex-values.
- C is the sparse state-to-output matrix with N_y -by- N_x real- or complex-values.
- D is the sparse gain or input-to-output matrix with N_y -by- N_u real- or complex-values.
- E is the sparse mass matrix with the same size as matrix A . When E is omitted, `spars` populates E with an identity matrix.

`sys = spars(A, B, C, D, E, ts)` creates a discrete-time sparse state-space model with sample time `ts` with the form:

$$E x[k + 1] = A x[k] + B u[k]$$

$$y[k] = C x[k] + D u[k]$$

To leave the sample time unspecified, set `ts` to `-1`. When E is an identity matrix, you can set E as `[]` or omit E as long as A is not a scalar.

`sys = spars(D)` creates a sparse state-space model that represents the static gain, D . The output state-space model is equivalent to `spars([], [], [], D, [])`.

`sys = spars(___, Name, Value)` sets properties of the first-order sparse state-space model using one or more name-value pair arguments. Use this syntax with any of the previous input-argument combinations.

`sys = spars(ltiSys)` converts the dynamic system model `ltiSys` to a first-order sparse state-space model.

Input Arguments

A — State Matrix

N_x -by- N_x sparse matrix

State matrix, specified as an N_x -by- N_x sparse matrix, where N_x is the number of states. This input sets the value of property `A`.

B — Input-to-state matrix

N_x -by- N_u sparse matrix

Input-to-state matrix, specified as an N_x -by- N_u sparse matrix, where N_x is the number of states and N_u is the number of inputs. This input sets the value of property `B`.

C — State-to-output matrix

N_y -by- N_x sparse matrix

State-to-output matrix, specified as an N_y -by- N_x sparse matrix, where N_x is the number of states and N_y is the number of outputs. This input sets the value of property C.

D — Input-to-output matrix

N_y -by- N_u sparse matrix

Input-to-output matrix, specified as an N_y -by- N_u sparse matrix, where N_y is the number of outputs and N_u is the number of inputs. This input sets the value of property D.

E — Mass matrix

N_x -by- N_x sparse matrix

Mass matrix, specified as an N_x -by- N_x sparse matrix, where N_x is the number of states. This input sets the value of property E.

ts — Sample time

scalar

Sample time, specified as a scalar. For more information see the Ts property.

ltiSys — Dynamic system to convert to first-order sparse state-space form

dynamic system model | model array

Dynamic system to convert to first-order sparse state-space form, specified as a SISO or MIMO dynamic system model or array of dynamic system models. Dynamic systems that you can convert include:

- Continuous-time or discrete-time numeric LTI models, such as `mechss`, `tf`, `zpk`, `ss` or `pid` models.

Output Arguments**sys — Output system model**

`sparss` model object

Output system model, returned as a `sparss` model object.

Properties**A — State matrix**

N_x -by- N_x sparse matrix

State matrix, specified as an N_x -by- N_x sparse matrix, where N_x is the number of states.

B — Input-to-state matrix

N_x -by- N_u sparse matrix

Input-to-state matrix, specified as an N_x -by- N_u sparse matrix, where N_x is the number of states and N_u is the number of inputs.

C — State-to-output matrix

N_y -by- N_x sparse matrix

State-to-output matrix, specified as an N_y -by- N_x sparse matrix, where N_x is the number of states and N_y is the number of outputs.

D — Input-to-output matrix

Ny-by-Nu sparse matrix

Input-to-output matrix, specified as an Ny-by-Nu sparse matrix, where Ny is the number of outputs and Nu is the number of inputs. D is also called as the static gain matrix which represents the ratio of the output to the input under steady state condition.

E — Mass matrix

Nx-by-Nx sparse matrix

Mass matrix, specified as a Nx-by-Nx sparse matrix. E is the same size as A.

Differential algebraic equations (DAEs) are characterized by their *differential index*, which is a measure of their singularity. A linear DAE is of index ≤ 1 if it can be transformed by congruence to the following form with E_{11} and A_{22} being invertible matrices.

$$\begin{aligned} E_{11}\dot{x}_1 &= A_{11}x_1 + A_{12}x_2 + B_1u \\ 0 &= A_{21}x_1 + A_{22}x_2 + B_2u \end{aligned}$$

The index of the DAE is 0 if x_2 is empty. The index is 1 if x_2 is not empty. In other words, a linear DAE has structural index ≤ 1 if it can be brought to the above form by row and column permutations of A and E. Some functionality, such as computing the impulse response of the system, is limited to DAEs with structural index less than 1.

For more information on DAE index, see “Solve Differential Algebraic Equations (DAEs)”.

StateInfo — State partition information

structure array

State partition information containing state vector components, interfaces between components and internal signal connecting components, specified as a structure array with the following fields:

- **Type** — Type includes component, signal or physical interface
- **Name** — Name of the component, signal or physical interface
- **Size** — Number of states or degrees of freedom in the partition

You can view the partition information of the sparse state-space model using `showStateInfo`. You can also sort and order the partitions in your sparse model using `xsort`.

SolverOptions — Options for model analysis

structure

Options for model analysis, specified as a structure with the following fields:

- **UseParallel** — Set this option `true` to enable parallel computing and `false` to disable it. Parallel computing is disabled by default. The `UseParallel` option requires a Parallel Computing Toolbox license.
- **DAESolver** — Use this option to select the type of Differential Algebraic Equation (DAE) solver. The available DAE solvers are:
 - `'trbdf2'` — Fixed-step solver with an accuracy of $o(h^2)$, where h is the step size.[1]
 - `'trbdf3'` — Fixed-step solver with an accuracy of $o(h^3)$, where h is the step size.

Reducing the step size increases accuracy and extends the frequency range where numerical damping is negligible. 'trbdf3' is about 50% more computationally intensive than 'trbdf2'

InternalDelay — Internal delays in the model

vector

Internal delays in the model, specified as a vector. Internal delays arise, for example, when closing feedback loops on systems with delays, or when connecting delayed systems in series or parallel. For more information about internal delays, see “Closing Feedback Loops with Time Delays”.

For continuous-time models, internal delays are expressed in the time unit specified by the `TimeUnit` property of the model. For discrete-time models, internal delays are expressed as integer multiples of the sample time `Ts`. For example, `InternalDelay = 3` means a delay of three sampling periods.

You can modify the values of internal delays using the property `InternalDelay`. However, the number of entries in `sys.InternalDelay` cannot change, because it is a structural property of the model.

InputDelay — Input delay

0 (default) | scalar | Nu-by-1 vector

Input delay for each input channel, specified as one of the following:

- Scalar — Specify the input delay for a SISO system or the same delay for all inputs of a multi-input system.
- Nu-by-1 vector — Specify separate input delays for input of a multi-input system, where Nu is the number of inputs.

For continuous-time systems, specify input delays in the time unit specified by the `TimeUnit` property. For discrete-time systems, specify input delays in integer multiples of the sample time, `Ts`.

For more information, see “Time Delays in Linear Systems”.

OutputDelay — Output delay

0 (default) | scalar | Ny-by-1 vector

Output delay for each output channel, specified as one of the following:

- Scalar — Specify the output delay for a SISO system or the same delay for all outputs of a multi-output system.
- Ny-by-1 vector — Specify separate output delays for output of a multi-output system, where Ny is the number of outputs.

For continuous-time systems, specify output delays in the time unit specified by the `TimeUnit` property. For discrete-time systems, specify output delays in integer multiples of the sample time, `Ts`.

For more information, see “Time Delays in Linear Systems”.

Ts — Sample time

0 (default) | positive scalar | -1

Sample time, specified as:

- 0 for continuous-time systems.

- A positive scalar representing the sampling period of a discrete-time system. Specify T_s in the time unit specified by the `TimeUnit` property.
- -1 for a discrete-time system with an unspecified sample time.

Note Changing T_s does not discretize or resample the model. To convert between continuous-time and discrete-time representations, use `c2d` and `d2c`. To change the sample time of a discrete-time system, use `d2d`.

TimeUnit — Time variable units

'seconds' (default) | 'nanoseconds' | 'microseconds' | 'milliseconds' | 'minutes' | 'hours' | 'days' | 'weeks' | 'months' | 'years' | ...

Time variable units, specified as one of the following:

- 'nanoseconds'
- 'microseconds'
- 'milliseconds'
- 'seconds'
- 'minutes'
- 'hours'
- 'days'
- 'weeks'
- 'months'
- 'years'

Changing `TimeUnit` has no effect on other properties, but changes the overall system behavior. Use `chgTimeUnit` to convert between time units without modifying system behavior.

InputName — Input channel names

'' (default) | character vector | cell array of character vectors

Input channel names, specified as one of the following:

- A character vector, for single-input models.
- A cell array of character vectors, for multi-input models.
- '', no names specified, for any input channels.

Alternatively, you can assign input names for multi-input models using automatic vector expansion. For example, if `sys` is a two-input model, enter the following:

```
sys.InputName = 'controls';
```

The input names automatically expand to {'controls(1)'; 'controls(2)'}

You can use the shorthand notation `u` to refer to the `InputName` property. For example, `sys.u` is equivalent to `sys.InputName`.

Use `InputName` to:

- Identify channels on model display and plots.
- Extract subsystems of MIMO systems.
- Specify connection points when interconnecting models.

InputUnit — Input channel units

' ' (default) | character vector | cell array of character vectors

Input channel units, specified as one of the following:

- A character vector, for single-input models.
- A cell array of character vectors, for multi-input models.
- ' ', no units specified, for any input channels.

Use `InputUnit` to specify input signal units. `InputUnit` has no effect on system behavior.

InputGroup — Input channel groups

structure

Input channel groups, specified as a structure. Use `InputGroup` to assign the input channels of MIMO systems into groups and refer to each group by name. The field names of `InputGroup` are the group names and the field values are the input channels of each group. For example, enter the following to create input groups named `controls` and `noise` that include input channels 1 and 2, and 3 and 5, respectively.

```
sys.InputGroup.controls = [1 2];  
sys.InputGroup.noise = [3 5];
```

You can then extract the subsystem from the `controls` inputs to all outputs using the following.

```
sys(:, 'controls')
```

By default, `InputGroup` is a structure with no fields.

OutputName — Output channel names

' ' (default) | character vector | cell array of character vectors

Output channel names, specified as one of the following:

- A character vector, for single-output models.
- A cell array of character vectors, for multi-output models.
- ' ', no names specified, for any output channels.

Alternatively, you can assign output names for multi-output models using automatic vector expansion. For example, if `sys` is a two-output model, enter the following.

```
sys.OutputName = 'measurements';
```

The output names automatically expand to `{'measurements(1)'; 'measurements(2)'}`.

You can also use the shorthand notation `y` to refer to the `OutputName` property. For example, `sys.y` is equivalent to `sys.OutputName`.

Use `OutputName` to:

- Identify channels on model display and plots.
- Extract subsystems of MIMO systems.
- Specify connection points when interconnecting models.

OutputUnit — Output channel units

' ' (default) | character vector | cell array of character vectors

Output channel units, specified as one of the following:

- A character vector, for single-output models.
- A cell array of character vectors, for multi-output models.
- ' ', no units specified, for any output channels.

Use `OutputUnit` to specify output signal units. `OutputUnit` has no effect on system behavior.

OutputGroup — Output channel groups

structure

Output channel groups, specified as a structure. Use `OutputGroup` to assign the output channels of MIMO systems into groups and refer to each group by name. The field names of `OutputGroup` are the group names and the field values are the output channels of each group. For example, create output groups named `temperature` and `measurement` that include output channels 1, and 3 and 5, respectively.

```
sys.OutputGroup.temperature = [1];
sys.OutputGroup.measurement = [3 5];
```

You can then extract the subsystem from all inputs to the measurement outputs using the following.

```
sys('measurement',:)
```

By default, `OutputGroup` is a structure with no fields.

Notes — User-specified text

{ } (default) | character vector | cell array of character vectors

User-specified text that you want to associate with the system, specified as a character vector or cell array of character vectors. For example, `'System is MIMO'`.

UserData — User-specified data

[] (default) | any MATLAB data type

User-specified data that you want to associate with the system, specified as any MATLAB data type.

Name — System name

' ' (default) | character vector

System name, specified as a character vector. For example, `'system_1'`.

SamplingGrid — Sampling grid for model arrays

structure array

Sampling grid for model arrays, specified as a structure array.

Use `SamplingGrid` to track the variable values associated with each model in a model array.

Set the field names of the structure to the names of the sampling variables. Set the field values to the sampled variable values associated with each model in the array. All sampling variables must be numeric scalars, and all arrays of sampled values must match the dimensions of the model array.

For example, you can create an 11-by-1 array of linear models, `sysarr`, by taking snapshots of a linear time-varying system at times `t = 0:10`. The following code stores the time samples with the linear models.

```
sysarr.SamplingGrid = struct('time',0:10)
```

Similarly, you can create a 6-by-9 model array, `M`, by independently sampling two variables, `zeta` and `w`. The following code maps the (`zeta,w`) values to `M`.

```
[zeta,w] = ndgrid(<6 values of zeta>,<9 values of w>)
M.SamplingGrid = struct('zeta',zeta,'w',w)
```

By default, `SamplingGrid` is a structure with no fields.

Object Functions

The following lists show functions you can use with `spars` model objects.

Modeling

<code>mechss</code>	Sparse second-order state-space model
<code>getx0</code>	Map initial conditions from a <code>mechss</code> object to a <code>spars</code> object
<code>full</code>	Convert sparse models to dense storage
<code>imp2exp</code>	Convert implicit linear relationship to explicit input-output relation
<code>inv</code>	Invert models
<code>getDelayModel</code>	State-space representation of internal delays

Data Access

<code>sparsdata</code>	Access first-order sparse state-space model data
<code>mechssdata</code>	Access second-order sparse state-space model data
<code>showStateInfo</code>	State vector map for sparse model
<code>spy</code>	Visualize sparsity pattern of a sparse model

Model Transformation

<code>c2d</code>	Convert model from continuous to discrete time
<code>d2c</code>	Convert model from discrete to continuous time
<code>d2d</code>	Resample discrete-time model

Time and Frequency Response

<code>step</code>	Step response plot of dynamic system; step response data
<code>impulse</code>	Impulse response plot of dynamic system; impulse response data
<code>initial</code>	System response to initial states of state-space model
<code>lsim</code>	Plot simulated time response of dynamic system to arbitrary inputs; simulated response data
<code>bode</code>	Bode plot of frequency response, or magnitude and phase data
<code>nyquist</code>	Nyquist plot of frequency response
<code>nichols</code>	Nichols chart of frequency response

<code>sigma</code>	Singular value plot of dynamic system
<code>passiveplot</code>	Compute or plot passivity index as function of frequency
<code>dcgain</code>	Low-frequency (DC) gain of LTI system
<code>evalfr</code>	Evaluate system response at specific frequency
<code>freqresp</code>	Evaluate system response over a grid of frequencies

Model Interconnection

<code>interface</code>	Specify physical connections between components of mechss model
<code>xsort</code>	Sort states based on state partition
<code>feedback</code>	Feedback connection of multiple models
<code>parallel</code>	Parallel connection of two models
<code>append</code>	Group models by appending their inputs and outputs
<code>connect</code>	Block diagram interconnections of dynamic systems
<code>lft</code>	Generalized feedback interconnection of two models (Redheffer star product)
<code>series</code>	Series connection of two models

Examples

Continuous-Time Sparse First-Order Model

For this example, consider `sparseFOContinuous.mat` which contains sparse matrices for a continuous-time sparse first-order state-space model.

Extract the sparse matrices from `sparseFOContinuous.mat`.

```
load('sparseFOContinuous.mat','A','B','C','D','E');
```

Create the `sparss` model object.

```
sys = sparss(A,B,C,D,E)
```

Sparse continuous-time state-space model with 1 outputs, 1 inputs, and 199 states.

Use `"spy"` and `"showStateInfo"` to inspect model structure.

Type `"properties('sparss')"` for a list of model properties.

Type `"help sparssOptions"` for available solver options for this model.

The output `sys` is a continuous-time `sparss` model object containing with 199 states, 1 input and 1 output.

You can use the `spy` command to visualize the sparsity of the `sparss` model object.

```
spy(sys)
```

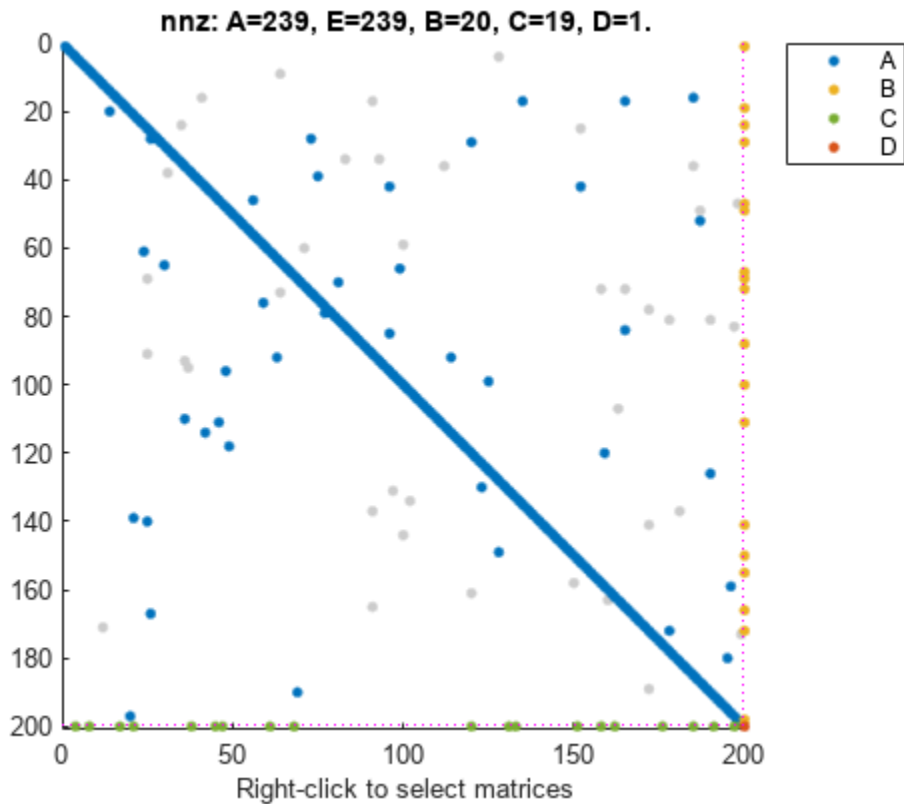

Discrete-Time Sparse First-Order Model

For this example, consider `sparseFODiscrete.mat` which contains sparse matrices for a discrete-time sparse first-order state-space model.

Extract the sparse matrices from `sparseFODiscrete.mat`.

```
load('sparseFODiscrete.mat', 'A', 'B', 'C', 'D', 'E', 'ts');
```

Create the `spars` model object.

```
sys = spars(A,B,C,D,E,ts)
```

Sparse discrete-time state-space model with 1 outputs, 1 inputs, and 398 states.

Use `spy` and `showStateInfo` to inspect model structure.

Type `properties('spars')` for a list of model properties.

Type `help sparsOptions` for available solver options for this model.

The output `sys` is a discrete-time `spars` model object containing with 398 states, 1 input and 1 output.

You can use the `spy` command to visualize the sparsity of the `spars` model object.

```
spy(sys)
```

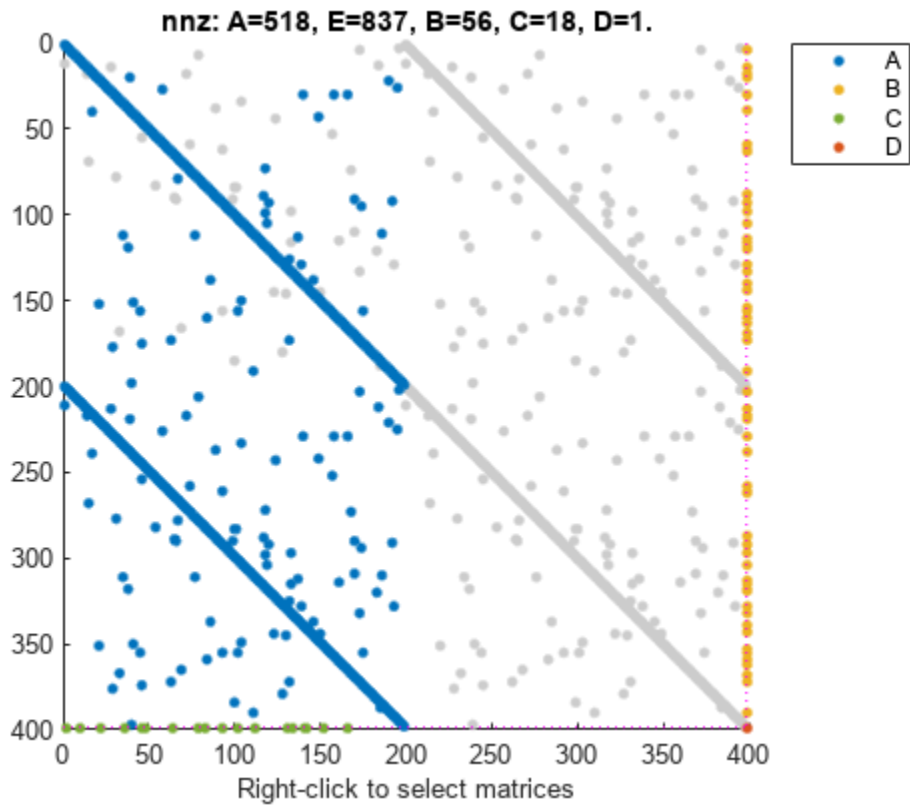

You can also view model properties of the sparss model object.

```
properties('sparss')
```

Properties for class sparss:

```
A
B
C
D
E
Scaled
StateInfo
SolverOptions
InternalDelay
InputDelay
OutputDelay
InputName
InputUnit
InputGroup
OutputName
OutputUnit
OutputGroup
Notes
UserData
Name
Ts
```

```
TimeUnit  
SamplingGrid
```

MIMO Static Gain Sparse First-Order Model

Create a static gain MIMO sparse first-order state-space model.

Consider the following three-input, two-output static gain matrix:

$$D = \begin{bmatrix} 1 & 5 & 7 \\ 6 & 3 & 9 \end{bmatrix}$$

Specify the gain matrix and create the static gain sparse first-order state-space model.

```
D = [1,5,7;6,3,9];  
sys = sparss(D);  
size(sys)
```

Sparse state-space model with 2 outputs, 3 inputs, and 0 states.

Convert Second-Order Sparse Model to First-Order Sparse Model Representation

For this example, consider `mechssModel.mat` that contains a `mechss` model object `ltiSys`.

Load the `mechss` model object from `mechssModel.mat`.

```
load('mechssModel.mat','ltiSys');  
ltiSys
```

Sparse continuous-time second-order model with 1 outputs, 1 inputs, and 872 degrees of freedom.

Use "spy" and "showStateInfo" to inspect model structure.
Type "properties('mechss')" for a list of model properties.
Type "help mechssOptions" for available solver options for this model.

Use the `sparss` command to convert to first-order sparse representation.

```
sys = sparss(ltiSys)
```

Sparse continuous-time state-space model with 1 outputs, 1 inputs, and 1744 states.

Use "spy" and "showStateInfo" to inspect model structure.
Type "properties('sparss')" for a list of model properties.
Type "help sparssOptions" for available solver options for this model.

The resultant `sparss` model object `sys` has exactly double the number of states than the `mechss` object `ltiSys` since the mass matrix `M` is full rank. If the mass matrix is not full rank then the number of states in the resultant `sparss` model when converting from a `mechss` model is between `n` and `2n`. Here, `n` is the number of nodes in the `mechss` model object.

Sparse First-Order Model in a Feedback Loop

For this example, consider `sparseF0Signal.mat` that contains a sparse first-order model. Define an actuator, sensor, and controller and connect them together with the plant in a feedback loop.

Load the sparse matrices and create the `spars` object.

```
load sparseF0Signal.mat
plant = spars(A,B,C,D,E, 'Name', 'Plant');
```

Next, create an actuator and sensor using transfer functions.

```
act = tf(1,[1 2 3], 'Name', 'Actuator');
sen = tf(1,[6 7], 'Name', 'Sensor');
```

Create a PID controller object for the plant.

```
con = pid(1,1,0.1,0.01, 'Name', 'Controller');
```

Use the `feedback` command to connect the plant, sensor, actuator, and controller in a feedback loop.

```
sys = feedback(sen*plant*act*con,1)
```

Sparse continuous-time state-space model with 1 outputs, 1 inputs, and 29 states.

Use `"spy"` and `"showStateInfo"` to inspect model structure.
Type `"properties('spars')`" for a list of model properties.
Type `"help sparsOptions"` for available solver options for this model.

The resultant system `sys` is a `spars` object since `spars` objects take precedence over `tf` and PID model object types.

Use `showStateInfo` to view the component and signal groups.

```
showStateInfo(sys)
```

The state groups are:

Type	Name	Size
-----	-----	-----
Component	Sensor	1
Component	Plant	20
Signal		1
Component	Actuator	2
Signal		1
Component	Controller	2
Signal		1
Signal		1

Use `xsort` to sort the components and signals, and then view the component and signal groups.

```
sysSort = xsort(sys);
showStateInfo(sysSort)
```

The state groups are:

Type	Name	Size
-----	-----	-----
Component	Sensor	1

Component	Plant	20
Component	Actuator	2
Component	Controller	2
Signal		4

Observe that the components are now ordered before the signal partition. The signals are now sorted and grouped together in a single partition.

You can also visualize the sparsity pattern of the resultant system using `spy`.

```
spy(sysSort)
```

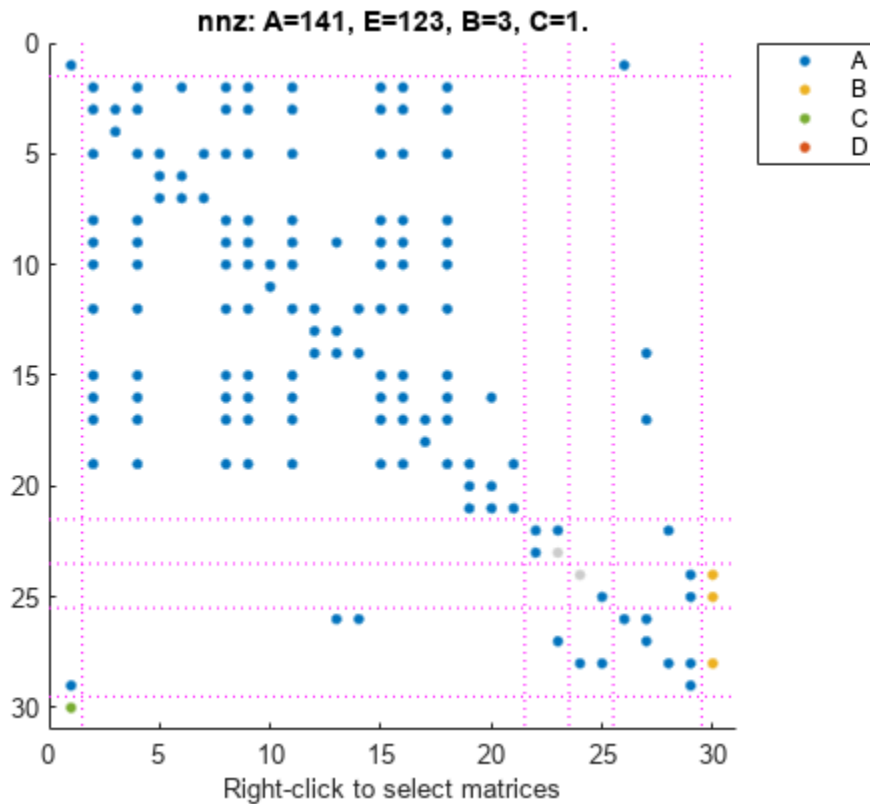

Version History

Introduced in R2020b

References

[1] M. Hosea and L. Shampine. "Analysis and implementation of TR-BDF2." *Applied Numerical Mathematics*, vol. 20, no. 1-2, pp. 21-37, 1996.

See Also

`sparssdata` | `mechss` | `showStateInfo` | `xsort` | `full` | `getx0` | `spy` | Descriptor State-Space

Topics

“Sparse Model Basics”

sparsdata

Access first-order sparse state-space model data

Syntax

```
[A,B,C,D,E] = sparsdata(sys)
[A,B,C,D,E,ts] = sparsdata(sys)
___ = sparsdata(sys,J1,...,JN)
```

Description

`[A,B,C,D,E] = sparsdata(sys)` returns the A, B, C, D, E matrices of the sparse state-space model `sys`. If `sys` is not a `spars` model, it is first converted to `spars` model form.

When your system has internal delays, `sparsdata` returns the matrices for `pade(sys,0)`, which involves feedback loops around the internal delays and the model is retained in differential algebraic equation (DAE) form to preserve sparsity. As a result, the size of matrices A and E are typically larger than the order of `sys`.

`[A,B,C,D,E,ts] = sparsdata(sys)` also returns the sample time `ts`.

`___ = sparsdata(sys,J1,...,JN)` extracts the data for the `J1,...,JN` entry in the model array `sys`.

Examples

Extract Continuous-Time Sparse First-Order State-Space Model Data

For this example, consider `sparseF0Data.mat` which contains a continuous-time `spars` model `sys1`.

Load the model `sys1` to the workspace and use `sparsdata` to extract the sparse matrices.

```
load('sparseF0Data.mat','sys1');
size(sys1)
```

Sparse state-space model with 1 outputs, 2 inputs, and 199 states.

```
[A,B,C,D,E] = sparsdata(sys1);
```

The matrices are returned as arrays of sparse doubles.

Extract Discrete-Time Sparse First-Order State-Space Model Data

For this example, consider `sparseF0Data.mat` which contains a discrete-time `spars` model `sys2`.

Load the model `sys2` to the workspace and use `sparsdata` to extract the sparse matrices.

```
load('sparseF0Data.mat','sys2');
size(sys2)
```

Sparse state-space model with 1 outputs, 1 inputs, and 235 states.

```
[A,B,C,D,E,ts] = sparssdata(sys2);
```

The matrices are returned as arrays of sparse doubles.

Extract Data from Specific Model in Sparse First-Order Model Array

For this example, extract sparse matrices for a specific sparse first-order state-space model contained in the 3x1 array of sparse first-order models `sys3`.

Load the data and extract the sparse matrices of the second model in the array.

```
load('sparseF0Data.mat','sys3');
size(sys3)
```

1x3 array of sparse state-space models.
Each model has 1 outputs, 3 inputs, and 671 states.

```
[A,B,C,D,E] = sparssdata(sys3,1,2);
```

Input Arguments

sys — Dynamic system

dynamic system model | model array

Dynamic system, specified as a SISO or MIMO dynamic system model, or an array of SISO or MIMO dynamic system models. Dynamic systems that you can use include continuous-time or discrete-time numeric LTI models such as `sparss`, `mechss`, `tf`, `ss` and `zpk` models.

If `sys` is not a `sparss` model, it is first converted to first-order sparse form using `sparss`. For more information on the format of sparse first-order state-space model data, see the `sparss` reference page.

J1, ..., JN — Indices of models in array whose data you want to access

positive integer

Indices of models in array whose data you want to access, specified as a positive integer. You can provide as many indices as there are array dimensions in `sys`. For example, if `sys` is a 4-by-5 array of sparse models, the following command accesses the data for entry (2,3) in the array.

```
[A,B,C,D,E] = sparssdata(sys,2,3);
```

Output Arguments

A — State matrix

N_x -by- N_x sparse matrix

State matrix, returned as an N_x -by- N_x sparse matrix where, N_x is the number of states.

B — Input-to-state matrix

N_x-by- N_u sparse matrix

Input-to-state matrix, returned as an N_x -by- N_u sparse matrix where N_x is the number of states and N_u is the number of inputs.

C — State-to-output matrix

N_y-by- N_x sparse matrix

State-to-output matrix, returned as an N_y -by- N_x sparse matrix where N_x is the number of states and N_y is the number of outputs.

D — Input-to-output matrix

N_y-by- N_u sparse matrix

Input-to-output matrix, returned as an N_y -by- N_u sparse matrix where N_y is the number of outputs and N_u is the number of inputs. D is also called as the static gain matrix which represents the ratio of the output to the input under steady state condition.

E — Mass matrix

N_x-by- N_x sparse matrix

Mass matrix, returned as a N_x -by- N_x sparse matrix. E is the same size as A .

ts — Sample time

scalar

Sample time, returned as a scalar.

Version History

Introduced in R2020b

See Also

sparss

Topics

“Sparse Model Basics”

spectralfact

Spectral factorization of linear systems

Syntax

```
[G,S] = spectralfact(H)
[G,S] = spectralfact(F,R)
G = spectralfact(F,[])
```

Description

`[G,S] = spectralfact(H)` computes the spectral factorization:

$$H = G' * S * G$$

of an LTI model satisfying $H = H'$. In this factorization, S is a symmetric matrix and G is a square, stable, and minimum-phase system with unit (identity) feedthrough. G' is the conjugate of G , which has transfer function $G(-s)^T$ in continuous time, and $G(1/z)^T$ in discrete time.

`[G,S] = spectralfact(F,R)` computes the spectral factorization:

$$F' * R * F = G' * S * G$$

without explicitly forming $H = F' * R * F$. As in the previous syntax, S is a symmetric matrix and G is a square, stable, and minimum-phase system with unit feedthrough.

`G = spectralfact(F,[])` computes a stable, minimum-phase system G such that:

$$G' * G = F' * F.$$

Examples

Spectral Factorization of System

Consider the following system.

```
G0 = ss(zpk([-1 -5 1+2i 1-2i],[-100 1+2i 1-2i -10],1e3));
H = G0'*G0;
```

G_0 has a mix of stable and unstable dynamics. H is a self-conjugate system whose dynamics consist of the poles and zeros of G_0 and their reflections across the imaginary axis. Use spectral factorization to separate the stable poles and zeros into G and the unstable poles and zeros into G' .

```
[G,S] = spectralfact(H);
```

Confirm that G is stable and minimum phase, by checking that all its poles and zeros fall in the left half-plane ($\text{Re}(s) < 0$).

```
p = pole(G)
```

```
p = 4×1 complex
102 ×
```

```
-0.0100 + 0.0200i
-0.0100 - 0.0200i
-0.1000 + 0.0000i
-1.0000 + 0.0000i
```

```
z = zero(G)
```

```
z = 4×1 complex
```

```
-1.0000 + 2.0000i
-1.0000 - 2.0000i
-1.0000 + 0.0000i
-5.0000 + 0.0000i
```

G also has unit feedthrough.

```
G.D
```

```
ans = 1
```

Because H is SISO, S is a scalar. If H were MIMO, the dimensions of S would match the I/O dimensions of H.

```
S
```

```
S = 1000000
```

Confirm that G and S satisfy $H = G'SG$ by comparing the original system to the difference between the original and factored systems. `sigmaplot` throws a warning because the difference is very small.

```
Hf = G'*S*G;
sigmaplot(H,H-Hf)
```

Warning: The frequency response has poor relative accuracy. This may be because the response is

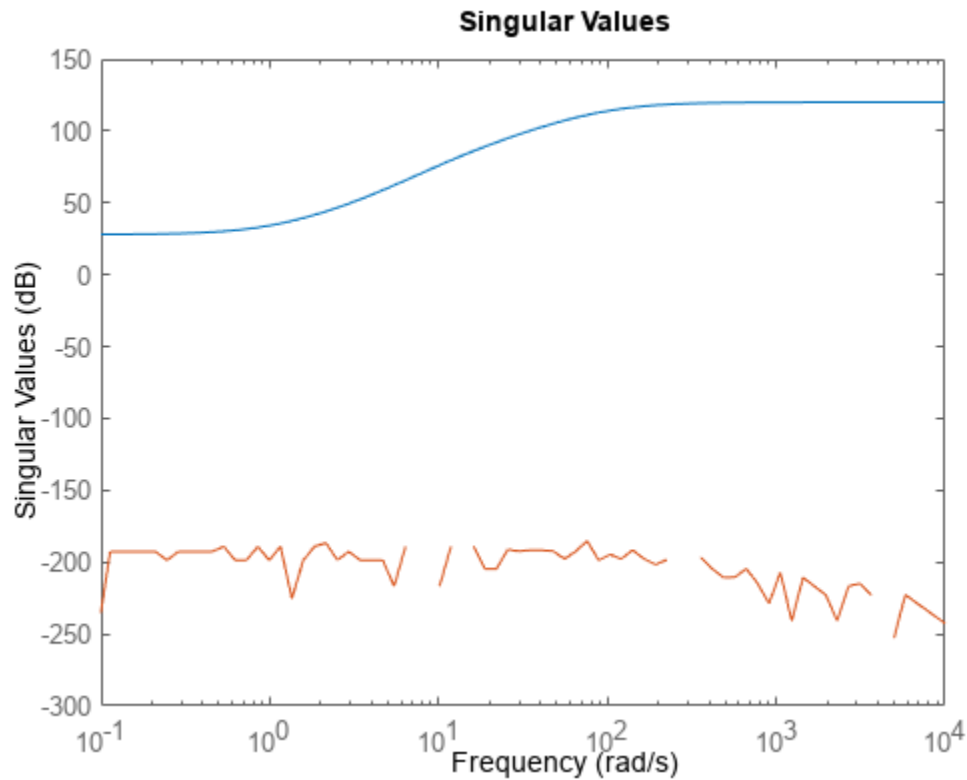

Spectral Factorization from Factored Form

Suppose that you have the following 2-output, 2-input state-space model, F .

$$\begin{aligned} A &= \begin{bmatrix} -1.1 & 0.37 \\ 0.37 & -0.95 \end{bmatrix}; \\ B &= \begin{bmatrix} 0.72 & 0.71 \\ 0 & -0.20 \end{bmatrix}; \\ C &= \begin{bmatrix} 0.12 & 1.40 \\ 1.49 & 1.41 \end{bmatrix}; \\ D &= \begin{bmatrix} 0.67 & 0.7172 \\ -1.2 & 0 \end{bmatrix}; \\ F &= \text{ss}(A, B, C, D); \end{aligned}$$

Suppose further that you have a symmetric 2-by-2 matrix, R .

$$R = \begin{bmatrix} 0.65 & 0.61 \\ 0.61 & -3.42 \end{bmatrix};$$

Compute the spectral factorization of the system given by $H = F' * R * F$, without explicitly computing H .

$$[G, S] = \text{spectralfact}(F, R);$$

G is a minimum-phase system with identity feedthrough.

G.D

```
ans = 2x2
```

```
    1    0
    0    1
```

Because F has two inputs and two outputs, both R and S are 2-by-2 matrices.

Confirm that $G' * S * G = F' * R * F$ by comparing the original factorization to the difference between the two factorizations. The singular values of the difference are far below those of the original system.

```
Ff = F'*R*F;
Gf = G'*S*G;
sigmaplot(Ff,Ff-Gf)
```

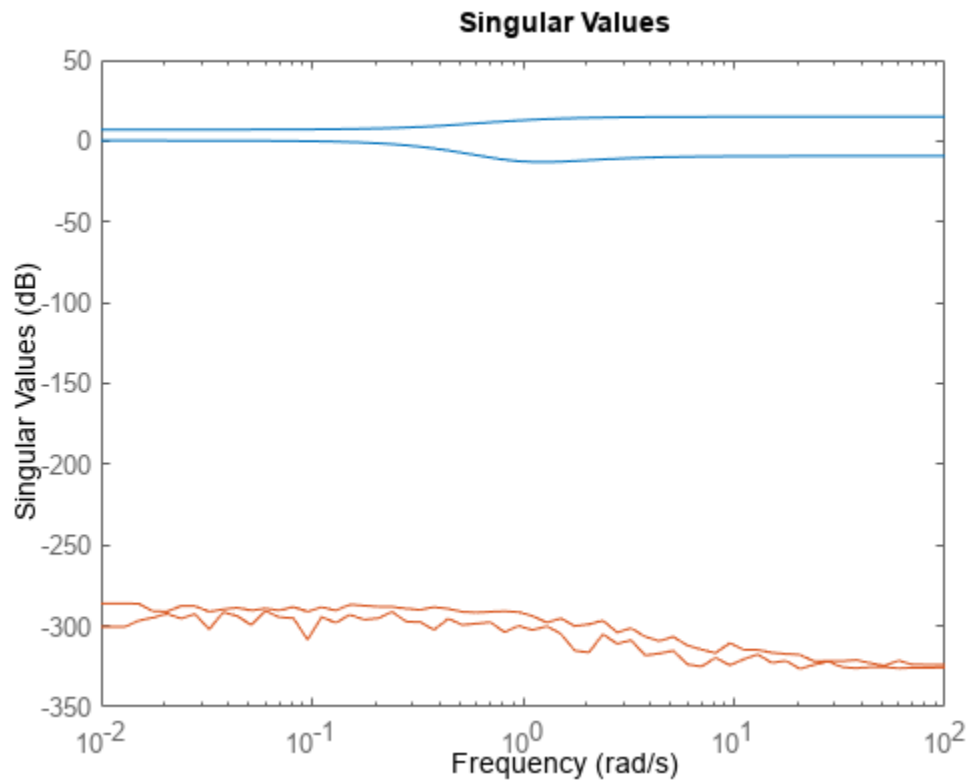

Implicit Factorization

Consider the following discrete-time system.

```
F = zpk(-1.76, [-1+i -1-i], -4, 0.002);
```

F has poles and zeros outside the unit circle. Use `spectralfact` to compute a system G with stable poles and zeros, such that $G' * G = F' * F$.

```
G = spectralfact(F, [])
```

```
G =
```

$$\frac{-3.52 z (z+0.5682)}{(z^2 + z + 0.5)}$$

```
Sample time: 0.002 seconds
Discrete-time zero/pole/gain model.
```

Unlike F, G has no poles or zeroes outside the unit circle. G does have an additional zero at $z = 0$, which is a reflection of the unstable zero at $z = \text{Inf}$ in F.

```
pzplot(G)
```

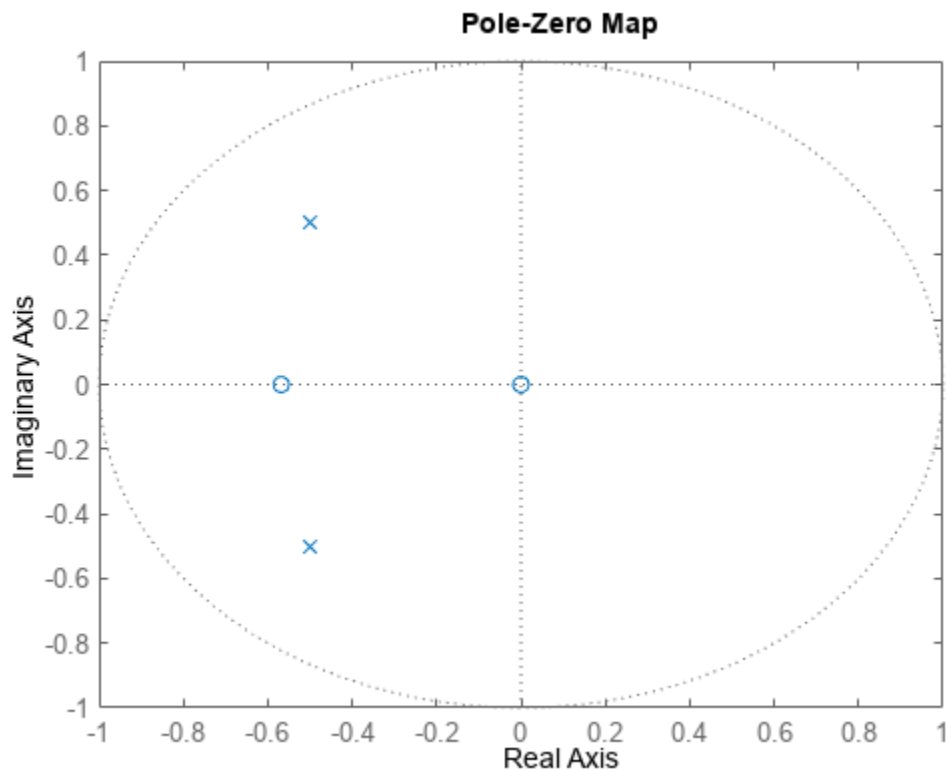

Confirm that $G' * G = F' * F$ by comparing the original factorization to the difference between the two factorizations. The singular values of the difference are far below those of the original factorization.

```
Ff = F'*F;
Gf = G'*G;
sigmaplot(Ff, Ff-Gf)
```

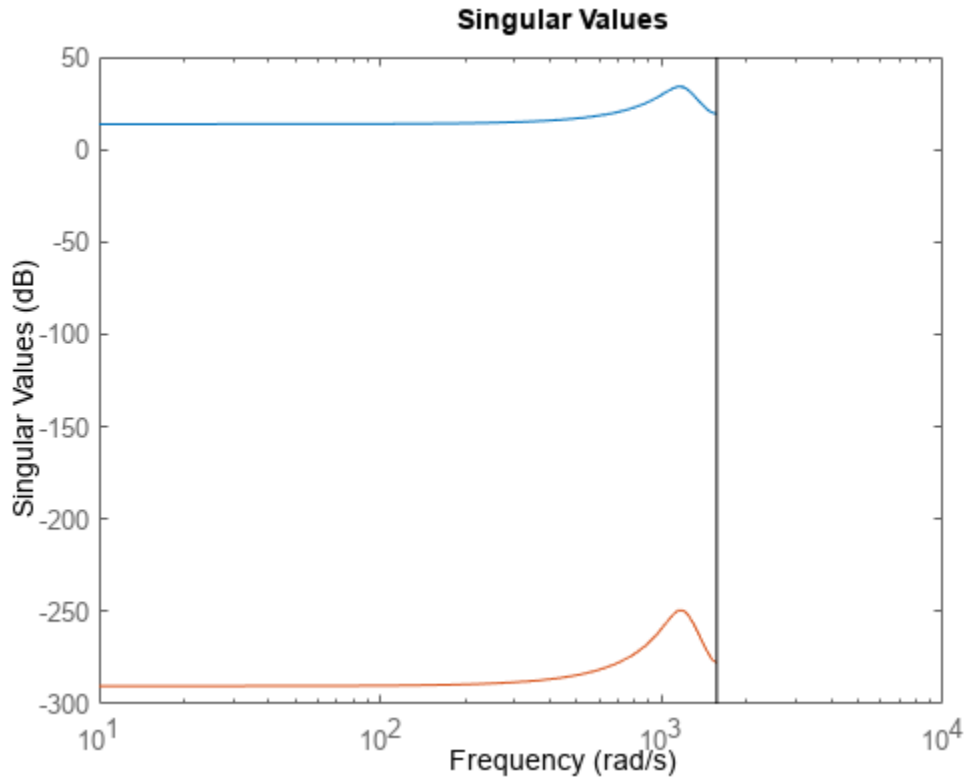

Input Arguments

H — Self-conjugate LTI model

tf | zpk | ss

Self-conjugate LTI model, specified as a `tf`, `ss`, or `zpk` model. Self-conjugate means that is equal to its conjugate, $H = H'$. The conjugate H' is the transfer function $H(-s)^T$ in continuous time and $H(1/z)^T$ in discrete time.

H can be SISO or MIMO, provided it has as many outputs as inputs. H can be continuous or discrete with the following restrictions:

- In continuous time, H must be biproper with no poles or zeros at infinity or on the imaginary axis.
- In discrete time, H must have no poles or zeros on the unit circle.

F — F factor

tf | zpk | ss

F factor of the factored form $H = F' * R * F$, specified as a `tf`, `ss`, or `zpk` model. F cannot have more inputs than outputs.

R — R factor

square matrix

R factor of the factored form $H = F' * R * F$, specified as a symmetric square matrix with as many rows as there are outputs in F.

Output Arguments

G — LTI factor

tf | zpk | ss

LTI factor, returned as a tf, ss, or zpk model. G is a stable, minimum-phase system that satisfies:

- $H = G' * S * G$, if you use the syntax `[G,S] = spectralfact(H)`.
- $G' * S * G = F' * R * F$, if you use the syntax `[G,S] = spectralfact(F,R)`.
- $G' * G = F' * F$, if you use the syntax `G = spectralfact(F,[])`.

S — Numeric factor

matrix

Numeric factor, returned as a symmetric matrix that satisfies:

- $H = G' * S * G$, if you use the syntax `[G,S] = spectralfact(H)`. The dimensions of S match the I/O dimensions of H and G.
- $G' * S * G = F' * R * F$, if you use the syntax `[G,S] = spectralfact(F,R)`. The size of S along each dimension matches the number of outputs of F.

Tips

- `spectralfact` assumes that H is self-conjugate. In some cases when H is not self-conjugate, `spectralfact` returns G and S that do not satisfy $H = G' * S * G$. Therefore, verify that your input model is in fact self-conjugate before using `spectralfact`. One way to verify H is to compare H to $H - H'$ on a singular value plot.

```
sigmaplot(H,H-H')
```

If H is self-conjugate, the $H - H'$ line on the plot lies far below the H line.

Version History

Introduced in R2016a

See Also

stabsep | modsep

Topics

“Arithmetic Operations”

spy

Visualize sparsity pattern of a sparse model

Syntax

```
spy(sys)
spy(AX, sys)
```

Description

`spy(sys)` plots the sparsity pattern of the sparse model `sys`, which can be a first-order (`sparss`) or second-order (`mechss`) model. The plot displays the number of nonzero elements in each sparse matrix of `sys`. To display a matrix, right click the plot and select the desired matrix.

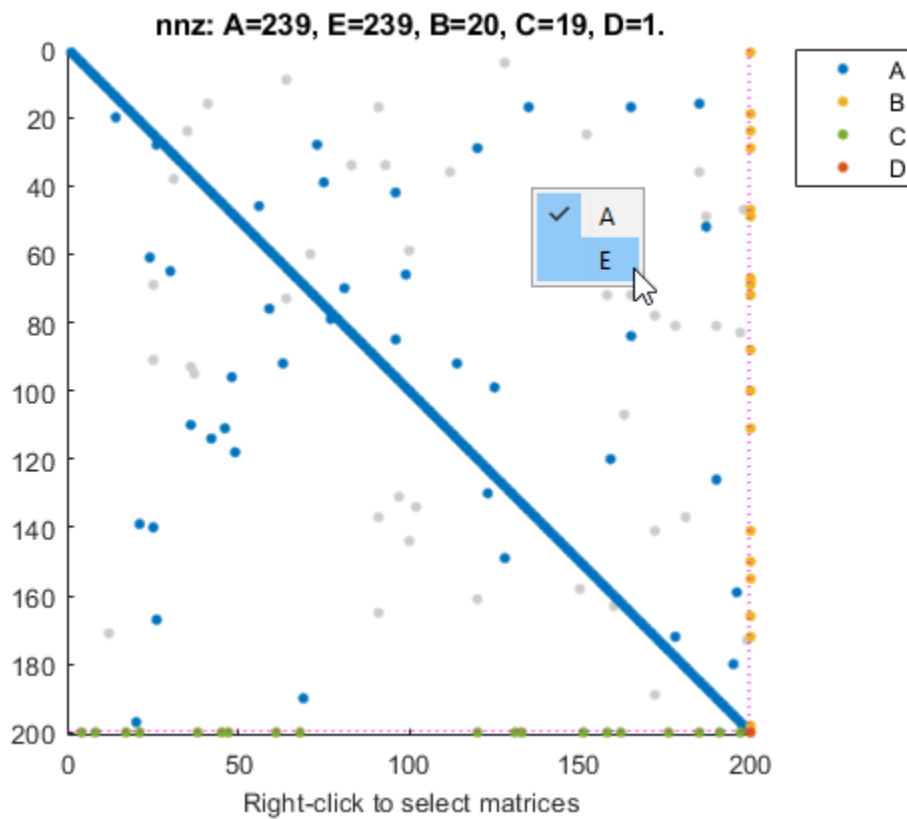

`spy(AX, sys)` plots the sparsity pattern on the `Axes` or `UIAxes` object in the current figure with the handle `AX`. Use this syntax when creating apps with `spy` in the App Designer.

Examples

Continuous-Time Sparse First-Order Model

For this example, consider `sparseFOContinuous.mat` which contains sparse matrices for a continuous-time sparse first-order state-space model.

Extract the sparse matrices from `sparseFOContinuous.mat`.

```
load('sparseFOContinuous.mat','A','B','C','D','E');
```

Create the `sparss` model object.

```
sys = sparss(A,B,C,D,E)
```

Sparse continuous-time state-space model with 1 outputs, 1 inputs, and 199 states.

Use `"spy"` and `"showStateInfo"` to inspect model structure.

Type `"properties('sparss')"` for a list of model properties.

Type `"help sparssOptions"` for available solver options for this model.

The output `sys` is a continuous-time `sparss` model object containing with 199 states, 1 input and 1 output.

You can use the `spy` command to visualize the sparsity of the `sparss` model object.

```
spy(sys)
```

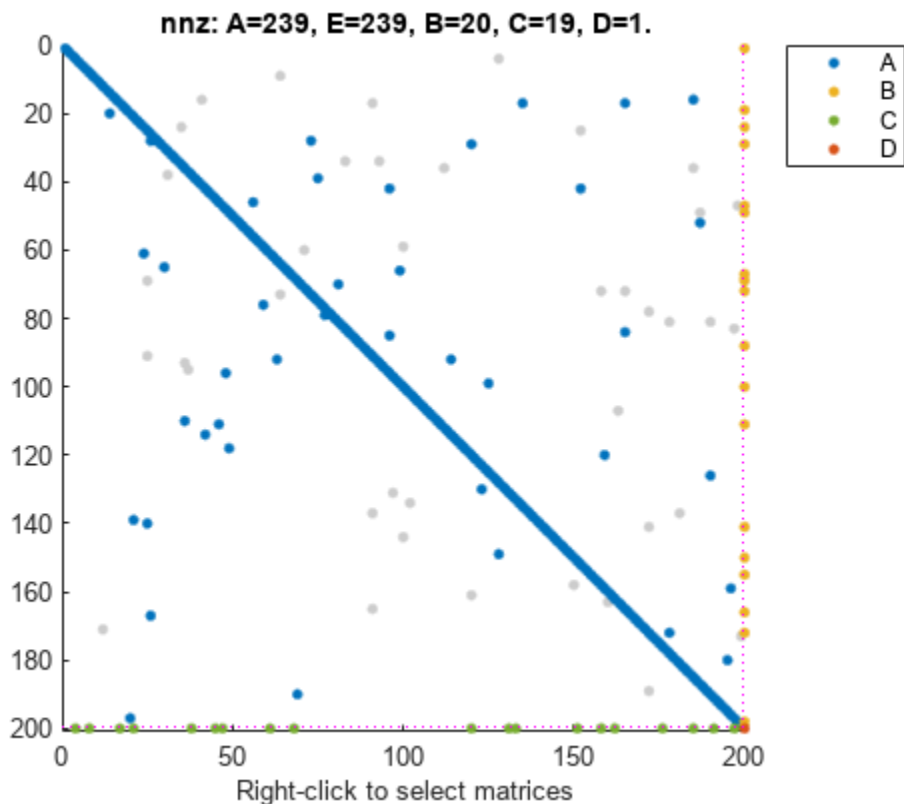

Discrete-Time Sparse First-Order Model

For this example, consider `sparseFODiscrete.mat` which contains sparse matrices for a discrete-time sparse first-order state-space model.

Extract the sparse matrices from `sparseFODiscrete.mat`.

```
load('sparseFODiscrete.mat','A','B','C','D','E','ts');
```

Create the `sparss` model object.

```
sys = sparss(A,B,C,D,E,ts)
```

Sparse discrete-time state-space model with 1 outputs, 1 inputs, and 398 states.

Use `"spy"` and `"showStateInfo"` to inspect model structure.

Type `"properties('sparss')"` for a list of model properties.

Type `"help sparssOptions"` for available solver options for this model.

The output `sys` is a discrete-time `sparss` model object containing with 398 states, 1 input and 1 output.

You can use the `spy` command to visualize the sparsity of the `sparss` model object.

```
spy(sys)
```

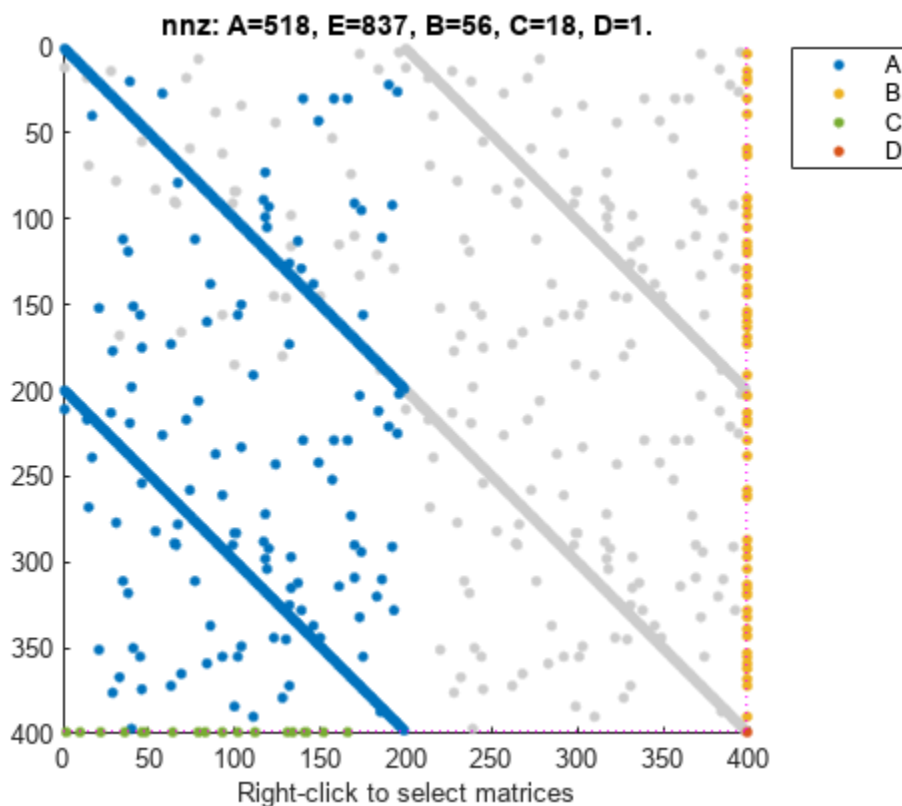

You can also view model properties of the `sparss` model object.

```
properties('sparss')
```

Properties for class sparss:

```
A
B
C
D
E
Scaled
StateInfo
SolverOptions
InternalDelay
InputDelay
OutputDelay
InputName
InputUnit
InputGroup
OutputName
OutputUnit
OutputGroup
Notes
UserData
Name
Ts
TimeUnit
SamplingGrid
```

Continuous-Time Sparse Second-Order Model

For this example, consider the sparse matrices for the 3-D beam model subjected to an impulsive point load at its tip in the file `sparseBeam.mat`.

Extract the sparse matrices from `sparseBeam.mat`.

```
load('sparseBeam.mat','M','K','B','F','G','D');
```

Create the `mechss` model object by specifying `[]` for matrix `C`, since there is no damping.

```
sys = mechss(M,[],K,B,F,G,D)
```

Sparse continuous-time second-order model with 3 outputs, 1 inputs, and 3408 degrees of freedom.

Use `"spy"` and `"showStateInfo"` to inspect model structure.

Type `"properties('mechss')"` for a list of model properties.

Type `"help mechssOptions"` for available solver options for this model.

The output `sys` is a `mechss` model object containing a 3-by-1 array of sparse models with 3408 degrees of freedom, 1 input, and 3 outputs.

You can use the `spy` command to visualize the sparsity of the `mechss` model object.

```
spy(sys)
```

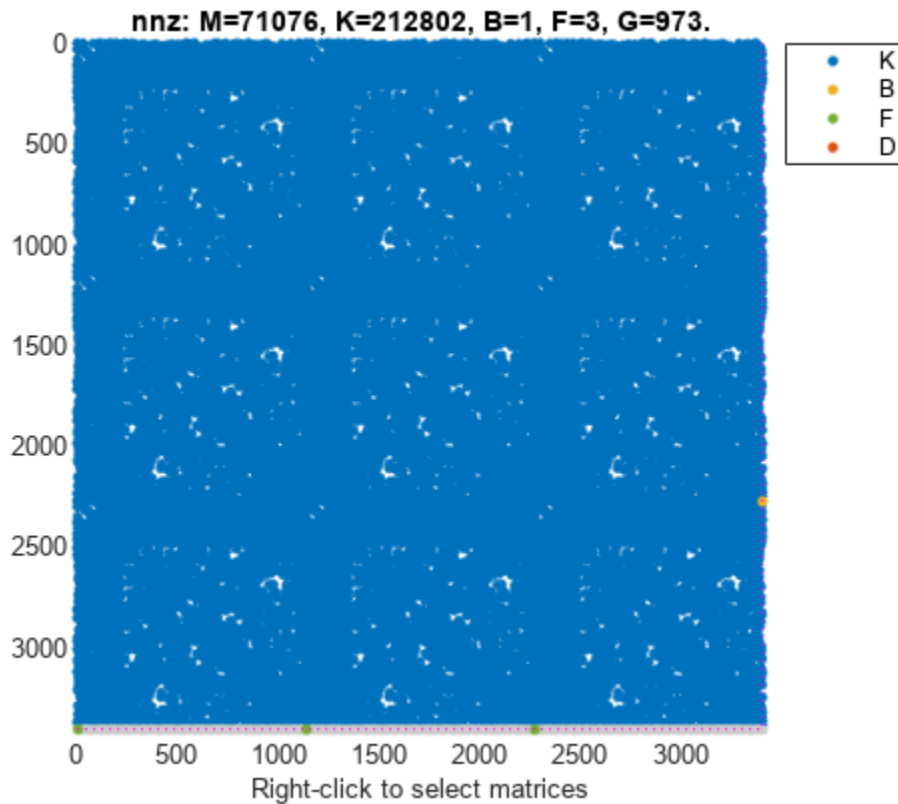

Discrete-Time Sparse Second-Order Model

For this example, consider the sparse matrices of the discrete system in the file `discreteS0Sparse.mat`.

Load the sparse matrices from `discreteS0Sparse.mat`.

```
load('discreteS0Sparse.mat', 'M', 'C', 'K', 'B', 'F', 'G', 'D', 'ts');
```

Create the discrete-time `mechss` model object by specifying the sample time `ts`.

```
sys = mechss(M,C,K,B,F,G,D,ts)
```

Sparse discrete-time second-order model with 1 outputs, 1 inputs, and 28408 degrees of freedom.

Use `"spy"` and `"showStateInfo"` to inspect model structure.

Type `"properties('mechss')"` for a list of model properties.

Type `"help mechssOptions"` for available solver options for this model.

The output `sys` is a discrete-time `mechss` model object with 28408 degrees of freedom, 1 input, and 1 output.

You can use the `spy` command to visualize the sparsity pattern of the `mechss` model object. You can right-click on the plot to select matrices to be displayed.

```
spy(sys)
```

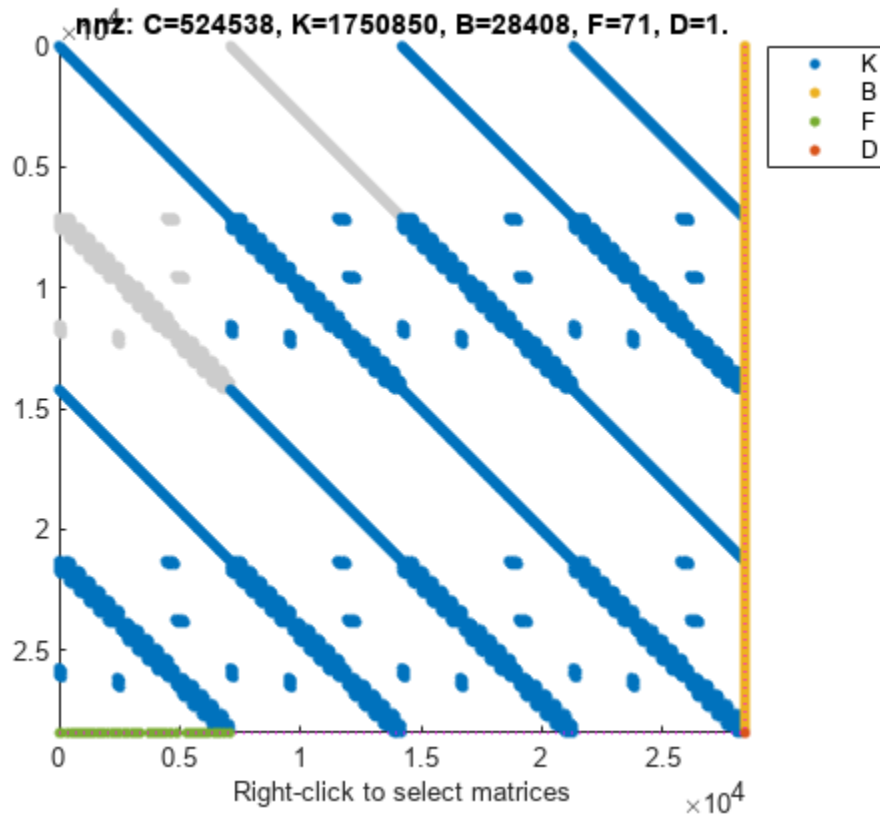

Input Arguments

sys — Sparse model

sparss object | mechss object

Sparse model, specified as a one of the following objects.

- `sparss` — First-order sparse model
- `mechss` — Second-order sparse model

When `sys` contains interfaced or interconnected components, use `spy(xsort(sys))` to view the underlying block arrow structure. For more information about the block arrow structure, see `xsort`.

AX — Object handle

Axes object | UIAxes object

Object handle, specified as an `Axes` or `UIAxes` object. Use `AX` to create apps with `spy` in the App Designer.

Version History

Introduced in R2020b

See Also

sparsr | mechss | xsort | showStateInfo

Topics

“Sparse Model Basics”

SS

State-space model

Description

Use `ss` to create real-valued or complex-valued state-space models, or to convert dynamic system models to state-space model form. You can also use `ss` to create generalized state-space (`genss`) models or uncertain state-space (`uss`) models.

A state-space model is a mathematical representation of a physical system as a set of input, output, and state variables related by first-order differential equations. The state variables define the values of the output variables. The `ss` model object can represent SISO or MIMO state-space models in continuous time or discrete time.

In continuous-time, a state-space model is of the following form:

$$\begin{aligned}\dot{x} &= Ax + Bu \\ y &= Cx + Du\end{aligned}$$

Here, x , u and y represent the states, inputs and outputs respectively, while A , B , C and D are the state-space matrices. The `ss` object represents a state-space model in MATLAB storing A , B , C and D along with other information such as sample time, names and delays specific to the inputs and outputs.

You can create a state-space model object by either specifying the state, input and output matrices directly, or by converting a model of another type (such as a transfer function model `tf`) to state-space form. For more information, see “State-Space Models”. You can use an `ss` model object to:

- Perform linear analysis
- Represent a linear time-invariant (LTI) model to perform control design
- Combine with other LTI models to represent a more complex system

Creation

Syntax

```
sys = ss(A,B,C,D)
sys = ss(A,B,C,D,ts)
sys = ss(A,B,C,D,ltiSys)
sys = ss(D)
sys = ss( ___,Name,Value)

sys = ss(ltiSys)
sys = ss(ltiSys,component)

sys = ss(ssSys,'minimal')
sys = ss(ssSys,'explicit')
```

Description

`sys = ss(A,B,C,D)` creates a continuous-time state-space model object of the following form:

$$\begin{aligned}\dot{x} &= Ax + Bu \\ y &= Cx + Du\end{aligned}$$

For instance, consider a plant with N_x states, N_y outputs, and N_u inputs. The state-space matrices are:

- A is an N_x -by- N_x real- or complex-valued matrix.
- B is an N_x -by- N_u real- or complex-valued matrix.
- C is an N_y -by- N_x real- or complex-valued matrix.
- D is an N_y -by- N_u real- or complex-valued matrix.

`sys = ss(A,B,C,D,ts)` creates the discrete-time state-space model object of the following form with the sample time `ts` (in seconds):

$$\begin{aligned}x[n+1] &= Ax[n] + Bu[n] \\ y[n] &= Cx[n] + Du[n]\end{aligned}$$

To leave the sample time unspecified, set `ts` to `-1`.

`sys = ss(A,B,C,D,ltiSys)` creates a state-space model with properties such as input and output names, internal delays and sample time values inherited from the model `ltiSys`.

`sys = ss(D)` creates a state-space model that represents the static gain, D . The output state-space model is equivalent to `ss([],[],[],D)`.

`sys = ss(____,Name,Value)` sets properties of the state-space model using one or more `Name,Value` pair arguments for any of the previous input-argument combinations.

`sys = ss(ltiSys)` converts the dynamic system model `ltiSys` to a state-space model. If `ltiSys` contains tunable or uncertain elements, `ss` uses the current or nominal values for those elements respectively.

`sys = ss(ltiSys,component)` converts to `ss` object form the measured component, the noise component or both of specified `component` of an identified linear time-invariant (LTI) model `ltiSys`. Use this syntax only when `ltiSys` is an identified (LTI) model such as an `idtf`, `idss`, `idproc`, `idpoly` or `idgrey` object.

`sys = ss(ssSys,'minimal')` returns the minimal state-space realization with no uncontrollable or unobservable states. This realization is equivalent to `minreal(ss(sys))` where matrix A has the smallest possible dimension.

Conversion to state-space form is not uniquely defined in the SISO case. It is also not guaranteed to produce a minimal realization in the MIMO case. For more information, see “Recommended Working Representation”.

`sys = ss(ssSys,'explicit')` returns an explicit state-space realization ($E = I$) of the dynamic system state-space model `ssSys`. `ss` returns an error if `ssSys` is improper. For more information on explicit state-space realization, see “State-Space Models”.

Input Arguments

A — State matrix

N_x -by- N_x matrix

State matrix, specified as an N_x -by- N_x matrix where, N_x is the number of states. This input sets the value of property A.

B — Input-to-state matrix

N_x -by- N_u matrix

Input-to-state matrix, specified as an N_x -by- N_u matrix where, N_x is the number of states and N_u is the number of inputs. This input sets the value of property B.

C — State-to-output matrix

N_y -by- N_x matrix

State-to-output matrix, specified as an N_y -by- N_x matrix where, N_x is the number of states and N_y is the number of outputs. This input sets the value of property C.

D — Feedthrough matrix

N_y -by- N_u matrix

Feedthrough matrix, specified as an N_y -by- N_u matrix where, N_y is the number of outputs and N_u is the number of inputs. This input sets the value of property D.

ts — Sample time

scalar

Sample time, specified as a scalar. For more information, see Ts property.

ltiSys — Dynamic system to convert to state-space form

dynamic system model | model array

Dynamic system to convert to state-space form, specified as a SISO or MIMO dynamic system model or array of dynamic system models. Dynamic systems that you can convert include:

- Continuous-time or discrete-time numeric LTI models, such as `tf`, `zpk`, `ss`, or `pid` models.
- Generalized or uncertain LTI models such as `genss` or `uss` models. (Using uncertain models requires Robust Control Toolbox software.)

The resulting state-space model assumes

- current values of the tunable components for tunable control design blocks.
- nominal model values for uncertain control design blocks.
- Identified LTI models, such as `idtf`, `idss`, `idproc`, `idpoly`, and `idgrey` models. To select the component of the identified model to convert, specify `component`. If you do not specify `component`, `ss` converts the measured component of the identified model by default. (Using identified models requires System Identification Toolbox software.)

component — Component of identified model

'measured' (default) | 'noise' | 'augmented'

Component of identified model to convert, specified as one of the following:

- 'measured' — Convert the measured component of `sys`.
- 'noise' — Convert the noise component of `sys`
- 'augmented' — Convert both the measured and noise components of `sys`.

`component` only applies when `sys` is an identified LTI model.

For more information on identified LTI models and their measured and noise components, see “Identified LTI Models”.

ssSys — Dynamic system model to convert to minimal realization or explicit form

`ss` model object

Dynamic system model to convert to minimal realization or explicit form, specified as an `ss` model object.

Output Arguments

sys — Output system model

`ss` model object | `genss` model object | `uss` model object

Output system model, returned as:

- A state-space (`ss`) model object, when the inputs `A`, `B`, `C` and `D` are numeric matrices or when converting from another model object type.
- A generalized state-space model (`genss`) object, when one or more of the matrices `A`, `B`, `C` and `D` includes tunable parameters, such as `realp` parameters or generalized matrices (`genmat`). For an example, see “Create State-Space Model with Both Fixed and Tunable Parameters” on page 2-1262.
- An uncertain state-space model (`uss`) object, when one or more of the inputs `A`, `B`, `C` and `D` includes uncertain matrices. Using uncertain models requires Robust Control Toolbox software.

Properties

A — State matrix

`Nx-by-Nx` matrix

State matrix, specified as an `Nx-by-Nx` matrix where `Nx` is the number of states. The state-matrix can be represented in many ways depending on the desired state-space model realization such as:

- Model Canonical Form
- Companion Canonical Form
- Observable Canonical Form
- Controllable Canonical Form

For more information, see “State-Space Realizations”.

B — Input-to-state matrix

`Nx-by-Nu` matrix

Input-to-state matrix, specified as an `Nx-by-Nu` matrix where `Nx` is the number of states and `Nu` is the number of inputs.

C — State-to-output matrix

Ny-by-Nx matrix

State-to-output matrix, specified as an Ny-by-Nx matrix where Nx is the number of states and Ny is the number of outputs.

D — Feedthrough matrix

Ny-by-Nu matrix

Feedthrough matrix, specified as an Ny-by-Nu matrix where Ny is the number of outputs and Nu is the number of inputs. D is also called as the static gain matrix which represents the ratio of the output to the input under steady state condition.

E — Matrix for implicit state-space models

[] (default) | Nx-by-Nx matrix

Matrix for implicit or descriptor state-space models, specified as a Nx-by-Nx matrix. E is empty by default, meaning that the state equation is explicit. To specify an implicit state equation $E \frac{dx}{dt} = Ax + Bu$, set this property to a square matrix of the same size as A. See `dss` for more information about creating descriptor state-space models.

Scaled — Logical value indicating whether scaling is enabled or disabled

0 (default) | 1

Logical value indicating whether scaling is enabled or disabled, specified as either 0 or 1.

When Scaled is set to 0 (disabled), then most numerical algorithms acting on the state-space model `sys` automatically rescale the state vector to improve numerical accuracy. You can prevent such auto-scaling by setting Scaled to 1 (enabled).

For more information about scaling, see `prescale`.

StateName — State names

' ' (default) | character vector | cell array of character vectors

State names, specified as one of the following:

- Character vector — For first-order models, for example, 'velocity'.
- Cell array of character vectors — For models with two or more states

StateName is empty ' ' for all states by default.

StatePath — State path

' ' (default) | character vector | cell array of character vectors

State path to facilitate state block path management in linearization, specified as one of the following:

- Character vector — For first-order models
- Cell array of character vectors — For models with two or more states

StatePath is empty ' ' for all states by default.

StateUnit — State units

' ' (default) | character vector | cell array of character vectors

State units, specified as one of the following:

- Character vector — For first-order models, for example, 'm/s'
- Cell array of character vectors — For models with two or more states

Use `StateUnit` to keep track of the units of each state. `StateUnit` has no effect on system behavior. `StateUnit` is empty ' ' for all states by default.

InternalDelay — Internal delays in the model

vector

Internal delays in the model, specified as a vector. Internal delays arise, for example, when closing feedback loops on systems with delays, or when connecting delayed systems in series or parallel. For more information about internal delays, see “Closing Feedback Loops with Time Delays”.

For continuous-time models, internal delays are expressed in the time unit specified by the `TimeUnit` property of the model. For discrete-time models, internal delays are expressed as integer multiples of the sample time `Ts`. For example, `InternalDelay = 3` means a delay of three sampling periods.

You can modify the values of internal delays using the property `InternalDelay`. However, the number of entries in `sys.InternalDelay` cannot change, because it is a structural property of the model.

InputDelay — Input delay

0 (default) | scalar | Nu-by-1 vector

Input delay for each input channel, specified as one of the following:

- Scalar — Specify the input delay for a SISO system or the same delay for all inputs of a multi-input system.
- Nu-by-1 vector — Specify separate input delays for input of a multi-input system, where Nu is the number of inputs.

For continuous-time systems, specify input delays in the time unit specified by the `TimeUnit` property. For discrete-time systems, specify input delays in integer multiples of the sample time, `Ts`.

For more information, see “Time Delays in Linear Systems”.

OutputDelay — Output delay

0 (default) | scalar | Ny-by-1 vector

Output delay for each output channel, specified as one of the following:

- Scalar — Specify the output delay for a SISO system or the same delay for all outputs of a multi-output system.
- Ny-by-1 vector — Specify separate output delays for output of a multi-output system, where Ny is the number of outputs.

For continuous-time systems, specify output delays in the time unit specified by the `TimeUnit` property. For discrete-time systems, specify output delays in integer multiples of the sample time, `Ts`.

For more information, see “Time Delays in Linear Systems”.

Ts — Sample time

0 (default) | positive scalar | -1

Sample time, specified as:

- 0 for continuous-time systems.
- A positive scalar representing the sampling period of a discrete-time system. Specify Ts in the time unit specified by the `TimeUnit` property.
- -1 for a discrete-time system with an unspecified sample time.

Note Changing Ts does not discretize or resample the model. To convert between continuous-time and discrete-time representations, use `c2d` and `d2c`. To change the sample time of a discrete-time system, use `d2d`.

TimeUnit — Time variable units

'seconds' (default) | 'nanoseconds' | 'microseconds' | 'milliseconds' | 'minutes' | 'hours' | 'days' | 'weeks' | 'months' | 'years' | ...

Time variable units, specified as one of the following:

- 'nanoseconds'
- 'microseconds'
- 'milliseconds'
- 'seconds'
- 'minutes'
- 'hours'
- 'days'
- 'weeks'
- 'months'
- 'years'

Changing `TimeUnit` has no effect on other properties, but changes the overall system behavior. Use `chgTimeUnit` to convert between time units without modifying system behavior.

InputName — Input channel names

' ' (default) | character vector | cell array of character vectors

Input channel names, specified as one of the following:

- A character vector, for single-input models.
- A cell array of character vectors, for multi-input models.
- ' ', no names specified, for any input channels.

Alternatively, you can assign input names for multi-input models using automatic vector expansion. For example, if `sys` is a two-input model, enter the following:

```
sys.InputName = 'controls';
```

The input names automatically expand to {'controls(1)'; 'controls(2)'}

You can use the shorthand notation `u` to refer to the `InputName` property. For example, `sys.u` is equivalent to `sys.InputName`.

Use `InputName` to:

- Identify channels on model display and plots.
- Extract subsystems of MIMO systems.
- Specify connection points when interconnecting models.

InputUnit — Input channel units

`''` (default) | character vector | cell array of character vectors

Input channel units, specified as one of the following:

- A character vector, for single-input models.
- A cell array of character vectors, for multi-input models.
- `''`, no units specified, for any input channels.

Use `InputUnit` to specify input signal units. `InputUnit` has no effect on system behavior.

InputGroup — Input channel groups

structure

Input channel groups, specified as a structure. Use `InputGroup` to assign the input channels of MIMO systems into groups and refer to each group by name. The field names of `InputGroup` are the group names and the field values are the input channels of each group. For example, enter the following to create input groups named `controls` and `noise` that include input channels 1 and 2, and 3 and 5, respectively.

```
sys.InputGroup.controls = [1 2];  
sys.InputGroup.noise = [3 5];
```

You can then extract the subsystem from the `controls` inputs to all outputs using the following.

```
sys(:, 'controls')
```

By default, `InputGroup` is a structure with no fields.

OutputName — Output channel names

`''` (default) | character vector | cell array of character vectors

Output channel names, specified as one of the following:

- A character vector, for single-output models.
- A cell array of character vectors, for multi-output models.
- `''`, no names specified, for any output channels.

Alternatively, you can assign output names for multi-output models using automatic vector expansion. For example, if `sys` is a two-output model, enter the following.

```
sys.OutputName = 'measurements';
```

The output names automatically expand to `{'measurements(1)'; 'measurements(2)'}`.

You can also use the shorthand notation `y` to refer to the `OutputName` property. For example, `sys.y` is equivalent to `sys.OutputName`.

Use `OutputName` to:

- Identify channels on model display and plots.
- Extract subsystems of MIMO systems.
- Specify connection points when interconnecting models.

OutputUnit — Output channel units

' ' (default) | character vector | cell array of character vectors

Output channel units, specified as one of the following:

- A character vector, for single-output models.
- A cell array of character vectors, for multi-output models.
- ' ', no units specified, for any output channels.

Use `OutputUnit` to specify output signal units. `OutputUnit` has no effect on system behavior.

OutputGroup — Output channel groups

structure

Output channel groups, specified as a structure. Use `OutputGroup` to assign the output channels of MIMO systems into groups and refer to each group by name. The field names of `OutputGroup` are the group names and the field values are the output channels of each group. For example, create output groups named `temperature` and `measurement` that include output channels 1, and 3 and 5, respectively.

```
sys.OutputGroup.temperature = [1];
sys.OutputGroup.measurement = [3 5];
```

You can then extract the subsystem from all inputs to the `measurement` outputs using the following.

```
sys('measurement', :)
```

By default, `OutputGroup` is a structure with no fields.

Name — System name

' ' (default) | character vector

System name, specified as a character vector. For example, `'system_1'`.

Notes — User-specified text

{ } (default) | character vector | cell array of character vectors

User-specified text that you want to associate with the system, specified as a character vector or cell array of character vectors. For example, `'System is MIMO'`.

UserData — User-specified data

[] (default) | any MATLAB data type

User-specified data that you want to associate with the system, specified as any MATLAB data type.

SamplingGrid — Sampling grid for model arrays

structure array

Sampling grid for model arrays, specified as a structure array.

Use `SamplingGrid` to track the variable values associated with each model in a model array, including identified linear time-invariant (IDLTI) model arrays.

Set the field names of the structure to the names of the sampling variables. Set the field values to the sampled variable values associated with each model in the array. All sampling variables must be numeric scalars, and all arrays of sampled values must match the dimensions of the model array.

For example, you can create an 11-by-1 array of linear models, `sysarr`, by taking snapshots of a linear time-varying system at times `t = 0:10`. The following code stores the time samples with the linear models.

```
sysarr.SamplingGrid = struct('time',0:10)
```

Similarly, you can create a 6-by-9 model array, `M`, by independently sampling two variables, `zeta` and `w`. The following code maps the (`zeta,w`) values to `M`.

```
[zeta,w] = ndgrid(<6 values of zeta>,<9 values of w>)
M.SamplingGrid = struct('zeta',zeta,'w',w)
```

When you display `M`, each entry in the array includes the corresponding `zeta` and `w` values.

`M`

```
M(:,:,1,1) [zeta=0.3, w=5] =
```

```
      25
-----
s^2 + 3 s + 25
```

```
M(:,:,2,1) [zeta=0.35, w=5] =
```

```
      25
-----
s^2 + 3.5 s + 25
```

...

For model arrays generated by linearizing a Simulink model at multiple parameter values or operating points, the software populates `SamplingGrid` automatically with the variable values that correspond to each entry in the array. For instance, the Simulink Control Design commands `linearize` and `sLinearizer` populate `SamplingGrid` automatically.

By default, `SamplingGrid` is a structure with no fields.

Object Functions

The following lists contain a representative subset of the functions you can use with `ss` model objects. In general, any function applicable to “Dynamic System Models” is applicable to an `ss` object.

Linear Analysis

<code>step</code>	Step response plot of dynamic system; step response data
<code>impulse</code>	Impulse response plot of dynamic system; impulse response data

lsim	Plot simulated time response of dynamic system to arbitrary inputs; simulated response data
bode	Bode plot of frequency response, or magnitude and phase data
nyquist	Nyquist plot of frequency response
nichols	Nichols chart of frequency response
bandwidth	Frequency response bandwidth

Stability Analysis

pole	Poles of dynamic system
zero	Zeros and gain of SISO dynamic system
pzplot	Pole-zero plot of dynamic system model with additional plot customization options
margin	Gain margin, phase margin, and crossover frequencies

Model Transformation

zpk	Zero-pole-gain model
tf	Transfer function model
c2d	Convert model from continuous to discrete time
d2c	Convert model from discrete to continuous time
d2d	Resample discrete-time model

Model Interconnection

feedback	Feedback connection of multiple models
connect	Block diagram interconnections of dynamic systems
series	Series connection of two models
parallel	Parallel connection of two models

Controller Design

pidtune	PID tuning algorithm for linear plant model
rlocus	Root locus plot of dynamic system
lqr	Linear-Quadratic Regulator (LQR) design
lqg	Linear-Quadratic-Gaussian (LQG) design
lqi	Linear-Quadratic-Integral control
kalman	Design Kalman filter for state estimation

Examples

SISO State-Space Model

Create the SISO state-space model defined by the following state-space matrices:

$$A = \begin{bmatrix} -1.5 & -2 \\ 1 & 0 \end{bmatrix} \quad B = \begin{bmatrix} 0.5 \\ 0 \end{bmatrix} \quad C = [0 \ 1] \quad D = 0$$

Specify the A, B, C and D matrices, and create the state-space model.

```
A = [-1.5, -2; 1, 0];
B = [0.5; 0];
C = [0, 1];
D = 0;
sys = ss(A, B, C, D)
```

```
sys =  
  
A =  
    x1    x2  
x1 -1.5  -2  
x2  1     0  
  
B =  
    u1  
x1  0.5  
x2  0  
  
C =  
    x1  x2  
y1  0   1  
  
D =  
    u1  
y1  0
```

Continuous-time state-space model.

Create Discrete-Time State-Space Model

Create a state-space model with a sample time of 0.25 seconds and the following state-space matrices:

$$A = \begin{bmatrix} 0 & 1 \\ -5 & -2 \end{bmatrix} \quad B = \begin{bmatrix} 0 \\ 3 \end{bmatrix} \quad C = [0 \ 1] \quad D = [0]$$

Specify the state-space matrices.

```
A = [0 1; -5 -2];  
B = [0; 3];  
C = [0 1];  
D = 0;
```

Specify the sample time.

```
Ts = 0.25;
```

Create the state-space model.

```
sys = ss(A,B,C,D,Ts);
```

Continuous-Time MIMO State-Space Model

For this example, consider a cube rotating about its corner with inertia tensor J and a damping force F of 0.2 magnitude. The input to the system is the driving torque while the angular velocities are the outputs. The state-space matrices for the cube are:

$$A = -J^{-1}F, \quad B = J^{-1}, \quad C = I, \quad D = 0,$$

$$\text{where, } J = \begin{bmatrix} 8 & -3 & -3 \\ -3 & 8 & -3 \\ -3 & -3 & 8 \end{bmatrix} \text{ and } F = \begin{bmatrix} 0.2 & 0 & 0 \\ 0 & 0.2 & 0 \\ 0 & 0 & 0.2 \end{bmatrix}$$

Specify the A, B, C and D matrices, and create the continuous-time state-space model.

```
J = [8 -3 -3; -3 8 -3; -3 -3 8];
F = 0.2*eye(3);
A = -J\F;
B = inv(J);
C = eye(3);
D = 0;
sys = ss(A,B,C,D)
```

sys =

```
A =
      x1      x2      x3
x1 -0.04545 -0.02727 -0.02727
x2 -0.02727 -0.04545 -0.02727
x3 -0.02727 -0.02727 -0.04545
```

```
B =
      u1      u2      u3
x1 0.2273 0.1364 0.1364
x2 0.1364 0.2273 0.1364
x3 0.1364 0.1364 0.2273
```

```
C =
      x1  x2  x3
y1  1   0   0
y2  0   1   0
y3  0   0   1
```

```
D =
      u1  u2  u3
y1  0   0   0
y2  0   0   0
y3  0   0   0
```

Continuous-time state-space model.

sys is MIMO since the system contains 3 inputs and 3 outputs observed from matrices C and D. For more information on MIMO state-space models, see “MIMO State-Space Models”.

Discrete-Time MIMO State-Space Model

Create a state-space model using the following discrete-time, multi-input, multi-output state matrices with sample time $t_s = 0.2$ seconds:

$$A = \begin{bmatrix} -7 & 0 \\ 0 & -10 \end{bmatrix} \quad B = \begin{bmatrix} 5 & 0 \\ 0 & 2 \end{bmatrix} \quad C = \begin{bmatrix} 1 & -4 \\ -4 & 0.5 \end{bmatrix} \quad D = \begin{bmatrix} 0 & -2 \\ 2 & 0 \end{bmatrix}$$

Specify the state-space matrices and create the discrete-time MIMO state-space model.

```
A = [-7,0;0,-10];  
B = [5,0;0,2];  
C = [1,-4;-4,0.5];  
D = [0,-2;2,0];  
ts = 0.2;  
sys = ss(A,B,C,D,ts)
```

```
sys =
```

```
A =  
      x1    x2  
x1   -7     0  
x2     0  -10
```

```
B =  
      u1    u2  
x1     5     0  
x2     0     2
```

```
C =  
      x1    x2  
y1     1   -4  
y2    -4   0.5
```

```
D =  
      u1    u2  
y1     0   -2  
y2     2     0
```

```
Sample time: 0.2 seconds  
Discrete-time state-space model.
```

Specify State and Input Names for State-Space Model

Create state-space matrices and specify sample time.

```
A = [0 1;-5 -2];  
B = [0;3];  
C = [0 1];  
D = 0;  
Ts = 0.05;
```

Create the state-space model, specifying the state and input names using name-value pairs.

```
sys = ss(A,B,C,D,Ts,'StateName',{'Position' 'Velocity'},...  
        'InputName','Force');
```

The number of state and input names must be consistent with the dimensions of A, B, C, and D.

Naming the inputs and outputs can be useful when dealing with response plots for MIMO systems.

```
step(sys)
```

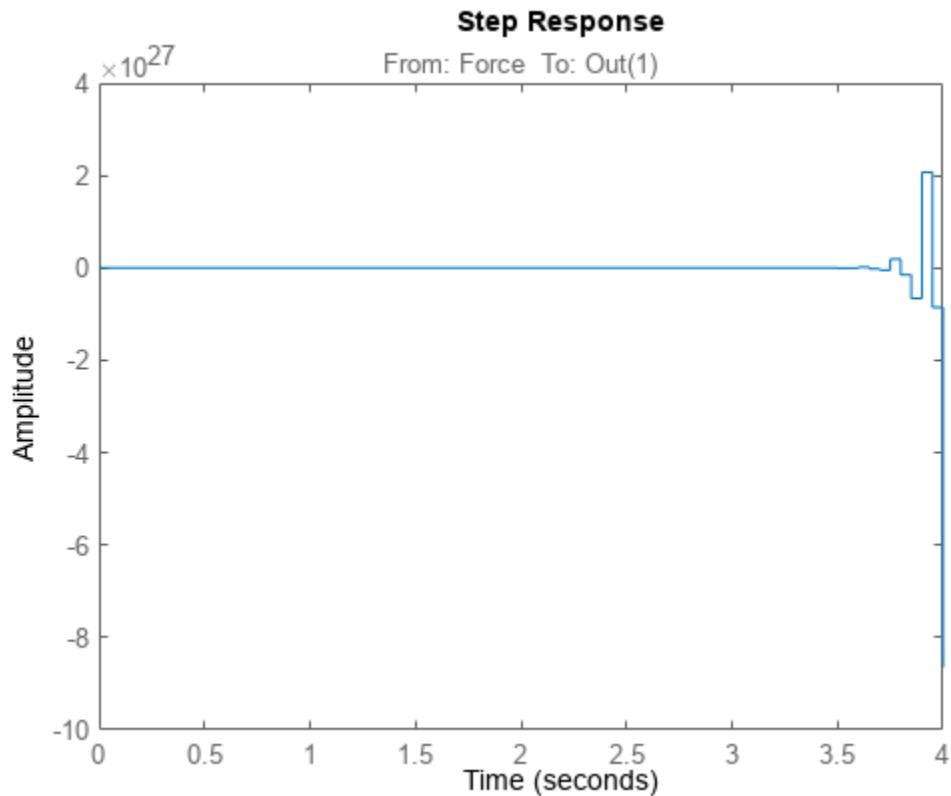

Notice the input name Force in the title of the step response plot.

State-Space Model with Inherited Properties

For this example, create a state-space model with the same time and input unit properties inherited from another state-space model. Consider the following state-space models:

$$A_1 = \begin{bmatrix} -1.5 & -2 \\ 1 & 0 \end{bmatrix} \quad B_1 = \begin{bmatrix} 0.5 \\ 0 \end{bmatrix} \quad C_1 = [0 \ 1] \quad D_1 = 5$$

$$A_2 = \begin{bmatrix} 7 & -1 \\ 0 & 2 \end{bmatrix} \quad B_2 = \begin{bmatrix} 0.85 \\ 2 \end{bmatrix} \quad C_2 = [10 \ 14] \quad D_2 = 2$$

First, create a state-space model `sys1` with the `TimeUnit` and `InputUnit` property set to 'minutes'.

```
A1 = [-1.5, -2; 1, 0];
B1 = [0.5; 0];
C1 = [0, 1];
D1 = 5;
sys1 = ss(A1, B1, C1, D1, 'TimeUnit', 'minutes', 'InputUnit', 'minutes');
```

Verify that the time and input unit properties of `sys1` are set to 'minutes'.

```
propValues1 = [sys1.TimeUnit, sys1.InputUnit]
```

```
propValues1 = 1x2 cell
    {'minutes'}    {'minutes'}
```

Create the second state-space model with properties inherited from `sys1`.

```
A2 = [7, -1; 0, 2];
B2 = [0.85; 2];
C2 = [10, 14];
D2 = 2;
sys2 = ss(A2, B2, C2, D2, sys1);
```

Verify that the time and input units of `sys2` have been inherited from `sys1`.

```
propValues2 = [sys2.TimeUnit, sys2.InputUnit]

propValues2 = 1x2 cell
    {'minutes'}    {'minutes'}
```

MIMO Static Gain State-Space Model

In this example, you will create a static gain MIMO state-space model.

Consider the following two-input, two-output static gain matrix:

$$D = \begin{bmatrix} 2 & 4 \\ 3 & 5 \end{bmatrix}$$

Specify the gain matrix and create the static gain state-space model.

```
D = [2, 4; 3, 5];
sys1 = ss(D)
```

```
sys1 =
```

```
D =
      u1  u2
y1      2   4
y2      3   5
```

Static gain.

Convert Transfer Function to State-Space Model

Compute the state-space model of the following transfer function:

$$H(s) = \begin{bmatrix} \frac{s + 1}{s^3 + 3s^2 + 3s + 2} \\ \frac{s^2 + 3}{s^2 + s + 1} \end{bmatrix}$$

Create the transfer function model.

```
H = [tf([1 1],[1 3 3 2]) ; tf([1 0 3],[1 1 1])];
```

Convert this model to a state-space model.

```
sys = ss(H);
```

Examine the size of the state-space model.

```
size(sys)
```

State-space model with 2 outputs, 1 inputs, and 5 states.

The number of states is equal to the cumulative order of the SISO entries in $H(s)$.

To obtain a minimal realization of $H(s)$, enter

```
sys = ss(H, 'minimal');
size(sys)
```

State-space model with 2 outputs, 1 inputs, and 3 states.

The resulting model has an order of three, which is the minimum number of states needed to represent $H(s)$. To see this number of states, refactor $H(s)$ as the product of a first-order system and a second-order system.

$$H(s) = \begin{bmatrix} \frac{1}{s+2} & 0 \\ 0 & 1 \end{bmatrix} \begin{bmatrix} \frac{s+1}{s^2+s+1} \\ \frac{s^2+3}{s^2+s+1} \end{bmatrix}$$

Extract State-Space Models from Identified Model

For this example, extract the measured and noise components of an identified polynomial model into two separate state-space models.

Load the Box-Jenkins polynomial model `ltiSys` in `identifiedModel.mat`.

```
load('identifiedModel.mat','ltiSys');
```

`ltiSys` is an identified discrete-time model of the form: $y(t) = \frac{B}{F}u(t) + \frac{C}{D}e(t)$, where $\frac{B}{F}$ represents the measured component and $\frac{C}{D}$ the noise component.

Extract the measured and noise components as state-space models.

```
sysMeas = ss(ltiSys, 'measured')
```

```
sysMeas =
```

```
A =
      x1      x2
```

```
x1  1.575  -0.6115
x2      1      0
```

```
B =
      u1
x1  0.5
x2   0
```

```
C =
      x1      x2
y1 -0.2851  0.3916
```

```
D =
      u1
y1   0
```

Input delays (sampling periods): 2

Sample time: 0.04 seconds
Discrete-time state-space model.

```
sysNoise = ss(ltiSys, 'noise')
```

```
sysNoise =
```

```
A =
      x1      x2      x3
x1  1.026  -0.26  0.3899
x2      1      0      0
x3      0      0.5  0
```

```
B =
      v@y1
x1  0.25
x2   0
x3   0
```

```
C =
      x1      x2      x3
y1  0.319 -0.04738  0.07106
```

```
D =
      v@y1
y1  0.04556
```

Input groups:

Name	Channels
Noise	1

Sample time: 0.04 seconds
Discrete-time state-space model.

The measured component can serve as a plant model, while the noise component can be used as a disturbance model for control system design.

Explicit Realization of Descriptor State-Space Model

Create a descriptor state-space model ($E \neq I$).

```
a = [2 -4; 4 2];
b = [-1; 0.5];
c = [-0.5, -2];
d = [-1];
e = [1 0; -3 0.5];
sysd = dss(a,b,c,d,e);
```

Compute an explicit realization of the system ($E = I$).

```
syse = ss(sysd, 'explicit')
```

```
syse =
```

```
A =
      x1    x2
x1      2   -4
x2     20  -20
```

```
B =
      u1
x1   -1
x2   -5
```

```
C =
      x1    x2
y1  -0.5   -2
```

```
D =
      u1
y1   -1
```

Continuous-time state-space model.

Confirm that the descriptor and explicit realizations have equivalent dynamics.

```
bodeplot(sysd,syse, 'g--')
```

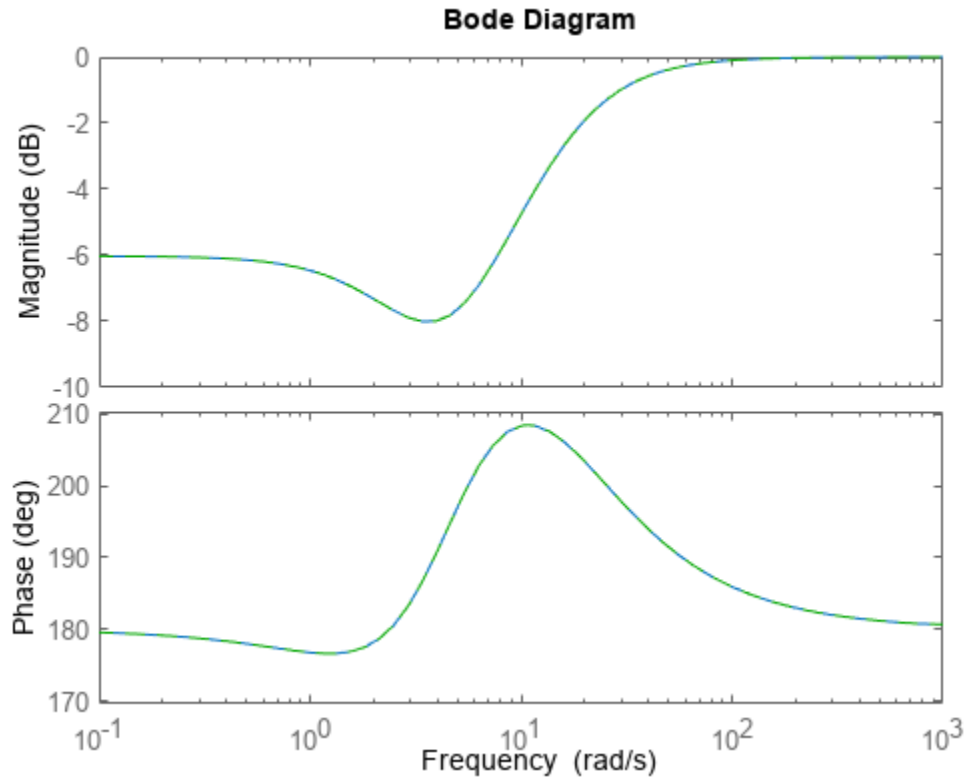

Create State-Space Model with Both Fixed and Tunable Parameters

This example shows how to create a state-space genss model having both fixed and tunable parameters.

$$A = \begin{bmatrix} 1 & a+b \\ 0 & ab \end{bmatrix}, \quad B = \begin{bmatrix} -3.0 \\ 1.5 \end{bmatrix}, \quad C = [0.3 \ 0], \quad D = 0,$$

where a and b are tunable parameters, whose initial values are -1 and 3, respectively.

Create the tunable parameters using `realp`.

```
a = realp('a', -1);
b = realp('b', 3);
```

Define a generalized matrix using algebraic expressions of a and b .

```
A = [1 a+b; 0 a*b];
```

A is a generalized matrix whose `Blocks` property contains a and b . The initial value of A is $\begin{bmatrix} 1 & 2 \\ 0 & -3 \end{bmatrix}$, from the initial values of a and b .

Create the fixed-value state-space matrices.

```
B = [-3.0;1.5];
C = [0.3 0];
D = 0;
```

Use `ss` to create the state-space model.

```
sys = ss(A,B,C,D)
```

```
sys =
```

```
Generalized continuous-time state-space model with 1 outputs, 1 inputs, 2 states, and the following parameters:
a: Scalar parameter, 2 occurrences.
b: Scalar parameter, 2 occurrences.
```

Type `"ss(sys)"` to see the current value, `"get(sys)"` to see all properties, and `"sys.Blocks"` to inspect the blocks.

`sys` is a generalized LTI model (`genss`) with tunable parameters `a` and `b`.

State-Space Model with Input and Output Delay

For this example, consider a SISO state-space model defined by the following state-space matrices:

$$A = \begin{bmatrix} -1.5 & -2 \\ 1 & 0 \end{bmatrix} \quad B = \begin{bmatrix} 0.5 \\ 0 \end{bmatrix} \quad C = [0 \ 1] \quad D = 0$$

Considering an input delay of 0.5 seconds and an output delay of 2.5 seconds, create a state-space model object to represent the A, B, C and D matrices.

```
A = [-1.5, -2; 1, 0];
B = [0.5; 0];
C = [0, 1];
D = 0;
sys = ss(A,B,C,D, 'InputDelay', 0.5, 'OutputDelay', 2.5)
```

```
sys =
```

```
A =
      x1      x2
x1 -1.5    -2
x2  1       0
```

```
B =
      u1
x1  0.5
x2  0
```

```
C =
      x1      x2
y1  0       1
```

```
D =
      u1
y1  0
```

```
Input delays (seconds): 0.5
```

Output delays (seconds): 2.5

Continuous-time state-space model.

You can also use the `get` command to display all the properties of a MATLAB object.

`get(sys)`

```

        A: [2x2 double]
        B: [2x1 double]
        C: [0 1]
        D: 0
        E: []
    Scaled: 0
    StateName: {2x1 cell}
    StatePath: {2x1 cell}
    StateUnit: {2x1 cell}
InternalDelay: [0x1 double]
    InputDelay: 0.5000
    OutputDelay: 2.5000
    InputName: {''}
    InputUnit: {''}
    InputGroup: [1x1 struct]
    OutputName: {''}
    OutputUnit: {''}
    OutputGroup: [1x1 struct]
    Notes: [0x1 string]
    UserData: []
    Name: ''
    Ts: 0
    TimeUnit: 'seconds'
SamplingGrid: [1x1 struct]

```

For more information on specifying time delay for an LTI model, see “Specifying Time Delays”.

Stability Analysis of State-Space Systems

For this example, consider a state-space system object that represents the following state matrices:

$$A = \begin{bmatrix} -1.2 & -1.6 & 0 \\ 1 & 0 & 0 \\ 0 & 1 & 0 \end{bmatrix}, \quad B = \begin{bmatrix} 1 \\ 0 \\ 0 \end{bmatrix}, \quad C = [0 \ 0.5 \ 1.3], \quad D = 0,$$

Create a state-space object `sys` using the `ss` command.

```

A = [-1.2, -1.6, 0; 1, 0, 0; 0, 1, 0];
B = [1; 0; 0];
C = [0, 0.5, 1.3];
D = 0;
sys = ss(A, B, C, D);

```

Next, compute the closed-loop state-space model for a unit negative gain and find the poles of the closed-loop state-space system object `sysFeedback`.

```
sysFeedback = feedback(sys,1);
P = pole(sysFeedback)
```

$P = 3 \times 1$ complex

```
-0.2305 + 1.3062i
-0.2305 - 1.3062i
-0.7389 + 0.0000i
```

The feedback loop for unit gain is stable since all poles have negative real parts. Checking the closed-loop poles provides a binary assessment of stability. In practice, it is more useful to know how robust (or fragile) stability is. One indication of robustness is how much the loop gain can change before stability is lost. You can use the root locus plot to estimate the range of k values for which the loop is stable.

```
rlocus(sys)
```

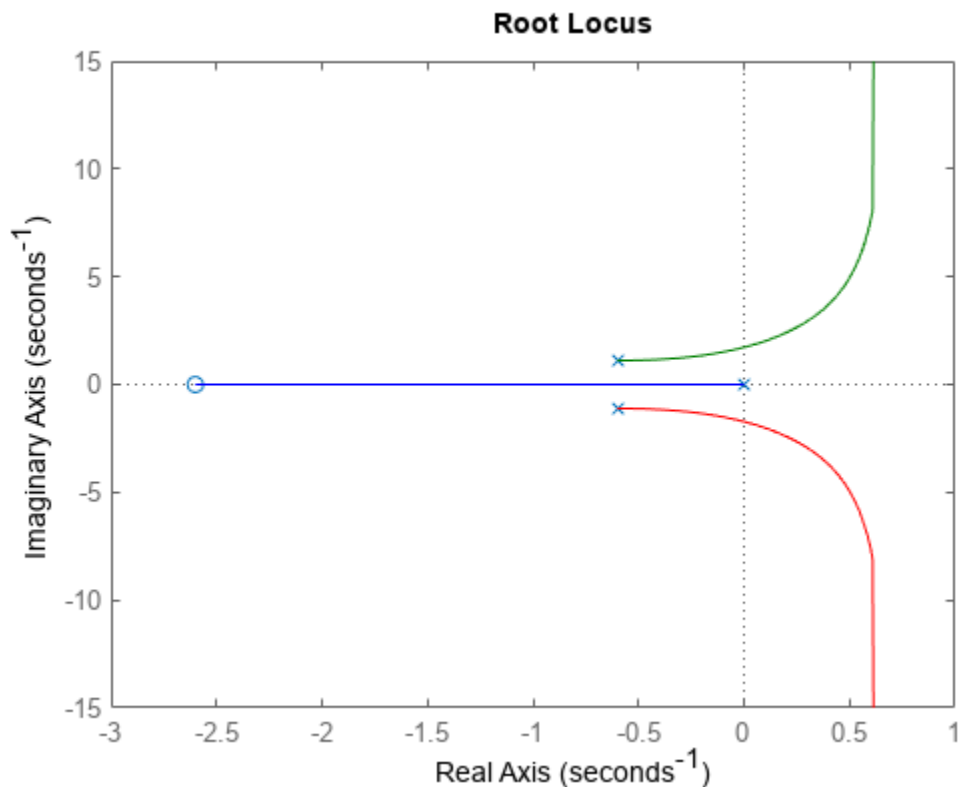

Changes in the loop gain are only one aspect of robust stability. In general, imperfect plant modeling means that both gain and phase are not known exactly. Since modeling errors have the most detrimental effect near the gain crossover frequency (frequency where open-loop gain is 0dB), it also matters how much phase variation can be tolerated at this frequency.

You can display the gain and phase margins on a Bode plot as follows.

```
bode(sys)
grid
```

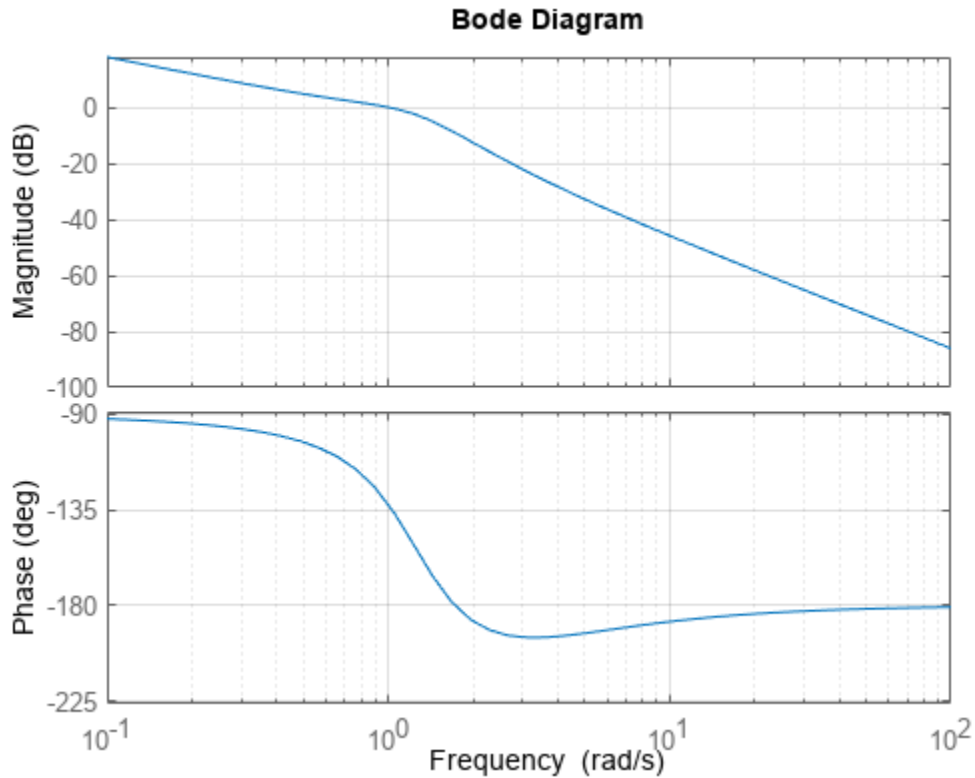

For a more detailed example, see “Assessing Gain and Phase Margins”.

Control Design using State-Space Models

For this example, design a 2-DOF PID controller with a target bandwidth of 0.75 rad/s for a system represented by the following matrices:

$$A = \begin{bmatrix} -0.5 & -0.1 \\ 1 & 0 \end{bmatrix}, \quad B = \begin{bmatrix} 1 \\ 0 \end{bmatrix}, \quad C = [0 \ 1], \quad D = 0.$$

Create a state-space object `sys` using the `ss` command.

```
A = [-0.5, -0.1; 1, 0];
B = [1; 0];
C = [0, 1];
D = 0;
sys = ss(A, B, C, D)
```

```
sys =
```

```
A =
      x1      x2
x1 -0.5  -0.1
x2  1      0
```

```

B =
      u1
x1   1
x2   0

C =
      x1  x2
y1   0   1

D =
      u1
y1   0

```

Continuous-time state-space model.

Using the target bandwidth, use `pidtune` to generate a 2-DOF controller.

```

wc = 0.75;
C2 = pidtune(sys, 'PID2',wc)

```

C2 =

$$u = K_p (b*r-y) + K_i \frac{1}{s} (r-y) + K_d*s (c*r-y)$$

with $K_p = 0.513$, $K_i = 0.0975$, $K_d = 0.577$, $b = 0.344$, $c = 0$

Continuous-time 2-DOF PID controller in parallel form.

Using the type 'PID2' causes `pidtune` to generate a 2-DOF controller, represented as a `pid2` object. The display confirms this result. The display also shows that `pidtune` tunes all controller coefficients, including the setpoint weights b and c , to balance performance and robustness.

For interactive PID tuning in the Live Editor, see the Tune PID Controller Live Editor task. This task lets you interactively design a PID controller and automatically generates MATLAB code for your live script.

For interactive PID tuning in a standalone app, use PID Tuner. See “PID Controller Design for Fast Reference Tracking” for an example of designing a controller using the app.

Connect Specific Inputs and Outputs of State-Space Models in a Feedback Loop

Consider a state-space plant G with five inputs and four outputs and a state-space feedback controller K with three inputs and two outputs. The outputs 1, 3, and 4 of the plant G must be connected the controller K inputs, and the controller outputs to inputs 4 and 2 of the plant.

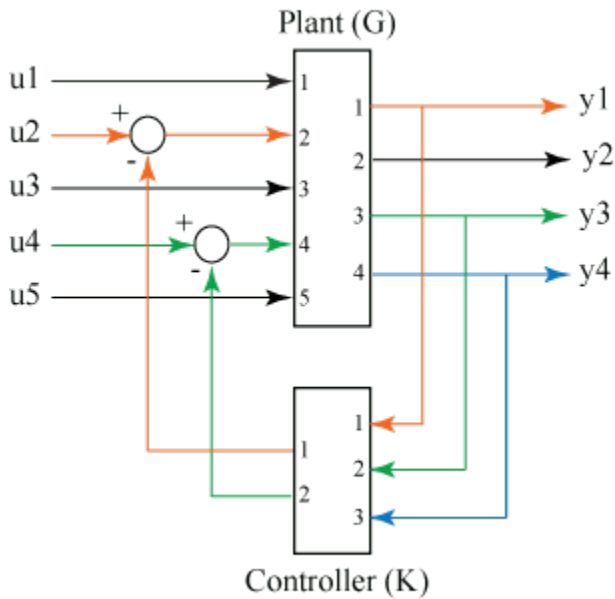

For this example, consider two continuous-time state-space models for both G and K represented by the following set of matrices:

$$A_G = \begin{bmatrix} -3 & 0.4 & 0.3 \\ -0.5 & -2.8 & -0.8 \\ 0.2 & 0.8 & -3 \end{bmatrix}, \quad B_G = \begin{bmatrix} 0.4 & 0 & 0.3 & 0.2 & 0 \\ -0.2 & -1 & 0.1 & -0.9 & -0.5 \\ 0.6 & 0.9 & 0.5 & 0.2 & 0 \end{bmatrix}, \quad C_G = \begin{bmatrix} 0 & -0.1 & -1 \\ 0 & -0.2 & 1.6 \\ -0.7 & 1.5 & 1.2 \\ -1.4 & -0.2 & 0 \end{bmatrix}'$$

$$D_G = \begin{bmatrix} 0 & 0 & 0 & 0 & -1 \\ 0 & 0.4 & -0.7 & 0 & 0.9 \\ 0 & 0.3 & 0 & 0 & 0 \\ 0.2 & 0 & 0 & 0 & 0 \end{bmatrix}$$

$$A_K = \begin{bmatrix} -0.2 & 2.1 & 0.7 \\ -2.2 & -0.1 & -2.2 \\ -0.4 & 2.3 & -0.2 \end{bmatrix}, \quad B_K = \begin{bmatrix} -0.1 & -2.1 & -0.3 \\ -0.1 & 0 & 0.6 \\ 1 & 0 & 0.8 \end{bmatrix}, \quad C_K = \begin{bmatrix} -1 & 0 & 0 \\ -0.4 & -0.2 & 0.3 \end{bmatrix}' \quad D_K$$

$$= \begin{bmatrix} 0 & 0 & 0 \\ 0 & 0 & -1.2 \end{bmatrix}$$

```
AG = [-3,0.4,0.3;-0.5,-2.8,-0.8;0.2,0.8,-3];
BG = [0.4,0,0.3,0.2,0;-0.2,-1,0.1,-0.9,-0.5;0.6,0.9,0.5,0.2,0];
CG = [0,-0.1,-1;0,-0.2,1.6;-0.7,1.5,1.2;-1.4,-0.2,0];
DG = [0,0,0,0,-1;0,0.4,-0.7,0,0.9;0,0.3,0,0,0;0.2,0,0,0,0];
sysG = ss(AG,BG,CG,DG)
```

sysG =

$$A = \begin{array}{c|ccc} & x1 & x2 & x3 \\ \hline x1 & -3 & 0.4 & 0.3 \\ x2 & -0.5 & -2.8 & -0.8 \\ x3 & 0.2 & 0.8 & -3 \end{array}$$

```

B =
      u1      u2      u3      u4      u5
x1  0.4      0      0.3      0.2      0
x2 -0.2     -1      0.1     -0.9     -0.5
x3  0.6      0.9      0.5      0.2      0

```

```

C =
      x1      x2      x3
y1   0     -0.1     -1
y2   0     -0.2     1.6
y3 -0.7     1.5     1.2
y4 -1.4    -0.2      0

```

```

D =
      u1      u2      u3      u4      u5
y1   0      0      0      0     -1
y2   0     0.4    -0.7     0     0.9
y3   0     0.3     0      0      0
y4  0.2     0      0      0      0

```

Continuous-time state-space model.

```

AK = [-0.2,2.1,0.7;-2.2,-0.1,-2.2;-0.4,2.3,-0.2];
BK = [-0.1,-2.1,-0.3;-0.1,0,0.6;1,0,0.8];
CK = [-1,0,0;-0.4,-0.2,0.3];
DK = [0,0,0;0,0,-1.2];
sysK = ss(AK,BK,CK,DK)

```

sysK =

```

A =
      x1      x2      x3
x1 -0.2     2.1     0.7
x2 -2.2    -0.1    -2.2
x3 -0.4     2.3    -0.2

```

```

B =
      u1      u2      u3
x1 -0.1    -2.1    -0.3
x2 -0.1     0      0.6
x3  1       0      0.8

```

```

C =
      x1      x2      x3
y1  -1       0       0
y2 -0.4    -0.2     0.3

```

```

D =
      u1      u2      u3
y1   0       0       0
y2   0       0    -1.2

```

Continuous-time state-space model.

Define the **feedout** and **feedin** vectors based on the inputs and outputs to be connected in a feedback loop.

```

feedin = [4 2];
feedout = [1 3 4];
sys = feedback(sysG,sysK,feedin,feedout,-1)

sys =

A =
      x1      x2      x3      x4      x5      x6
x1      -3      0.4      0.3      0.2      0      0
x2      1.18    -2.56    -0.8     -1.3    -0.2     0.3
x3     -1.312    0.584     -3      0.56    0.18    -0.27
x4      2.948    -2.929    -2.42   -0.452   1.974    0.889
x5     -0.84    -0.11     0.1     -2.2    -0.1    -2.2
x6     -1.12    -0.26     -1     -0.4     2.3    -0.2

B =
      u1      u2      u3      u4      u5
x1      0.4      0      0.3      0.2      0
x2     -0.44     -1      0.1     -0.9    -0.5
x3      0.816     0.9      0.5      0.2      0
x4     -0.2112   -0.63      0      0      0.1
x5      0.12      0      0      0      0.1
x6      0.16      0      0      0     -1

C =
      x1      x2      x3      x4      x5      x6
y1      0     -0.1     -1      0      0      0
y2    -0.672   -0.296     1.6     0.16    0.08   -0.12
y3    -1.204     1.428     1.2     0.12    0.06   -0.09
y4     -1.4     -0.2      0      0      0      0

D =
      u1      u2      u3      u4      u5
y1      0      0      0      0     -1
y2    0.096     0.4    -0.7      0     0.9
y3    0.072     0.3      0      0      0
y4     0.2      0      0      0      0

```

Continuous-time state-space model.

```
size(sys)
```

State-space model with 4 outputs, 5 inputs, and 6 states.

`sys` is the resultant closed loop state-space model obtained by connecting the specified inputs and outputs of `G` and `K`.

Version History

Introduced before R2006a

See Also

`dss` | `frd` | `get` | `set` | `ssdata` | `tf` | `zpk`

Topics

“Dynamic System Models”

“What Are Model Objects?”
“State-Space Models”
“MIMO State-Space Models”
“State-Space Realizations”
“Recommended Working Representation”
“Time Delays in Linear Systems”
“Specifying Time Delays”

ss2ss

State coordinate transformation for state-space model

Syntax

```
sysT = ss2ss(sys,T)
```

Description

`ss2ss` performs the similarity transformation $z = Tx$ on the state vector x of a state-space model. For more information, see “Algorithms” on page 2-1277.

`sysT = ss2ss(sys,T)` performs the state-coordinate transformation of `sys` using the specified transformation matrix `T`. The matrix `T` must be invertible.

Examples

Similarity Transformation for State-Space Model

Perform a similarity transform for a state space model.

Generate a random state-space model and a transformation matrix.

```
rng(0)
sys = rss(5);
t = randn(5);
```

Perform the transformation and plot the frequency response of both models.

```
tsys = ss2ss(sys,t);
bode(sys,'b',tsys,'r--')
legend
```

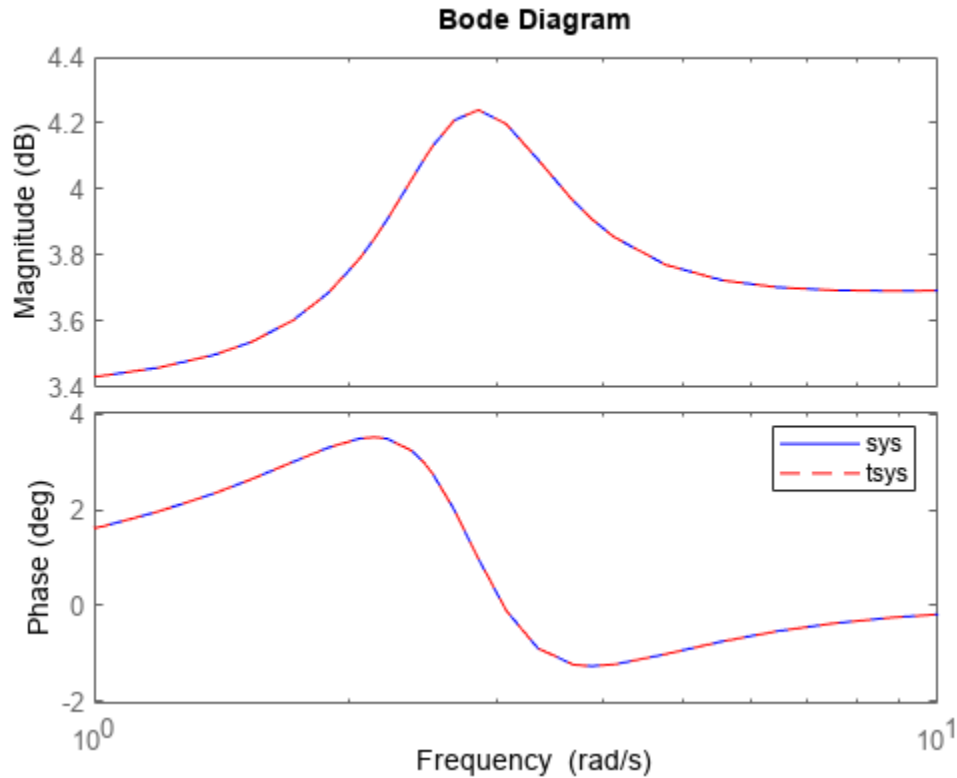

The responses of both models match closely.

Similarity Transformation for Generalized State-Space Models

ss2ss applies state transformation only to the state vectors of the numeric portion of the generalized model.

Create a genss model.

```
sys = rss(2,2,2) * tunableSS('a',2,2,3) + tunableGain('b',2,3)
```

```
sys =
```

```
Generalized continuous-time state-space model with 2 outputs, 3 inputs, 4 states, and the following
```

```
  a: Tunable 2x3 state-space model, 2 states, 1 occurrences.
```

```
  b: Tunable 2x3 gain, 1 occurrences.
```

```
Type "ss(sys)" to see the current value, "get(sys)" to see all properties, and "sys.Blocks" to inspect
```

Specify a transformation matrix and obtain the transformation.

```
T = [1 -2;3 5];
```

```
tsys = ss2ss(sys,T)
```

```
tsys =
```

Generalized continuous-time state-space model with 2 outputs, 3 inputs, 4 states, and the following blocks:
a: Tunable 2x3 state-space model, 2 states, 1 occurrences.
b: Tunable 2x3 gain, 1 occurrences.

Type "ss(tsys)" to see the current value, "get(tsys)" to see all properties, and "tsys.Blocks" to see the blocks.

Decompose both models.

```
[H,B,~,~] = getLFTModel(sys);  
[H1,B1,~,~] = getLFTModel(tsys);
```

Obtain the transformation separately on the model from decomposed sys.

```
H2 = ss2ss(H,T);
```

Compare this transformed model with the model from decomposed tsys.

```
isequal(H1,H2)
```

```
ans = logical  
     1
```

Both models are equal.

Similarity Transformation for Identified State-Space Models

The file `icEngine.mat` contains one data set with 1500 input-output samples collected at the a sampling rate of 0.04 seconds. The input $u(t)$ is the voltage (V) controlling the By-Pass Idle Air Valve (BPAV), and the output $y(t)$ is the engine speed (RPM/100).

Use the data in `icEngine.mat` to create a state-space model with identifiable parameters.

```
load icEngine.mat  
z = iddata(y,u,0.04);  
sys = n4sid(z,4,'InputDelay',2);
```

Specify a random transformation matrix.

```
T = randn(4);
```

Obtain the transformation.

```
sysT = ss2ss(sys,T);
```

Compare the frequency responses.

```
bode(sys,'b',sysT,'r--')  
legend
```

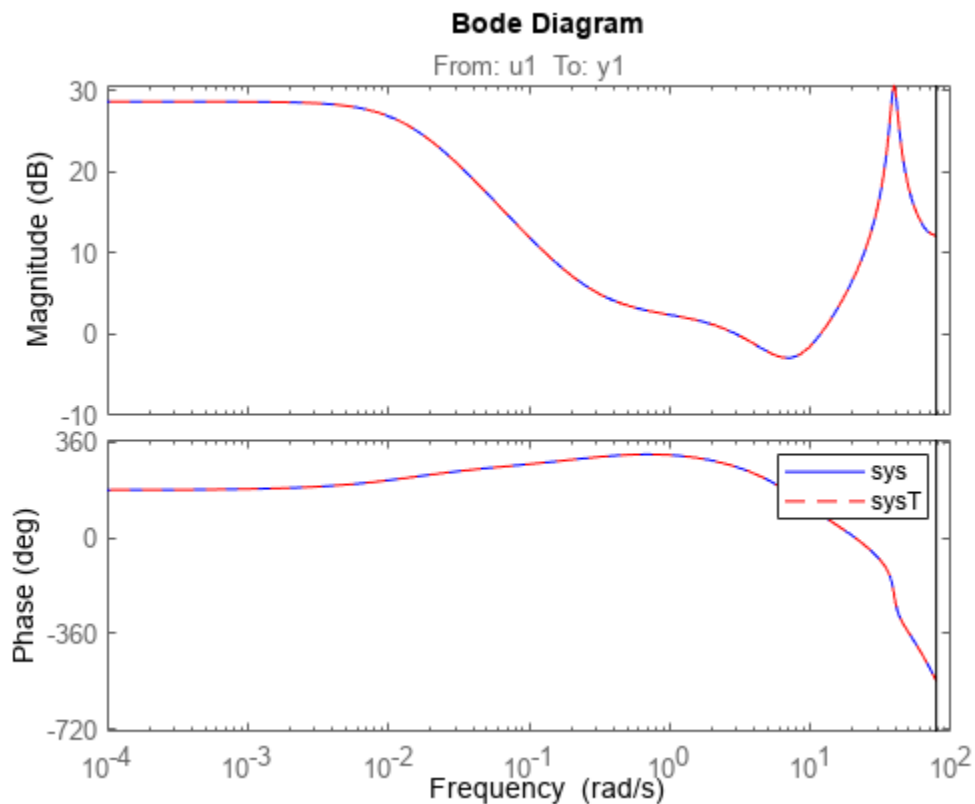

The responses match closely.

Transformation for Models with Complex Coefficients

ss2ss also lets you perform similarity transformation for models with complex coefficients.

For this example, generate a random state-space model with complex coefficients.

```
rng(0)
sys = ss(randn(5)+1i*randn(5), randn(5,3), randn(2,5)+1i*randn(2,5), 0, .1);
```

Specify a transformation matrix containing complex data.

```
T = randn(5)+1i*randn(5);
```

Obtain the transformation.

```
sysT = ss2ss(sys,T);
```

Compare the singular values of the frequency response.

```
sigma(sys, 'b', sysT, 'r--')
legend
```

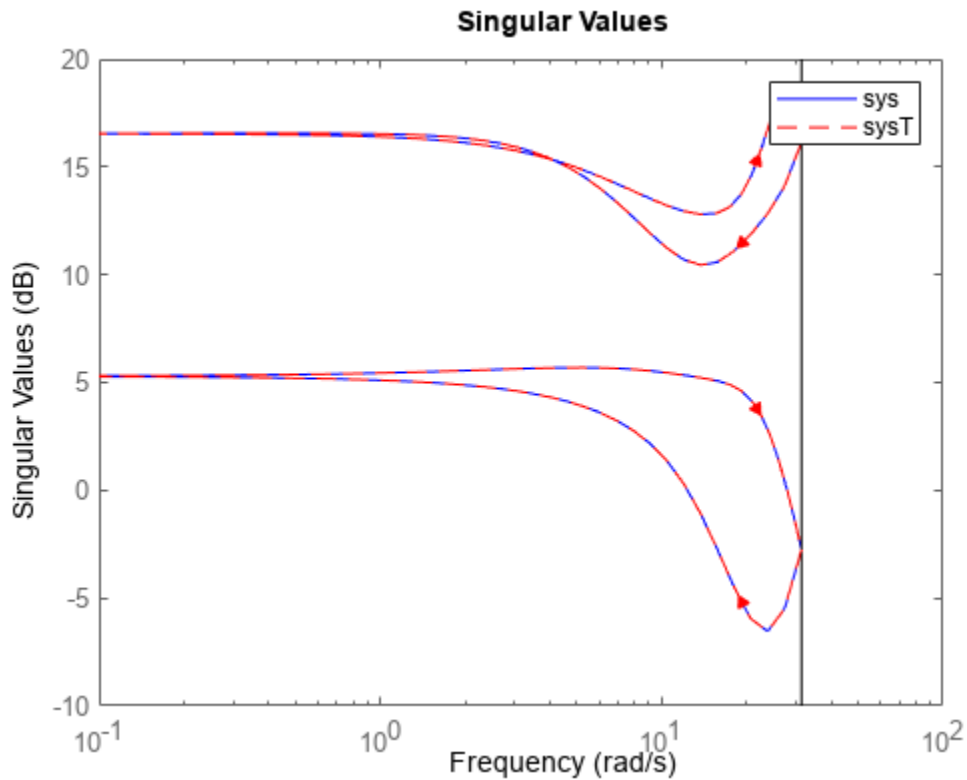

The responses match closely for both branches.

Input Arguments

sys — Dynamic system

dynamic system model

Dynamic system, specified as a SISO, or MIMO dynamic system model. Dynamic systems that you can use include:

- Continuous-time or discrete-time numeric LTI models, such as `ss` or `dss` models.
- Generalized or uncertain LTI models, such as `genss` or `uss` models. (Using uncertain models requires Robust Control Toolbox software.)

For such models, the state transformation is applied only to the state vectors of the numeric portion of the model. For more information about decomposition of these models, see `getLFTModel` and “Internal Structure of Generalized Models”.

- Identified state-space `idss` models. (Using identified models requires System Identification Toolbox software.)

If `sys` is an array of state-space models, `ss2ss` applies the transformation `T` to each individual model in the array.

T – Transformation matrix
matrix

Transformation matrix, specified as an n -by- n matrix, where n is the number of states. T is the transformation between the state vector of the state-space model `sys` and the state vector of the transformed model `sysT`. (See “Algorithms” on page 2-1277.)

Output Arguments

sysT – Transformed model
dynamic system model

Transformed state-space model, returned as a dynamic system model of the same type as `sys`.

Algorithms

`ss2ss` performs the similarity transformation $\bar{x} = T x$ on the state vector x of a state-space model.

This table summarizes the transformations returned by `ss2ss` for each model form.

Input Model	Transformed Model
Explicit state-space models of the form: $\dot{x} = Ax + Bu$ $y = Cx + Du$	$\dot{\bar{x}} = TAT^{-1}\bar{x} + TBu$ $y = CT^{-1}\bar{x} + Du$
Descriptor (implicit) state-space models for the form: $E\dot{x} = Ax + Bu$ $y = Cx + Du$	$ET^{-1}\dot{\bar{x}} = AT^{-1}\bar{x} + Bu$ $y = CT^{-1}\bar{x} + Du$
Identified state-space (<code>idss</code>) models of the form: $\frac{dx}{dt} = Ax + Bu + Ke$ $y = Cx + Du + e$	$\dot{\bar{x}} = TAT^{-1}\bar{x} + TBu + TKe$ $y = CT^{-1}\bar{x} + Du + e$

Version History

Introduced before R2006a

ss2ss returns different transformation results for descriptor state-space models

Behavior changed in R2021b

For a descriptor state-space model

$$E\dot{x} = Ax + Bu$$

$$y = Cx + Du,$$

`ss2ss` now returns

$$ET^{-1}\dot{\bar{x}} = AT^{-1}\bar{x} + Bu$$

$$y = CT^{-1}\bar{x} + Du.$$

Previously, the function returned the following transformation.

$$TET^{-1}\dot{\bar{x}} = TAT^{-1}\bar{x} + TBu$$

$$y = CT^{-1}\bar{x} + Du$$

Similarity transformation is no longer supported for mechss models

Errors starting in R2021b

ss2ss no longer supports sparse second-order (mechss) models. Performing similarity transformations on mechss models destroys symmetry and has no obvious general form.

See Also

balreal | canon | balance

Topics

“Scaling State-Space Models to Maximize Accuracy”

ssdata

Access state-space model data

Syntax

```
[a,b,c,d] = ssdata(sys)
[a,b,c,d,Ts] = ssdata(sys)
```

Description

`[a,b,c,d] = ssdata(sys)` extracts the matrix (or multidimensional array) data A, B, C, D from the state-space model (LTI array) `sys`. If `sys` is a transfer function or zero-pole-gain model (LTI array), it is first converted to state space. See `ss` for more information on the format of state-space model data.

If `sys` appears in descriptor form (nonempty E matrix), an equivalent explicit form is first derived.

If `sys` has internal delays, A, B, C, D are obtained by first setting all internal delays to zero (creating a zero-order Padé approximation). For some systems, setting delays to zero creates singular algebraic loops, which result in either improper or ill-defined, zero-delay approximations. For these systems, `ssdata` cannot display the matrices and returns an error. This error does not imply a problem with the model `sys` itself.

For generalized state-space (`genss`) models, `ssdata` returns the state-space models evaluated at the current, nominal value of all control design blocks. To access the dependency of a `genss` model on its static control design blocks, use the A, B, C, and D properties of the model.

`[a,b,c,d,Ts] = ssdata(sys)` also returns the sample time `Ts`.

You can access the remaining LTI properties of `sys` with `get` or by direct referencing. For example:

```
sys.statename
```

For arrays of state-space models with variable numbers of states, use the syntax:

```
[a,b,c,d] = ssdata(sys,'cell')
```

to extract the state-space matrices of each model as separate cells in the cell arrays `a`, `b`, `c`, and `d`.

Version History

Introduced before R2006a

See Also

`dssdata` | `get` | `getDelayModel` | `set` | `ss` | `tfdata` | `zpkdata`

stabsep

Stable-unstable decomposition

Syntax

```
[GS,GNS]=stabsep(G)
[G1,GNS] = stabsep(G,'abstol',ATOL,'reltol',RTOL)
[G1,G2]=stabsep(G, ..., 'Mode', MODE, 'Offset', ALPHA)
[G1,G2] = stabsep(G, opts)
```

Description

`[GS,GNS]=stabsep(G)` decomposes the LTI model G into its stable and unstable parts

$$G = GS + GNS$$

where GS contains all stable modes that can be separated from the unstable modes in a numerically stable way, and GNS contains the remaining modes. GNS is always strictly proper.

`[G1,GNS] = stabsep(G, 'abstol', ATOL, 'reltol', RTOL)` specifies absolute and relative error tolerances for the stable/unstable decomposition. The frequency responses of G and $GS + GNS$ should differ by no more than $ATOL + RTOL * \text{abs}(G)$. Increasing these tolerances helps separate nearby stable and unstable modes at the expense of accuracy. The default values are $ATOL=0$ and $RTOL=1e-8$.

`[G1,G2]=stabsep(G, ..., 'Mode', MODE, 'Offset', ALPHA)` produces a more general stable/unstable decomposition where $G1$ includes all separable poles lying in the regions defined using offset $ALPHA$. This can be useful when there are numerical accuracy issues. For example, if you have a pair of poles close to, but slightly to the left of the $j\omega$ -axis, you can decide not to include them in the stable part of the decomposition if numerical considerations lead you to believe that the poles may be in fact unstable

This table lists the stable/unstable boundaries as defined by the offset $ALPHA$.

Mode	Continuous Time Region	Discrete Time Region
1	$\text{Re}(s) < -ALPHA * \max(1, \text{Im}(s))$	1 $ z < 1 - ALPHA$
2	$\text{Re}(s) > ALPHA * \max(1, \text{Im}(s))$	2 $ z > 1 + ALPHA$

The default values are $MODE=1$ and $ALPHA=0$.

`[G1,G2] = stabsep(G, opts)` computes the stable/unstable decomposition of G using the options specified in the `stabsepOptions` object `opts`.

Examples

Compute a stable/unstable decomposition with absolute error no larger than $1e-5$ and an offset of 0.1:

```
h = zpk(1,[-2 -1 1 -0.001],0.1)
[hs,hns] = stabsep(h,stabsepOptions('AbsTol',1e-5,'Offset',0.1));
```

The stable part of the decomposition has poles at -1 and -2.

hs

```
Zero/pole/gain:  
-0.050075 (s+2.999)  
-----  
      (s+1) (s+2)
```

The unstable part of the decomposition has poles at +1 and -.001 (which is nominally stable).

hns

```
Zero/pole/gain:  
0.050075 (s-1)  
-----  
      (s+0.001) (s-1)
```

Version History

Introduced before R2006a

See Also

stabsepOptions | modsep

stabsepOptions

Options for stable-unstable decomposition

Syntax

```
opts = stabsepOptions
opts = stabsepOptions('OptionName', OptionValue)
```

Description

`opts = stabsepOptions` returns the default options for the `stabsep` command.

`opts = stabsepOptions('OptionName', OptionValue)` accepts one or more comma-separated name/value pairs. Specify *OptionName* inside single quotes.

Input Arguments

Name-Value Pair Arguments

Focus

Focus of decomposition. Specified as one of the following values:

'stable'	First output of <code>stabsep</code> contains only stable dynamics.
'unstable'	First output of <code>stabsep</code> contains only unstable dynamics.

Default: 'stable'

SepTol

Accuracy loss factor for stable/unstable decomposition. Positive scalar values. When decomposing a model $G(s)$, `stabsep` ensures that the frequency responses of G and $G1 + G2$ differ by no more than `SepTol` times the absolute accuracy of the computed value of $G(s)$. Increasing `SepTol` helps separate nearby stable and unstable modes at the expense of accuracy.

Default: 10

Offset

Offset for the stable/unstable boundary. Positive scalar value. The first output of `stabsep` includes only poles satisfying:

Continuous time:

- $\text{Re}(s) < -\text{Offset} * \max(1, |\text{Im}(s)|)$ (Focus = 'stable')
- $\text{Re}(s) > \text{Offset} * \max(1, |\text{Im}(s)|)$ (Focus = 'unstable')

Discrete time:

- $|z| < 1 - \text{Offset}$ (Focus = 'stable')
- $|z| > 1 + \text{Offset}$ (Focus = 'unstable')

Increase the value of `Offset` to treat poles close to the stability boundary as unstable.

Default: 0

For additional information on the options and how to use them, see the `stabsep` reference page.

Examples

Compute the stable/unstable decomposition of the system given by:

$$G(s) = \frac{10(s + 0.5)}{(s + 10^{-6})(s + 2 - 5i)(s + 2 + 5i)}$$

Use the `Offset` option to force `stabsep` to exclude the pole at $s = 10^{-6}$ from the stable term of the stable/unstable decomposition.

```
G = zpk(-.5,[-1e-6 -2+5i -2-5i],10);
opts = stabsepOptions('Offset',.001); % Create option set
[G1,G2] = stabsep(G,opts) % treats -1e-6 as unstable
```

These commands return the result:

```
Zero/pole/gain:
-0.17241 (s-54)
-----
(s^2 + 4s + 29)
```

```
Zero/pole/gain:
0.17241
-----
(s+1e-006)
```

The pole at $s = 10^{-6}$ is in the second (unstable) output.

Version History

Introduced in R2010a

See Also

`stabsep`

stack

Build model array by stacking models or model arrays along array dimensions

Syntax

```
sys = stack(arraydim,sys1,sys2,...)
```

Description

`sys = stack(arraydim,sys1,sys2,...)` produces an array of dynamic system models `sys` by stacking (concatenating) the models (or arrays) `sys1,sys2,...` along the array dimension `arraydim`. All models must have the same number of inputs and outputs (the same I/O dimensions), but the number of states can vary. The I/O dimensions are not counted in the array dimensions. For more information about model arrays and array dimensions, see “Model Arrays”.

For arrays of state-space models with variable order, you cannot use the dot operator (e.g., `sys.A`) to access arrays. Use the syntax

```
[A,B,C,D] = ssdata(sys,'cell')
```

to extract the state-space matrices of each model as separate cells in the cell arrays `A`, `B`, `C`, and `D`.

Examples

Example 1

If `sys1` and `sys2` are two models:

- `stack(1,sys1,sys2)` produces a 2-by-1 model array.
- `stack(2,sys1,sys2)` produces a 1-by-2 model array.
- `stack(3,sys1,sys2)` produces a 1-by-1-by-2 model array.

Example 2

Stack identified state-space models derived from the same estimation data and compare their bode responses.

```
load iddata1 z1
sysc = cell(1,5);
opt = ssestOptions('Focus','simulation');
for i = 1:5
    sysc{i} = ssest(z1,i-1,opt);
end
sysArray = stack(1, sysc{:});
bode(sysArray);
```

Version History

Introduced before R2006a

step

Step response plot of dynamic system; step response data

Syntax

```

step(sys)
step(sys,tFinal)
step(sys,t)
step(sys1,sys2,...,sysN,___)
step(sys1,LineStyle1,...,sysN,LineStyleN,___)
step(___,opts)

y = step(sys,t)
[y,tOut] = step(sys)
[y,tOut] = step(sys,tFinal)
[y,t,x] = step(sys)
[y,t,x,ysd] = step(sys)
[___] = step(___,opts)

```

Description

Step Response Plots

`step(sys)` plots the response of a dynamic system model to a step input of unit amplitude. The model `sys` can be continuous- or discrete-time, and SISO or MIMO. For MIMO systems, the plot displays the step responses for each I/O channel. `step` automatically determines the time steps and duration of the simulation based on the system dynamics.

`step(sys,tFinal)` simulates the step response from $t = 0$ to the final time $t = tFinal$. The function uses system dynamics to determine the intervening time steps.

`step(sys,t)` plots the step response at the times that you specify in the vector `t`.

`step(sys1,sys2,...,sysN,___)` plots the step response of multiple dynamic systems on the same plot. All systems must have the same number of inputs and outputs. You can use multiple dynamic systems with any of the previous input-argument combinations.

`step(sys1,LineStyle1,...,sysN,LineStyleN,___)` specifies a color, line style, and marker for each system in the plot. You can use `LineStyle` with any of the previous input-argument combinations. When you need additional plot customization options, use `stepplot` instead.

`step(___,opts)` specifies additional options for computing the step response, such as the step amplitude or input offset. Use `stepDataOptions` to create the option set `opts`. You can use `opts` with any of the previous input-argument and output-argument combinations.

Step Response Data

`y = step(sys,t)` returns the step response of a dynamic system model `sys` at the times specified in the vector `t`. This syntax does not draw a plot.

`[y,tOut] = step(sys)` also returns a vector of times `tOut` corresponding to the responses in `y`. If you do not provide an input vector `t` of times, `step` chooses the length and time step of `tOut` based on the system dynamics.

`[y,tOut] = step(sys,tFinal)` computes the step response up to the end time `tFinal`. `step` chooses the time step of `tOut` based on the system dynamics.

`[y,t,x] = step(sys)` also returns the state trajectories `x`, when `sys` is a state-space model such as an `ss` or `idss` model.

`[y,t,x,ysd] = step(sys)` also computes the standard deviation `ysd` of the step response `y`, when `sys` is an identified model such as an `idss`, `idtf`, or `idnlarx` model.

`[___] = step(___ ,opts)` specifies additional options for computing the step response, such as the step amplitude or input offset. Use `stepDataOptions` to create the option set `opts`. You can use `opts` with any of the previous input-argument and output-argument combinations.

Examples

Step Response of Dynamic System

Plot the step response of a continuous-time system represented by the following transfer function.

$$\text{sys}(s) = \frac{4}{s^2 + 2s + 10}.$$

For this example, create a `tf` model that represents the transfer function. You can similarly plot the step response of other dynamic system model types, such as zero-pole gain (`zpk`) or state-space (`ss`) models.

```
sys = tf(4,[1 2 10]);
```

Plot the step response.

```
step(sys)
```

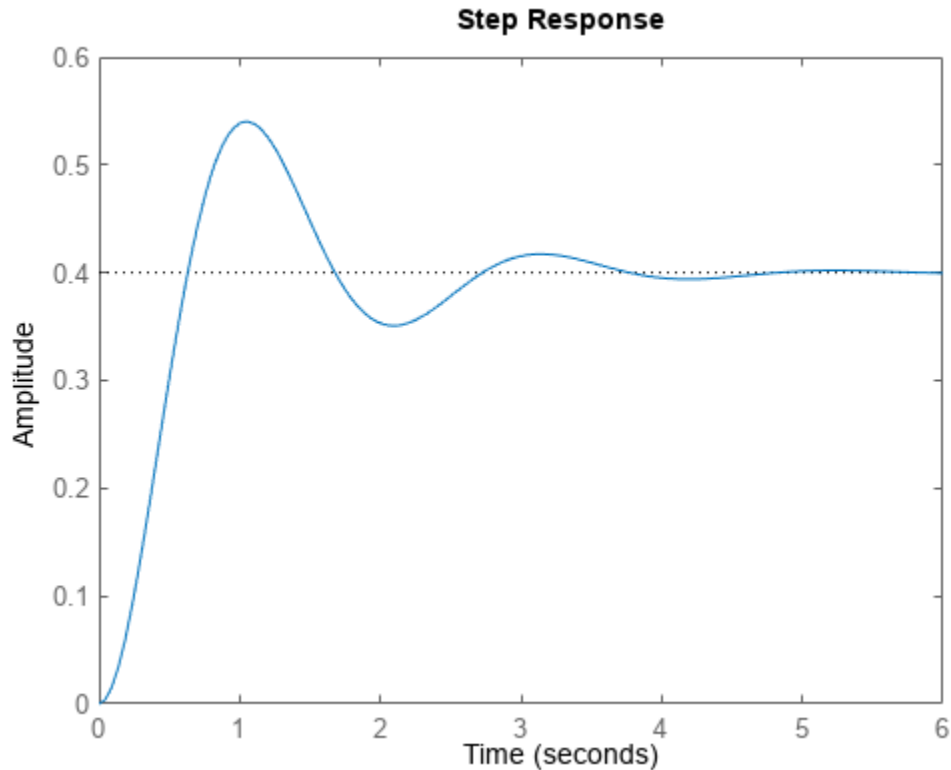
The `step` plot automatically includes a dotted horizontal line indicating the steady-state response. In a MATLAB® figure window, you can right-click on the plot to view other step-response characteristics such as peak response and settling time. For more information about these characteristics, see `stepinfo`.

Step Response of Discrete-Time System

Plot the step response of a discrete-time system. The system has a sample time of 0.2 s and is represented by the following state-space matrices.

```
A = [1.6 -0.7;  
      1  0];  
B = [0.5; 0];  
C = [0.1 0.1];  
D = 0;
```

Create the state-space model and plot its step response.

```
sys = ss(A,B,C,D,0.2);  
step(sys)
```

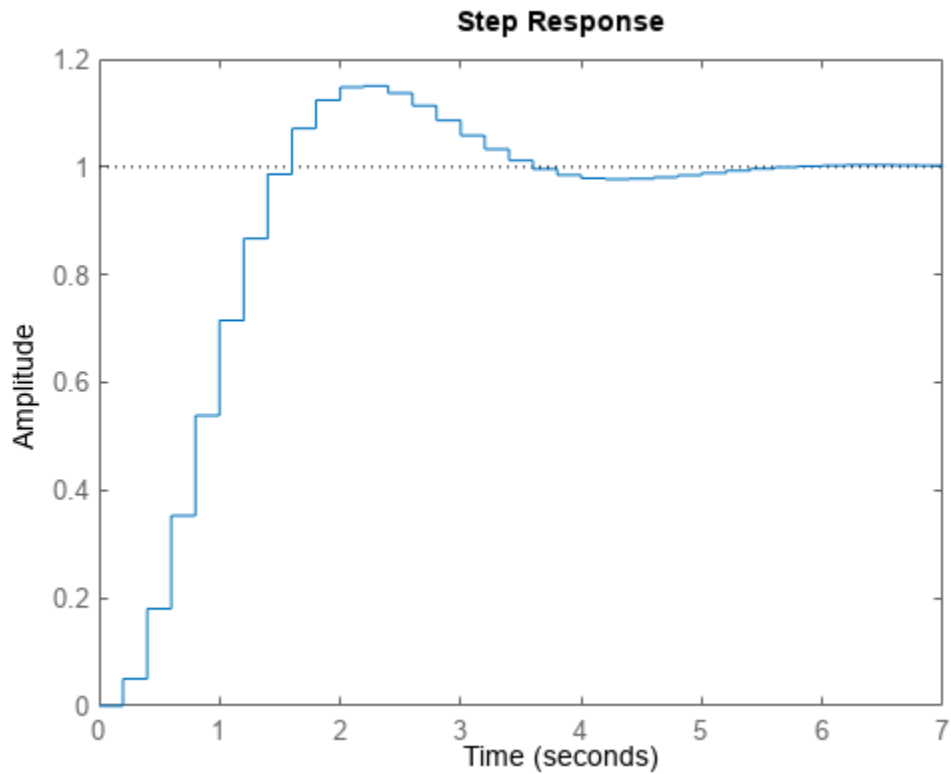

The step response reflects the discretization of the model, showing the response computed every 0.2 seconds.

Step Response at Specified Times

Examine the step response of the following transfer function.

```
sys = zpk(-1,[-0.2+3j,-0.2-3j],1) * tf([1 1],[1 0.05])
```

```
sys =
```

$$\frac{(s+1)^2}{(s+0.05)(s^2 + 0.4s + 9.04)}$$

Continuous-time zero/pole/gain model.

```
step(sys)
```

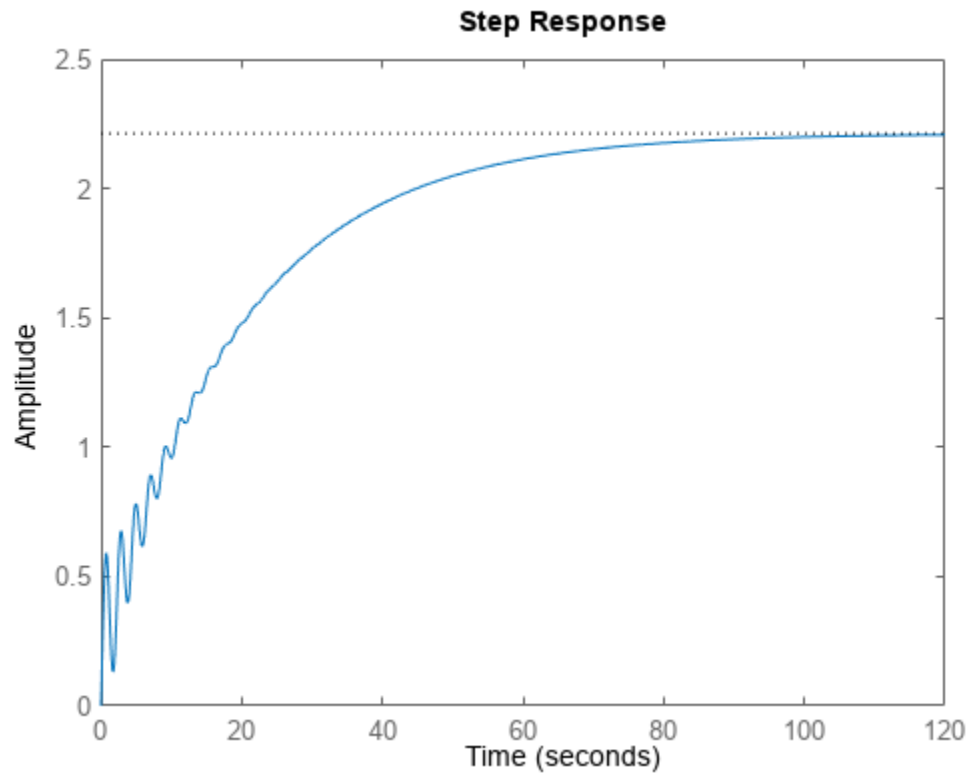

By default, `step` chooses an end time that shows the steady state that the response is trending toward. This system has fast transients, however, which are obscured on this time scale. To get a closer look at the transient response, limit the step plot to $t = 15$ s.

```
step(sys,15)
```

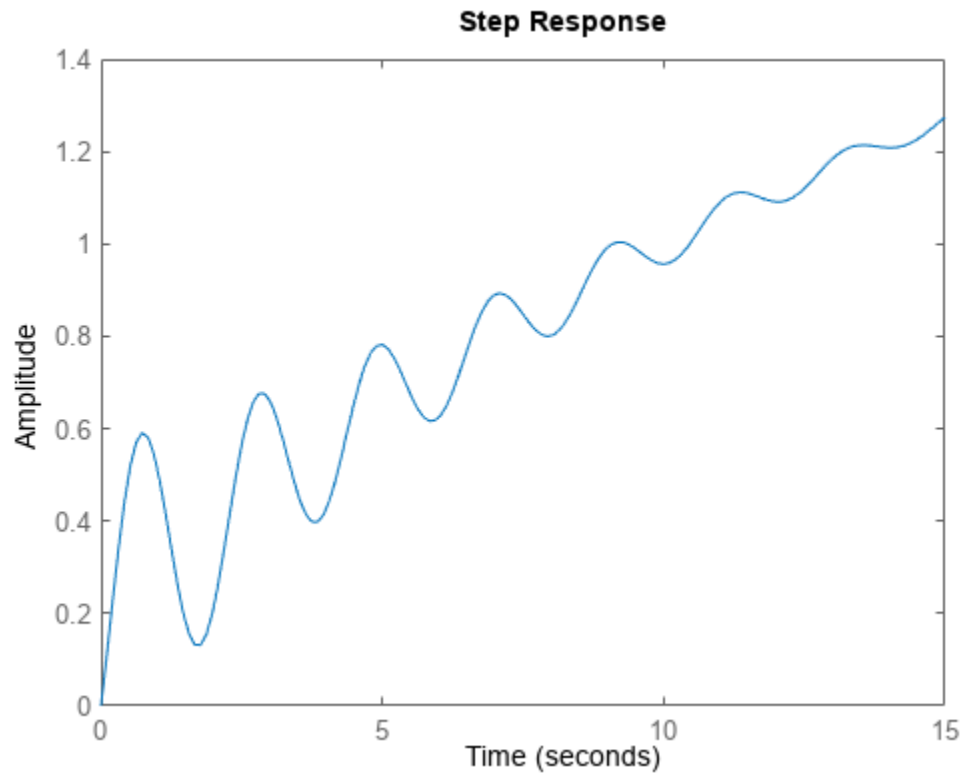

Alternatively, you can specify the exact times at which you want to examine the step response, provided they are separated by a constant interval. For instance, examine the response from the end of the transient until the system reaches steady state.

```
t = 20:0.2:120;  
step(sys,t)
```

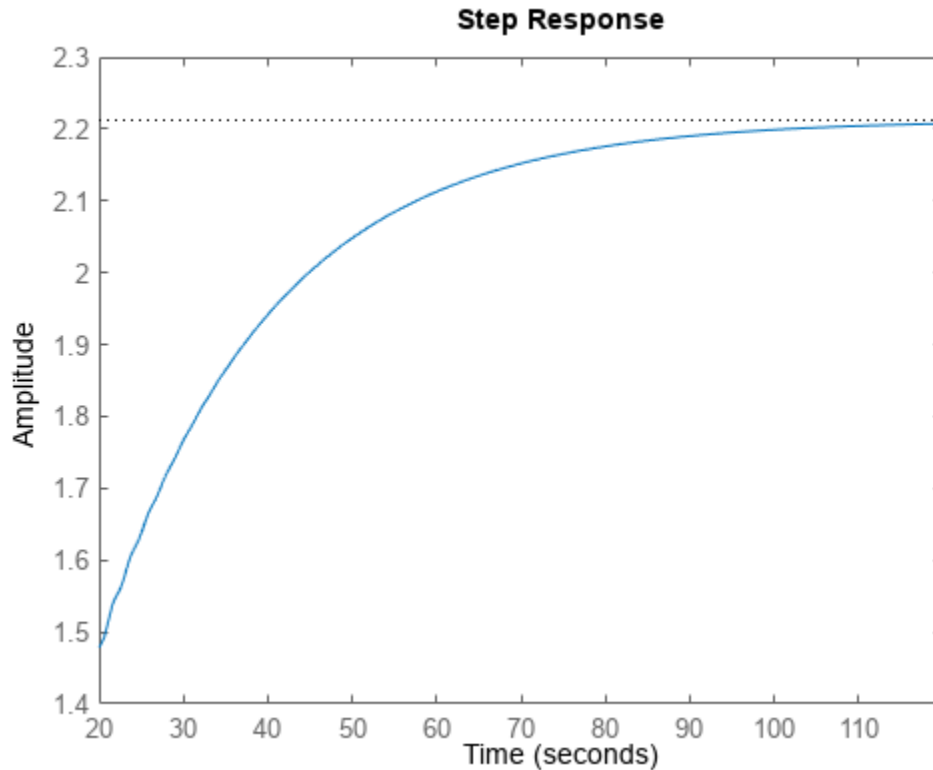

Even though this plot begins at $t = 20$, `step` always applies the step input at $t = 0$.

Step Response Plot of MIMO Systems

Consider the following second-order state-space model:

$$\begin{bmatrix} \dot{x}_1 \\ \dot{x}_2 \end{bmatrix} = \begin{bmatrix} -0.5572 & -0.7814 \\ 0.7814 & 0 \end{bmatrix} \begin{bmatrix} x_1 \\ x_2 \end{bmatrix} + \begin{bmatrix} 1 & -1 \\ 0 & 2 \end{bmatrix} \begin{bmatrix} u_1 \\ u_2 \end{bmatrix}$$

$$y = [1.9691 \ 6.4493] \begin{bmatrix} x_1 \\ x_2 \end{bmatrix}$$

`A = [-0.5572, -0.7814; 0.7814, 0];`

`B = [1, -1; 0, 2];`

`C = [1.9691, 6.4493];`

`sys = ss(A,B,C,0);`

This model has two inputs and one output, so it has two channels: from the first input to the output, and from the second input to the output. Each channel has its own step response.

When you use `step`, it computes the responses of all channels.

`step(sys)`

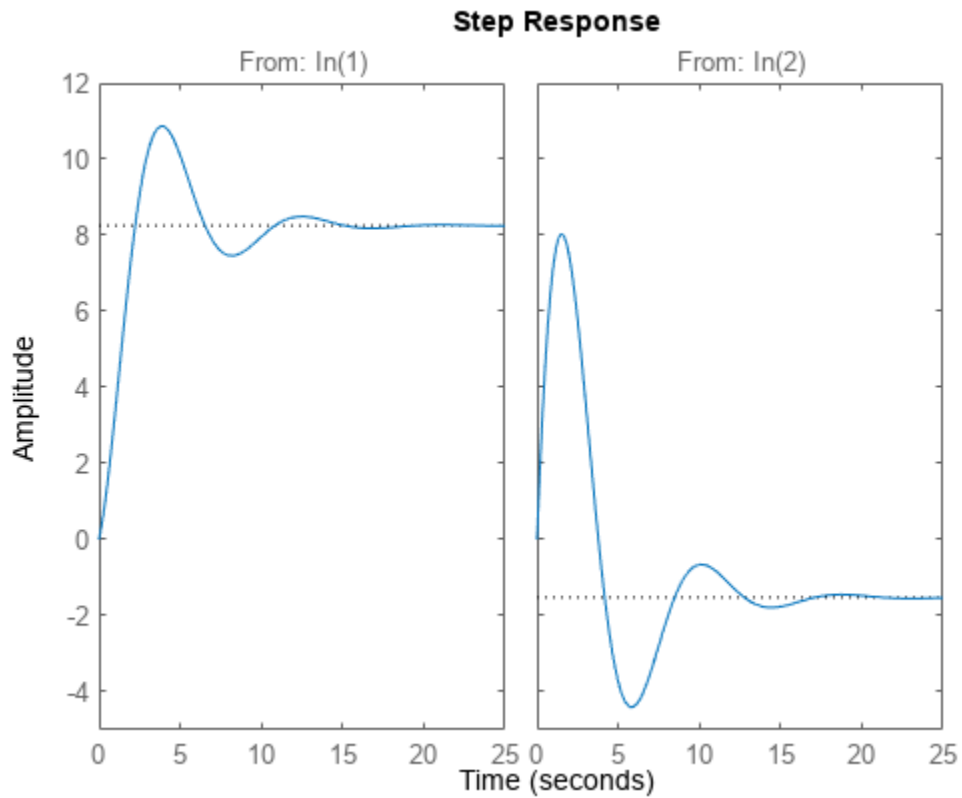

The left plot shows the step response of the first input channel, and the right plot shows the step response of the second input channel. Whenever you use `step` to plot the responses of a MIMO model, it generates an array of plots representing all the I/O channels of the model. For instance, create a random state-space model with five states, three inputs, and two outputs, and plot its step response.

```
sys = rss(5,2,3);  
step(sys)
```

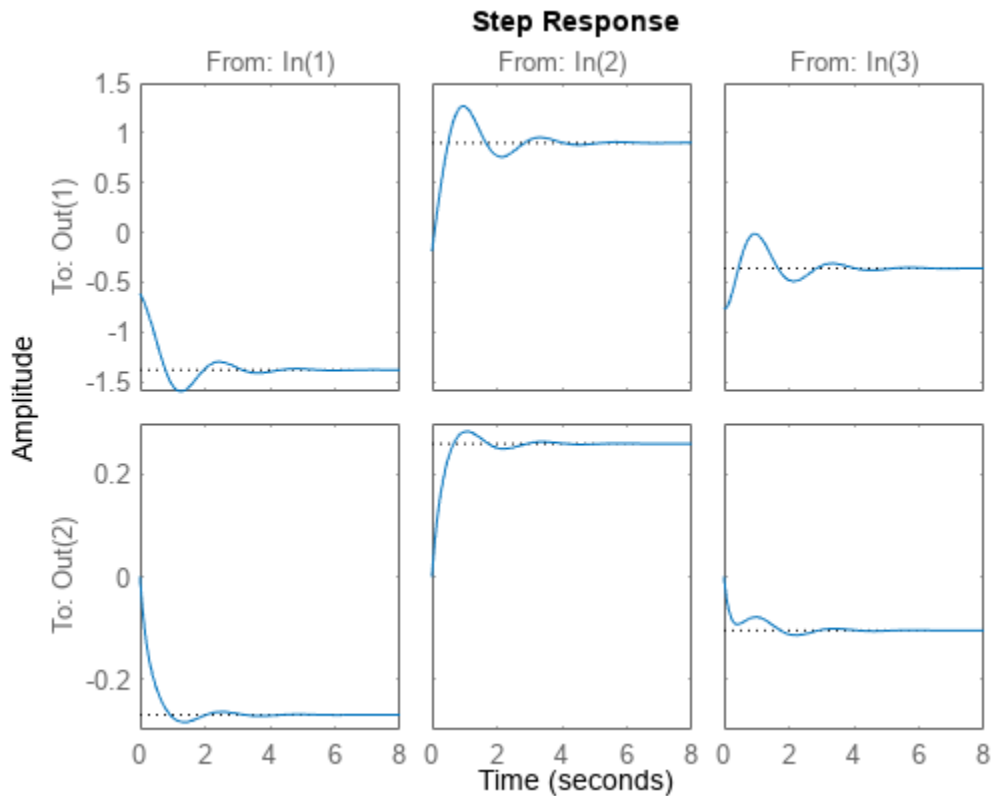

In a MATLAB figure window, you can restrict the plot to a subset of channels by right-clicking on the plot and selecting **I/O Selector**.

Compare Responses of Multiple Systems

`step` allows you to plot the responses of multiple dynamic systems on the same axis. For instance, compare the closed-loop response of a system with a PI controller and a PID controller. Create a transfer function of the system and tune the controllers.

```
H = tf(4,[1 2 10]);
C1 = pidtune(H,'PI');
C2 = pidtune(H,'PID');
```

Form the closed-loop systems and plot their step responses.

```
sys1 = feedback(H*C1,1);
sys2 = feedback(H*C2,1);
step(sys1,sys2)
legend('PI','PID','Location','SouthEast')
```

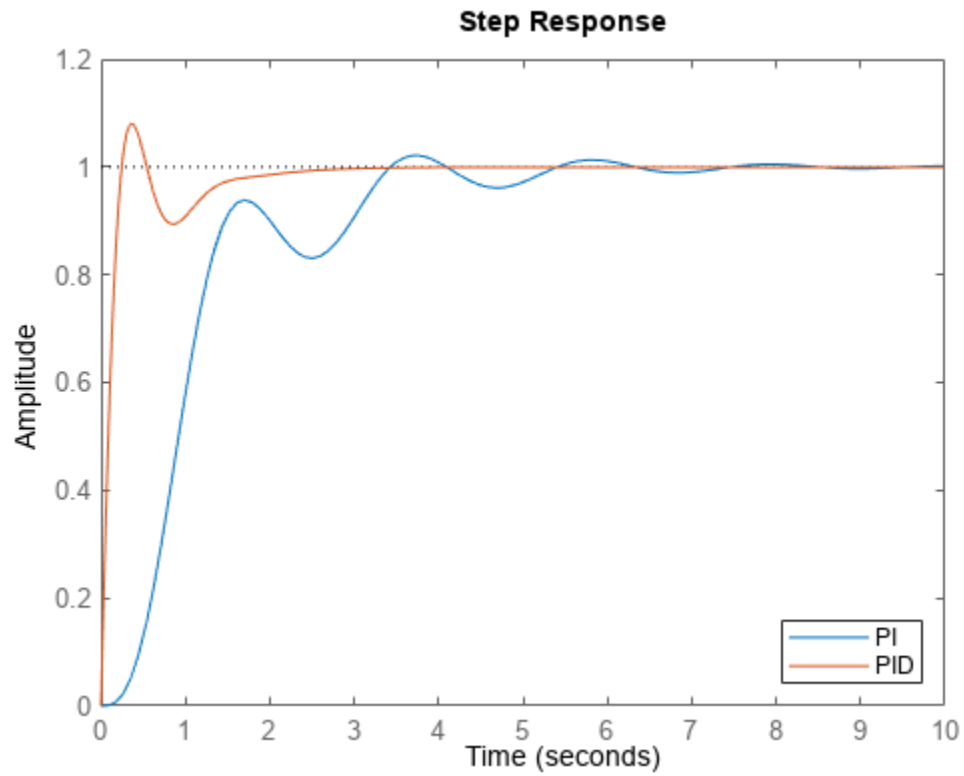

By default, `step` chooses distinct colors for each system that you plot. You can specify colors and line styles using the `LineStyle` input argument.

```
step(sys1, 'r--', sys2, 'b')  
legend('PI', 'PID', 'Location', 'SouthEast')
```

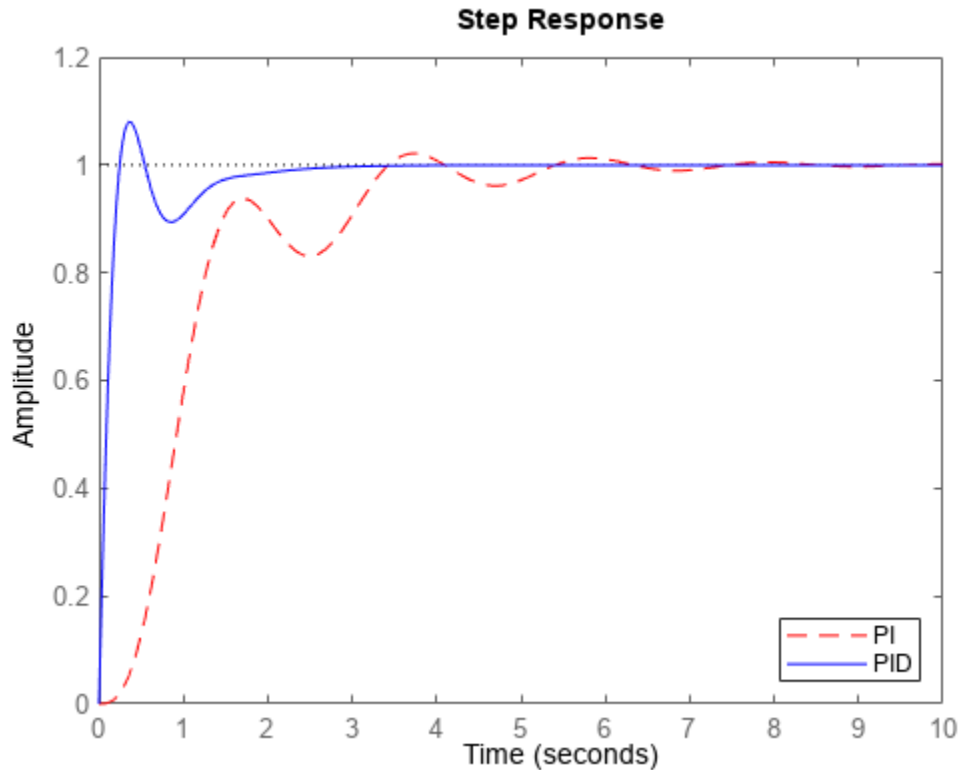
The first LineSpec 'r--' specifies a dashed red line for the response with the PI controller. The second LineSpec 'b' specifies a solid blue line for the response with the PID controller. The legend reflects the specified colors and linestyles. For more plot customization options, use `stepplot`.

Step Response of Systems in a Model Array

The example `Compare Responses of Multiple Systems` shows how to plot responses of several individual systems on a single axis. When you have multiple dynamic systems arranged in a model array, `step` plots all their responses at once.

Create a model array. For this example, use a one-dimensional array of second-order transfer functions having different natural frequencies. First, preallocate memory for the model array. The following command creates a 1-by-5 row of zero-gain SISO transfer functions. The first two dimensions represent the model outputs and inputs. The remaining dimensions are the array dimensions.

```
sys = tf(zeros(1,1,1,5));
```

Populate the array.

```
w0 = 1.5:1:5.5;    % natural frequencies
zeta = 0.5;        % damping constant
for i = 1:length(w0)
```

```

sys(:,:,1,i) = tf(w0(i)^2,[1 2*zeta*w0(i) w0(i)^2]);
end

```

(For more information about model arrays and how to create them, see “Model Arrays”.) Plot the step responses of all models in the array.

```
step(sys)
```

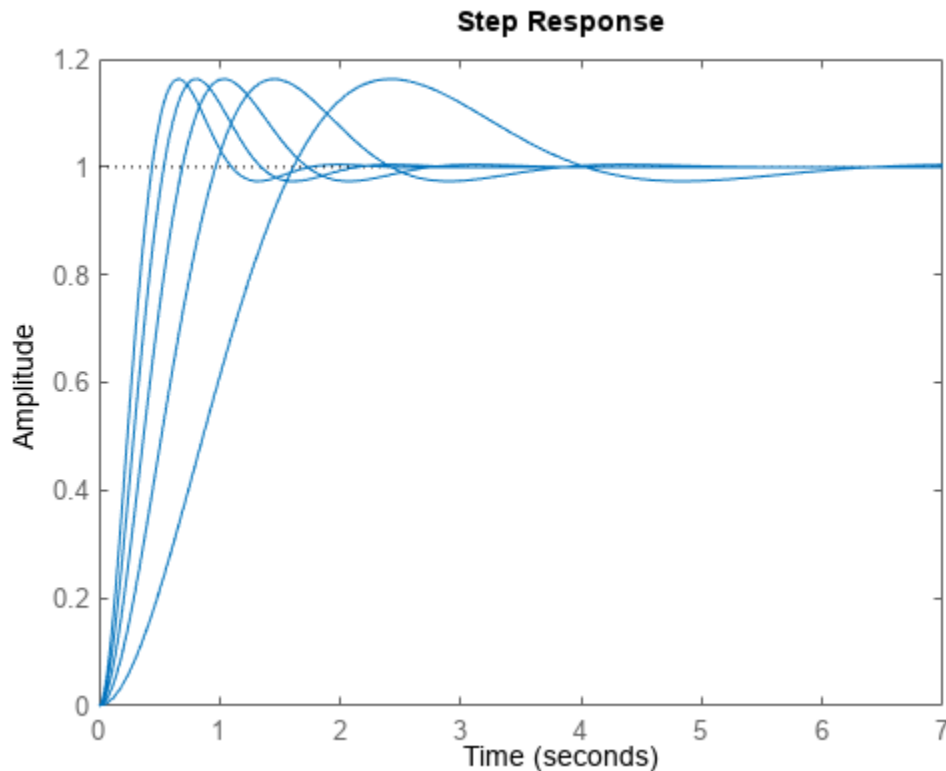

`step` uses the same linestyle for the responses of all entries in the array. One way to distinguish among entries is to use the `SamplingGrid` property of dynamic system models to associate each entry in the array with the corresponding w_0 value.

```
sys.SamplingGrid = struct('frequency',w0);
```

Now, when you plot the responses in a MATLAB figure window, you can click a trace to see which frequency value it corresponds to.

Step Response Data

When you give it an output argument, `step` returns an array of response data. For a SISO system, the response data is returned as a column vector of length equal to the number of time points at which the response is sampled. You can provide the vector `t` of time points, or allow `step` to select time points for you based on system dynamics. For instance, extract the step response of a SISO system at 101 time points between $t = 0$ and $t = 5$ s.

```
sys = tf(4,[1 2 10]);
t = 0:0.05:5;
y = step(sys,t);
size(y)
```

```
ans = 1×2
      101      1
```

For a MIMO system, the response data is returned in an array of dimensions N -by- N_y -by- N_u , where N_y and N_u are the number of outputs and inputs of the dynamic system. For instance, consider the following state-space model, representing a two-input, one-output system.

```
A = [-0.5572, -0.7814;0.7814,0];
B = [1, -1;0, 2];
C = [1.9691,6.4493];
sys = ss(A,B,C,0);
```

Extract the step response of this system at 200 time points between $t = 0$ and $t = 20$ s.

```
t = linspace(0,20,200);
y = step(sys,t);
size(y)
```

```
ans = 1×3
      200      1      2
```

$y(:, i, j)$ is a column vector containing the step response from the j th input to the i th output at the times t . For instance, extract the step response from the second input to the output.

```
y12 = y(:,1,2);
plot(t,y12)
```

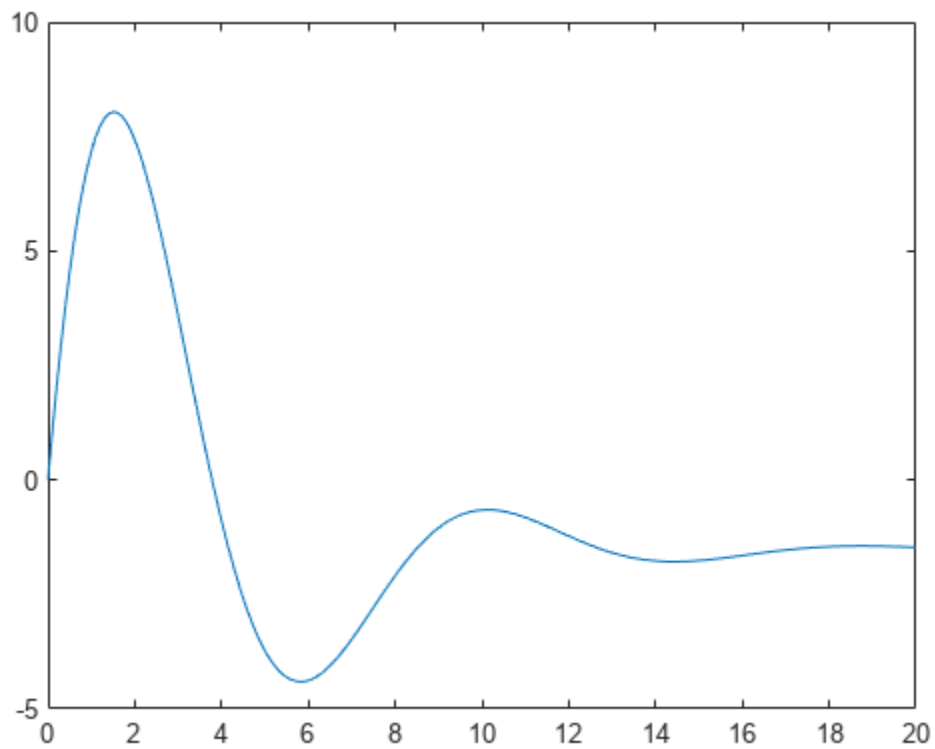

Step Response Plot of Feedback Loop with Delay

Create a feedback loop with delay and plot its step response.

```
s = tf('s');  
G = exp(-s) * (0.8*s^2+s+2)/(s^2+s);  
sys = feedback(ss(G),1);  
step(sys)
```

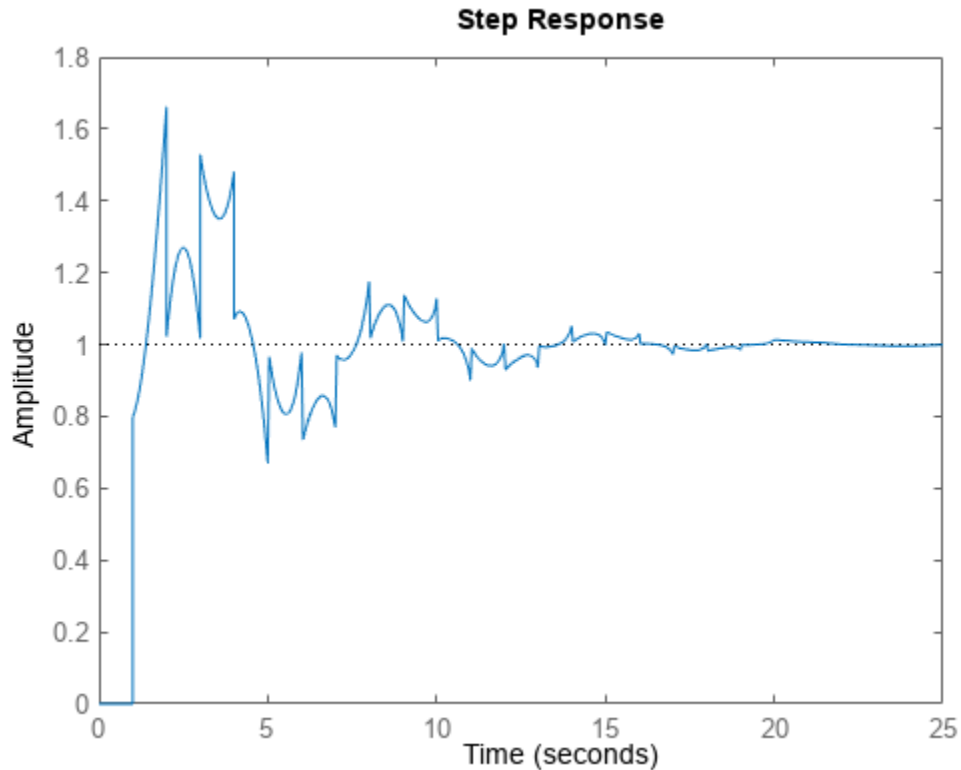

The system step response displayed is chaotic. The step response of systems with internal delays may exhibit odd behavior, such as recurring jumps. Such behavior is a feature of the system and not software anomalies.

Response to Custom Step Input

By default, `step` applies an input signal that changes from 0 to 1 at $t = 0$. To customize the amplitude and offset, use `stepDataOptions`. For instance, compute the response of a SISO state-space model to a signal that changes from 1 to -1 to at $t = 0$.

```
A = [1.6 -0.7;
      1  0];
B = [0.5; 0];
C = [0.1 0.1];
D = 0;
sys = ss(A,B,C,D,0.2);

opt = stepDataOptions;
opt.InputOffset = 1;
opt.StepAmplitude = -2;

step(sys,opt)
```

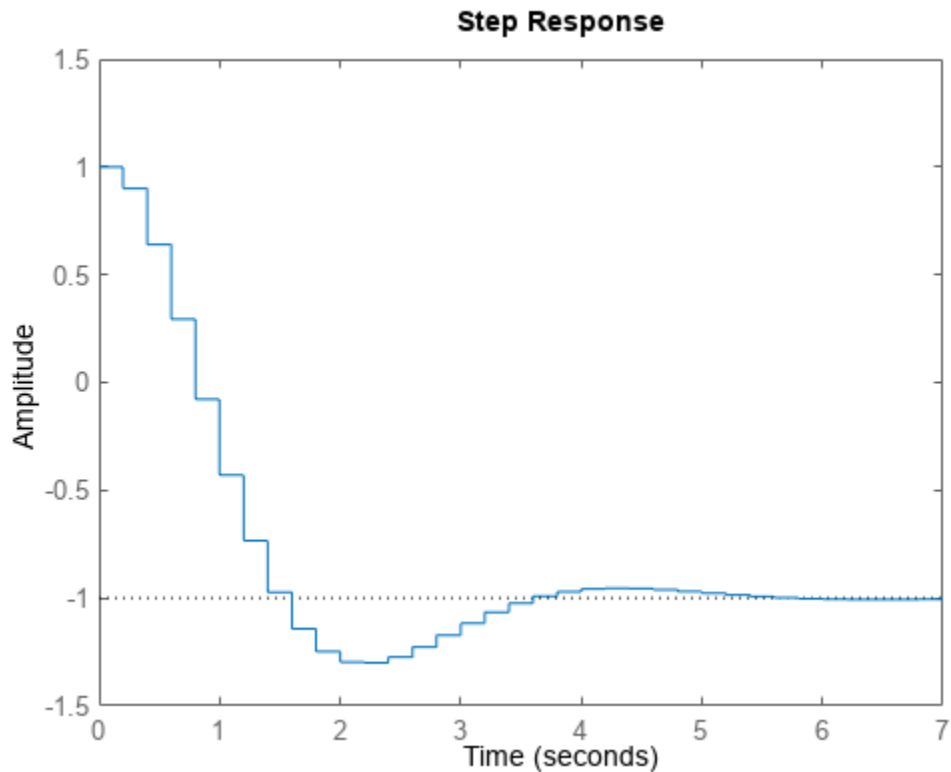

For responses to arbitrary input signals, use `lsim`.

Step Responses of Identified Models with Confidence Regions

Compare the step response of a parametric identified model to a non-parametric (empirical) model. Also view their 3σ confidence regions.

Load the data.

```
load iddata1 z1
```

Estimate a parametric model.

```
sys1 = ssest(z1,4);
```

Estimate a non-parametric model.

```
sys2 = impulseest(z1);
```

Plot the step responses for comparison.

```
t = (0:0.1:10)';
[y1, ~, ~, ysd1] = step(sys1,t);
[y2, ~, ~, ysd2] = step(sys2,t);
plot(t, y1, 'b', t, y1+3*ysd1, 'b:', t, y1-3*ysd1, 'b:')
```

```
hold on
plot(t, y2, 'g', t, y2+3*ysd2, 'g:', t, y2-3*ysd2, 'g:')
```

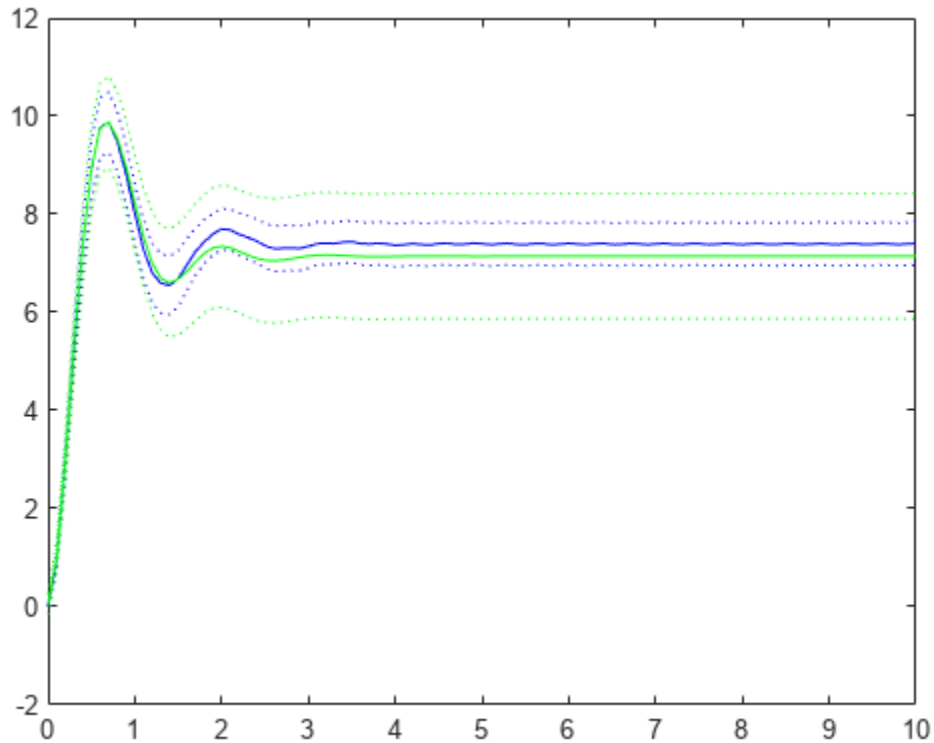

Step Response of Identified Time-Series Model

Compute the step response of an identified time-series model.

A time-series model, also called a signal model, is one without measured input signals. The step plot of this model uses its (unmeasured) noise channel as the input channel to which the step signal is applied.

Load the data.

```
load iddata9;
```

Estimate a time-series model.

```
sys = ar(z9, 4);
```

`sys` is a model of the form $A y(t) = e(t)$, where $e(t)$ represents the noise channel. For computation of step response, $e(t)$ is treated as an input channel, and is named `e@y1`.

Plot the step response.

```
step(sys)
```

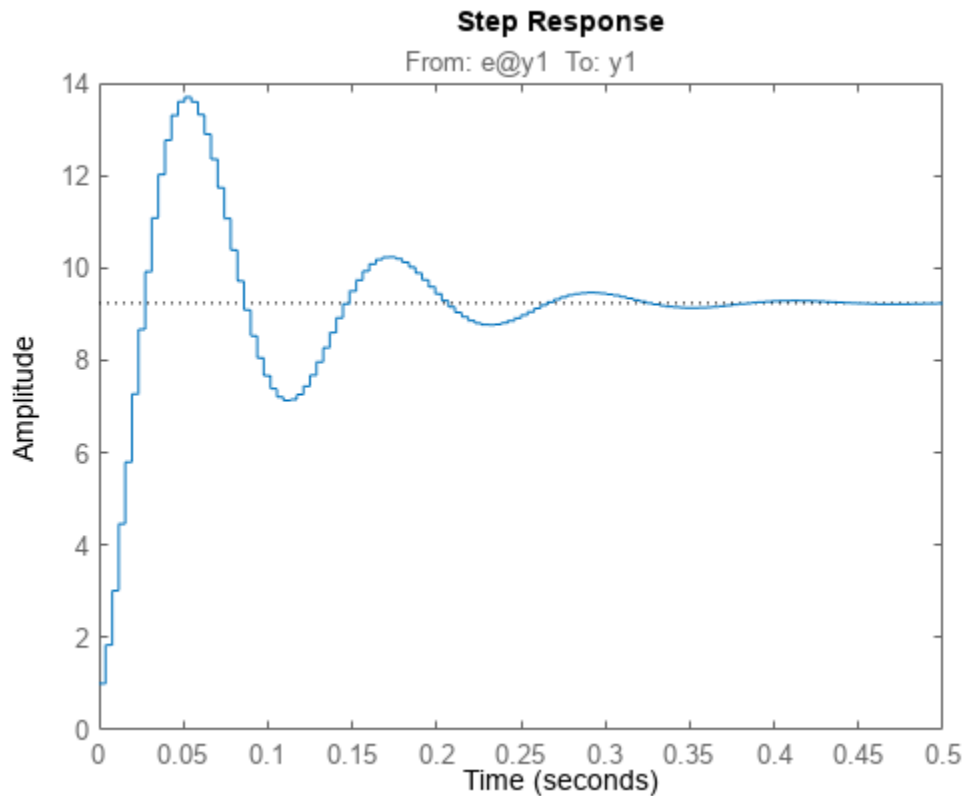

Validate Linearization of Identified Nonlinear ARX Model

Validate the linearization of a nonlinear ARX model by comparing the small amplitude step responses of the linear and nonlinear models.

Load the data.

```
load iddata2 z2;
```

Estimate a nonlinear ARX model.

```
nlsys = nlarx(z2,[4 3 10],idTreePartition,'custom',...
    {'sin(y1(t-2)*u1(t))+y1(t-2)*u1(t)+u1(t).*u1(t-13)',...
    'y1(t-5)*y1(t-5)*y1(t-1)'},'nlr',[1:5, 7 9]);
```

Determine an equilibrium operating point for `nlsys` corresponding to a steady-state input value of 1.

```
u0 = 1;
[X,~,r] = findop(nlsys, 'steady', 1);
y0 = r.SignalLevels.Output;
```

Obtain a linear approximation of `nlsys` at this operating point.

```
sys = linearize(nlsys,u0,X);
```

Validate the usefulness of `sys` by comparing its small-amplitude step response to that of `nlsys`.

The nonlinear system `nlsys` is operating at an equilibrium level dictated by (u_0, y_0) . Introduce a step perturbation of size 0.1 about this steady-state and compute the corresponding response.

```
opt = stepDataOptions;  
opt.InputOffset = u0;  
opt.StepAmplitude = 0.1;  
t = (0:0.1:10)';  
ynl = step(nlsys, t, opt);
```

The linear system `sys` expresses the relationship between the perturbations in input to the corresponding perturbation in output. It is unaware of the nonlinear system's equilibrium values.

Plot the step response of the linear system.

```
opt = stepDataOptions;  
opt.StepAmplitude = 0.1;  
yl = step(sys, t, opt);
```

Add the steady-state offset, y_0 , to the response of the linear system and plot the responses.

```
plot(t, ynl, t, yl+y0)  
legend('Nonlinear', 'Linear with offset')
```

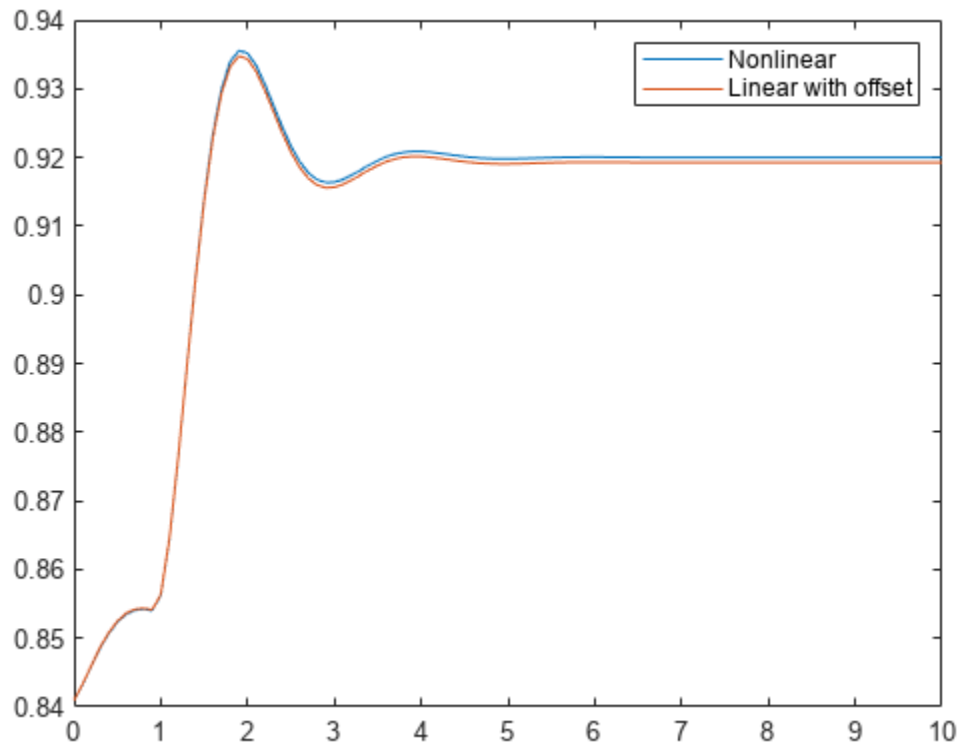

Input Arguments

sys — Dynamic system

dynamic system model | model array

Dynamic system, specified as a SISO or MIMO dynamic system model or array of dynamic system models. Dynamic systems that you can use include:

- Continuous-time or discrete-time numeric LTI models, such as `tf`, `zpk`, or `ss` models.
- Generalized or uncertain LTI models such as `genss` or `uss` models. (Using uncertain models requires Robust Control Toolbox software.)
 - For tunable control design blocks, the function evaluates the model at its current value for both plotting and returning response data.
 - For uncertain control design blocks, the function plots the nominal value and random samples of the model. When you use output arguments, the function returns response data for the nominal model only.
- Sparse state-space models such as `sparss` and `mechss` models.
- Identified LTI models, such as `idtf`, `idss`, or `idproc` models. For such models, the function can also plot confidence intervals and return standard deviations of the frequency response. See “Step Responses of Identified Models with Confidence Regions” on page 2-1300. (Using identified models requires System Identification Toolbox software.)

`step` does not support frequency-response data models such as `frd`, `genfrd`, or `idfrd` models.

If `sys` is an array of models, the function plots the responses of all models in the array on the same axes. See “Step Response of Systems in a Model Array” on page 2-1295.

tFinal — End time for step response

positive scalar

End time for the step response, specified as a positive scalar value. `step` simulates the step response from $t = 0$ to $t = t_{\text{Final}}$.

- For continuous-time systems, the function determines the step size and number of points automatically from system dynamics. Express `tFinal` in the system time units, specified in the `TimeUnit` property of `sys`.
- For discrete-time systems, the function uses the sample time of `sys` as the step size. Express `tFinal` in the system time units, specified in the `TimeUnit` property of `sys`.
- For discrete-time systems with unspecified sample time ($T_s = -1$), `step` interprets `tFinal` as the number of sampling periods to simulate.

t — Time vector

vector

Time vector at which to compute the step response, specified as a vector of positive scalar values. Express `t` in the system time units, specified in the `TimeUnit` property of `sys`.

- For continuous-time models, specify `t` in the form `Ti:dt:Tf`. To obtain the response at each time step, the function uses `dt` as the sample time of a discrete approximation to the continuous system (see “Algorithms” on page 2-1306).

- For discrete-time models, specify t in the form $T_i:T_s:T_f$, where T_s is the sample time of `sys`.

`step` always applies the step input at $t = 0$, regardless of T_i .

LineStyle — Line style, marker, and color

character vector | string

Line style, marker, and color, specified as a string or vector of one, two, or three characters. The characters can appear in any order. You do not need to specify all three characteristics (line style, marker, and color). For example, if you omit the line style and specify the marker, then the plot shows only the marker and no line. For more information about configuring this argument, see the `LineStyle` input argument of the `plot` function.

Example: `'r--'` specifies a red dashed line

Example: `'*b'` specifies blue asterisk markers

Example: `'y'` specifies a yellow line

opts — Input offset and amplitude

`stepDataOptions` options set

Input offset and amplitude of the applied step signal, specified as a `stepDataOptions` option set. By default, `step` applies an input that goes from 0 to 1 at time $t = 0$. Use this input argument to change the initial and final values of the step input. See “Response to Custom Step Input” on page 2-1299 for an example.

Output Arguments

y — Step response data

array

Step response data, returned as an array.

- For SISO systems, y is a column vector of the same length as t (if provided) or `tOut` (if you do not provide t).
- For single-input, multi-output systems, y is a matrix with as many rows as there are time samples and as many columns as there are outputs. Thus, the j th column of y , or $y(:,j)$, contains the step response of from the input to the j th output.
- For MIMO systems, the step responses of each input channel are stacked up along the third dimension of y . The dimensions of y are then N -by- N_y -by- N_u , where:
 - N is the number of time samples.
 - N_y is the number of system outputs.
 - N_u is the number of system inputs.

Thus, $y(:,i,j)$ is a column vector containing the step response from the j th input to the i th output at the times specified in t or `tOut`.

tOut — Times at which step response is computed

vector

Times at which step response is computed, returned as a vector. When you do not provide a specific vector t of times, `step` chooses this time vector based on the system dynamics. The times are expressed in the time units of `sys`.

x — State trajectories

array

State trajectories, returned as an array. When `sys` is a state-space model, `x` contains the evolution of the states of `sys` at each time in `t` or `tOut`. The dimensions of `x` are N -by- N_x -by- N_u , where:

- N is the number of time samples.
- N_x is the number of states.
- N_u is the number of system inputs.

Thus, the evolution of the states in response to a step injected at the k th input is given by the array `x(:, :, k)`. The row vector `x(i, :, k)` contains the state values at the i th time step.

ysd — Standard deviation of step response

array

Standard deviation of the step response of an identified model, returned as an array of the same dimensions as `y`. If `sys` does not contain parameter covariance information, then `ysd` is empty.

Tips

- When you need additional plot customization options, use `stepplot` instead.
- To simulate system responses to arbitrary input signals, use `lsim`.

Algorithms

To obtain samples of continuous-time models without internal delays, `step` converts such models to state-space models and discretizes them using a zero-order hold on the inputs. `step` chooses the sampling time for this discretization automatically based on the system dynamics, except when you supply the input time vector `t` in the form `t = 0:dt:Tf`. In that case, `step` uses `dt` as the sampling time. The resulting simulation time steps `tOut` are equisampled with spacing `dt`.

For systems with internal delays, Control System Toolbox software uses variable step solvers. As a result, the time steps `tOut` are not equisampled.

Version History**Introduced before R2006a****References**

- [1] L.F. Shampine and P. Gahinet, "Delay-differential-algebraic equations in control theory," *Applied Numerical Mathematics*, Vol. 56, Issues 3-4, pp. 574-588.

See Also**Functions**

impulse | stepDataOptions | initial | lsim | stepplot

Apps**Linear System Analyzer**

External Websites

Transfer Function Analysis of Dynamic Systems (MathWorks Teaching Resources)

stepDataOptions

Options for the step command

Syntax

```
opt = stepDataOptions
opt = stepDataOptions(Name,Value)
```

Description

`opt = stepDataOptions` creates the default options for `step`.

`opt = stepDataOptions(Name,Value)` creates an options set with the options specified by one or more `Name,Value` pair arguments.

Examples

Specify Input Offset and Step Amplitude Level for Step Response

Create a transfer function model.

```
sys = tf(1,[1,1]);
```

Create an option set for `step` to specify input offset and step amplitude level.

```
opt = stepDataOptions('InputOffset',-1,'StepAmplitude',2);
```

Calculate the step response using the specified options.

```
[y,t] = step(sys,opt);
```

Input Arguments

Name-Value Pair Arguments

Specify optional pairs of arguments as `Name1=Value1, ..., NameN=ValueN`, where `Name` is the argument name and `Value` is the corresponding value. Name-value arguments must appear after other arguments, but the order of the pairs does not matter.

Before R2021a, use commas to separate each name and value, and enclose Name in quotes.

Example: `..., 'InputOffset', 2`

InputOffset — Input signal offset level

0 (default) | scalar

Input signal offset level, specified as the comma-separated pair consisting of `'InputOffset'` and a scalar, for all time $t < 0$, as shown in the following figure.

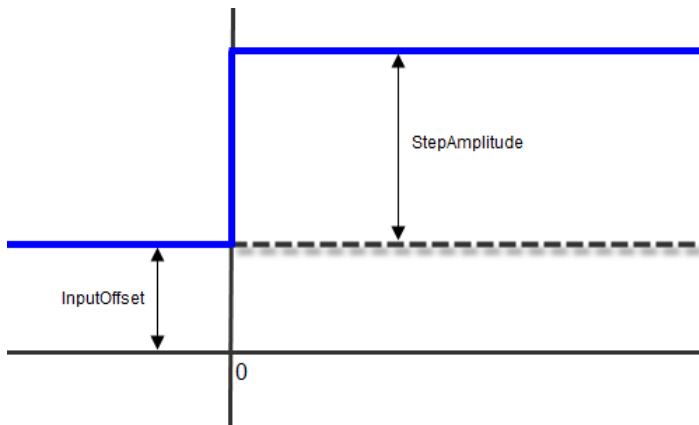

StepAmplitude — Change of input signal offset

1 (default) | scalar

Change of input signal offset level, specified as the comma-separated pair consisting of 'StepAmplitude' and a scalar, which occurs at time $t = 0$, as shown in the previous figure.

Output Arguments

opt — Options for the step command

step options set

Options for the step command, returned as a step options set.

Version History

Introduced in R2012a

See Also

step

stepinfo

Rise time, settling time, and other step-response characteristics

Syntax

```
S = stepinfo(sys)
S = stepinfo(y,t)
S = stepinfo(y,t,yfinal)
S = stepinfo(y,t,yfinal,yinit)

S = stepinfo(____, 'SettlingTimeThreshold', ST)
S = stepinfo(____, 'RiseTimeLimits', RT)
```

Description

`stepinfo` lets you compute step-response characteristics for a dynamic system model or for an array of step-response data. For a step response $y(t)$, `stepinfo` computes characteristics relative to y_{init} and y_{final} , where y_{init} is the initial offset, that is, the value before the step is applied, and y_{final} is the steady-state value of the response. These values depend on the syntax you use.

- For a dynamic system model `sys`, `stepinfo` uses $y_{init} = 0$ and $y_{final} =$ steady-state value.
- For an array of step-response data `[y,t]`, `stepinfo` uses $y_{init} = 0$ and $y_{final} =$ last sample value of `y`, unless you explicitly specify these values.

For more information on how `stepinfo` computes the step-response characteristics, see “Algorithms” on page 2-1323.

The following figure illustrates some of the characteristics `stepinfo` computes for a step response. For this response, assume that $y(t) = 0$ for $t < 0$, so $y_{init} = 0$.

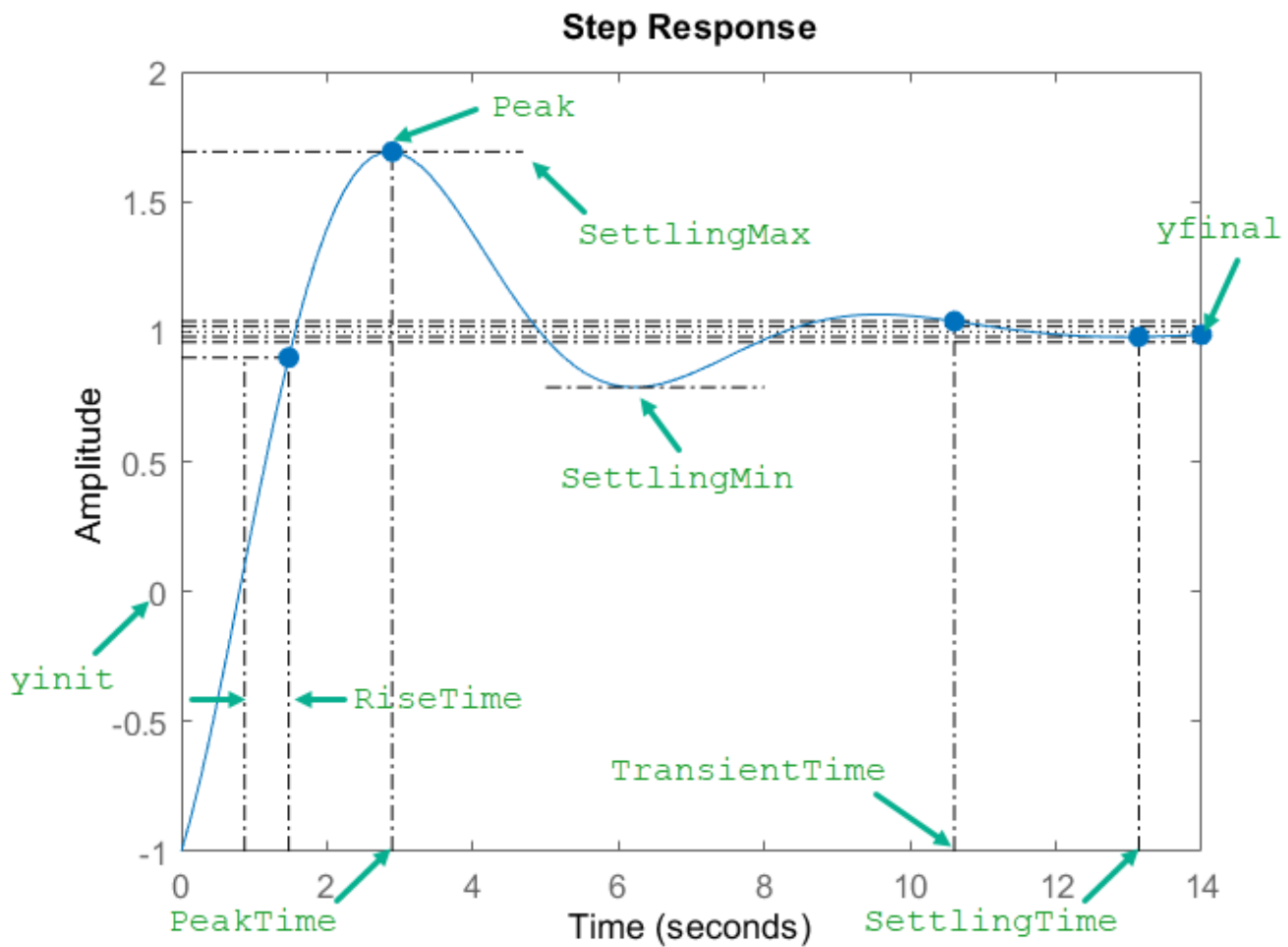

`S = stepinfo(sys)` computes the step-response characteristics for a dynamic system model `sys`. This syntax uses $y_{init} = 0$ and y_{final} = steady-state value for computing the characteristics that depend on these values.

`S = stepinfo(y,t)` computes step-response characteristics from an array of step-response data `y` and a corresponding time vector `t`. For SISO system responses, `y` is a vector with the same number of entries as `t`. For MIMO response data, `y` is an array containing the responses of each I/O channel. This syntax uses $y_{init} = 0$ and the last value in `y` (or the last value in each channel's corresponding response data) as y_{final} .

`S = stepinfo(y,t,yfinal)` computes step-response characteristics relative to the steady-state value `yfinal`. This syntax is useful when you know that the expected steady-state system response differs from the last value in `y` for reasons such as measurement noise. This syntax uses $y_{init} = 0$.

For SISO responses, `t` and `y` are vectors with the same length `NS`. For systems with `NU` inputs and `NY` outputs, you can specify `y` as an `NS`-by-`NY`-by-`NU` array (see `step`) and `yfinal` as an `NY`-by-`NU` array. `stepinfo` then returns a `NY`-by-`NU` structure array `S` of response characteristics corresponding to each I/O pair.

`S = stepinfo(y,t,yfinal,yinit)` computes step-response characteristics relative to the response initial value `yinit`. This syntax is useful when your `y` data has an initial offset; that is, `y` is nonzero before the step occurs.

For SISO responses, `t` and `y` are vectors with the same length `NS`. For systems with `NU` inputs and `NY` outputs, you can specify `y` as an `NS`-by-`NY`-by-`NU` array and `yinit` as an `NY`-by-`NU` array. `stepinfo` then returns a `NY`-by-`NU` structure array `S` of response characteristics corresponding to each I/O pair.

`S = stepinfo(____, 'SettlingTimeThreshold', ST)` lets you specify the threshold `ST` used in the definition of settling and transient times. The default value is `ST = 0.02` (2%). You can use this syntax with any of the previous input-argument combinations.

`S = stepinfo(____, 'RiseTimeLimits', RT)` lets you specify the lower and upper thresholds used in the definition of rise time. By default, the rise time is the time the response takes to rise from 10% to 90% of the way from the initial value to the steady-state value (`RT = [0.1 0.9]`). The upper threshold `RT(2)` is also used to calculate `SettlingMin` and `SettlingMax`. These values are the minimum and maximum values of the response occurring after the response reaches the upper threshold. You can use this syntax with any of the previous input-argument combinations.

Examples

Step-Response Characteristics of Dynamic System

Compute step-response characteristics, such as rise time, settling time, and overshoot, for a dynamic system model. For this example, use a continuous-time transfer function:

$$\text{sys} = \frac{s^2 + 5s + 5}{s^4 + 1.65s^3 + 5s^2 + 6.5s + 2}$$

Create the transfer function and examine its step response.

```
sys = tf([1 5 5],[1 1.65 5 6.5 2]);  
step(sys)
```

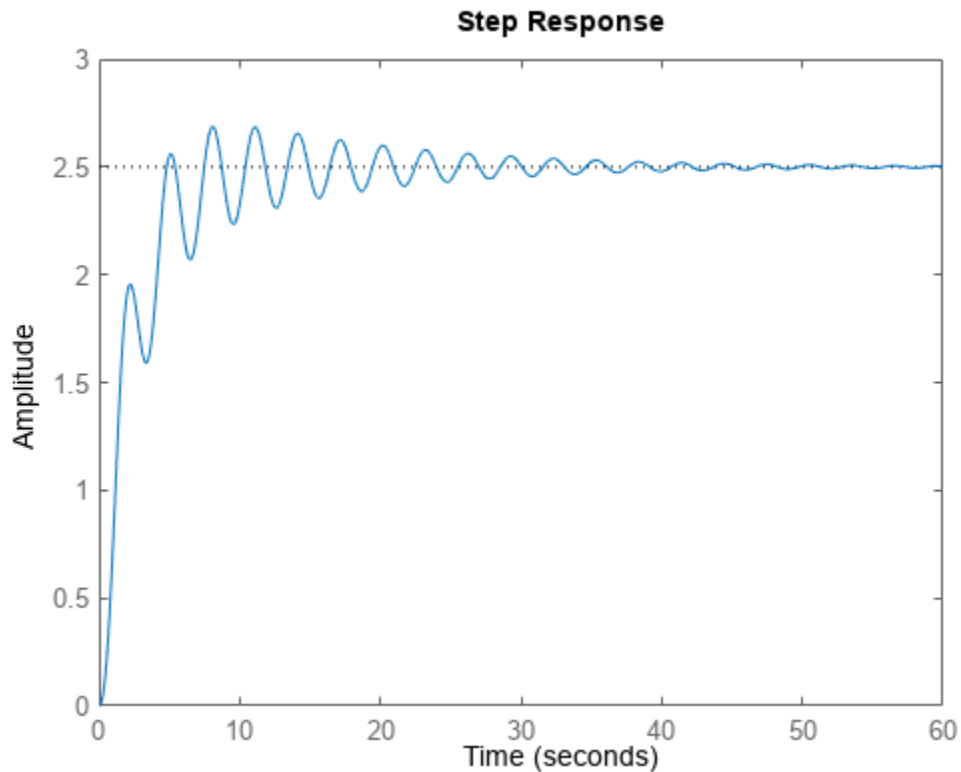

The plot shows that the response rises in a few seconds, and then rings down to a steady-state value of about 2.5. Compute the characteristics of this response using `stepinfo`.

```
S = stepinfo(sys)
```

```
S = struct with fields:
    RiseTime: 3.8456
    TransientTime: 27.9762
    SettlingTime: 27.9762
    SettlingMin: 2.0689
    SettlingMax: 2.6873
    Overshoot: 7.4915
    Undershoot: 0
    Peak: 2.6873
    PeakTime: 8.0530
```

Here, the function uses $y_{\text{init}}=0$ to compute characteristics for the dynamic system model `sys`.

By default, the settling time is the time it takes for the error to stay below 2% of $|y_{\text{init}} - y_{\text{final}}|$. The result `S.SettlingTime` shows that for `sys`, this condition occurs after about 28 seconds. The default definition of rise time is the time it takes for the response to go from 10% to 90% of the way from $y_{\text{init}}=0$ to y_{final} . `S.RiseTime` shows that for `sys`, this rise occurs in less than 4 seconds. The maximum overshoot is returned in `S.Overshoot`. For this system, the peak value `S.Peak`, which occurs at the time `S.PeakTime`, overshoots by about 7.5% of the steady-state value.

Step-Response Characteristics of MIMO System

For a MIMO system, `stepinfo` returns a structure array in which each entry contains the response characteristics of the corresponding I/O channel of the system. For this example, use a two-output, two-input discrete-time system. Compute the step-response characteristics.

```
A = [0.68 -0.34; 0.34 0.68];  
B = [0.18 -0.05; 0.04 0.11];  
C = [0 -1.53; -1.12 -1.10];  
D = [0 0; 0.06 -0.37];  
sys = ss(A,B,C,D,0.2);
```

```
S = stepinfo(sys)
```

```
S=2x2 struct array with fields:
```

```
RiseTime  
TransientTime  
SettlingTime  
SettlingMin  
SettlingMax  
Overshoot  
Undershoot  
Peak  
PeakTime
```

Access the response characteristics for a particular I/O channel by indexing into `S`. For instance, examine the response characteristics for the response from the first input to the second output of `sys`, corresponding to `S(2,1)`.

```
S(2,1)
```

```
ans = struct with fields:  
    RiseTime: 0.4000  
    TransientTime: 2.8000  
    SettlingTime: 3  
    SettlingMin: -0.6724  
    SettlingMax: -0.5188  
    Overshoot: 24.6476  
    Undershoot: 11.1224  
    Peak: 0.6724  
    PeakTime: 1
```

To access a particular value, use dot notation. For instance, extract the rise time of the (2,1) channel.

```
rt21 = S(2,1).RiseTime
```

```
rt21 = 0.4000
```

Specify Percentage for Settling Time or Rise Time

You can use `SettlingTimeThreshold` and `RiseTimeThreshold` to change the default percentage for settling and rise times, respectively, as described in the “Algorithms” on page 2-1323 section. For this example, use the system given by:

$$\text{sys} = \frac{s^2 + 5s + 5}{s^4 + 1.65s^3 + 6.5s + 2}$$

Create the transfer function.

```
sys = tf([1 5 5],[1 1.65 5 6.5 2]);
```

Compute the time it takes for the error in the response of `sys` to stay below 0.5% of the gap $|y_{\text{final}} - y_{\text{init}}|$. To do so, set `SettlingTimeThreshold` to 0.5%, or 0.005.

```
S1 = stepinfo(sys, 'SettlingTimeThreshold', 0.005);
st1 = S1.SettlingTime
```

```
st1 = 46.1325
```

Compute the time it takes the response of `sys` to rise from 5% to 95% of the way from y_{init} to y_{final} . To do so, set `RiseTimeThreshold` to a vector containing those bounds.

```
S2 = stepinfo(sys, 'RiseTimeThreshold', [0.05 0.95]);
rt2 = S2.RiseTime
```

```
rt2 = 4.1690
```

You can define percentages for both settling time and rise time in the same computation.

```
S3 = stepinfo(sys, 'SettlingTimeThreshold', 0.005, 'RiseTimeThreshold', [0.05 0.95])
```

```
S3 = struct with fields:
    RiseTime: 4.1690
    TransientTime: 46.1325
    SettlingTime: 46.1325
    SettlingMin: 2.0689
    SettlingMax: 2.6873
    Overshoot: 7.4915
    Undershoot: 0
    Peak: 2.6873
    PeakTime: 8.0530
```

Step-Response Characteristics from Response Data

You can extract step-response characteristics from step-response data even if you do not have a model of your system. For instance, suppose you have measured the response of your system to a step input and saved the resulting response data in a vector `y` of response values at the times stored in another vector `t`. Load the response data and examine it.

```
load StepInfoData t y
plot(t,y)
```

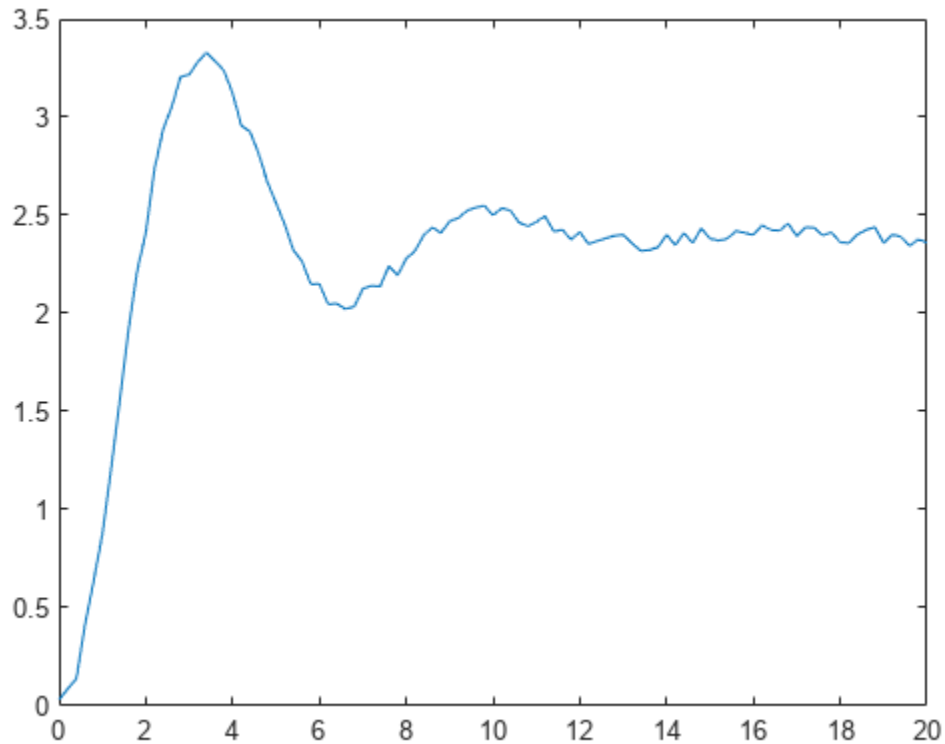

Compute step-response characteristics from this response data using `stepinfo`. If you do not specify the steady-state response value `yfinal`, then `stepinfo` assumes that the last value in the response vector `y` is the steady-state response. Because the data has some noise, the last value in `y` is likely not the true steady-state response value. When you know what the steady-state value should be, you can provide it to `stepinfo`. For this example, suppose that the steady-state response is 2.4.

```
S1 = stepinfo(y,t,2.4)
```

```
S1 = struct with fields:
    RiseTime: 1.2897
    TransientTime: 19.6478
    SettlingTime: 19.6439
    SettlingMin: 2.0219
    SettlingMax: 3.3302
    Overshoot: 38.7575
    Undershoot: 0
    Peak: 3.3302
    PeakTime: 3.4000
```

Because of the noise in the data, the default definition of the settling time is too stringent, resulting in an arbitrary value of almost 20 seconds. To allow for the noise, increase the settling-time threshold from the default 2% to 5%.

```
S2 = stepinfo(y,t,2.4,'SettlingTimeThreshold',0.05)
```

```
S2 = struct with fields:
    RiseTime: 1.2897
```

```

TransientTime: 10.4201
SettlingTime: 10.4149
SettlingMin: 2.0219
SettlingMax: 3.3302
Overshoot: 38.7575
Undershoot: 0
Peak: 3.3302
PeakTime: 3.4000

```

Difference Between Transient Time and Settling Time for Step Responses

Settling time and transient time are equal when the peak error e_{\max} is equal to the gap $|y_{\text{final}} - y_{\text{init}}|$ (see “Algorithms” on page 2-1323), which is the case for models with no undershoot or feedthrough and with less than 100% overshoot. They tend to differ for models with feedthrough, zeros at the origin, unstable zeros (undershoot), or large overshoot.

Consider the following models.

```

s = tf('s');
sys1 = 1+tf(1,[1 1]);           % feedthrough
sys2 = tf([1 0],[1 1]);        % zero at the origin
sys3 = tf([-3 1],[1 2 1]);     % non-minimum phase with undershoot
sys4 = (s/0.5 + 1)/(s^2 + 0.2*s + 1); % large overshoot

step(sys1,sys2,sys3,sys4)
grid on
legend('Feedthrough','Zero at origin','Non-minimum phase with undershoot','Large overshoot')

```

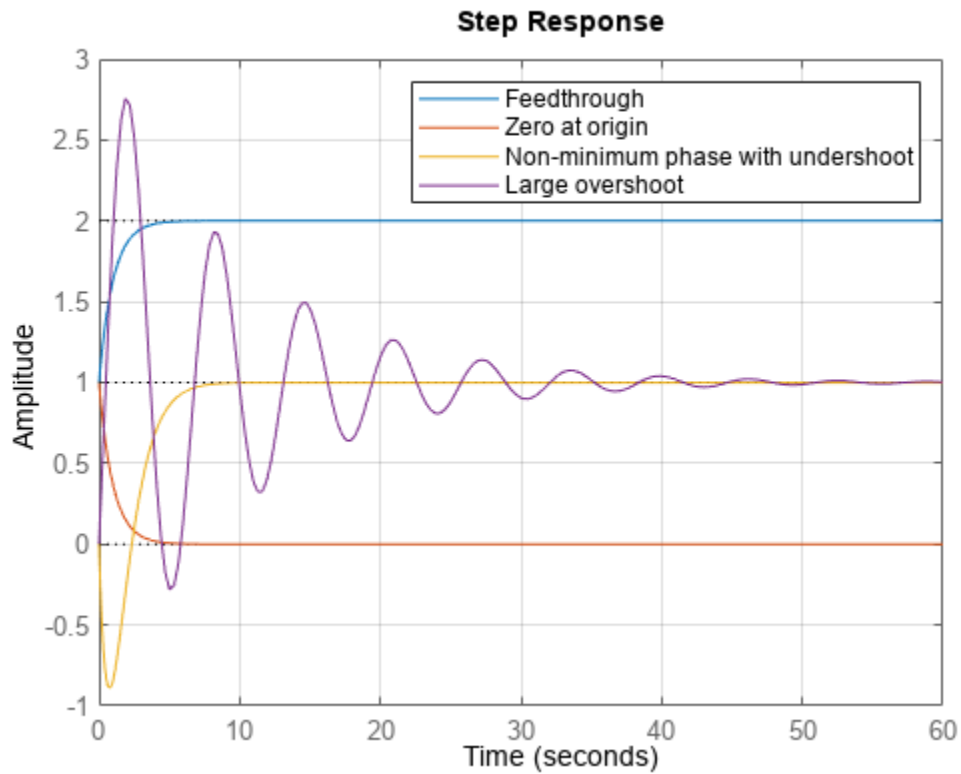

Compute the step-response characteristics.

```
S1 = stepinfo(sys1)
```

```
S1 = struct with fields:
    RiseTime: 1.6095
    TransientTime: 3.9121
    SettlingTime: 3.2190
    SettlingMin: 1.8005
    SettlingMax: 2.0000
    Overshoot: 0
    Undershoot: 0
    Peak: 2.0000
    PeakTime: 10.5458
```

```
S2 = stepinfo(sys2)
```

```
S2 = struct with fields:
    RiseTime: 0
    TransientTime: 3.9121
    SettlingTime: NaN
    SettlingMin: 2.6303e-05
    SettlingMax: 1
    Overshoot: Inf
    Undershoot: 0
    Peak: 1
```



```
PeakTime: 0
```

```
S3 = stepinfo(sys3)
```

```
S3 = struct with fields:
    RiseTime: 2.9198
    TransientTime: 6.5839
    SettlingTime: 7.3229
    SettlingMin: 0.9004
    SettlingMax: 0.9991
    Overshoot: 0
    Undershoot: 88.9466
    Peak: 0.9991
    PeakTime: 10.7900
```

```
S4 = stepinfo(sys4)
```

```
S4 = struct with fields:
    RiseTime: 0.3896
    TransientTime: 40.3317
    SettlingTime: 46.5052
    SettlingMin: -0.2796
    SettlingMax: 2.7571
    Overshoot: 175.7137
    Undershoot: 27.9629
    Peak: 2.7571
    PeakTime: 1.8850
```

Examine the plots and characteristics. For these models, the settling time and transient time differ because the peak error exceeds the gap between the initial and the final value. For models such as `sys2`, the settling time is returned as `NaN` because the steady-state value is zero.

Step Response Characteristics for Data with Initial Offset

In this example, you compute the step-response characteristics from step-response data that has an initial offset. This means that the value of the response data is nonzero before the step occurs.

Load the step-response data and examine the plot.

```
load stepDataOffset.mat
plot(stepOffset.Time, stepOffset.Data)
```

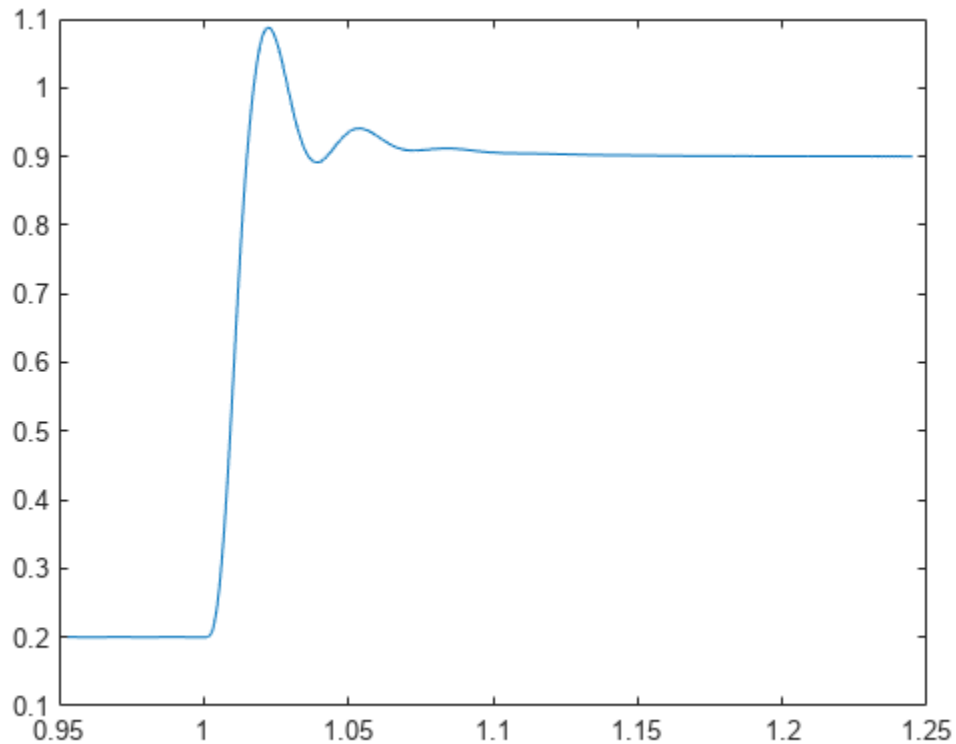

If you do not specify `yfinal` and `yinit`, then `stepinfo` assumes that `yfinal` is the last value in the response vector `y` and `yinit` is zero. When you know what the steady-state and initial values are, you can provide them to `stepinfo`. Here, the steady state of the response `yfinal` is 0.9 and the initial offset `yinit` is 0.2.

Compute step-response characteristics from this response data.

```
S = stepinfo(stepOffset.Data,stepOffset.Time,0.9,0.2)
```

```
S = struct with fields:
    RiseTime: 0.0084
    TransientTime: 1.0662
    SettlingTime: 1.0662
    SettlingMin: 0.8461
    SettlingMax: 1.0878
    Overshoot: 26.8259
    Undershoot: 0.0429
    Peak: 0.8878
    PeakTime: 1.0225
```

Here, the peak value of this response is 0.8878 because `stepinfo` measures the maximum deviation from `yinit`.

Input Arguments

sys — Dynamic system

dynamic system model

Dynamic system, specified as a SISO or MIMO dynamic system model. Dynamic systems that you can use include:

- Continuous-time or discrete-time numeric LTI models, such as `tf`, `zpk`, or `ss` models.
- Generalized or uncertain LTI models such as `genss` or `uss` models. (Using uncertain models requires Robust Control Toolbox software.) For generalized models, `stepinfo` computes the step-response characteristics using the current value of tunable blocks and the nominal value of uncertain blocks.
- Identified LTI models, such as `idtf`, `idss`, or `idproc` models. (Using identified models requires System Identification Toolbox software.)

y — Step-response data

vector | array

Step-response data, specified as one of the following:

- For SISO response data, a vector of length N_s , where N_s is the number of samples in the response data
- For MIMO response data, an N_s -by- N_y -by- N_u array, where N_y is the number of system outputs and N_u is the number of system inputs

t — Time vector

vector

Time vector corresponding to the response data in `y`, specified as a vector of length N_s .

yfinal — Steady-state value

scalar | array

Steady-state value, specified as a scalar or an array.

- For SISO response data, specify a scalar value.
- For MIMO response data, specify an N_y -by- N_u array, where each entry provides the steady-state response value for the corresponding system channel.

If you do not provide `yfinal`, then `stepinfo` uses the last value in the corresponding channel of `y` as the steady-state response value.

This argument is only supported when you provide step-response data as an input. For a dynamic system model `sys` as an input, `stepinfo` uses y_{final} = steady-state value to compute the characteristics that depend on this value.

yinit — Initial value

scalar | array

Value of `y` before the step occurs, specified as a scalar or an array.

- For SISO response data, specify a scalar value.

- For MIMO response data, specify an N_y -by- N_u array, where each entry provides the response initial value for the corresponding system channel.

If you do not provide `yinit`, then `stepinfo` uses zero as the response initial value.

The response $y(0)$ at $t = 0$ is equal to y_{init} for systems without feedthrough. However, the two quantities differ in the presence of feedthrough because of the discontinuity at $t = 0$.

For example, the following figure shows the step response of a system with feedthrough `sys = tf([-1 0.2 1],[1 0.7 1])`.

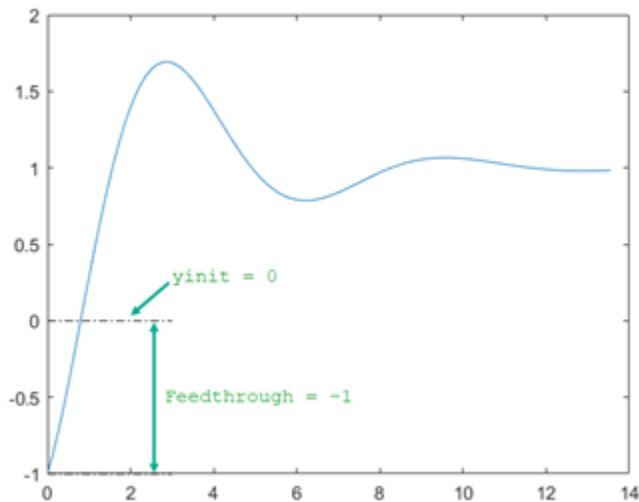

Here, y_{init} is zero and the feedthrough value is -1.

This argument is only supported when you provide step-response data as an input. For a dynamic system model `sys` as an input, `stepinfo` uses $y_{init} = 0$ to compute the characteristics that depend on this value.

ST — Settling time threshold

0.02 (default) | scalar between 0 and 1

Threshold for defining settling and transient times, specified as a scalar value between 0 and 1. To change the default settling and transient time definitions (see “Algorithms” on page 2-1323), set ST to a different value. For instance, to measure when the error falls below 5%, set ST to 0.05.

RT — Rise time thresholds

[0.1 0.9] (default) | 2-element row vector

Threshold for defining rise time, specified as a 2-element row vector of nondescending values between 0 and 1. To change the default rise time definition (see “Algorithms” on page 2-1323), set RT to a different value. For instance, to define the rise time as the time it takes for the response to rise from 5% to 95% from the initial value to the steady-state value, set RT to [0.05 0.95].

Output Arguments

S — Step-response characteristics

structure

Step-response characteristics, returned as a structure containing the fields:

- RiseTime
- TransientTime
- SettlingTime
- SettlingMin
- SettlingMax
- Overshoot
- Undershoot
- Peak
- PeakTime

For more information on how `stepinfo` defines these characteristics, see “Algorithms” on page 2-1323.

For MIMO models or responses data, `S` is a structure array in which each entry contains the step-response characteristics of the corresponding I/O channel. For instance, if you provide a 3-input, 3-output model or an array of response data, then `S(2,3)` contains the characteristics of the response from the third input to the second output. For an example, see “Step-Response Characteristics of MIMO System” on page 2-1314.

If `sys` is unstable, then all step-response characteristics are NaN, except for `Peak` and `PeakTime`, which are Inf.

Algorithms

For a step response $y(t)$, `stepinfo` computes characteristics relative to y_{init} and y_{final} . For a dynamic system model `sys`, `stepinfo` uses $y_{init} = 0$ and $y_{final} = \text{steady-state value}$.

This table shows how `stepinfo` computes each characteristic.

Step-Response Characteristic	Description
RiseTime	Time it takes for the response to rise from 10% to 90% of the way from y_{init} to y_{final}
TransientTime	The first time T such that the error $ y(t) - y_{final} \leq \text{SettlingTimeThreshold} \times e_{max}$ for $t \geq T$, where e_{max} is the maximum error $ y(t) - y_{final} $ for $t \geq 0$. By default, $\text{SettlingTimeThreshold} = 0.02$ (2% of the peak error). Transient time measures how quickly the transient dynamics die off.

Step-Response Characteristic	Description
SettlingTime	The first time T such that the error $ y(t) - y_{final} \leq \text{SettlingTimeThreshold} \times y_{final} - y_{init} $ for $t \geq T$. By default, <code>SettlingTime</code> measures the time it takes for the error to stay below 2% of $ y_{final} - y_{init} $.
SettlingMin	Minimum value of $y(t)$ once the response has risen
SettlingMax	Maximum value of $y(t)$ once the response has risen
Overshoot	Percentage overshoot. Relative to the normalized response $y_{norm}(t) = (y(t) - y_{init}) / (y_{final} - y_{init})$, the overshoot is the larger of zero and $100 \times \max(y_{norm}(t) - 1)$.
Undershoot	Percentage undershoot. Relative to the normalized response $y_{norm}(t)$, the undershoot is the smaller of zero and $-100 \times \max(y_{norm}(t) - 1)$.
Peak	Peak value of $ y(t) - y_{init} $
PeakTime	Time at which the peak value occurs

Version History

Introduced in R2006a

Response characteristics computation changes

Behavior changed in R2021b

The computation method of some response characteristics has changed. Additionally, the settling time calculation is now based on how quickly the response stays below a specified threshold of the gap between the initial and the final value.

The following table summarizes the changes to the fields of the structure returned by `stepinfo`.

Before R2021b	R2021b
RiseTime — Time it takes for the response to rise from 10% to 90% of the way from $y(1)$ to y_{final} .	RiseTime — Time it takes to go from 10% to 90% of the way from y_{init} to y_{final} .
SettlingTime — The first time T such that the error $ y(t) - y_{final} \leq \text{SettlingTimeThreshold} \times e_{max}$ for $t \geq T$, where e_{max} is the maximum error $ y(t) - y_{final} $ for $t \geq 0$. By default, $\text{SettlingTimeThreshold} = 0.02$ (2% of the peak error). <code>SettlingTime</code> measures the time for the error to fall below 2% of the peak value of the error.	SettlingTime — The first time T such that the error $ y(t) - y_{final} \leq \text{SettlingTimeThreshold} \times y_{final} - y_{init} $ for $t \geq T$. By default, <code>SettlingTime</code> measures the time it takes for the error to stay below 2% of $ y_{final} - y_{init} $.
Peak — Peak absolute value of $y(t)$.	Peak — Peak absolute value of $y(t) - y_{init}$.

Additionally, the output structure `S` now contains a `TransientTime` field. This characteristic contains the peak-error-based settling time calculation used in releases before R2021b. `TransientTime` measures how quickly the transient dynamics die off.

These changes also apply to the characteristics of `step`, `impulse`, and `initial` plots. Additionally:

- For `step` plots, y_{init} is always assumed to be zero and y_{final} is the steady-state value.
- For the step response, transient time and settling time tend to differ for models with feedthrough, zeros at the origin, unstable zeros (undershoot), or large overshoot. They match for models with no undershoot or feedthrough, and with less than 100% overshoot. For an example, see “Difference Between Transient Time and Settling Time for Step Responses” on page 2-1317.
- For the step response of models with feedthrough, the new `RiseTime` value can differ because $y(1)$ is nonzero whereas y_{init} is zero by default. Before R2021b, the rise time computed was the time it takes to go from 10% to 90% of the way from $y(1)$ to y_{final} , instead of y_{init} to y_{final} now.

See Also

`step` | `lsiminfo`

stepplot

Plot step response with additional plot customization options

Syntax

```
h = stepplot(sys)
h = stepplot(sys1,sys2,...,sysN)
h = stepplot(sys1,LineStyle1,...,sysN,LineStyleN)
h = stepplot( ___,tFinal)
h = stepplot( ___,t)
h = stepplot(AX, ___)
h = stepplot( ___,plotoptions)
h = stepplot( ___,dataoptions)
```

Description

`stepplot` lets you plot dynamic system step responses with a broader range of plot customization options than `step`. You can use `stepplot` to obtain the plot handle and use it to customize the plot, such as modify the axes labels, limits and units. You can also use `stepplot` to draw a step response plot on an existing set of axes represented by an axes handle. To customize an existing step plot using the plot handle:

- 1 Obtain the plot handle
- 2 Use `getoptions` to obtain the option set
- 3 Update the plot using `setoptions` to modify the required options

For more information, see “Customizing Response Plots from the Command Line”. To create step plots with default options or to extract step response data, use `step`.

`h = stepplot(sys)` plots the step response of the dynamic system model `sys` and returns the plot handle `h` to the plot. You can use this handle `h` to customize the plot with the `getoptions` and `setoptions` commands.

`h = stepplot(sys1,sys2,...,sysN)` plots the step response of multiple dynamic systems `sys1,sys2,...,sysN` on the same plot. All systems must have the same number of inputs and outputs to use this syntax.

`h = stepplot(sys1,LineStyle1,...,sysN,LineStyleN)` sets the line style, marker type, and color for the step response of each system. All systems must have the same number of inputs and outputs to use this syntax.

`h = stepplot(___,tFinal)` simulates the step response from $t = 0$ to the final time $t = tFinal$. Specify `tFinal` in the system time units, specified in the `TimeUnit` property of `sys`. For discrete-time systems with unspecified sample time ($T_s = -1$), `stepplot` interprets `tFinal` as the number of sampling intervals to simulate.

`h = stepplot(___,t)` simulates the step response using the time vector `t`. Specify `t` in the system time units, specified in the `TimeUnit` property of `sys`.

`h = stepplot(AX, ___)` plots the step response on the Axes object in the current figure with the handle `AX`.

`h = stepplot(___, plotoptions)` plots the step response with the options set specified in `plotoptions`. You can use these options to customize the step plot appearance using the command line. Settings you specify in `plotoptions` overrides the preference settings in the MATLAB session in which you run `stepplot`. Therefore, this syntax is useful when you want to write a script to generate multiple plots that look the same regardless of the local preferences.

`h = stepplot(___, dataoptions)` plots the step response with the options set specified in `dataoptions`. You can use this syntax to specify options such as the step amplitude and input offset using the options set `dataoptions`. This syntax is useful when you want to write a script to generate multiple plots with the same option set. Use `stepDataOptions` to create the options set.

Examples

Customize Step Plot using Plot Handle

For this example, use the plot handle to change the time units to minutes and turn on the grid.

Generate a random state-space model with 5 states and create the step response plot with plot handle `h`.

```
rng("default")
sys = rss(5);
h = stepplot(sys);
```

Change the time units to minutes and turn on the grid. To do so, edit properties of the plot handle, `h` using `setoptions`.

```
setoptions(h, 'TimeUnits', 'minutes', 'Grid', 'on');
```

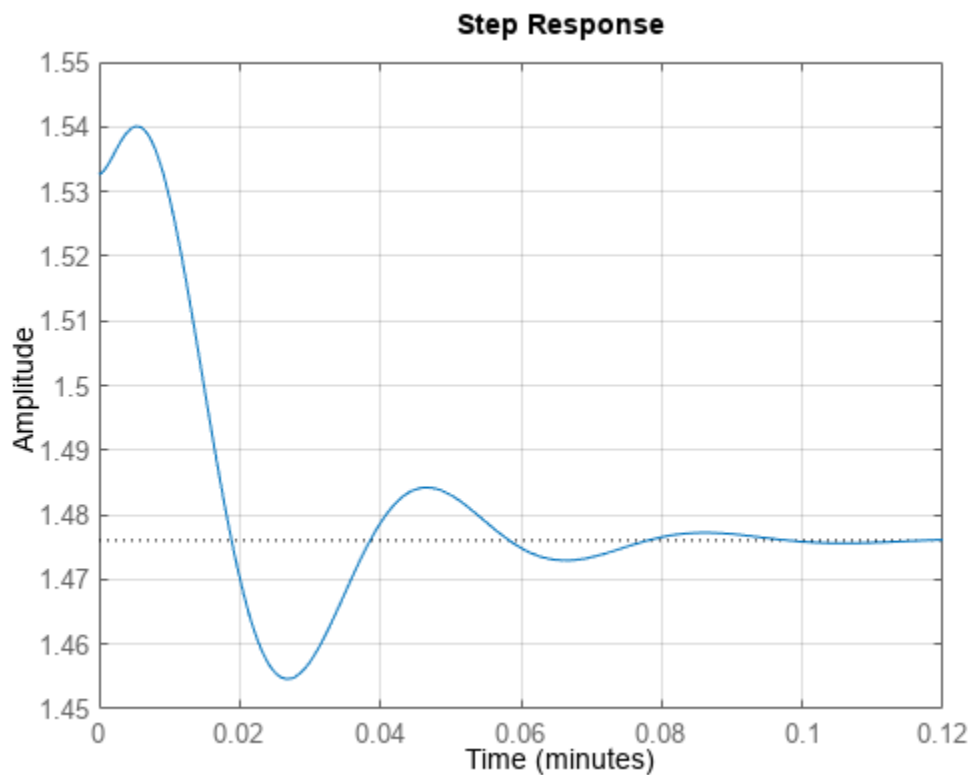

The step plot automatically updates when you call `setoptions`.

Alternatively, you can also use the `timeoptions` command to specify the required plot options. First, create an options set based on the toolbox preferences.

```
plotoptions = timeoptions('cstprefs');
```

Change properties of the options set by setting the time units to minutes and enabling the grid.

```
plotoptions.TimeUnits = 'minutes';  
plotoptions.Grid = 'on';  
stepplot(sys,plotoptions);
```

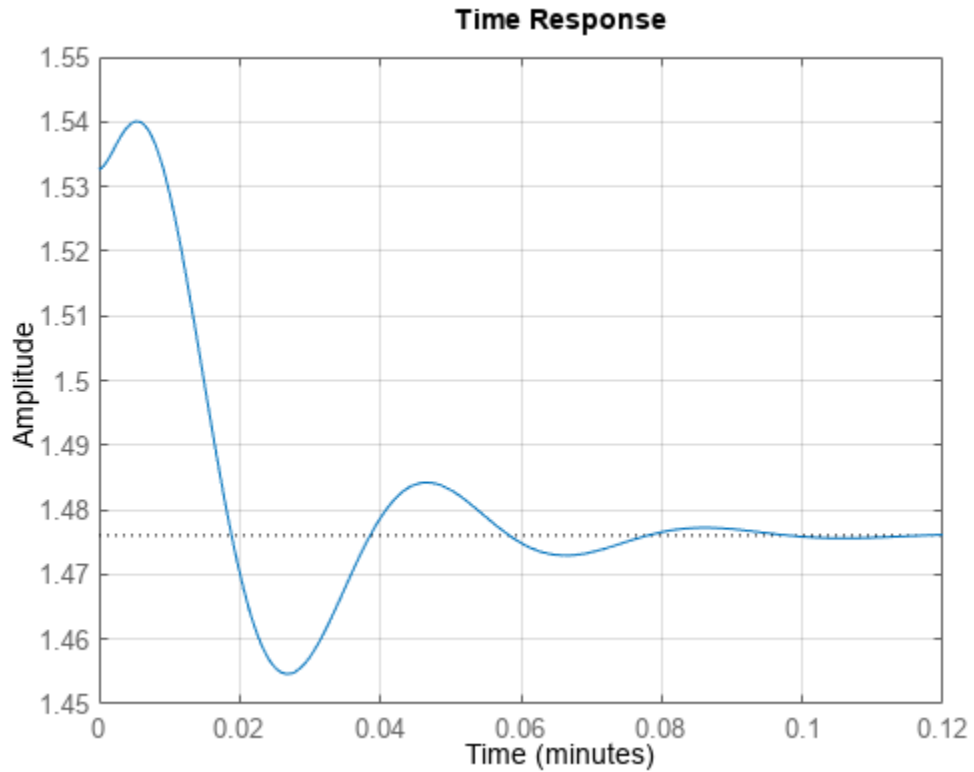

You can use the same option set to create multiple step plots with the same customization. Depending on your own toolbox preferences, the plot you obtain might look different from this plot. Only the properties that you set explicitly, in this example `TimeUnits` and `Grid`, override the toolbox preferences.

Display Normalized Response on Step Plot

Generate a step response plot for two dynamic systems.

```
sys1 = rss(3);  
sys2 = rss(3);  
h = stepplot(sys1,sys2);
```

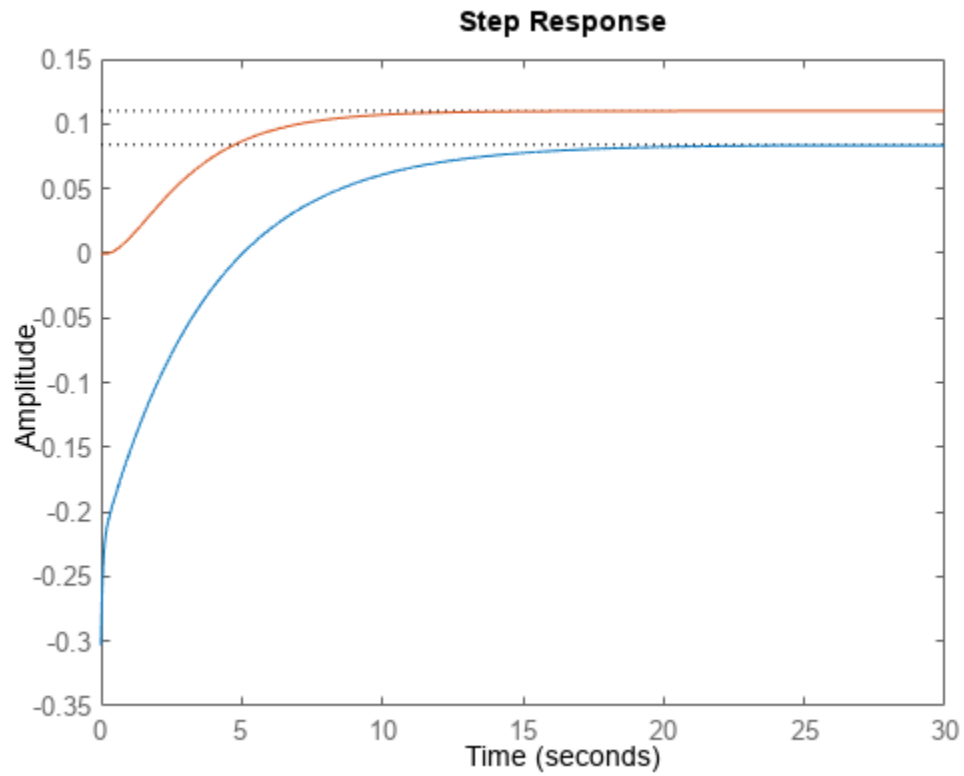

Each step response settles at a different steady-state value. Use the plot handle to normalize the plotted response.

```
setoptions(h, 'Normalize', 'on')
```

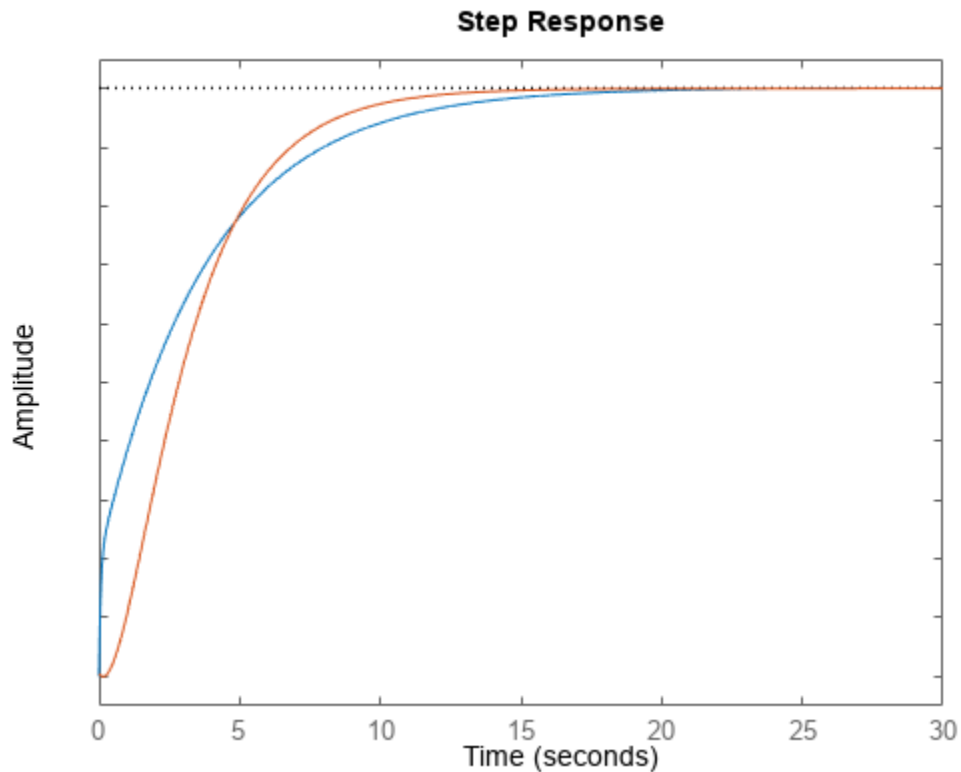

Now, the responses settle at the same value expressed in arbitrary units.

Plot Step Responses of Identified Models with Confidence Region

Compare the step response of a parametric identified model to a nonparametric (empirical) model, and view their 3- σ confidence regions. (Identified models require System Identification Toolbox™ software.)

Identify a parametric and a nonparametric model from sample data.

```
load iddata1 z1
sys1 = ssest(z1,4);
sys2 = impulseest(z1);
```

Plot the step responses of both identified models. Use the plot handle to display the 3- σ confidence regions.

```
t = -1:0.1:5;
h = stepplot(sys1,'r',sys2,'b',t);
showConfidence(h,3)
legend('parametric','nonparametric')
```

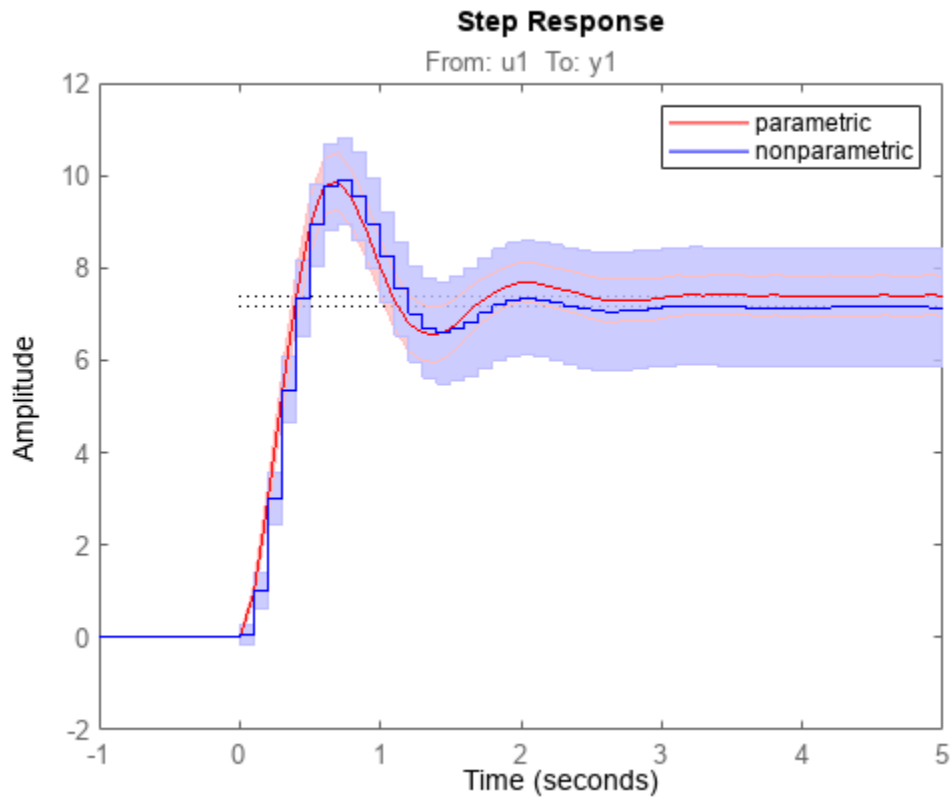

The nonparametric model `sys2` shows higher uncertainty.

Customized Step Response Plot at Specified Time

For this example, examine the step response of the following zero-pole-gain model and limit the step plot to `tFinal = 15` s. Use 15-point blue text for the title. This plot should look the same, regardless of the preferences of the MATLAB session in which it is generated.

```
sys = zpk(-1,[-0.2+3j,-0.2-3j],1)*tf([1 1],[1 0.05]);
tFinal = 15;
```

First, create a default options set using `timeoptions`.

```
plotoptions = timeoptions;
```

Next change the required properties of the options set `plotoptions`.

```
plotoptions.Title.FontSize = 15;
plotoptions.Title.Color = [0 0 1];
```

Now, create the step response plot using the options set `plotoptions`.

```
h = stepplot(sys,tFinal,plotoptions);
```

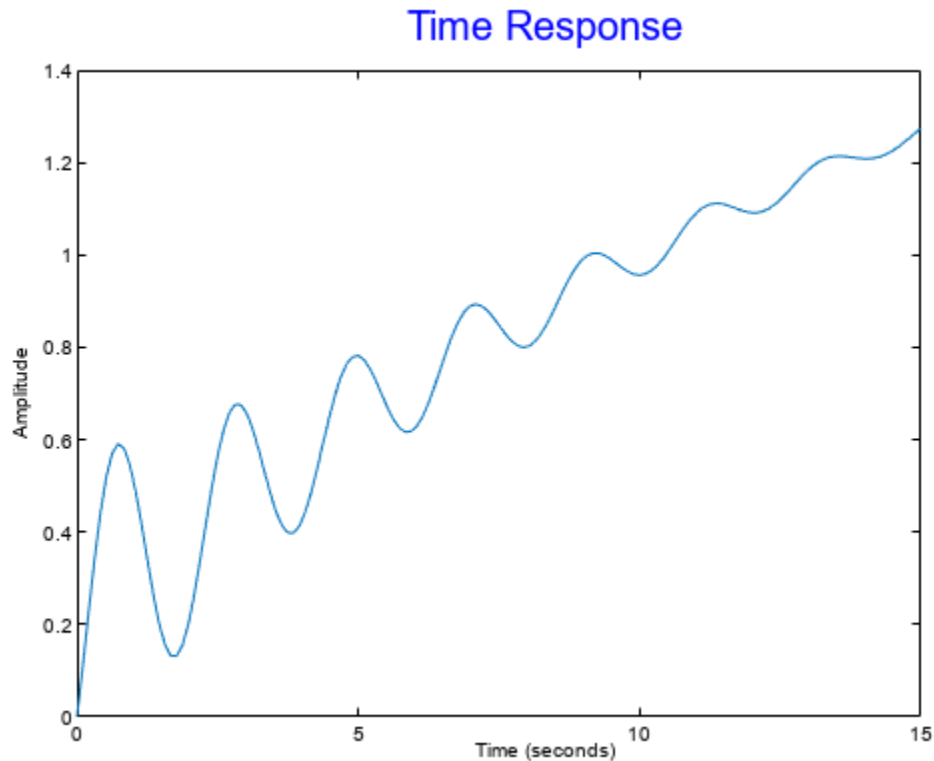

Because `plotoptions` begins with a fixed set of options, the plot result is independent of the toolbox preferences of the MATLAB session.

Plot Step Response of Nonlinear Identified Model

Load data for estimating a nonlinear Hammerstein-Wiener model.

```
load(fullfile(matlabroot,'toolbox','ident','iddemos','data','twotankdata'));
z = iddata(y,u,0.2,'Name','Two tank system');
```

`z` is an `iddata` object that stores the input-output estimation data.

Estimate a Hammerstein-Wiener Model of order [1 5 3] using the estimation data. Specify the input nonlinearity as piecewise linear and output nonlinearity as one-dimensional polynomial.

```
sys = nlhw(z,[1 5 3],idPiecewiseLinear,idPolynomial1D);
```

Create an option set to specify input offset and step amplitude level.

```
opt = stepDataOptions('InputOffset',2,'StepAmplitude',0.5);
```

Plot the step response until 60 seconds using the specified options.

```
stepplot(sys,60,opt);
```

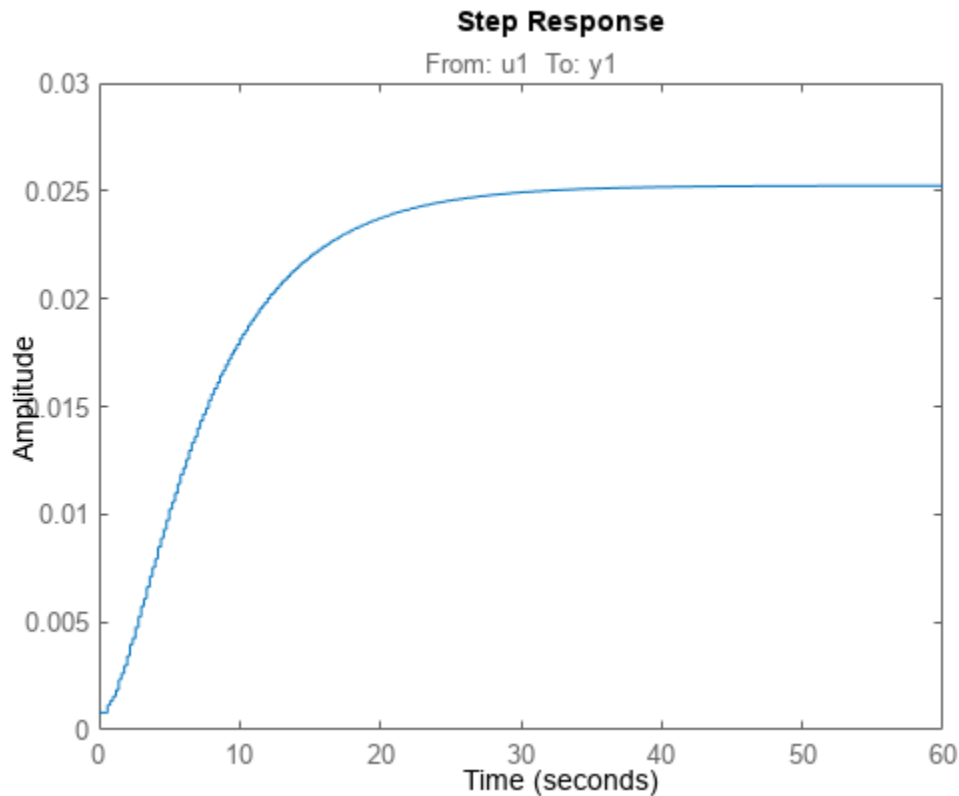

Input Arguments

sys — Dynamic system

dynamic system model | model array

Dynamic system, specified as a SISO or MIMO dynamic system model or array of dynamic system models. Dynamic systems that you can use include:

- Continuous-time or discrete-time numeric LTI models, such as `tf`, `zpk`, or `ss` models.
- Sparse state-space models, such as `sparss` or `mechss` models. Final time `tFinal` must be specified when using sparse models.
- Generalized or uncertain LTI models such as `genss` or `uss` models. (Using uncertain models requires Robust Control Toolbox software.)
 - For tunable control design blocks, the function evaluates the model at its current value to plot the step response data.
 - For uncertain control design blocks, the function plots the nominal value and random samples of the model.
- Identified LTI models, such as `idtf`, `idss`, or `idproc` models. (Using identified models requires System Identification Toolbox software.)

If `sys` is an array of models, the function plots the step response of all models in the array on the same axes.

LineStylec – Line style, marker, and color

character vector | string

Line style, marker, and color, specified as a character vector or string containing symbols. The symbols can appear in any order. You do not need to specify all three characteristics (line style, marker, and color). For example, if you omit the line style and specify the marker, then the plot shows only the marker and no line.

Example: `'--or'` is a red dashed line with circle markers

Line Style	Description
-	Solid line
--	Dashed line
:	Dotted line
-.	Dash-dot line

Marker	Description
'o'	Circle
'+'	Plus sign
'*'	Asterisk
'.'	Point
'x'	Cross
'_'	Horizontal line
' '	Vertical line
's'	Square
'd'	Diamond
'^'	Upward-pointing triangle
'v'	Downward-pointing triangle
'>'	Right-pointing triangle
'<'	Left-pointing triangle
'p'	Pentagram
'h'	Hexagram

Color	Description
y	yellow
m	magenta
c	cyan
r	red
g	green
b	blue
w	white
k	black

tFinal — Final time for step response computation

scalar

Final time for step response computation, specified as a scalar. Specify `tFinal` in the system time units, specified in the `TimeUnit` property of `sys`. For discrete-time systems with unspecified sample time (`Ts = -1`), `stepplot` interprets `tFinal` as the number of sampling intervals to simulate.

t — Time for step response simulation

vector

Time for step response simulation, specified as a vector. Specify the time vector `t` in the system time units, specified in the `TimeUnit` property of `sys`. The time vector must be real, finite, and must contain monotonically increasing and evenly spaced time samples.

The time vector `t` is:

- $t = T_{initial}:T_{sample}:T_{final}$, for discrete-time systems.
- $t = T_{initial}:dt:T_{final}$, for continuous-time systems. Here, dt is the sample time of a discrete approximation of the continuous-time system.

AX — Target axes

Axes object

Target axes, specified as an Axes object. If you do not specify the axes and if the current axes are Cartesian axes, then `stepplot` plots on the current axes. Use `AX` to plot into specific axes when creating a step plot.

plotoptions — Step plot options set

TimePlotOptions object

Step plot options set, specified as a `TimePlotOptions` object. You can use this option set to customize the step plot appearance. Use `timeoptions` to create the option set. Settings you specify in `plotoptions` overrides the preference settings in the MATLAB session in which you run `stepplot`. Therefore, `plotoptions` is useful when you want to write a script to generate multiple plots that look the same regardless of the local preferences.

For the list of available options, see `timeoptions`.

dataoptions — Step response data options set

step object

Step response data options set, specified as a `step` object. Specify options such as the step amplitude and input offset using the options set `dataoptions`. This is useful when you want to write a script to generate multiple plots with the same step amplitude and input offset values. Use `stepDataOptions` to create the options set.

Output Arguments**h** — Plot handle

handle object

Plot handle, returned as a handle object. Use the handle `h` to get and set the properties of the step plot using `getoptions` and `setoptions`. For the list of available options, see the *Properties and Values Reference* section in “Customizing Response Plots from the Command Line”.

Version History

Introduced before R2006a

See Also

[getoptions](#) | [setoptions](#) | [step](#) | [stepDataOptions](#) | [timeoptions](#)

Topics

["Customizing Response Plots from the Command Line"](#)

strseq

Create sequence of indexed character vectors

Syntax

```
txtarray = strseq(TXT,INDICES)
```

Description

`txtarray = strseq(TXT,INDICES)` creates a sequence of indexed character vectors in the cell array `txtarray` by appending the integer values `INDICES` to the character vector `TXT`.

Note You can use `strvec` to aid in system interconnection. For an example, see the `sumblk` reference page.

Examples

Create a Cell Array of Indexed Text

Index the text 'e' with the numbers 1, 2, and 4.

```
txtarray = strseq('e',[1 2 4])
```

```
txtarray = 3x1 cell
    {'e1'}
    {'e2'}
    {'e4'}
```

Version History

Introduced in R2008b

See Also

`strcat` | `connect`

sumblk

Summing junction for name-based interconnections

Syntax

```
S = sumblk(formula)
S = sumblk(formula,signalsize)
S = sumblk(formula,signames1,...,signamesN)
```

Description

`S = sumblk(formula)` creates the summing junction described by `formula` in the form of a transfer function (tf) model, `S`. The string `formula` specifies an equation that relates the scalar input and output signals of `S`, such as "`e = r - y`". The function sets the `InputName` and `OutputName` properties of `S` based on `formula`. Use `S` in conjunction with `connect` to interconnect dynamic system models and derive aggregate models for block diagrams.

`S = sumblk(formula,signalsize)` returns a vector-valued summing junction. The input and output signals are vectors with `signalsize` elements. `sumblk` sets the `InputName` and `OutputName` properties by vector expansion of the signal names in `formula`.

`S = sumblk(formula,signames1,...,signamesN)` replaces placeholders in `formula` by the signal names `signames`. Indicate a placeholder in `formula` by using a signal name beginning with `%`. The number of `signames` arguments must match the number of placeholders in `formula`. The first placeholder in `formula` is replaced by `signames1`, the second by `signames2`, and so on.

Examples

Summing Junction with Scalar-Valued Signals

Create the summing junction of the following illustration. All signals are scalar-valued.

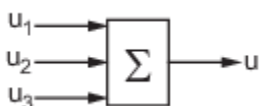

This summing junction has the formula $u = u_1 + u_2 + u_3$. Use this formula with `sumblk` to create the summing junction.

```
S = sumblk('u = u1 + u2 + u3');
```

`S` is the transfer function (tf) representation of the sum $u = u_1 + u_2 + u_3$. That is, `S` is a static-gain tf with three inputs and one output, which is equal to the sum of the inputs. The transfer function `S` gets its input and output names from the formula.

```
S.OutputName
```

```
ans = 1x1 cell array
    {'u'}
```

S.InputName

```
ans = 3x1 cell
    {'u1'}
    {'u2'}
    {'u3'}
```

Therefore, you can use `S` with the name-based syntax of the `connect` command to build aggregate models such as the system of the following block diagram.

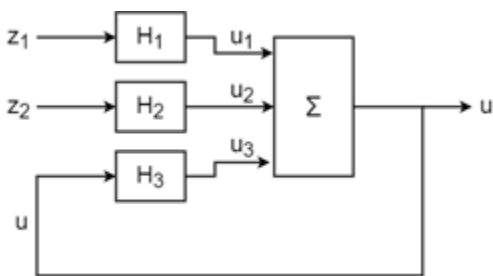

To do so, create LTI models for `H1`, `H2`, and `H3`, and name their inputs and outputs according to the diagram. For this example, use transfer functions.

```
H1 = tf(1,[1 2],"InputName","z1","OutputName","u1");
H2 = tf([1 -2],[1 1],"InputName","z2","OutputName","u2");
H3 = tf(2,[2 1],"InputName","u","OutputName","u3");
```

Connect the models and the summing junction to create an aggregate model with inputs `z1` and `z2` and output `u`. The `connect` command automatically connects the outputs of the components to inputs with matching names.

```
T = connect(H1,H2,H3,S,{"z1","z2"},{"u"});
T.InputName
```

```
ans = 2x1 cell
    {'z1'}
    {'z2'}
```

T.OutputName

```
ans = 1x1 cell array
    {'u'}
```

Summing Junction with Vector-Valued Signals

Create the summing junction $v = u - d$ where u , d , v are vector-valued signals of length 2. This summing junction is shown in the following diagram, where each arrow represents two signals.

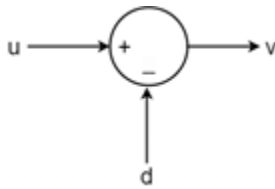

This summing junction outputs $v(1) = u(1) - d(1)$ and $v(2) = u(2) - d(2)$. To create this junction using `sumblk`, specify both the formula and the signal length.

```
S = sumblk('v = u - d',2);
size(S)
```

Transfer function with 2 outputs and 4 inputs.

The result is a transfer function with four inputs and two outputs: two inputs each for `d` and `u`, and two outputs for `v`. `sumblk` automatically performs vector expansion of the signal names and assigns them to `S.InputName` and `S.OutputName`.

`S.InputName`

```
ans = 4x1 cell
    {'u(1)'}
    {'u(2)'}
    {'d(1)'}
    {'d(2)'}
```

`S.OutputName`

```
ans = 2x1 cell
    {'v(1)'}
    {'v(2)'}
```

You can connect `S` to other dynamic system models to build aggregate models, as you would use any other MIMO transfer function. For instance, suppose that you want to create a model representing the following two-channel feedback loop, that is, a feedback loop in which each line in the diagram represents two signals.

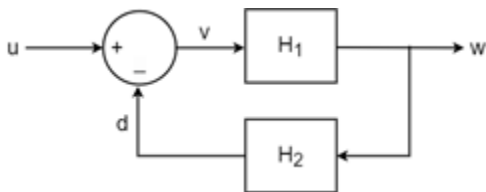

Create two-input, two-output models for `H1` and `H2`, and set their `InputName` and `OutputName` properties as indicated by the diagram. For this example, use random state-space models.

```
H1 = rss(3,2,2);
H1.InputName = 'v';
H1.OutputName = 'w';
```

```
H2 = rss(3,2,2);
H2.InputName = 'w';
H2.OutputName = 'd';
```

Note that the signal names in the dynamic system models are automatically expanded, just as `sumblk` expands the signal names of `S`. For instance, examine the outputs of `H1`.

```
H1.OutputName
```

```
ans = 2x1 cell
      {'w(1)'}
      {'w(2)'}

```

The `connect` command also performs this expansion. Thus, you can assemble the aggregate system with the following command.

```
T = connect(S,H1,H2,'u','w');
size(T)
```

```
State-space model with 2 outputs, 2 inputs, and 6 states.
```

Specify Individual Names in Summing Junction with Vector-Valued Signals

As shown in the example “Summing Junction with Vector-Valued Signals” on page 2-1340, when you create a summing junction for vector signals, by default `sumblk` appends an index to the signal names that you provide. If you need to specify distinct signal names instead of this vector expansion, use a placeholder in the summing-junction formula to represent the signals you want to name. Then, use the `signames` input argument to provide the specific names to substitute for the placeholder in creating the summing junction.

For instance, create a summing junction having the following formula.

$$e(1) = \text{setpoint}(1) - \text{alpha}$$

$$e(2) = \text{setpoint}(2) - q$$

This formula is the summing junction shown in the following diagram, where `setpoint` represents two inputs and `e` represents two outputs.

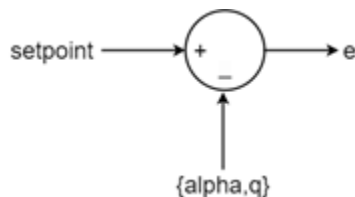

To create this summing junction, allow `sumblk` to expand `e` and `setpoint`, but use a signal name beginning with `%` as a placeholder for the specific signal names you provide in the `signames` argument.

```
formula = 'e = setpoint - %y';
signames = ["alpha","q"];
S = sumblk(formula,signames);
```

`sumblk` replaces the placeholder `%y` with the signal names `alpha` and `q` and expands the other signal names. Note that `sumblk` takes the size of the vector signals from the number of signals in `signames`. Thus, the `setpoint` input and `e` output of `S` each contain two signals.

S.InputName

```
ans = 4x1 cell
      {'setpoint(1)'}
      {'setpoint(2)'}
      {'alpha'      }
      {'q'          }
```

S.OutputName

```
ans = 2x1 cell
      {'e(1)'}
      {'e(2)'}

```

This syntax is particularly useful when you want to create a summing junction to connect existing models whose `InputName` or `OutputName` properties are already set. For instance, consider the following two-input, two-output state-space model.

```
A = [-0.004 0.03; 0.03 -0.19];
B = [0.3 0.2; -0.06 0];
C = [0.99 0.5; 0 0];
D = 0;
G = ss(A,B,C,D);
G.InputName = {'angle','rate'};
G.OutputName = {'current','temp'};
```

Create a summing junction that subtracts the outputs of G from a pair of reference inputs, such that

$$e(1) = \text{ref}(1) - \text{current}$$

$$e(2) = \text{ref}(2) - \text{temp}$$

To do so, use a placeholder for these signals in the formula. Then, use `G.OutputName` as the `signames` input.

```
S = sumblk('e = ref - %outputs',G.OutputName);
S.InputName
```

```
ans = 4x1 cell
      {'ref(1)'}
      {'ref(2)'}
      {'current'}
      {'temp'   }
```

You can use multiple placeholders to replace multiple elements of the formula. `sumblk` replaces the placeholders in the order you provide them. For instance, give the reference signals specific names instead of `ref(1)` and `ref(2)`.

```
refnames = ["refcur","reftemp"];
S = sumblk('e = %refs - %outputs',refnames,G.OutputName);
S.InputName
```

```
ans = 4x1 cell
      {'refcur'}
      {'reftemp'}
      {'current'}
```

```
{'temp' }
```

Input Arguments

formula — Equation relating input and output signals of summing junction

string | character vector

Equation that relates the input and output signals of the summing junction transfer function S , specified as a string or character vector. For example, consider the summing junction of the following diagram.

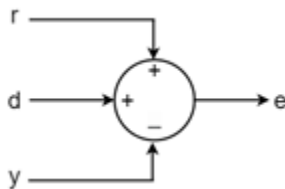

To represent this summing junction as a three-input, one-output transfer function, use the following commands.

```
formula = "e = r + d - y";
S = sumblk(formula);
```

For vector-valued signals, you can optionally use one or more placeholders in `formula` to control the names that `sumblk` assigns to `S.InputName` and `S.OutputName`. To put a placeholder in `formula`, use a signal name that begins with `%`. When assigning signal names to `S`, the `sumblk` command replaces each placeholder with the names you provide in the `signames` argument.

Such placeholders are particularly useful for creating summing junctions for connecting existing models that have named signals. For example, if `C` and `G` are dynamic system models with nonempty `InputName` and `OutputName` properties, respectively, you can create a summing junction using the following expression.

```
S = sumblk("%e = r - %y",C.InputName,G.OutputName)
```

`sumblk` uses the values of `C.InputName` and `G.OutputName` in place of `%e` and `%y`, respectively. The vector dimension of `C.InputName` and `G.OutputName` must match. `sumblk` assigns the signal `r` the same dimension. For an example, see “Specify Individual Names in Summing Junction with Vector-Valued Signals” on page 2-1342.

signalsize — Number of elements in each signal

1 (default) | positive integer

Number of elements in each input and output signal of S , specified as a positive integer. Setting `signalsize` greater than 1 lets you specify a summing junction that operates on vector-valued signals. For instance, `S = sumblk("e = r - y",2)` creates a summing junction where each of the inputs `r` and `y` and the output `e` is a vector signal with two elements. See “Summing Junction with Vector-Valued Signals” on page 2-1340.

signames — Substitute signal names for a placeholder

string array | cell array of character vectors

Substitute signal names for a placeholder (signal name beginning with %) in the argument `formula`, specified as a string array or a cell array of character vectors. Provide one `signames` argument for each placeholder in `formula`.

Specify `signames` as:

- A string array, such as `["alpha", "q"]`.
- A cell array of signal names, such as `{'alpha', 'q'}`.
- The `InputName` or `OutputName` property of a model in the MATLAB workspace. For example:

```
S = sumblk("%e = r - y", C.InputName)
```

This command creates a summing junction whose outputs have the same name as the inputs of the model `C` in the MATLAB workspace. For an example showing how to use `signames`, see “Specify Individual Names in Summing Junction with Vector-Valued Signals” on page 2-1342.

If you use placeholders and the `signames` argument, then `sumblk` sets the vector length of the signals of `S`. If you use multiple placeholders, then all `signames` arguments must have the same number of signals.

Output Arguments

S — Transfer function for summing junction

`tf` model

Transfer function for the summing junction, returned as a `tf` model.

`sumblk` sets the `InputName` and `OutputName` properties of `S` using the signal names in `formula`. For instance, if you enter `S = sumblk("e = r + d - y")`, then `sumblk` creates `S` with `S.InputName = {'r'; 'd'; 'y'}` and `S.OutputName = {'e'}`. Use these input and output names to interconnect `S` with other dynamic system models to build composite systems. For an example, see “Summing Junction with Scalar-Valued Signals” on page 2-1339.

If `signalsize` is greater than 1, then `S` has `signalsize` inputs (or outputs) per signal name in `formula`. The function sets `S.InputName` and `S.OutputName` by applying vector expansion to the signal name specified in `formula`, such as `{'e(1)', 'e(2)', ...}`. For an example, see “Summing Junction with Vector-Valued Signals” on page 2-1340.

If you use placeholders in `formula`, then `sumblk` sets the `InputName` and `OutputName` properties of `S` using the names you provide in `signames`. For an example, see “Specify Individual Names in Summing Junction with Vector-Valued Signals” on page 2-1342.

Version History

Introduced in R2008a

See Also

`connect` | `series` | `parallel`

Topics

“Multi-Loop Control System”

“MIMO Control System”

systune

Tune fixed-structure control systems modeled in MATLAB

Syntax

```
[CL,fSoft] = systune(CL0,SoftReqs)
[CL,fSoft,gHard] = systune(CL0,SoftReqs,HardReqs)
[CL,fSoft,gHard] = systune(CL0,SoftReqs,HardReqs,options)
[CL,fSoft,gHard,info] = systune( ___ )
```

Description

`systune` tunes fixed-structure control systems subject to both soft and hard design goals. `systune` can tune multiple fixed-order, fixed-structure control elements distributed over one or more feedback loops. For an overview of the tuning workflow, see “Automated Tuning Workflow”.

This command tunes control systems modeled in MATLAB. For tuning Simulink models, use `sITuner` to create an interface to your Simulink model. You can then tune the control system with `systune` for `sITuner`.

`[CL,fSoft] = systune(CL0,SoftReqs)` tunes the free parameters of the control system model, `CL0`, to best meet the soft tuning requirements. The best achieved soft constraint values are returned as `fSoft`. For robust tuning against real parameter uncertainty, use a control system model with uncertain real parameters. For robust tuning against a set of plant models, use an array of control system models `CL0`. (See “Input Arguments” on page 2-1355.)

`[CL,fSoft,gHard] = systune(CL0,SoftReqs,HardReqs)` tunes the control system to best meet the soft tuning requirements subject to satisfying the hard tuning requirements (constraints). It returns the best achieved values for the soft and hard constraints.

`[CL,fSoft,gHard] = systune(CL0,SoftReqs,HardReqs,options)` specifies options for the optimization.

`[CL,fSoft,gHard,info] = systune(___)` also returns detailed information about each optimization run. All input arguments described for the previous syntaxes also apply here.

Examples

Tune Control System to Soft Requirements

Tune a cascaded control system to meet requirements of reference tracking and disturbance rejection.

The cascaded control system of the following illustration includes two tunable controllers, the PI controller for the inner loop, C_2 , and the PID controller for the outer loop, C_1 .

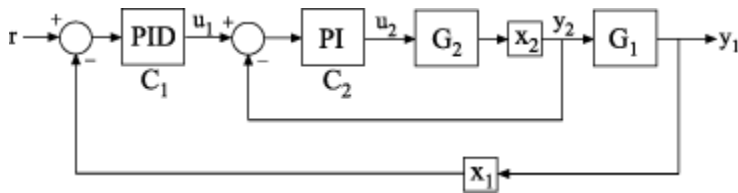

The blocks x_1 and x_2 mark analysis-point locations. These are locations at which loops can be opened or signals injected for the purpose of specifying requirements for tuning the system.

Tune the free parameters of this control system to meet the following requirements:

- The output signal, y_1 , tracks the reference signal, r , with a response time of 10 seconds and a steady-state error of 1%.
- A disturbance injected at x_2 is suppressed at y_1 by a factor of 10.

Create tunable Control Design Blocks to represent the controllers, and numeric LTI models to represent the plants. Also, create `AnalysisPoint` blocks to mark the points of interest in each feedback loop.

```
G2 = zpk([], -2, 3);
G1 = zpk([], [-1 -1 -1], 10);

C20 = tunablePID('C2', 'pi');
C10 = tunablePID('C1', 'pid');

X1 = AnalysisPoint('X1');
X2 = AnalysisPoint('X2');
```

Connect these components to build a model of the entire closed-loop control system.

```
InnerLoop = feedback(X2*G2*C20, 1);
CL0 = feedback(G1*InnerLoop*C10, X1);
CL0.InputName = 'r';
CL0.OutputName = 'y';
```

`CL0` is a tunable `genss` model. Specifying names for the input and output channels allows you to identify them when you specify tuning requirements for the system.

Specify tuning requirements for reference tracking and disturbance rejection.

```
Rtrack = TuningGoal.Tracking('r', 'y', 10, 0.01);
Rreject = TuningGoal.Gain('X2', 'y', 0.1);
```

The `TuningGoal.Tracking` requirement specifies that the signal at 'y' track the signal at 'r' with a response time of 10 seconds and a tracking error of 1%.

The `TuningGoal.Gain` requirement limits the gain from the implicit input associated with the `AnalysisPoint` block, X_2 , to 'y'. (See `AnalysisPoint`.) Limiting this gain to a value less than 1 ensures that a disturbance injected at X_2 is suppressed at the output.

Tune the control system.

```
[CL, fSoft] = systune(CL0, [Rtrack, Rreject]);
Final: Soft = 1.24, Hard = -Inf, Iterations = 106
```

`systune` converts each tuning requirement into a normalized scalar value, f . The command adjusts the tunable parameters of `CL0` to minimize the f values. For each requirement, the requirement is satisfied if $f < 1$ and violated if $f > 1$. `fSoft` is the vector of minimized f values. The largest of the minimized f values is displayed as `Soft`.

The output model `CL` is the tuned version of `CL0`. `CL` contains the same Control Design Blocks as `CL0`, with current values equal to the tuned parameter values.

Validate that the tuned control system meets the tracking requirement by examining the step response from 'r' to 'y'.

```
stepplot(CL)
```

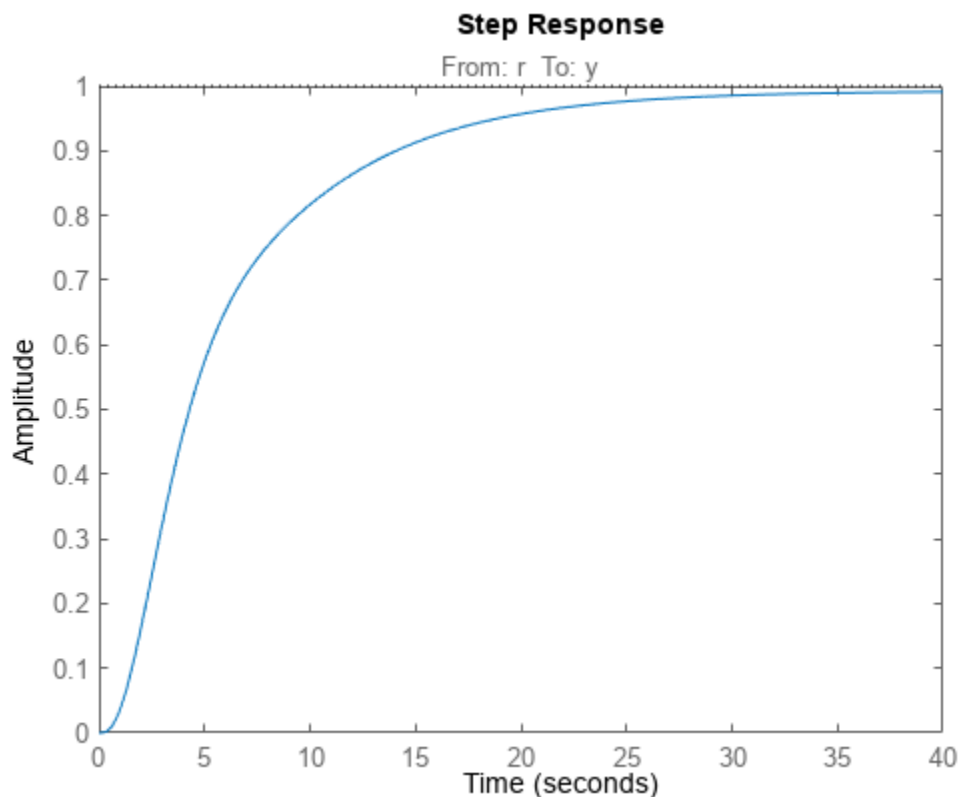

The step plot shows that in the tuned control system, `CL`, the output tracks the input with approximately the desired response time.

Validate the tuned system against the disturbance rejection requirement by examining the closed-loop response to a signal injected at `X2`.

```
CLdist = getIOTransfer(CL, 'X2', 'y');
stepplot(CLdist);
```

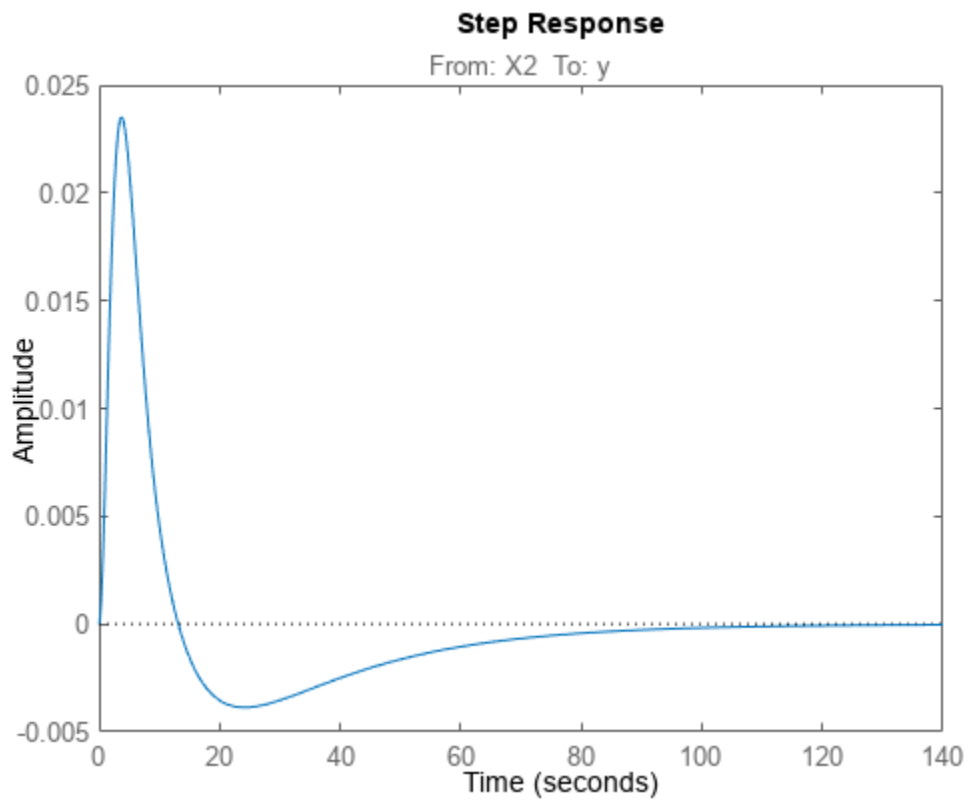

`getIOTransfer` extracts the closed-loop response from the specified inputs to outputs. In general, `getIOTransfer` and `getLoopTransfer` are useful for validating a control system tuned with `systemtune`.

You can also use `viewGoal` to compare the responses of the tuned control system directly against the tuning requirements, `Rtrack` and `Rreject`.

```
viewGoal([Rtrack,Rreject],CL)
```

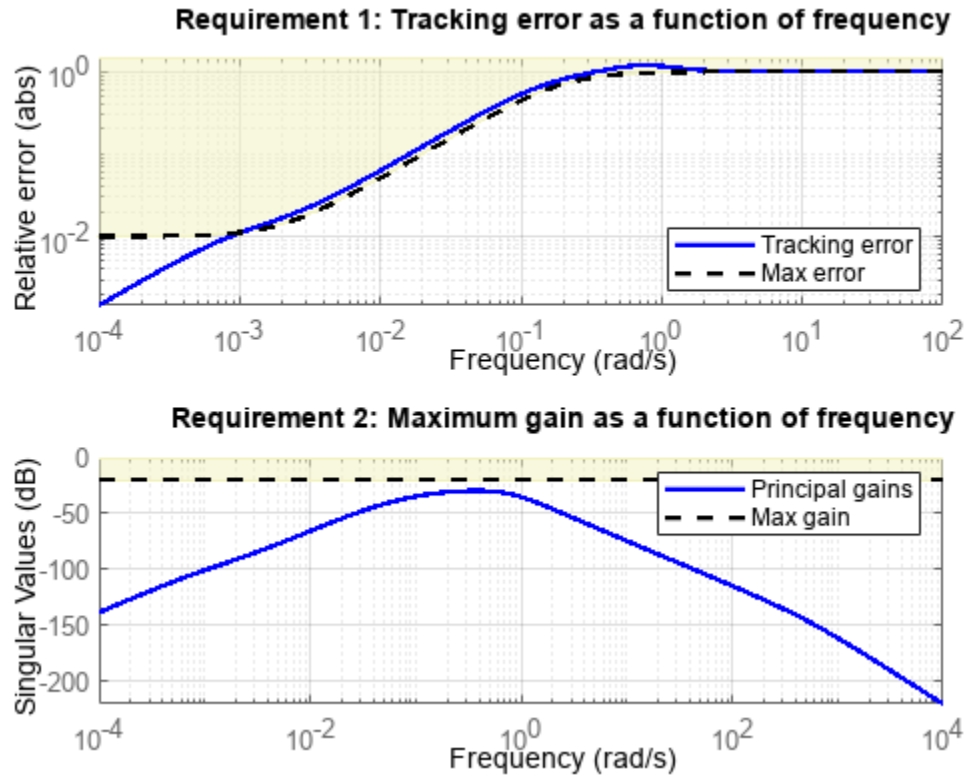
Tune Control System to Both Hard and Soft Requirements

Tune a cascaded control system to meet requirements of reference tracking and disturbance rejection. These requirements are subject to a hard constraint on the stability margins of the inner and outer loops.

The cascaded control system of the following illustration includes two tunable controllers, the PI controller for the inner loop, C_2 , and the PID controller for the outer loop, C_1 .

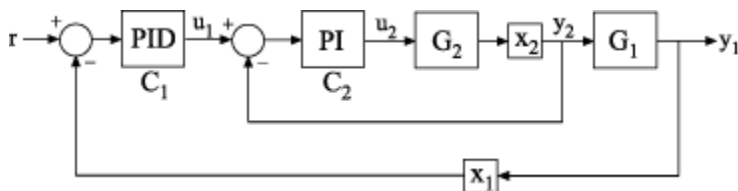

The blocks x_1 and x_2 mark analysis-point locations. These are locations at which you can open loops or inject signals for the purpose of specifying requirements for tuning the system.

Tune the free parameters of this control system to meet the following requirements:

- The output signal, y_1 , tracks the reference signal at r with a response time of 5 seconds and a steady-state error of 1%.

- A disturbance injected at x_2 is suppressed at the output, y_1 , by a factor of 10.

Impose these tuning requirements subject to hard constraints on the stability margins of both loops.

Create tunable Control Design Blocks to represent the controllers and numeric LTI models to represent the plants. Also, create `AnalysisPoint` blocks to mark the points of interest in each feedback loop.

```
G2 = zpk([], -2, 3);
G1 = zpk([], [-1 -1 -1], 10);

C20 = tunablePID('C2', 'pi');
C10 = tunablePID('C1', 'pid');

X1 = AnalysisPoint('X1');
X2 = AnalysisPoint('X2');
```

Connect these components to build a model of the entire closed-loop control system.

```
InnerLoop = feedback(X2*G2*C20, 1);
CL0 = feedback(G1*InnerLoop*C10, X1);
CL0.InputName = 'r';
CL0.OutputName = 'y';
```

`CL0` is a tunable `genss` model. Specifying names for the input and output channels allows you to identify them when you specify tuning requirements for the system.

Specify tuning requirements for reference tracking and disturbance rejection.

```
Rtrack = TuningGoal.Tracking('r', 'y', 5, 0.01);
Rreject = TuningGoal.Gain('X2', 'y', 0.1);
```

The `TuningGoal.Tracking` requirement specifies that the signal at 'y' tracks the signal at 'r' with a response time of 5 seconds and a tracking error of 1%.

The `TuningGoal.Gain` requirement limits the gain from the implicit input associated with the `AnalysisPoint` block `X2` to the output, 'y'. (See `AnalysisPoint`.) Limiting this gain to a value less than 1 ensures that a disturbance injected at `X2` is suppressed at the output.

Specify tuning requirements for the gain and phase margins.

```
RmarginOut = TuningGoal.Margins('X1', 18, 60);
RmarginIn = TuningGoal.Margins('X2', 18, 60);
RmarginIn.Openings = 'X1';
```

`RmarginOut` imposes a minimum gain margin of 18 dB and a minimum phase margin of 60 degrees. Specifying `X1` imposes that requirement on the outer loop. Similarly, `RmarginIn` imposes the same requirements on the inner loop, identified by `X2`. To ensure that the inner-loop margins are evaluated with the outer loop open, include the outer-loop analysis-point location, `X1`, in `RmarginIn.Openings`.

Tune the control system to meet the soft requirements of tracking and disturbance rejection, subject to the hard constraints of the stability margins.

```
SoftReqs = [Rtrack, Rreject];
HardReqs = [RmarginIn, RmarginOut];
[CL, fSoft, gHard] = systune(CL0, SoftReqs, HardReqs);
```

```
Final: Soft = 1.13, Hard = 0.97769, Iterations = 111
```

systeme converts each tuning requirement into a normalized scalar value, f for the soft constraints and g for the hard constraints. The command adjusts the tunable parameters of CL0 to minimize the f values, subject to the constraint that each $g < 1$.

The displayed value `Hard` is the largest of the minimized g values in `gHard`. This value is less than 1, indicating that both the hard constraints are satisfied.

Validate the tuned control system against the stability margin requirements.

```
figure;
viewGoal(HardReqs,CL)
```

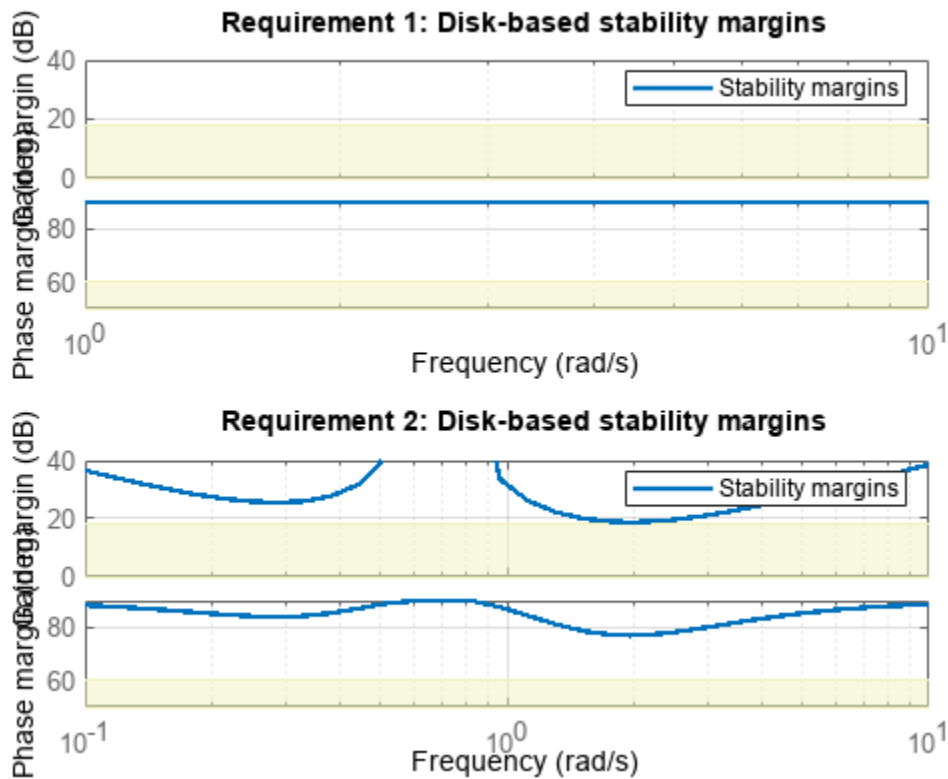

The `viewGoal` plot confirms that the stability margin requirements for both loops are satisfied by the tuned control system at all frequencies. The blue lines show the margin used in the optimization calculation, which is an upper bound on the actual margin of the tuned control system.

Examine whether the tuned control system meets the tracking requirement by examining the step response from 'r' to 'y'.

```
figure;
stepplot(CL,20)
```

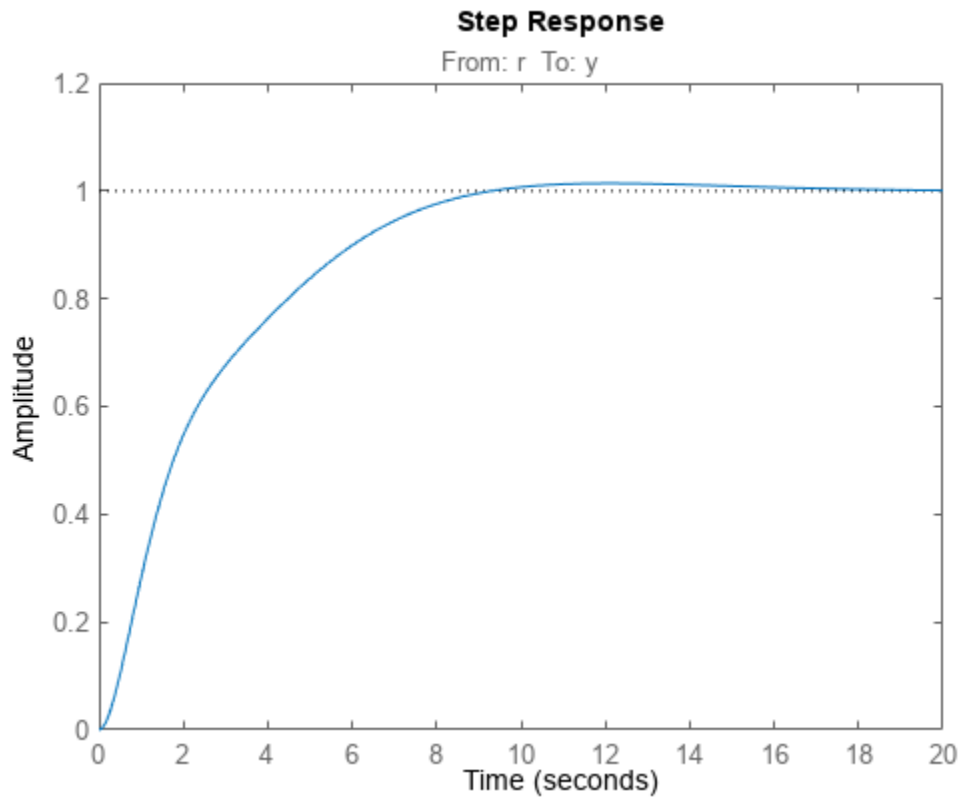

The step plot shows that in the tuned control system, CL, the output tracks the input but the response is somewhat slower than desired and the tracking error may be larger than desired. For further information, examine the tracking requirement directly with `viewGoal`.

```
figure;  
viewGoal(Rtrack,CL)
```

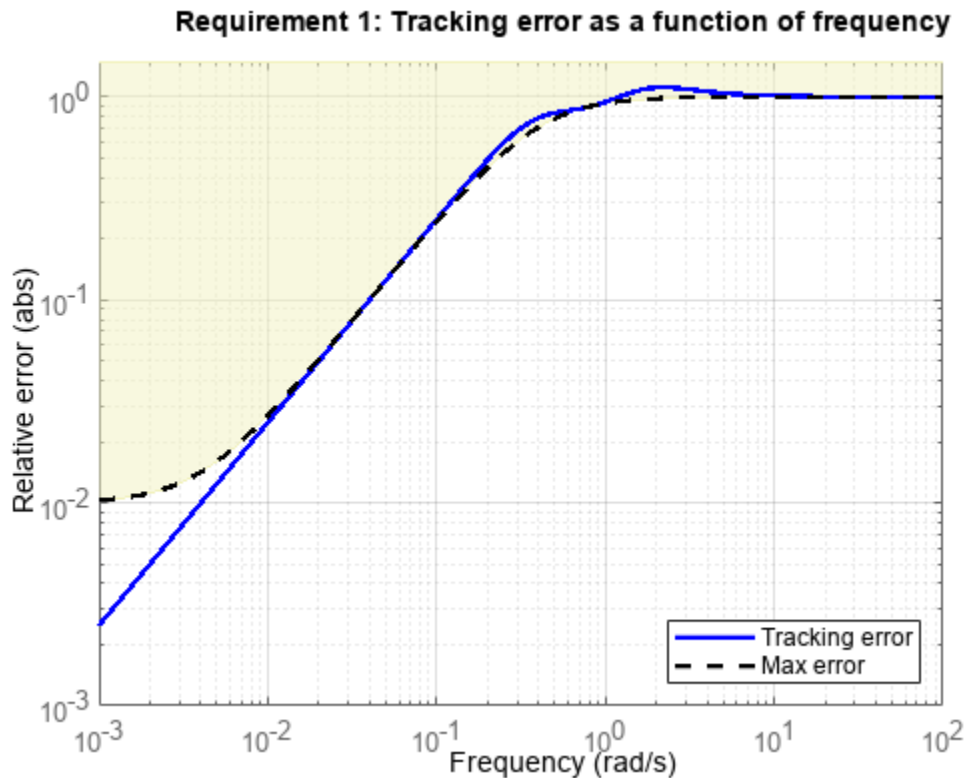

The actual tracking error crosses into the shaded area between 1 and 10 rad/s, indicating that the requirement is not met in this regime. Thus, the tuned control system cannot meet the soft tracking requirement, time subject to the hard constraints of the stability margins. To achieve the desired performance, you may need to relax one of your requirements or convert one or more hard constraints to soft constraints.

Input Arguments

CL0 — Control system to tune

generalized state-space model | model array

Control system to tune, specified as a generalized state-space (`genss`) model or array of models with tunable parameters. To construct CL0:

- 1 Parameterize the tunable elements of your control system. You can use predefined structures, such as `tunablePID`, `tunableGain`, and `tunableTF`. Alternatively, you can create your own structure from elementary tunable parameters (`realp`).
- 2 Build a closed-loop model of the overall control system as an interconnection of fixed and tunable components. To do so, use model interconnection commands such as `feedback` and `connect`. Use `AnalysisPoint` blocks to mark additional signals of interest for specifying and assessing tuning requirements.

For more information about creating models to tune, see “Setup for Tuning Control System Modeled in MATLAB”.

For robust tuning of a control system against a set of plant models (requires Robust Control Toolbox), specify an array of tunable `genss` models that have the same tunable parameters. To make the controller robust against parameter uncertainty, use a model with uncertain real parameters defined with `ureal` or `uss`. In this case, `CL0` is a `genss` model that contains both tunable and uncertain control design blocks. For more information about robust tuning, see “Robust Tuning Approaches” (Robust Control Toolbox).

SoftReqs — Soft tuning goals (objectives)

vector of `TuningGoal` objects

Soft tuning goals (objectives) for tuning the control system, specified as a vector of `TuningGoal` objects. These objects capture your design requirements, such as `TuningGoal.Tracking`, `TuningGoal.StepTracking`, or `TuningGoal.Margins`.

`systemtune` tunes the tunable parameters of the control system to minimize the soft tuning goals. This tuning is subject to satisfying the hard tuning goals (if any).

For more information about available tuning goals, see “Tuning Goals”.

HardReqs — Hard tuning goals (constraints)

`[]` (default) | vector of `TuningGoal` objects

Hard tuning goals (constraints) for tuning the control system, specified as a vector of `TuningGoal` objects. These objects capture your design requirements, such as `TuningGoal.Tracking`, `TuningGoal.StepTracking`, or `TuningGoal.Margins`.

`systemtune` converts each hard tuning goal to a normalized scalar value. `systemtune` then optimizes the free parameters to minimize those normalized values. A hard goal is satisfied if the normalized value is less than 1.

For more information about available tuning goals, see “Tuning Goals”.

options — Options for tuning algorithm

`systemtuneOptions` object

Options for the tuning algorithm, specified as an options set you create with `systemtuneOptions`. Available options include:

- Number of additional optimizations to run. Each optimization starts from random initial values of the free parameters.
- Tolerance for terminating the optimization.
- Flag for using parallel processing.

See the `systemtuneOptions` reference page for more details about all available options.

Output Arguments**CL — Tuned control system**

generalized state-space model

Tuned control system, returned as a generalized state-space (`genss`) model. This model has the same number and type of tunable elements (Control Design Blocks) as `CL0`. The current values of these elements are the tuned parameters. Use `getBlockValue` or `showTunable` to access values of the tuned elements.

If you provide an array of control system models to tune as the input argument, `CL0`, `systune` tunes the parameters of all the models simultaneously. In this case, `CL` is an array of tuned `genss` models. For more information, see “Robust Tuning Approaches” (Robust Control Toolbox).

fSoft — Best achieved soft constraint values

vector

Best achieved soft constraint values, returned as a vector. `systune` converts the soft requirements to a function of the free parameters of the control system. The command then tunes the parameters to minimize that function subject to the hard constraints. (See “Algorithms” on page 2-1359.) `fSoft` contains the best achieved value for each of the soft constraints. These values appear in `fSoft` in the same order that the constraints are specified in `SoftReqs`. `fSoft` values are meaningful only when the hard constraints are satisfied.

gHard — Best achieved hard constraint values

vector

Best achieved hard constraint values, returned as a vector. `systune` converts the hard requirements to a function of the free parameters of the control system. The command then tunes the parameters to drive those values below 1. (See “Algorithms” on page 2-1359.) `gHard` contains the best achieved value for each of the hard constraints. These values appear in `gHard` in the same order that the constraints are specified in `HardReqs`. If all values are less than 1, then the hard constraints are satisfied.

info — Detailed information about optimization runs

structure

Detailed information about each optimization run, returned as a data structure. The fields of `info` are summarized in the following table.

Field	Value
Run	Run number, returned as a scalar. If you use the <code>RandomStart</code> option of <code>systuneOptions</code> to perform multiple optimization runs, <code>info</code> is a structure array, and <code>info.Run</code> is the index.
Iterations	Total number of iterations performed during the run, returned as a scalar. If you use <code>RandomStart</code> , <code>info.Iterations(j)</code> is the number of iterations performed in the <i>j</i> th run before termination.
f	Best overall soft constraint value, returned as a scalar. <code>systune</code> converts the soft tuning goals to a function of the free parameters of the control system. The command then tunes the parameters to minimize that function subject to the hard goals. (See “Algorithms” on page 2-1359.) <code>info.f</code> is the maximum soft goal value at the final iteration. This value is meaningful only when the hard goals are satisfied. If the value is less than 1, then the soft goals are also attained.
g	Best overall hard constraint value, returned as a scalar. <code>systune</code> converts the hard tuning goals to a function of the free parameters of the control system. The command then tunes the parameters to drive those values below 1. (See “Algorithms” on page 2-1359.) <code>info.g</code> is the largest hard goal value at the final iteration. If this value is less than 1, then the hard goals are satisfied.

Field	Value
x	<p>Tuned parameter values, returned as a vector. This vector contains the values of the tunable parameters at the end of the run. <code>info.x</code> can also include the values of additional variables such as loop scalings, if <code>systeme</code> uses them (see <code>info.LoopScaling</code>).</p>
MinDecay	<p>Minimum decay rate of tuned system dynamics, returned as a two-element row vector.</p> <p><code>info.MinDecay(1)</code> is the minimum decay rate of the closed-loop poles.</p> <p><code>info.MinDecay(2)</code> is the minimum decay rate of the dynamics of tuned blocks with stability constraints. For more information about stabilized dynamics and decay rates, see the <code>MinDecay</code> option of <code>systemeOptions</code>.</p>
fSoft	<p>Individual soft constraint values, returned as a vector. <code>systeme</code> converts each soft tuning goal to a normalized value that is a function of the free parameters of the control system. The command then tunes the parameters to minimize that value subject to the hard goals. (See “Algorithms” on page 2-1359.) <code>info.fSoft</code> contains the individual values of the soft goals at the end of each run. These values appear in <code>fSoft</code> in the same order in which you specify goals in the <code>SoftReqs</code> input argument to <code>systeme</code>.</p>
gHard	<p>Individual hard constraint values, returned as a vector. <code>systeme</code> converts each hard tuning goal to a normalized value that is a function of the free parameters of the control system. The command then tunes the parameters to minimize those values. A hard goal is satisfied if its value is less than 1. (See “Algorithms” on page 2-1359.) <code>info.gHard</code> contains the individual values of the hard goals at the end of each run. These values appear in <code>gHard</code> in the same order in which you specify goals in the <code>HardReqs</code> input argument to <code>systeme</code>.</p>
Blocks	<p>Tuned values of tunable blocks and parameters in the tuned control system, returned as a structure whose fields are the names of tunable elements and whose values are the corresponding tuned values.</p> <p>When you perform multiple runs by setting the <code>RandomStart</code> option to a positive value, you can use this field to examine control system performance with the results from other runs. For instance, use the following code to apply the tuned values from the <code>j</code>th run.</p> <pre>CLj = setBlockValue(CL0,info(j).Blocks)</pre>

Field	Value
LoopScaling	<p>Optimal diagonal scaling for evaluating MIMO tuning requirements, returned as a state-space model.</p> <p>When applied to multiloop control systems, tuning goals that involve an open-loop response can be sensitive to the scaling of the loop transfer functions to which they apply. This sensitivity can lead to poor optimization results. <code>systeme</code> automatically corrects scaling issues and returns the optimal diagonal scaling matrix <code>D</code> as a state-space model in <code>info.LoopScaling</code>.</p> <p>The loop channels associated with each diagonal entry of <code>D</code> are listed in <code>info.LoopScaling.InputName</code>. The scaled loop transfer is $D \setminus L * D$, where <code>L</code> is the open-loop transfer measured at the locations <code>info.LoopScaling.InputName</code>.</p> <p>Tuning goals affected by such loop scaling include:</p> <ul style="list-style-type: none"> • <code>TuningGoal.LoopShape</code> • <code>TuningGoal.MinLoopGain</code> and <code>TuningGoal.MaxLoopGain</code> • <code>TuningGoal.Sensitivity</code> • <code>TuningGoal.Rejection</code> • <code>TuningGoal.Margins</code>

`info` also contains the following fields, whose entries are meaningful when you use `systeme` for robust tuning of control systems with uncertainty.

Field	Value
wcPert	Worst combinations of uncertain parameters, returned as a structure array. Each structure contains one set of uncertain parameter values. The perturbations with the worst performance are listed first.
wcf	Worst soft-goal value, returned as a scalar. This value is the largest soft goal value (<code>f</code>) over the uncertainty range when using the tuned controller.
wcg	Worst hard-goal value, returned as a scalar. This value is the largest hard goal value (<code>g</code>) over the uncertainty range when using the tuned controller.
wcDecay	Smallest closed-loop decay rate over the uncertainty range when using the tuned controller, returned as a scalar. A positive value indicates robust stability. For more information about stabilized dynamics and decay rates, see the <code>MinDecay</code> option of <code>systemeOptions</code> .

Algorithms

`x` is the vector of tunable parameters in the control system to tune. `systeme` converts each soft and hard tuning requirement `SoftReqs(i)` and `HardReqs(j)` into normalized values $f_i(x)$ and $g_j(x)$, respectively. `systeme` then solves the constrained minimization problem:

Minimize $\max_i f_i(x)$ subject to $\max_j g_j(x) < 1$, for $x_{\min} < x < x_{\max}$.

x_{\min} and x_{\max} are the minimum and maximum values of the free parameters of the control system.

When you use both soft and hard tuning goals, the software approaches this optimization problem by solving a sequence of unconstrained subproblems of the form:

$$\min_x \max(\alpha f(x), g(x)).$$

The software adjusts the multiplier α so that the solution of the subproblems converges to the solution of the original constrained optimization problem.

`systeme` returns the control system with parameters tuned to the values that best solve the minimization problem. `systeme` also returns the best achieved values of $f_i(x)$ and $g_j(x)$, as `fSoft` and `gHard` respectively.

For information about the functions $f_i(x)$ and $g_j(x)$ for each type of constraint, see the reference pages for each `TuningGoal` requirement object.

`systeme` uses the nonsmooth optimization algorithms described in [1],[2],[3],[4]

`systeme` computes the H_∞ norm using the algorithm of [5] and structure-preserving eigensolvers from the SLICOT library. For more information about the SLICOT library, see <http://slicot.org>.

Alternative Functionality

App

The **Control System Tuner** app provides a graphical interface to control system tuning.

Version History

Introduced in R2016a

Functionality moved from Robust Control Toolbox

Behavior changed in R2016a

Prior to R2016a, this functionality required a Robust Control Toolbox license.

References

- [1] Apkarian, P. and D. Noll, "Nonsmooth H-infinity Synthesis," *IEEE Transactions on Automatic Control*, Vol. 51, No. 1, (2006), pp. 71-86.
- [2] Apkarian, P. and D. Noll, "Nonsmooth Optimization for Multiband Frequency-Domain Control Design," *Automatica*, 43 (2007), pp. 724-731.
- [3] Apkarian, P., P. Gahinet, and C. Buhr, "Multi-model, multi-objective tuning of fixed-structure controllers," *Proceedings ECC (2014)*, pp. 856-861.
- [4] Apkarian, P., M.-N. Dao, and D. Noll, "Parametric Robust Structured Control Design," *IEEE Transactions on Automatic Control*, 2015.

[5] Bruinsma, N.A., and M. Steinbuch. "A Fast Algorithm to Compute the H_∞ Norm of a Transfer Function Matrix." *Systems & Control Letters*, 14, no.4 (April 1990): 287-93.

Extended Capabilities

Automatic Parallel Support

Accelerate code by automatically running computation in parallel using Parallel Computing Toolbox™.

To run in parallel, set 'UseParallel' to true using `systuneOptions`.

For more information, see "Speed Up Tuning with Parallel Computing Toolbox Software".

See Also

`systuneOptions` | `viewGoal` | `genss` | `sITuner` | `systune` (for `sITuner`) | `looptune` | `looptune` (for `sITuner`) | `AnalysisPoint` | `TuningGoal.Tracking` | `TuningGoal.Gain` | `TuningGoal.Margins`

Topics

"Tune Control Systems with SYSTUNE"

"Building Tunable Models"

"Programmatic Tuning"

"Generalized Models"

"Robust Tuning Approaches" (Robust Control Toolbox)

systemOptions

Set options for `system`

Syntax

```
options = systemOptions
options = systemOptions(Name,Value)
```

Description

`options = systemOptions` returns the default option set for the `system` command.

`options = systemOptions(Name,Value)` creates an option set with the options specified by one or more `Name,Value` pair arguments.

Input Arguments

Name-Value Pair Arguments

Specify optional pairs of arguments as `Name1=Value1, . . . , NameN=ValueN`, where `Name` is the argument name and `Value` is the corresponding value. Name-value arguments must appear after other arguments, but the order of the pairs does not matter.

Before R2021a, use commas to separate each name and value, and enclose Name in quotes.

`systemOptions` takes the following `Name` arguments:

Display

Amount of information to display during `system` runs.

`Display` takes the following values:

- `'final'` — Display a one-line summary at the end of each optimization run. The display includes the best achieved values for the soft and hard constraints, `fSoft` and `gHard`. The display also includes the number of iterations for each run.

Example:

```
Final: Soft = 1.09, Hard = 0.68927, Iterations = 58
```

- `'sub'` — Display the result of each optimization subproblem.

When you use both soft and hard tuning goals, the software solves the optimization as a sequence of subproblems of the form:

$$\min_x \max(\alpha f(x), g(x)).$$

Here, x is the vector of tunable parameters, $f(x)$ is the largest normalized soft-constraint value, and $g(x)$ is the largest normalized hard-constraint value. (See the “Algorithms” section of the `system` reference page for more information.) The software adjusts the multiplier α so that the

solution of the subproblems converges to the solution of the original constrained optimization problem. When you select 'sub', the report includes the results of each of these subproblems.

Example:

```
alpha=0.1: Soft = 3.97, Hard = 0.68927, Iterations = 8
alpha=0.5036: Soft = 1.36, Hard = 0.68927, Iterations = 8
alpha=1.47: Soft = 1.09, Hard = 0.68927, Iterations = 42
Final: Soft = 1.09, Hard = 0.68927, Iterations = 58
```

- 'iter' — Display optimization progress after each iteration. The display includes the value after each iteration of the objective parameter being minimized. The objective parameter is whichever is larger of $af(x)$ and $g(x)$. The display also includes a progress value that indicates the percent change in the constraints from the previous iteration.

Example:

```
Iter 1: Objective = 4.664, Progress = 93%
Iter 2: Objective = 2.265, Progress = 51.4%
Iter 3: Objective = 0.7936, Progress = 65%
Iter 4: Objective = 0.7183, Progress = 9.48%
Iter 5: Objective = 0.6893, Progress = 4.04%
Iter 6: Objective = 0.6893, Progress = 0%
Iter 7: Objective = 0.6893, Progress = 0%
Iter 8: Objective = 0.6893, Progress = 0%
alpha=0.1: Soft = 3.97, Hard = 0.68927, Iterations = 8
Iter 1: Objective = 1.146, Progress = 42.7%
Iter 2: Objective = 1.01, Progress = 11.9%
...
alpha=1.47: Soft = 1.09, Hard = 0.68927, Iterations = 42
Final: Soft = 1.09, Hard = 0.68927, Iterations = 58
```

- 'off' — Run in silent mode, displaying no information during or after the run.

Default: 'final'

MaxIter

Maximum number of iterations in each optimization run, when the run does not converge to within tolerance.

Default: 300

RandomStart

Number of additional optimizations starting from random values of the free parameters in the controller.

If `RandomStart = 0`, `systune` performs a single optimization run starting from the initial values of the tunable parameters. Setting `RandomStart = N > 0` runs N additional optimizations starting from N randomly generated parameter values.

`systune` tunes by finding a local minimum of a gain minimization problem. To increase the likelihood of finding parameter values that meet your design requirements, set `RandomStart > 0`. You can then use the best design that results from the multiple optimization runs.

Use with `UseParallel = true` to distribute independent optimization runs among MATLAB workers (requires Parallel Computing Toolbox software).

Default: 0

UseParallel

Parallel processing flag.

When you use the `RandomStart` option to run multiple randomized optimization starts, you can also use parallel computing to speed up tuning by distributing the optimization runs among workers in a parallel pool. Set this flag to `true` to enable parallel processing. If there is an available parallel pool, then the software performs independent optimization runs concurrently among workers in that pool. If no parallel pool is available, one of the following occurs:

- If **Automatically create a parallel pool** is selected in your Parallel Computing Toolbox preferences (Parallel Computing Toolbox), then the software starts a parallel pool using the settings in those preferences.
- If **Automatically create a parallel pool** is not selected in your preferences, then the software performs the optimization runs successively, without parallel processing.

If **Automatically create a parallel pool** is not selected in your preferences, you can manually start a parallel pool using `parpool` before running the tuning command.

Using parallel processing requires Parallel Computing Toolbox software.

Default: `false`

SkipModels

Models or design points to ignore, specified as an array of linear indices.

Use this option to skip specific models or ignore portions of the design space when tuning gain-scheduled control systems. For example, you might want to skip grid points outside the flight envelope of an airplane model, or points outside the operating range for tuning. Identify the models to skip by absolute index in the array of models to tune. Using `SkipModels` lets you narrow the scope of tuning without reconfiguring each tuning goal. For more information, see “Change Requirements with Operating Condition”.

Default: `[]`

SoftTarget

Target value for soft constraints.

The optimization stops when the largest soft constraint value falls below the specified `SoftTarget` value. The default value `SoftTarget = 0` minimizes the soft constraints subject to satisfying the hard constraints.

Default: 0

SoftTol

Relative tolerance for termination.

The optimization terminates when the relative decrease in the soft constraint value decreases by less than `SoftTol` over 10 consecutive iterations. Increasing `SoftTol` speeds up termination, and decreasing `SoftTol` yields tighter final values.

Default: 0.001

SoftScale

A priori estimate of best soft constraint value.

For problems that mix soft and hard constraints, providing a rough estimate of the optimal value of the soft constraints (subject to the hard constraints) helps to speed up the optimization.

Default: 1

MinDecay

Minimum decay rate for stabilized dynamics.

Most tuning goals carry an implicit closed-loop stability or minimum-phase constraint. Stabilized dynamics refers to the poles and zeros affected by these constraints. The `MinDecay` option constrains all stabilized poles and zeros to satisfy:

- $\text{Re}(s) < -\text{MinDecay}$ (continuous time).
- $\log(|z|) < -\text{MinDecay}$ (discrete time).

Adjust the minimum value if the optimization fails to meet the default value, or if the default value conflicts with other requirements. Alternatively, use `TuningGoal.Poles` to control the decay rate of a specific feedback loop.

For more information about implicit constraints for a particular tuning goal, see the reference page for that tuning goal.

Default: 1e-7

MaxRadius

Maximum spectral radius for stabilized dynamics.

This option constrains all stabilized poles and zeros to satisfy $|s| < \text{MaxRadius}$. Stabilized dynamics are those poles and zeros affected by implicit stability or minimum-phase constraints of the tuning goals. The `MaxRadius` constraint is useful to prevent these poles and zeros from going to infinity as a result of algebraic loops becoming singular or control effort growing unbounded. Adjust the maximum radius if the optimization fails to meet the default value, or if the default value conflicts with other requirements.

`MaxRadius` is ignored for discrete-time tuning, where stability constraints already impose $|z| < 1$.

For more information about implicit constraints for a particular tuning goal, see the reference page for that tuning goal.

Default: 1e8

Output Arguments

options

Option set containing the specified options for the `systune` command.

Examples

Create Options Set for systune

Create an options set for a `systune` run using five random restarts. Also, set the display level to show the progress of each iteration, and increase the relative tolerance of the soft constraint value to 0.01.

```
options = systuneOptions('RandomStart',5,'Display','iter',...  
                        'SoftTol',0.01);
```

Alternatively, use dot notation to set the values of `options`.

```
options = systuneOptions;  
options.RandomStart = 5;  
options.Display = 'iter';  
options.SoftTol = 0.01;
```

Configure Option Set for Parallel Optimization Runs

Configure an option set for a `systune` run using 20 random restarts. Execute these independent optimization runs concurrently on multiple workers in a parallel pool.

If you have the Parallel Computing Toolbox software installed, you can use parallel computing to speed up `systune` tuning of fixed-structure control systems. When you run multiple randomized `systune` optimization starts, parallel computing speeds up tuning by distributing the optimization runs among workers.

If **Automatically create a parallel pool** is not selected in your Parallel Computing Toolbox preferences (Parallel Computing Toolbox), manually start a parallel pool using `parpool`. For example:

```
parpool;
```

If **Automatically create a parallel pool** is selected in your preferences, you do not need to manually start a pool.

Create a `systuneOptions` set that specifies 20 random restarts to run in parallel.

```
options = systuneOptions('RandomStart',20,'UseParallel',true);
```

Setting `UseParallel` to `true` enables parallel processing by distributing the randomized starts among available workers in the parallel pool.

Use the `systuneOptions` set when you call `systune`. For example, suppose you have already created a tunable control system model, `CL0`. For tuning this system, you have created vectors `SoftReqs` and `HardReqs` of `TuningGoal` requirements objects. These vectors represent your soft and hard constraints, respectively. In that case, the following command uses parallel computing to tune the control system of `CL0`.

```
[CL,fSoft,gHard] = systune(CL0,SoftReqs,HardReqs,options);
```

Version History

Introduced in R2016a

Functionality moved from Robust Control Toolbox

Behavior changed in R2016a

Prior to R2016a, this functionality required a Robust Control Toolbox license.

See Also

systune | systune (for sITuner)

tf

Transfer function model

Description

Use `tf` to create real-valued or complex-valued transfer function models, or to convert dynamic system models to transfer function form.

Transfer functions are a frequency-domain representation of linear time-invariant systems. For instance, consider a continuous-time SISO dynamic system represented by the transfer function $\text{sys}(s) = N(s)/D(s)$, where $s = j\omega$ and $N(s)$ and $D(s)$ are called the numerator and denominator polynomials, respectively. The `tf` model object can represent SISO or MIMO transfer functions in continuous time or discrete time.

You can create a transfer function model object either by specifying its coefficients directly, or by converting a model of another type (such as a state-space model `ss`) to transfer-function form. For more information, see “Transfer Functions”.

You can also use `tf` to create generalized state-space (`gens`) models or uncertain state-space (`uss`) models.

Creation

Syntax

```
sys = tf(numerator,denominator)
sys = tf(numerator,denominator,ts)
sys = tf(numerator,denominator,ltiSys)

sys = tf(m)

sys = tf(___,Name,Value)

sys = tf(ltiSys)
sys = tf(ltiSys,component)

s = tf('s')
z = tf('z',ts)
```

Description

`sys = tf(numerator,denominator)` creates a continuous-time transfer function model, setting the `Numerator` and `Denominator` properties. For instance, consider a continuous-time SISO dynamic system represented by the transfer function $\text{sys}(s) = N(s)/D(s)$, the input arguments `numerator` and `denominator` are the coefficients of $N(s)$ and $D(s)$, respectively.

`sys = tf(numerator,denominator,ts)` creates a discrete-time transfer function model, setting the `Numerator`, `Denominator`, and `Ts` properties. For instance, consider a discrete-time SISO

dynamic system represented by the transfer function $\text{sys}(z) = N(z)/D(z)$, the input arguments `numerator` and `denominator` are the coefficients of $N(z)$ and $D(z)$, respectively. To leave the sample time unspecified, set `ts` input argument to `-1`.

`sys = tf(numerator,denominator,ltiSys)` creates a transfer function model with properties inherited from the dynamic system model `ltiSys`, including the sample time.

`sys = tf(m)` creates a transfer function model that represents the static gain, `m`.

`sys = tf(____,Name,Value)` sets properties of the transfer function model using one or more `Name,Value` pair arguments for any of the previous input-argument combinations.

`sys = tf(ltiSys)` converts the dynamic system model `ltiSys` to a transfer function model.

`sys = tf(ltiSys,component)` converts the specified component of `ltiSys` to transfer function form. Use this syntax only when `ltiSys` is an identified linear time-invariant (LTI) model.

`s = tf('s')` creates special variable `s` that you can use in a rational expression to create a continuous-time transfer function model. Using a rational expression can sometimes be easier and more intuitive than specifying polynomial coefficients.

`z = tf('z',ts)` creates special variable `z` that you can use in a rational expression to create a discrete-time transfer function model. To leave the sample time unspecified, set `ts` input argument to `-1`.

Input Arguments

numerator — Numerator coefficients of the transfer function

row vector | Ny-by-Nu cell array of row vectors

Numerator coefficients of the transfer function, specified as:

- A row vector of polynomial coefficients.
- An Ny-by-Nu cell array of row vectors to specify a MIMO transfer function, where Ny is the number of outputs, and Nu is the number of inputs.

When you create the transfer function, specify the numerator coefficients in order of descending power. For instance, if the transfer function numerator is $3s^2 - 4s + 5$, then specify `numerator` as `[3 -4 5]`. For a discrete-time transfer function with numerator $2z - 1$, set `numerator` to `[2 -1]`.

Also a property of the `tf` object. For more information, see `Numerator`.

denominator — Denominator coefficients of the transfer function

row vector | Ny-by-Nu cell array of row vectors

Denominator coefficients, specified as:

- A row vector of polynomial coefficients.
- An Ny-by-Nu cell array of row vectors to specify a MIMO transfer function, where Ny is the number of outputs and Nu is the number of inputs.

When you create the transfer function, specify the denominator coefficients in order of descending power. For instance, if the transfer function denominator is $7s^2 + 8s - 9$, then specify `denominator` as `[7 8 -9]`. For a discrete-time transfer function with denominator $2z^2 + 1$, set `denominator` to `[2 0 1]`.

Also a property of the `tf` object. For more information, see Denominator.

ts — Sample time

scalar

Sample time, specified as a scalar. Also a property of the `tf` object. For more information, see `Ts`.

ltiSys — Dynamic system

dynamic system model | model array

Dynamic system, specified as a SISO or MIMO dynamic system model or array of dynamic system models. Dynamic systems that you can use include:

- Continuous-time or discrete-time numeric LTI models, such as `tf`, `zpk`, `ss`, or `pid` models.
- Generalized or uncertain LTI models such as `genss` or `uss` models. (Using uncertain models requires Robust Control Toolbox software.)

The resulting transfer function assumes

- current values of the tunable components for tunable control design blocks.
- nominal model values for uncertain control design blocks.
- Identified LTI models, such as `idtf`, `idss`, `idproc`, `idpoly`, and `idgrey` models. To select the component of the identified model to convert, specify `component`. If you do not specify `component`, `tf` converts the measured component of the identified model by default. (Using identified models requires System Identification Toolbox software.)

m — Static gain

scalar | matrix

Static gain, specified as a scalar or matrix. Static gain or steady state gain of a system represents the ratio of the output to the input under steady state condition.

component — Component of identified model

'measured' (default) | 'noise' | 'augmented'

Component of identified model to convert, specified as one of the following:

- 'measured' — Convert the measured component of `sys`.
- 'noise' — Convert the noise component of `sys`
- 'augmented' — Convert both the measured and noise components of `sys`.

`component` only applies when `sys` is an identified LTI model.

For more information on identified LTI models and their measured and noise components, see "Identified LTI Models".

Output Arguments**sys — Output system model**

`tf` model object | `genss` model object | `uss` model object

Output system model, returned as:

- A transfer function (`tf`) model object, when `numerator` and `denominator` input arguments are numeric arrays.
- A generalized state-space model (`genss`) object, when the `numerator` or `denominator` input arguments includes tunable parameters, such as `realp` parameters or generalized matrices (`genmat`). For an example, see “Tunable Low-Pass Filter” on page 2-1387.
- An uncertain state-space model (`uss`) object, when the `numerator` or `denominator` input arguments includes uncertain parameters. Using uncertain models requires Robust Control Toolbox software. For an example, see “Transfer Function with Uncertain Coefficients” (Robust Control Toolbox).

Properties

Numerator — Numerator coefficients

row vector | Ny-by-Nu cell array of row vectors

Numerator coefficients, specified as:

- A row vector of polynomial coefficients in order of descending power (for `Variable` values `'s'`, `'z'`, `'p'`, or `'q'`) or in order of ascending power (for `Variable` values `'z^-1'` or `'q^-1'`).
- An Ny-by-Nu cell array of row vectors to specify a MIMO transfer function, where Ny is the number of outputs and Nu is the number of inputs. Each element of the cell array specifies the numerator coefficients for a given input/output pair. If you specify both `Numerator` and `Denominator` as cell arrays, they must have the same dimensions.

The coefficients of `Numerator` can be either real-valued or complex-valued.

Denominator — Denominator coefficients

row vector | Ny-by-Nu cell array of row vectors

Denominator coefficients, specified as:

- A row vector of polynomial coefficients in order of descending power (for values `Variable` values `'s'`, `'z'`, `'p'`, or `'q'`) or in order of ascending power (for `Variable` values `'z^-1'` or `'q^-1'`).
- An Ny-by-Nu cell array of row vectors to specify a MIMO transfer function, where Ny is the number of outputs and Nu is the number of inputs. Each element of the cell array specifies the numerator coefficients for a given input/ output pair. If you specify both `Numerator` and `Denominator` as cell arrays, they must have the same dimensions.

If all SISO entries of a MIMO transfer function have the same denominator, you can specify `Denominator` as the row vector while specifying `Numerator` as a cell array.

The coefficients of `Denominator` can be either real-valued or complex-valued.

Variable — Transfer function display variable

`'s'` (default) | `'z'` | `'p'` | `'q'` | `'z^-1'` | `'q^-1'`

Transfer function display variable, specified as one of the following:

- `'s'` — Default for continuous-time models
- `'z'` — Default for discrete-time models
- `'p'` — Equivalent to `'s'`

- 'q' — Equivalent to 'z'
- 'z^-1' — Inverse of 'z'
- 'q^-1' — Equivalent to 'z^-1'

The value of `Variable` is reflected in the display, and also affects the interpretation of the `Numerator` and `Denominator` coefficient vectors for discrete-time models.

- For `Variable` values 's', 'z', 'p', or 'q', the coefficients are ordered in descending powers of the variable. For example, consider the row vector $[a_k \dots a_1 a_0]$. The polynomial order is specified as $a_k z^k + \dots + a_1 z + a_0$.
- For `Variable` values 'z^-1' or 'q^-1', the coefficients are ordered in ascending powers of the variable. For example, consider the row vector $[b_0 b_1 \dots b_k]$. The polynomial order is specified as $b_0 + b_1 z^{-1} + \dots + b_k z^{-k}$.

For examples, see “Specify Polynomial Ordering in Discrete-Time Transfer Function” on page 2-1386, “Transfer Function Model Using Rational Expression” on page 2-1381, and “Discrete-Time Transfer Function Model Using Rational Expression” on page 2-1382.

IODelay — Transport delay

0 (default) | scalar | Ny-by-Nu array

Transport delay, specified as one of the following:

- Scalar — Specify the transport delay for a SISO system or the same transport delay for all input/output pairs of a MIMO system.
- Ny-by-Nu array — Specify separate transport delays for each input/output pair of a MIMO system. Here, Ny is the number of outputs and Nu is the number of inputs.

For continuous-time systems, specify transport delays in the time unit specified by the `TimeUnit` property. For discrete-time systems, specify transport delays in integer multiples of the sample time, `Ts`.

InputDelay — Input delay

0 (default) | scalar | Nu-by-1 vector

Input delay for each input channel, specified as one of the following:

- Scalar — Specify the input delay for a SISO system or the same delay for all inputs of a multi-input system.
- Nu-by-1 vector — Specify separate input delays for input of a multi-input system, where Nu is the number of inputs.

For continuous-time systems, specify input delays in the time unit specified by the `TimeUnit` property. For discrete-time systems, specify input delays in integer multiples of the sample time, `Ts`.

For more information, see “Time Delays in Linear Systems”.

OutputDelay — Output delay

0 (default) | scalar | Ny-by-1 vector

Output delay for each output channel, specified as one of the following:

- **Scalar** — Specify the output delay for a SISO system or the same delay for all outputs of a multi-output system.
- **Ny-by-1 vector** — Specify separate output delays for output of a multi-output system, where Ny is the number of outputs.

For continuous-time systems, specify output delays in the time unit specified by the `TimeUnit` property. For discrete-time systems, specify output delays in integer multiples of the sample time, `Ts`.

For more information, see “Time Delays in Linear Systems”.

Ts — Sample time

0 (default) | positive scalar | -1

Sample time, specified as:

- 0 for continuous-time systems.
- A positive scalar representing the sampling period of a discrete-time system. Specify `Ts` in the time unit specified by the `TimeUnit` property.
- -1 for a discrete-time system with an unspecified sample time.

Note Changing `Ts` does not discretize or resample the model. To convert between continuous-time and discrete-time representations, use `c2d` and `d2c`. To change the sample time of a discrete-time system, use `d2d`.

TimeUnit — Time variable units

'seconds' (default) | 'nanoseconds' | 'microseconds' | 'milliseconds' | 'minutes' | 'hours' | 'days' | 'weeks' | 'months' | 'years' | ...

Time variable units, specified as one of the following:

- 'nanoseconds'
- 'microseconds'
- 'milliseconds'
- 'seconds'
- 'minutes'
- 'hours'
- 'days'
- 'weeks'
- 'months'
- 'years'

Changing `TimeUnit` has no effect on other properties, but changes the overall system behavior. Use `chgTimeUnit` to convert between time units without modifying system behavior.

InputName — Input channel names

' ' (default) | character vector | cell array of character vectors

Input channel names, specified as one of the following:

- A character vector, for single-input models.
- A cell array of character vectors, for multi-input models.
- `''`, no names specified, for any input channels.

Alternatively, you can assign input names for multi-input models using automatic vector expansion. For example, if `sys` is a two-input model, enter the following:

```
sys.InputName = 'controls';
```

The input names automatically expand to `{'controls(1)'; 'controls(2)'}`.

You can use the shorthand notation `u` to refer to the `InputName` property. For example, `sys.u` is equivalent to `sys.InputName`.

Use `InputName` to:

- Identify channels on model display and plots.
- Extract subsystems of MIMO systems.
- Specify connection points when interconnecting models.

InputUnit — Input channel units

`''` (default) | character vector | cell array of character vectors

Input channel units, specified as one of the following:

- A character vector, for single-input models.
- A cell array of character vectors, for multi-input models.
- `''`, no units specified, for any input channels.

Use `InputUnit` to specify input signal units. `InputUnit` has no effect on system behavior.

InputGroup — Input channel groups

structure

Input channel groups, specified as a structure. Use `InputGroup` to assign the input channels of MIMO systems into groups and refer to each group by name. The field names of `InputGroup` are the group names and the field values are the input channels of each group. For example, enter the following to create input groups named `controls` and `noise` that include input channels 1 and 2, and 3 and 5, respectively.

```
sys.InputGroup.controls = [1 2];  
sys.InputGroup.noise = [3 5];
```

You can then extract the subsystem from the `controls` inputs to all outputs using the following.

```
sys(:, 'controls')
```

By default, `InputGroup` is a structure with no fields.

OutputName — Output channel names

`''` (default) | character vector | cell array of character vectors

Output channel names, specified as one of the following:

- A character vector, for single-output models.
- A cell array of character vectors, for multi-output models.
- `''`, no names specified, for any output channels.

Alternatively, you can assign output names for multi-output models using automatic vector expansion. For example, if `sys` is a two-output model, enter the following.

```
sys.OutputName = 'measurements';
```

The output names automatically expand to `{'measurements(1)'; 'measurements(2)'}`.

You can also use the shorthand notation `y` to refer to the `OutputName` property. For example, `sys.y` is equivalent to `sys.OutputName`.

Use `OutputName` to:

- Identify channels on model display and plots.
- Extract subsystems of MIMO systems.
- Specify connection points when interconnecting models.

OutputUnit – Output channel units

`''` (default) | character vector | cell array of character vectors

Output channel units, specified as one of the following:

- A character vector, for single-output models.
- A cell array of character vectors, for multi-output models.
- `''`, no units specified, for any output channels.

Use `OutputUnit` to specify output signal units. `OutputUnit` has no effect on system behavior.

OutputGroup – Output channel groups

structure

Output channel groups, specified as a structure. Use `OutputGroup` to assign the output channels of MIMO systems into groups and refer to each group by name. The field names of `OutputGroup` are the group names and the field values are the output channels of each group. For example, create output groups named `temperature` and `measurement` that include output channels 1, and 3 and 5, respectively.

```
sys.OutputGroup.temperature = [1];
sys.OutputGroup.measurement = [3 5];
```

You can then extract the subsystem from all inputs to the `measurement` outputs using the following.

```
sys('measurement', :)
```

By default, `OutputGroup` is a structure with no fields.

Name – System name

`''` (default) | character vector

System name, specified as a character vector. For example, `'system_1'`.

Notes — User-specified text

{ } (default) | character vector | cell array of character vectors

User-specified text that you want to associate with the system, specified as a character vector or cell array of character vectors. For example, 'System is MIMO'.

UserData — User-specified data

[] (default) | any MATLAB data type

User-specified data that you want to associate with the system, specified as any MATLAB data type.

SamplingGrid — Sampling grid for model arrays

structure array

Sampling grid for model arrays, specified as a structure array.

Use `SamplingGrid` to track the variable values associated with each model in a model array, including identified linear time-invariant (IDLTI) model arrays.

Set the field names of the structure to the names of the sampling variables. Set the field values to the sampled variable values associated with each model in the array. All sampling variables must be numeric scalars, and all arrays of sampled values must match the dimensions of the model array.

For example, you can create an 11-by-1 array of linear models, `sysarr`, by taking snapshots of a linear time-varying system at times `t = 0:10`. The following code stores the time samples with the linear models.

```
sysarr.SamplingGrid = struct('time',0:10)
```

Similarly, you can create a 6-by-9 model array, `M`, by independently sampling two variables, `zeta` and `w`. The following code maps the (`zeta,w`) values to `M`.

```
[zeta,w] = ndgrid(<6 values of zeta>,<9 values of w>)
M.SamplingGrid = struct('zeta',zeta,'w',w)
```

When you display `M`, each entry in the array includes the corresponding `zeta` and `w` values.

`M`

```
M(:,:,1,1) [zeta=0.3, w=5] =
```

```
      25
-----
s^2 + 3 s + 25
```

```
M(:,:,2,1) [zeta=0.35, w=5] =
```

```
      25
-----
s^2 + 3.5 s + 25
```

...

For model arrays generated by linearizing a Simulink model at multiple parameter values or operating points, the software populates `SamplingGrid` automatically with the variable values that

correspond to each entry in the array. For instance, the Simulink Control Design commands `linearize` and `sLinearizer` populate `SamplingGrid` automatically.

By default, `SamplingGrid` is a structure with no fields.

Object Functions

The following lists contain a representative subset of the functions you can use with `tf` models. In general, any function applicable to “Dynamic System Models” is applicable to a `tf` object.

Linear Analysis

<code>step</code>	Step response plot of dynamic system; step response data
<code>impulse</code>	Impulse response plot of dynamic system; impulse response data
<code>lsim</code>	Plot simulated time response of dynamic system to arbitrary inputs; simulated response data
<code>bode</code>	Bode plot of frequency response, or magnitude and phase data
<code>nyquist</code>	Nyquist plot of frequency response
<code>nichols</code>	Nichols chart of frequency response
<code>bandwidth</code>	Frequency response bandwidth

Stability Analysis

<code>pole</code>	Poles of dynamic system
<code>zero</code>	Zeros and gain of SISO dynamic system
<code>pzplot</code>	Pole-zero plot of dynamic system model with additional plot customization options
<code>margin</code>	Gain margin, phase margin, and crossover frequencies

Model Transformation

<code>zpk</code>	Zero-pole-gain model
<code>ss</code>	State-space model
<code>c2d</code>	Convert model from continuous to discrete time
<code>d2c</code>	Convert model from discrete to continuous time
<code>d2d</code>	Resample discrete-time model

Model Interconnection

<code>feedback</code>	Feedback connection of multiple models
<code>connect</code>	Block diagram interconnections of dynamic systems
<code>series</code>	Series connection of two models
<code>parallel</code>	Parallel connection of two models

Controller Design

<code>piddtune</code>	PID tuning algorithm for linear plant model
<code>rlocus</code>	Root locus plot of dynamic system
<code>lqr</code>	Linear-Quadratic Regulator (LQR) design
<code>lqg</code>	Linear-Quadratic-Gaussian (LQG) design
<code>lqi</code>	Linear-Quadratic-Integral control
<code>kalman</code>	Design Kalman filter for state estimation

Examples

SISO Transfer Function Model

For this example, consider the following SISO transfer function model:

$$\text{sys}(s) = \frac{1}{2s^2 + 3s + 4}.$$

Specify the numerator and denominator coefficients ordered in descending powers of s , and create the transfer function model.

```
numerator = 1;
denominator = [2,3,4];
sys = tf(numerator,denominator)
```

```
sys =
```

$$\frac{1}{2 s^2 + 3 s + 4}$$

Continuous-time transfer function.

Discrete-Time SISO Transfer Function Model

For this example, consider the following discrete-time SISO transfer function model:

$$\text{sys}(z) = \frac{2z}{4z^3 + 3z - 1}.$$

Specify the numerator and denominator coefficients ordered in descending powers of z and the sample time of 0.1 seconds. Create the discrete-time transfer function model.

```
numerator = [2,0];
denominator = [4,0,3,-1];
ts = 0.1;
sys = tf(numerator,denominator,ts)
```

```
sys =
```

$$\frac{2 z}{4 z^3 + 3 z - 1}$$

Sample time: 0.1 seconds
Discrete-time transfer function.

Second-Order Transfer Function from Damping Ratio and Natural Frequency

For this example, consider a transfer function model that represents a second-order system with known natural frequency and damping ratio.

The transfer function of a second-order system, expressed in terms of its damping ratio ζ and natural frequency ω_0 , is:

$$\text{sys}(s) = \frac{\omega_0^2}{s^2 + 2\zeta\omega_0 s + \omega_0^2}.$$

Assuming a damping ratio, $\zeta = 0.25$ and natural frequency, $\omega_0 = 3$ rad/s, create the second order transfer function.

```
zeta = 0.25;  
w0 = 3;  
numerator = w0^2;  
denominator = [1,2*zeta*w0,w0^2];  
sys = tf(numerator,denominator)
```

```
sys =
```

$$\frac{9}{s^2 + 1.5 s + 9}$$

Continuous-time transfer function.

Examine the response of this transfer function to a step input.

```
stepplot(sys)
```

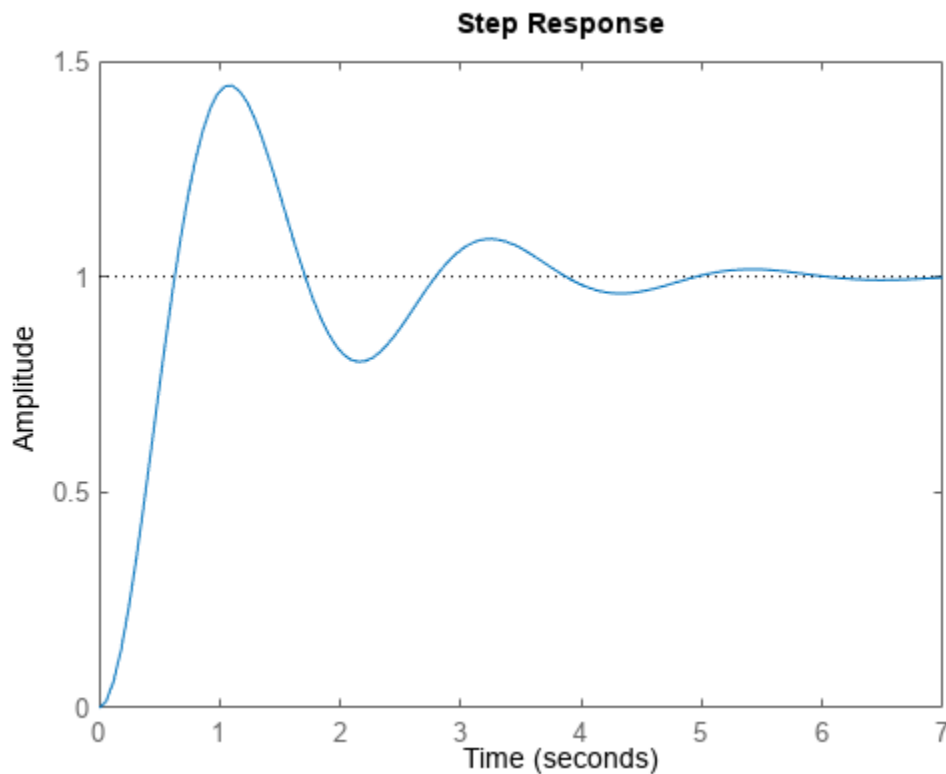

The plot shows the ringdown expected of a second-order system with a low damping ratio.

Discrete-Time MIMO Transfer Function Model

Create a transfer function for the discrete-time, multi-input, multi-output model:

$$\text{sys}(z) = \begin{bmatrix} \frac{1}{z+0.3} & \frac{z}{z+0.3} \\ \frac{-z+2}{z+0.3} & \frac{3}{z+0.3} \end{bmatrix}$$

with sample time `ts = 0.2` seconds.

Specify the numerator coefficients as a 2-by-2 matrix.

```
numerators = {1 [1 0];[-1 2] 3};
```

Specify the coefficients of the common denominator as a row vector.

```
denominator = [1 0.3];
```

Create the discrete-time MIMO transfer function model.

```
ts = 0.2;
sys = tf(numerators,denominator,ts)
```

```
sys =
```

```
From input 1 to output...
```

```
      1
1:  -----
    z + 0.3
```

```
    -z + 2
2:  -----
    z + 0.3
```

```
From input 2 to output...
```

```
      z
1:  -----
    z + 0.3
```

```
      3
2:  -----
    z + 0.3
```

```
Sample time: 0.2 seconds
Discrete-time transfer function.
```

For more information on creating MIMO transfer functions, see “MIMO Transfer Functions”.

Concatenate SISO Transfer Functions into MIMO Transfer Function Model

In this example, you create a MIMO transfer function model by concatenating SISO transfer function models. Consider the following single-input, two-output transfer function:

$$\text{sys}(s) = \begin{bmatrix} \frac{s-1}{s+1} \\ \frac{s+2}{s^2+4s+5} \end{bmatrix}.$$

Specify the MIMO transfer function model by concatenating the SISO entries.

```
sys1 = tf([1 -1],[1 1]);
sys2 = tf([1 2],[1 4 5]);
sys = [sys1;sys2]
```

```
sys =
```

```
From input to output...
      s - 1
1:  -----
      s + 1

           s + 2
2:  -----
      s^2 + 4 s + 5
```

Continuous-time transfer function.

For more information on creating MIMO transfer functions, see “MIMO Transfer Functions”.

Transfer Function Model Using Rational Expression

For this example, create a continuous-time transfer function model using rational expressions. Using a rational expression can sometimes be easier and more intuitive than specifying polynomial coefficients of the numerator and denominator.

Consider the following system:

$$\text{sys}(s) = \frac{s}{s^2 + 2s + 10}.$$

To create the transfer function model, first specify s as a `tf` object.

```
s = tf('s')
```

```
s =
```

```
s
```

Continuous-time transfer function.

Create the transfer function model using s in the rational expression.

```
sys = s/(s^2 + 2*s + 10)
```

```
sys =
```

$$\frac{s}{s^2 + 2s + 10}$$

```
Continuous-time transfer function.
```

Discrete-Time Transfer Function Model Using Rational Expression

For this example, create a discrete-time transfer function model using a rational expression. Using a rational expression can sometimes be easier and more intuitive than specifying polynomial coefficients.

Consider the following system:

$$\text{sys}(z) = \frac{z - 1}{z^2 - 1.85z + 0.9}$$

To create the transfer function model, first specify z as a `tf` object and the sample time T_s .

```
ts = 0.1;
z = tf('z',ts)
```

```
z =
```

```
z
```

```
Sample time: 0.1 seconds
Discrete-time transfer function.
```

Create the transfer function model using z in the rational expression.

```
sys = (z - 1) / (z^2 - 1.85*z + 0.9)
```

```
sys =
```

$$\frac{z - 1}{z^2 - 1.85z + 0.9}$$

```
Sample time: 0.1 seconds
Discrete-time transfer function.
```

Transfer Function Model with Inherited Properties

For this example, create a transfer function model with properties inherited from another transfer function model. Consider the following two transfer functions:

$$\text{sys1}(s) = \frac{2s}{s^2 + 8s} \quad \text{and} \quad \text{sys2}(s) = \frac{s - 1}{7s^4 + 2s^3 + 9}$$

For this example, create `sys1` with the `TimeUnit` and `InputDelay` property set to 'minutes'.

```
numerator1 = [2,0];
denominator1 = [1,8,0];
sys1 = tf(numerator1,denominator1,'TimeUnit','minutes','InputUnit','minutes')
```

```
sys1 =
```

$$\frac{2 s}{s^2 + 8 s}$$

Continuous-time transfer function.

```
propValues1 = [sys1.TimeUnit,sys1.InputUnit]
```

```
propValues1 = 1x2 cell
    {'minutes'}    {'minutes'}
```

Create the second transfer function model with properties inherited from `sys1`.

```
numerator2 = [1,-1];
denominator2 = [7,2,0,0,9];
sys2 = tf(numerator2,denominator2,sys1)
```

```
sys2 =
```

$$\frac{s - 1}{7 s^4 + 2 s^3 + 9}$$

Continuous-time transfer function.

```
propValues2 = [sys2.TimeUnit,sys2.InputUnit]
```

```
propValues2 = 1x2 cell
    {'minutes'}    {'minutes'}
```

Observe that the transfer function model `sys2` has that same properties as `sys1`.

Array of Transfer Function Models

You can use a `for` loop to specify an array of transfer function models.

First, pre-allocate the transfer function array with zeros.

```
sys = tf(zeros(1,1,3));
```

The first two indices represent the number of outputs and inputs for the models, while the third index is the number of models in the array.

Create the transfer function model array using a rational expression in the `for` loop.

```
s = tf('s');
for k = 1:3
```

```

    sys(:,:,k) = k/(s^2+s+k);
end
sys

```

```

sys(:,:,1,1) =

```

$$\frac{1}{s^2 + s + 1}$$

```

sys(:,:,2,1) =

```

$$\frac{2}{s^2 + s + 2}$$

```

sys(:,:,3,1) =

```

$$\frac{3}{s^2 + s + 3}$$

3x1 array of continuous-time transfer functions.

Convert State-Space Model to Transfer Function

For this example, compute the transfer function of the following state-space model:

$$A = \begin{bmatrix} -2 & -1 \\ 1 & -2 \end{bmatrix}, \quad B = \begin{bmatrix} 1 & 1 \\ 2 & -1 \end{bmatrix}, \quad C = [1 \ 0], \quad D = [0 \ 1].$$

Create the state-space model using the state-space matrices.

```

A = [-2 -1;1 -2];
B = [1 1;2 -1];
C = [1 0];
D = [0 1];
ltiSys = ss(A,B,C,D);

```

Convert the state-space model `ltiSys` to a transfer function.

```

sys = tf(ltiSys)

```

```

sys =

```

```

    From input 1 to output:

```

$$\frac{s}{s^2 + 4s + 5}$$

```

    From input 2 to output:

```

$$\frac{s^2 + 5s + 8}{s^2 + 4s + 5}$$

$$s^2 + 4s + 5$$

Continuous-time transfer function.

Extract Transfer Functions from Identified Model

For this example, extract the measured and noise components of an identified polynomial model into two separate transfer functions.

Load the Box-Jenkins polynomial model `ltiSys` in `identifiedModel.mat`.

```
load('identifiedModel.mat','ltiSys');
```

`ltiSys` is an identified discrete-time model of the form: $y(t) = \frac{B}{F}u(t) + \frac{C}{D}e(t)$, where $\frac{B}{F}$ represents the measured component and $\frac{C}{D}$ the noise component.

Extract the measured and noise components as transfer functions.

```
sysMeas = tf(ltiSys,'measured')
```

```
sysMeas =
```

```
From input "u1" to output "y1":
      -0.1426 z^-1 + 0.1958 z^-2
z^(-2) * -----
      1 - 1.575 z^-1 + 0.6115 z^-2
```

Sample time: 0.04 seconds
Discrete-time transfer function.

```
sysNoise = tf(ltiSys,'noise')
```

```
sysNoise =
```

```
From input "v@y1" to output "y1":
      0.04556 + 0.03301 z^-1
-----
      1 - 1.026 z^-1 + 0.26 z^-2 - 0.1949 z^-3
```

Input groups:

Name	Channels
Noise	1

Sample time: 0.04 seconds
Discrete-time transfer function.

The measured component can serve as a plant model, while the noise component can be used as a disturbance model for control system design.

Specify Input and Output Names for MIMO Transfer Function Model

Transfer function model objects include model data that helps you keep track of what the model represents. For instance, you can assign names to the inputs and outputs of your model.

Consider the following continuous-time MIMO transfer function model:

$$\text{sys}(s) = \begin{bmatrix} \frac{s+1}{s^2+2s+2} \\ \frac{1}{s} \end{bmatrix}$$

The model has one input – Current, and two outputs – Torque and Angular velocity.

First, specify the numerator and denominator coefficients of the model.

```
numerators = {[1 1] ; 1};
denominators = {[1 2 2] ; [1 0]};
```

Create the transfer function model, specifying the input name and output names.

```
sys = tf(numerators,denominators,'InputName','Current',...
        'OutputName',{'Torque' 'Angular Velocity'})
```

```
sys =
```

```
From input "Current" to output...
```

```
      s + 1
Torque:  -----
      s^2 + 2 s + 2
```

```
      1
Angular Velocity:  -
                  s
```

```
Continuous-time transfer function.
```

Specify Polynomial Ordering in Discrete-Time Transfer Function

For this example, specify polynomial ordering in discrete-time transfer function models using the 'Variable' property.

Consider the following discrete-time transfer functions with sample time 0.1 seconds:

$$\text{sys1}(z) = \frac{z^2}{z^2 + 2z + 3} \quad \text{sys2}(z^{-1}) = \frac{1}{1 + 2z^{-1} + 3z^{-2}}$$

Create the first discrete-time transfer function by specifying the z coefficients.

```
numerator = [1,0,0];
denominator = [1,2,3];
ts = 0.1;
sys1 = tf(numerator,denominator,ts)
```

```
sys1 =
```

$$\frac{z^2}{z^2 + 2z + 3}$$

```
Sample time: 0.1 seconds
Discrete-time transfer function.
```

The coefficients of `sys1` are ordered in descending powers of z .

`tf` switches convention based on the value of the 'Variable' property. Since `sys2` is the inverse transfer function model of `sys1`, specify 'Variable' as 'z^-1' and use the same numerator and denominator coefficients.

```
sys2 = tf(numerator,denominator,ts,'Variable','z^-1')
```

```
sys2 =
```

$$\frac{1}{1 + 2z^{-1} + 3z^{-2}}$$

```
Sample time: 0.1 seconds
Discrete-time transfer function.
```

The coefficients of `sys2` are now ordered in ascending powers of z^{-1} .

Based on different conventions, you can specify polynomial ordering in transfer function models using the 'Variable' property.

Tunable Low-Pass Filter

In this example, you will create a low-pass filter with one tunable parameter a :

$$F = \frac{a}{s + a}$$

Since the numerator and denominator coefficients of a `tunableTF` block are independent, you cannot use `tunableTF` to represent F . Instead, construct F using the tunable real parameter object `realp`.

Create a real tunable parameter with an initial value of 10.

```
a = realp('a',10)
```

```
a =
    Name: 'a'
    Value: 10
    Minimum: -Inf
    Maximum: Inf
    Free: 1
```

Real scalar parameter.

Use `tf` to create the tunable low-pass filter F .

```

numerator = a;
denominator = [1,a];
F = tf(numerator,denominator)

```

```
F =
```

```

Generalized continuous-time state-space model with 1 outputs, 1 inputs, 1 states, and the following
a: Scalar parameter, 2 occurrences.

```

Type "ss(F)" to see the current value, "get(F)" to see all properties, and "F.Blocks" to interact

F is a `genss` object which has the tunable parameter `a` in its `Blocks` property. You can connect F with other tunable or numeric models to create more complex control system models. For an example, see "Control System with Tunable Components".

Static Gain MIMO Transfer Function Model

In this example, you will create a static gain MIMO transfer function model.

Consider the following two-input, two-output static gain matrix `m`:

$$m = \begin{bmatrix} 2 & 4 \\ 3 & 5 \end{bmatrix}$$

Specify the gain matrix and create the static gain transfer function model.

```

m = [2,4;...
     3,5];
sys1 = tf(m)

```

```
sys1 =
```

```
From input 1 to output...
```

```
1: 2
```

```
2: 3
```

```
From input 2 to output...
```

```
1: 4
```

```
2: 5
```

```
Static gain.
```

You can use static gain transfer function model `sys1` obtained above to cascade it with another transfer function model.

For this example, create another two-input, two-output discrete transfer function model and use the `series` function to connect the two models.

```

numerators = {1,[1,0];[-1,2],3};
denominator = [1,0.3];
ts = 0.2;
sys2 = tf(numerators,denominator,ts)

```

```

sys2 =

From input 1 to output...
      1
1:  -----
   z + 0.3

      -z + 2
2:  -----
   z + 0.3

From input 2 to output...
      z
1:  -----
   z + 0.3

      3
2:  -----
   z + 0.3

Sample time: 0.2 seconds
Discrete-time transfer function.

```

```
sys = series(sys1,sys2)
```

```

sys =

From input 1 to output...
 3 z^2 + 2.9 z + 0.6
1:  -----
  z^2 + 0.6 z + 0.09

 -2 z^2 + 12.4 z + 3.9
2:  -----
  z^2 + 0.6 z + 0.09

From input 2 to output...
 5 z^2 + 5.5 z + 1.2
1:  -----
  z^2 + 0.6 z + 0.09

 -4 z^2 + 21.8 z + 6.9
2:  -----
  z^2 + 0.6 z + 0.09

```

```

Sample time: 0.2 seconds
Discrete-time transfer function.

```

Limitations

- Transfer function models are ill-suited for numerical computations. Once created, convert them to state-space form before combining them with other models or performing model transformations. You can then convert the resulting models back to transfer function form for inspection purposes
- An identified nonlinear model cannot be directly converted into a transfer function model using `tf`. To obtain a transfer function model:

- 1 Convert the nonlinear identified model to an identified LTI model using `linapp`, `idnlarx/linearize`, or `idnlhw/linearize`.
- 2 Then, convert the resulting model to a transfer function model using `tf`.

Version History

Introduced before R2006a

See Also

`filt` | `frd` | `get` | `set` | `ss` | `tfdata` | `zpk` | `genss` | `realp` | `genmat` | `tunableTF`

Topics

“What Are Model Objects?”

“Transfer Functions”

“Discrete-Time Numeric Models”

“MIMO Transfer Functions”

“Using the Right Model Representation”

“Using FEEDBACK to Close Feedback Loops”

External Websites

Transfer Function Analysis of Dynamic Systems (MathWorks Teaching Resources)

tfdata

Access transfer function data

Syntax

```
[num,den] = tfdata(sys)
[num,den,ts] = tfdata(sys)
[num,den,ts,sdnum,sdden] = tfdata(sys)
___ = tfdata(sys,J1,...,JN)
[num,den] = tfdata(sys,'v')
```

Description

`[num,den] = tfdata(sys)` returns the numerator and denominator coefficients of the transfer function for the `tf`, `ss` and `zpk` model objects or the array of model objects represented by `sys`.

The outputs `num` and `den` are two-dimensional cell arrays if `sys` contains a single LTI model. When `sys` is an array of models, `num` and `den` are returned as multidimensional cell arrays.

`[num,den,ts] = tfdata(sys)` also returns the sample time `ts`.

`[num,den,ts,sdnum,sdden] = tfdata(sys)` also returns the uncertainties in the numerator and denominator coefficients of identified system `sys`. `sdnum{i,j}(k)` is the 1 standard uncertainty in the value `num{i,j}(k)` and `sdden{i,j}(k)` is the 1 standard uncertainty in the value `den{i,j}(k)`. If `sys` does not contain uncertainty information, `sdnum` and `sdden` are empty `[]`.

`___ = tfdata(sys,J1,...,JN)` extracts the data for the `J1,...,JN` entry in the model array `sys`.

`[num,den] = tfdata(sys,'v')` returns the numerator and denominator coefficients as row vectors rather than cell arrays for a SISO transfer function represented by `sys`.

Examples

Extract Numerator and Denominator Coefficients from Transfer Function

For this example, consider `tfData.mat` which contains a continuous-time SISO transfer function `sys1`.

Load the data and use `tfdata` to extract the numerator and denominator coefficients.

```
load('tfData.mat','sys1');
[num,den] = tfdata(sys1);
```

`num` and `den` are returned as cell arrays. To display data, use `celldisp`.

```
celldisp(num)
```

```
num{1} =
```

```
0 1 5 2
```

```
celldisp(den)
```

```
den{1} =
```

```
7 4 2 1
```

You can also extract the numerator and denominator coefficients as row vectors with the following syntax.

```
[num,den] = tfdata(sys1,'v');
```

Extract Discrete-Time Transfer Function Data

For this example, consider `tfData.mat` which contains a discrete-time SISO transfer function `sys2`.

Load the data and use `tfdata` to extract the numerator and denominator coefficients along with the sample time.

```
load('tfData.mat','sys2');  
[num,den,ts] = tfdata(sys2)
```

```
num = 1x1 cell array  
    {[0 0 2 0]}
```

```
den = 1x1 cell array  
    {[4 0 3 -1]}
```

```
ts = 0.1000
```

`num` and `den` are returned as cell arrays. To display data, use `celldisp`.

```
celldisp(num)
```

```
num{1} =
```

```
0 0 2 0
```

```
celldisp(den)
```

```
den{1} =
```

```
4 0 3 -1
```

Extract Identified Transfer Function Data

For this example, estimate a transfer function with 2 poles and 1 zero from identified data contained in `iddata7.mat` with an input delay value.

Load the identified data and estimate the transfer function.

```
load('iddata7.mat');
sys = tfest(z7,2,1,'InputDelay',[1 0]);
```

Extract the numerator, denominator and their standard deviations for the 2-input, 1 output identified transfer function.

```
[num,den,~,sdnum,sdden] = tfdata(sys)

num=1x2 cell array
    {[0 -0.5212 1.1886]}    {[0 0.0552 -0.0013]}

den=1x2 cell array
    {[1 0.3390 0.2353]}    {[1 0.0360 0.0314]}

sdnum=1x2 cell array
    {[0 0.1311 0.0494]}    {[0 0.0246 0.0033]}

sdden=1x2 cell array
    {[0 0.0183 0.0085]}    {[0 0.0278 0.0048]}
```

Extract Data from Specific Model in Transfer Function Array

For this example, extract numerator and denominator coefficients for a specific transfer function contained in the 3x1 array of continuous-time transfer functions `sys`.

Load the data and extract the numerator and denominator coefficients of the second model in the array.

```
load('tfArray.mat','sys');
[num,den] = tfdata(sys,2);
```

Use `celldisp` to visualize the data in the cell array `num` and `den`.

```
celldisp(num)
```

```
num{1} =
    0    0    2
```

```
celldisp(den)
```

```
den{1} =
```

```
1 1 2
```

Input Arguments

sys — Dynamic system

dynamic system model | model array

Dynamic system, specified as a SISO or MIMO dynamic system model, or an array of SISO or MIMO dynamic system models. Dynamic systems that you can use include continuous-time or discrete-time numeric LTI models such as `tf`, `ss` and `zpk` models.

If `sys` is a state-space or zero-pole-gain model, it is first converted to transfer function form using `tf`. For more information on the format of transfer function model data, see the `tf` reference page.

For SISO transfer functions, use the following syntax to return the numerator and denominator coefficients directly as row vectors rather than as cell arrays:

```
[num,den] = tfdata(sys,'v')
```

J1, ..., JN — Indices of models in array whose data you want to access

positive integer

Indices of models in array whose data you want to access, specified as a positive integer. You can provide as many indices as there are array dimensions in `sys`. For example, if `sys` is a 4-by-5 array of transfer functions, the following command accesses the data for entry (2,3) in the array.

```
[num,den] = tfdata(sys,2,3);
```

Output Arguments

num — Coefficients of the numerator

cell array | row vector

Coefficients of the numerator of the transfer function, returned as a cell array or row vector.

When `sys` contains a single LTI model, the output `num` is returned as a cell array with the following characteristics:

- `num` has as many rows as outputs and as many columns as inputs of `sys`.
- The (i, j) entries in `num{i, j}` are row vectors specifying the numerator coefficients of the transfer function from input `j` to output `i`. `tfdata` orders these coefficients in *descending* powers of `s` or `z`.

When `sys` contains an array of LTI models, `num` is returned as a multidimensional cell array of the same size as `sys`.

den — Coefficients of the denominator

cell array | row vector

Coefficients of the denominator of the transfer function, returned as a cell array or row vector.

When `sys` contains a single LTI model, the output `den` is returned as a cell array with the following characteristics:

- `den` has as many rows as outputs and as many columns as inputs of `sys`.
- The (i, j) entries in `den{i, j}` are row vectors specifying the denominator coefficients of the transfer function from input j to output i . `tfdata` orders these coefficients in *descending* powers of s or z .

When `sys` contains an array of LTI models, `den` is returned as a multidimensional cell array of the same size as `sys`.

ts — Sample time

non-negative scalar

Sample time, returned as a non-negative scalar.

snum — Standard uncertainty of the numerator coefficients

cell array

Standard uncertainty of the numerator coefficients of the identified system `sys`, returned as a cell array of the same size as `num`. `snum{i, j}(k)` is the 1 standard uncertainty in the value `num{i, j}(k)`. If `sys` does not contain uncertainty information, `snum` is empty `[]`.

sdden — Standard uncertainty the denominator coefficients

cell array

Standard uncertainty of the denominator coefficients of the identified system `sys`, returned as a cell array of the same size as `den`. `sdden{i, j}(k)` is the 1 standard uncertainty in the value `den{i, j}(k)`. If `sys` does not contain uncertainty information, `sdden` is empty `[]`.

Version History

Introduced before R2006a

See Also

`tf` | `ss` | `zpk` | `get` | `ssdata` | `zpkdata`

thiran

Generate fractional delay filter based on Thiran approximation

Syntax

```
sys = thiran(tau,Ts)
```

Description

`sys = thiran(tau,Ts)` discretizes the continuous-time delay `tau` using a Thiran filter to approximate the fractional part of the delay. `Ts` specifies the sample time of the filter, which is returned as a discrete-time transfer function model. The Thiran fractional-delay filter has the following form:

$$H(z) = \frac{a_N z^N + a_{N-1} z^{N-1} + \dots + a_0}{a_0 z^N + a_1 z^{N-1} + \dots + a_N}.$$

The coefficients a_0, \dots, a_N are given by:

$$a_k = (-1)^k \binom{N}{k} \prod_{i=0}^N \frac{D - N + i}{D - N + k + i}, \quad \forall k: 1, 2, \dots, N$$

$$a_0 = 1$$

where $D = \tau/T_s$ and $N = \text{ceil}(D)$ is the filter order. See [1].

Examples

Approximate and Discretize Time Delay

Approximate and discretize a time delay of 2.4 s with a sample time of 1 s.

```
sys = thiran(2.4,1)
```

```
sys =
```

$$\frac{0.004159 z^3 - 0.04813 z^2 + 0.5294 z + 1}{z^3 + 0.5294 z^2 - 0.04813 z + 0.004159}$$

```
Sample time: 1 seconds
Discrete-time transfer function.
```

The time delay is not an integer multiple of the sample time. Therefore, the approximation `sys` is a discrete-time transfer function of order 3.

Time Delay of Integer Multiple of Sample Time

Discretize a time delay of 2.5 s with a sample time of 0.5 s.

```
sys = thiran(2.5,0.5)
```

```
sys =
```

```
    1
    ---
    z^5
```

```
Sample time: 0.5 seconds
Discrete-time transfer function.
```

Here, the time delay is an exactly five times the target sample time. Therefore, `sys` is a pure discrete delay of order 5.

Input Arguments

tau — Time delay

positive scalar

Time delay to discretize, specified as a positive scalar value. `thiran` assumes that `tau` is in seconds.

Ts — Sample time

positive scalar

Sample time of discretized approximation of time delay, specified as a positive scalar value. `thiran` assumes that `Ts` is in seconds.

Output Arguments

sys — Discretized approximation of time delay

tf model

Discretized approximation of time delay, returned as a discrete-time transfer function (tf) model with sample time `Ts`.

- If `tau` is an integer multiple of `Ts`, then `sys` represents the pure discrete delay z^{-N} , with $N = \text{tau}/T_s$.
- Otherwise, `sys` is a discrete-time, all-pass, infinite impulse response (IIR) filter of order `ceil(tau/Ts)`.

The filter is a discrete-time, all-pass, infinite impulse response (IIR) filter of order `ceil(tau/Ts)`. The unit `sys.TimeUnit` is 'seconds'.

Tips

- `thiran` approximates and discretizes a pure time delay. To approximate a pure continuous-time time delay without discretizing, use `pade`. To discretize continuous-time models having time delays, use `c2d`.

Version History

Introduced in R2010a

References

- [1] T. Laakso, V. Valimaki, "Splitting the Unit Delay", *IEEE Signal Processing Magazine*, Vol. 13, No. 1, p.30-60, 1996.

See Also

c2d | pade | tf

timeoptions

Create list of time plot options

Description

Use the `timeoptions` command to create a `TimeOptions` object to customize time plot appearance. You can also use the command to override the plot preference settings in the MATLAB session in which you create the time plots.

Creation

Syntax

```
plotoptions = timeoptions  
plotoptions = timeoptions('cstprefs')
```

Description

`plotoptions = timeoptions` returns a list of available options for time plots with default values set. You can use these options to customize the time plot appearance from the command line.

`plotoptions = timeoptions('cstprefs')` initializes the plot options with options you selected in the Control System Toolbox and System Identification Toolbox Preferences Editor. For more information about the editor, see “Toolbox Preferences Editor”. This syntax is useful when you want to change a few plot options but otherwise use your default preferences. A script that uses this syntax may generate results that look different when run in a session with different preferences.

Properties

Normalize — Toggle response normalization

'off' (default) | 'on'

Toggle response normalization, specified as either 'on' or 'off'.

SettleTimeThreshold — Settling time threshold

0.02 (default) | positive scalar

Settling time threshold, specified as a positive scalar between values 0 and 1.

RiseTimeLimits — Rise time limits

[0.1,0.9] (default) | two-element vector of the form [min,max]

Rise time limits between the values of 0 and 1, specified as a two-element vector of the form [min,max].

TimeUnits — Time units

'seconds' (default)

Time units, specified as one of the following values:

- 'nanoseconds'
- 'microseconds'
- 'milliseconds'
- 'seconds'
- 'minutes'
- 'hours'
- 'days'
- 'weeks'
- 'months'
- 'years'

You can also specify 'auto' which uses time units specified in the `TimeUnit` property of the input system. For multiple systems with different time units, the units of the first system is used.

ConfidenceRegionNumberSD — Number of standard deviations to use to plot the confidence region

1 (default) | scalar

Number of standard deviations to use to plot the confidence region, specified as a scalar. This is applicable to identified models only.

IOMGrouping — Grouping of input-output pairs

'none' (default) | 'inputs' | 'outputs' | 'all'

Grouping of input-output (I/O) pairs, specified as one of the following:

- 'none' — No input-output grouping.
- 'inputs' — Group only the inputs.
- 'outputs' — Group only the outputs.
- 'all' — Group all the I/O pairs.

InputLabels — Input label style

structure (default)

Input label style, specified as a structure with the following fields:

- `FontSize` — Font size, specified as a scalar value greater than zero in point units. The default font size depends on the specific operating system and locale. One point equals 1/72 inch.
- `FontWeight` — Character thickness, specified as 'Normal' or 'bold'. MATLAB uses the `FontWeight` property to select a font from those available on your system. Not all fonts have a bold weight. Therefore, specifying a bold font weight can still result in the normal font weight.
- `FontAngle` — Character slant, specified as 'Normal' or 'italic'. Not all fonts have both font styles. Therefore, the italic font might look the same as the normal font.
- `Color` — Text color, specified as an RGB triplet. The default color is dark grey with the RGB triplet `[0.4, 0.4, 0.4]`.
- `Interpreter` — Text interpreter, specified as one of these values:

- `'tex'` — Interpret characters using a subset of TeX markup. This is the default value of `Interpreter`.
- `'latex'` — Interpret characters using LaTeX markup.
- `'none'` — Display literal characters.

OutputLabels — Output label style

structure (default)

Output label style, specified as a structure with the following fields:

- `FontSize` — Font size, specified as a scalar value greater than zero in point units. The default font size depends on the specific operating system and locale. One point equals 1/72 inch.
- `FontWeight` — Character thickness, specified as `'Normal'` or `'bold'`. MATLAB uses the `FontWeight` property to select a font from those available on your system. Not all fonts have a bold weight. Therefore, specifying a bold font weight can still result in the normal font weight.
- `FontAngle` — Character slant, specified as `'Normal'` or `'italic'`. Not all fonts have both font styles. Therefore, the italic font might look the same as the normal font.
- `Color` — Text color, specified as an RGB triplet. The default color is dark grey with the RGB triplet `[0.4, 0.4, 0.4]`.
- `Interpreter` — Text interpreter, specified as one of these values:
 - `'tex'` — Interpret characters using a subset of TeX markup. This is the default value of `Interpreter`.
 - `'latex'` — Interpret characters using LaTeX markup.
 - `'none'` — Display literal characters.

InputVisible — Toggle display of inputs

`{'on'}` (default) | `{'off'}`

Toggle display of inputs, specified as either `{'on'}` or `{'off'}`.

OutputVisible — Toggle display of outputs

`{'on'}` (default) | `{'off'}`

Toggle display of outputs, specified as either `{'on'}` or `{'off'}`.

Title — Title text and style

structure (default)

Title text and style, specified as a structure with the following fields:

- `String` — Label text, specified as a character vector. By default, the plot is titled 'Time Response'.
- `FontSize` — Font size, specified as a scalar value greater than zero in point units. The default font size depends on the specific operating system and locale. One point equals 1/72 inch.
- `FontWeight` — Character thickness, specified as `'Normal'` or `'bold'`. MATLAB uses the `FontWeight` property to select a font from those available on your system. Not all fonts have a bold weight. Therefore, specifying a bold font weight can still result in the normal font weight.
- `FontAngle` — Character slant, specified as `'Normal'` or `'italic'`. Not all fonts have both font styles. Therefore, the italic font might look the same as the normal font.
- `Color` — Text color, specified as an RGB triplet. The default color is black specified by the RGB triplet `[0, 0, 0]`.

- **Interpreter** — Text interpreter, specified as one of these values:
 - 'tex' — Interpret characters using a subset of TeX markup. This is the default value of **Interpreter**.
 - 'latex' — Interpret characters using LaTeX markup.
 - 'none' — Display literal characters.

XLabel — X-axis label text and style

structure (default)

X-axis label text and style, specified as a structure with the following fields:

- **String** — Label text, specified as a character vector. By default, the axis is titled 'Time'.
- **FontSize** — Font size, specified as a scalar value greater than zero in point units. The default font size depends on the specific operating system and locale. One point equals 1/72 inch.
- **FontWeight** — Character thickness, specified as 'Normal' or 'bold'. MATLAB uses the **FontWeight** property to select a font from those available on your system. Not all fonts have a bold weight. Therefore, specifying a bold font weight can still result in the normal font weight.
- **FontAngle** — Character slant, specified as 'Normal' or 'italic'. Not all fonts have both font styles. Therefore, the italic font might look the same as the normal font.
- **Color** — Text color, specified as an RGB triplet. The default color is black specified by the RGB triplet [0, 0, 0].
- **Interpreter** — Text interpreter, specified as one of these values:
 - 'tex' — Interpret characters using a subset of TeX markup. This is the default value of **Interpreter**.
 - 'latex' — Interpret characters using LaTeX markup.
 - 'none' — Display literal characters.

YLabel — Y-axis label text and style

structure (default)

Y-axis label text and style, specified as a structure with the following fields:

- **String** — Label text, specified as a cell array of character vectors. By default, the axis is titled 'Amplitude'.
- **FontSize** — Font size, specified as a scalar value greater than zero in point units. The default font size depends on the specific operating system and locale. One point equals 1/72 inch.
- **FontWeight** — Character thickness, specified as 'Normal' or 'bold'. MATLAB uses the **FontWeight** property to select a font from those available on your system. Not all fonts have a bold weight. Therefore, specifying a bold font weight can still result in the normal font weight.
- **FontAngle** — Character slant, specified as 'Normal' or 'italic'. Not all fonts have both font styles. Therefore, the italic font might look the same as the normal font.
- **Color** — Text color, specified as an RGB triplet. The default color is black specified by the RGB triplet [0, 0, 0].
- **Interpreter** — Text interpreter, specified as one of these values:
 - 'tex' — Interpret characters using a subset of TeX markup. This is the default value of **Interpreter**.

- `'latex'` — Interpret characters using LaTeX markup.
- `'none'` — Display literal characters.

TickLabel — Tick label style

structure (default)

Tick label style, specified as a structure with the following fields:

- `FontSize` — Font size, specified as a scalar value greater than zero in point units. The default font size depends on the specific operating system and locale. One point equals 1/72 inch.
- `FontWeight` — Character thickness, specified as `'Normal'` or `'bold'`. MATLAB uses the `FontWeight` property to select a font from those available on your system. Not all fonts have a bold weight. Therefore, specifying a bold font weight can still result in the normal font weight.
- `FontAngle` — Character slant, specified as `'Normal'` or `'italic'`. Not all fonts have both font styles. Therefore, the italic font might look the same as the normal font.
- `Color` — Text color, specified as an RGB triplet. The default color is black specified by the RGB triplet `[0,0,0]`.

Grid — Toggle grid display

`'off'` (default) | `'on'`

Toggle grid display on the plot, specified as either `'off'` or `'on'`.

GridColor — Color of the grid lines

`[0.15,0.15,0.15]` (default) | RGB triplet

Color of the grid lines, specified as an RGB triplet. The default color is light grey specified by the RGB triplet `[0.15,0.15,0.15]`.

XLimMode — X-axis limit selection mode

`'auto'` (default) | `'manual'`

Selection mode for the x-axis limits, specified as one of these values:

- `'auto'` — Enable automatic limit selection, which is based on the total span of the plotted data.
- `'manual'` — Manually specify the axis limits. To specify the axis limits, set the `XLim` property.

YLimMode — Y-axis limit selection mode

`'auto'` (default) | `'manual'`

Selection mode for the y-axis limits, specified as one of these values:

- `'auto'` — Enable automatic limit selection, which is based on the total span of the plotted data.
- `'manual'` — Manually specify the axis limits. To specify the axis limits, set the `YLim` property.

XLim — X-axis limits

`'{[1,10]}'` (default) | cell array of two-element vector of the form `[min,max]`

X-axis limits, specified as a cell array of two-element vector of the form `[min,max]`.

YLim — Y-axis limits

`'{[1,10]}'` (default) | cell array of two-element vector of the form `[min,max]`

Y-axis limits, specified as a cell array of two-element vector of the form `[min,max]`.

Object Functions

getoptions	Return plot options handle or plot options property
impzplot	Plot impulse response with additional plot customization options
initialplot	Plot initial condition response with additional plot customization options
lsimplot	Plot simulated time response of dynamic system to arbitrary inputs with additional plot customization options
setoptions	Set plot options handle or plot options property
stepplot	Plot step response with additional plot customization options

Examples

Plot Normalized Step Response

Create a default time options set.

```
opt = timeoptions;
```

Enable plotting of normalized responses.

```
opt.Normalize = 'on';
```

Plot the step response of two transfer function models using the specified options.

```
sys1 = tf(10,[1,1]);  
sys2 = tf(5,[1,5]);  
stepplot(sys1,sys2,opt);
```

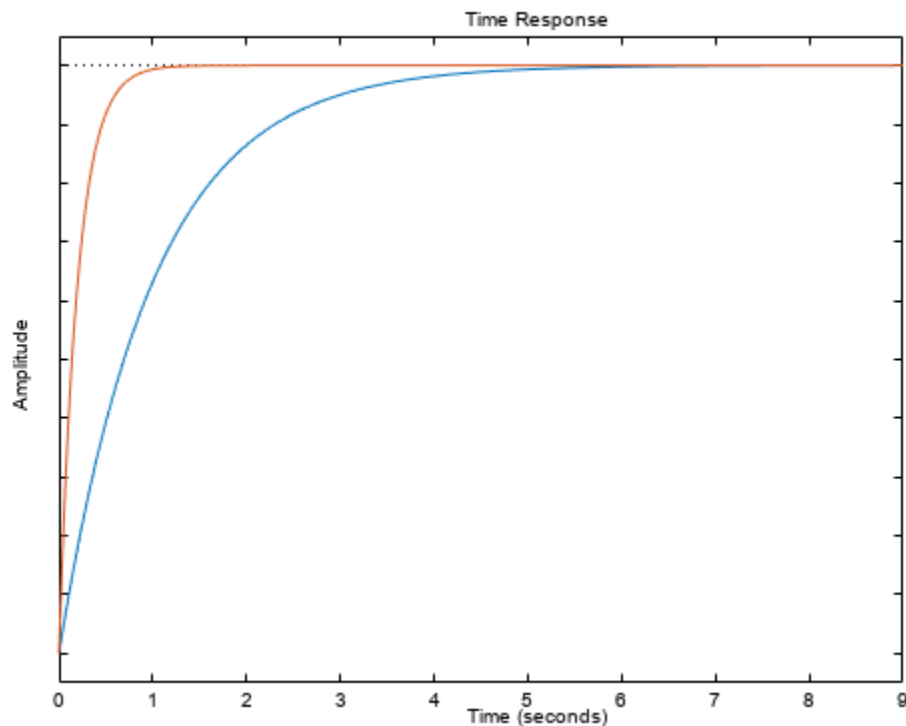

The plot shows the normalized step response for the two transfer function models.

Customize Step Plot using Plot Handle

For this example, use the plot handle to change the time units to minutes and turn on the grid.

Generate a random state-space model with 5 states and create the step response plot with plot handle `h`.

```
rng("default")
sys = rss(5);
h = stepplot(sys);
```

Change the time units to minutes and turn on the grid. To do so, edit properties of the plot handle, `h` using `setoptions`.

```
setoptions(h, 'TimeUnits', 'minutes', 'Grid', 'on');
```

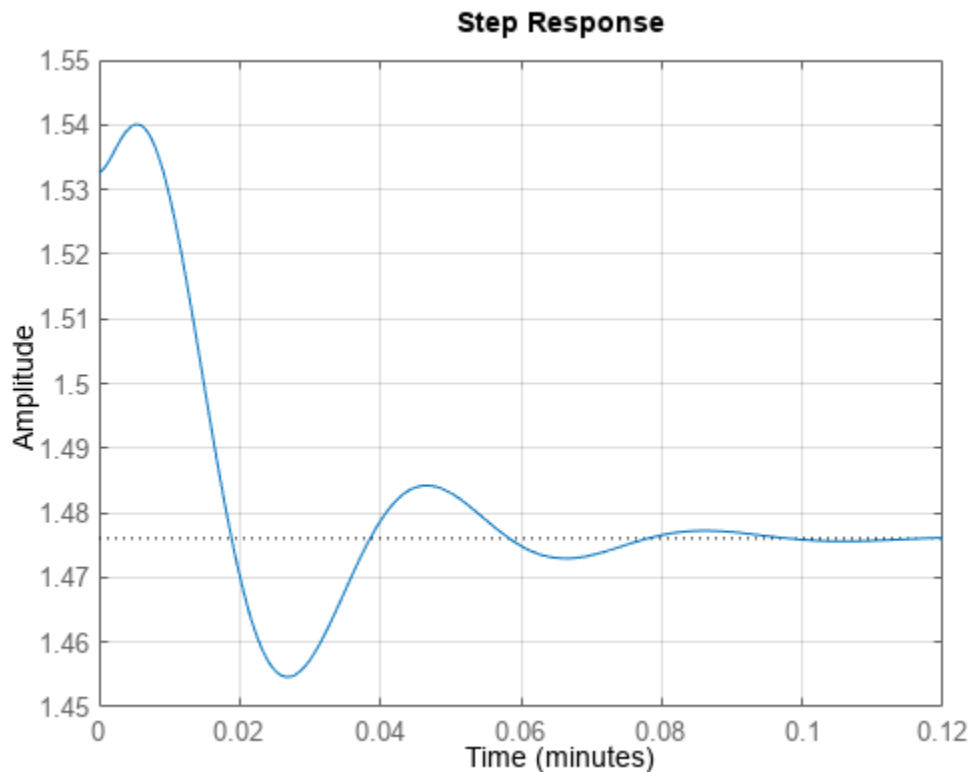

The step plot automatically updates when you call `setoptions`.

Alternatively, you can also use the `timeoptions` command to specify the required plot options. First, create an options set based on the toolbox preferences.

```
plotoptions = timeoptions('cstprefs');
```

Change properties of the options set by setting the time units to minutes and enabling the grid.

```
plotoptions.TimeUnits = 'minutes';
plotoptions.Grid = 'on';
stepplot(sys,plotoptions);
```

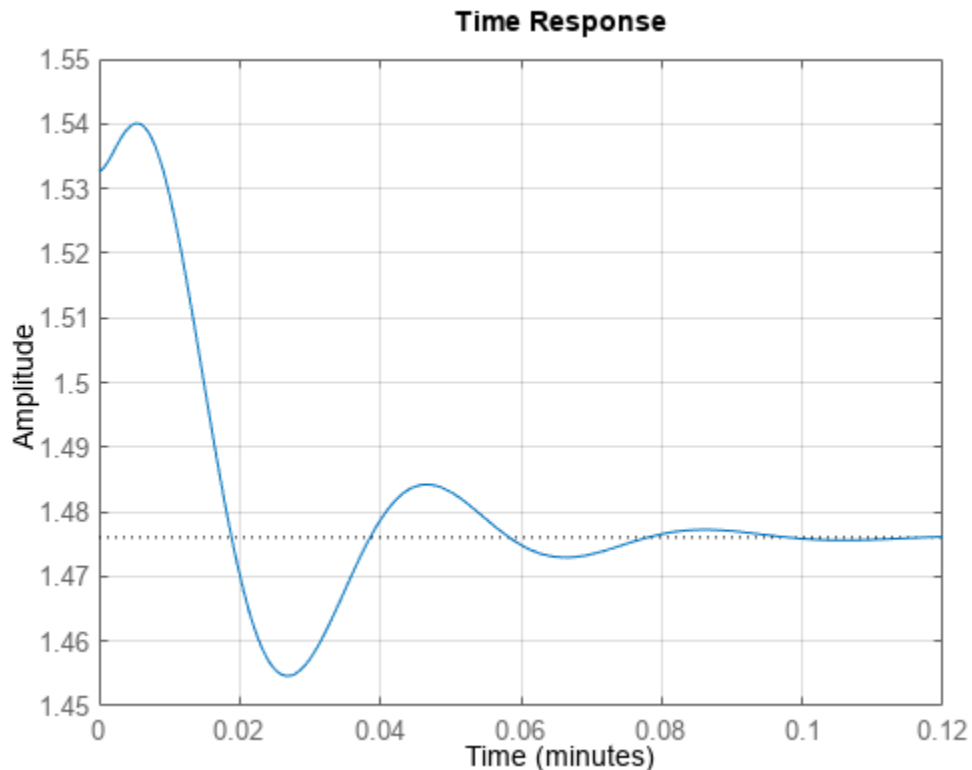

You can use the same option set to create multiple step plots with the same customization. Depending on your own toolbox preferences, the plot you obtain might look different from this plot. Only the properties that you set explicitly, in this example `TimeUnits` and `Grid`, override the toolbox preferences.

Customized Step Response Plot at Specified Time

For this example, examine the step response of the following zero-pole-gain model and limit the step plot to `tFinal = 15 s`. Use 15-point blue text for the title. This plot should look the same, regardless of the preferences of the MATLAB session in which it is generated.

```
sys = zp(-1,[-0.2+3j,-0.2-3j],1)*tf([1 1],[1 0.05]);
tFinal = 15;
```

First, create a default options set using `timeoptions`.

```
plotoptions = timeoptions;
```

Next change the required properties of the options set `plotoptions`.

```

plotoptions.Title.FontSize = 15;
plotoptions.Title.Color = [0 0 1];

```

Now, create the step response plot using the options set `plotoptions`.

```

h = stepplot(sys,tFinal,plotoptions);

```

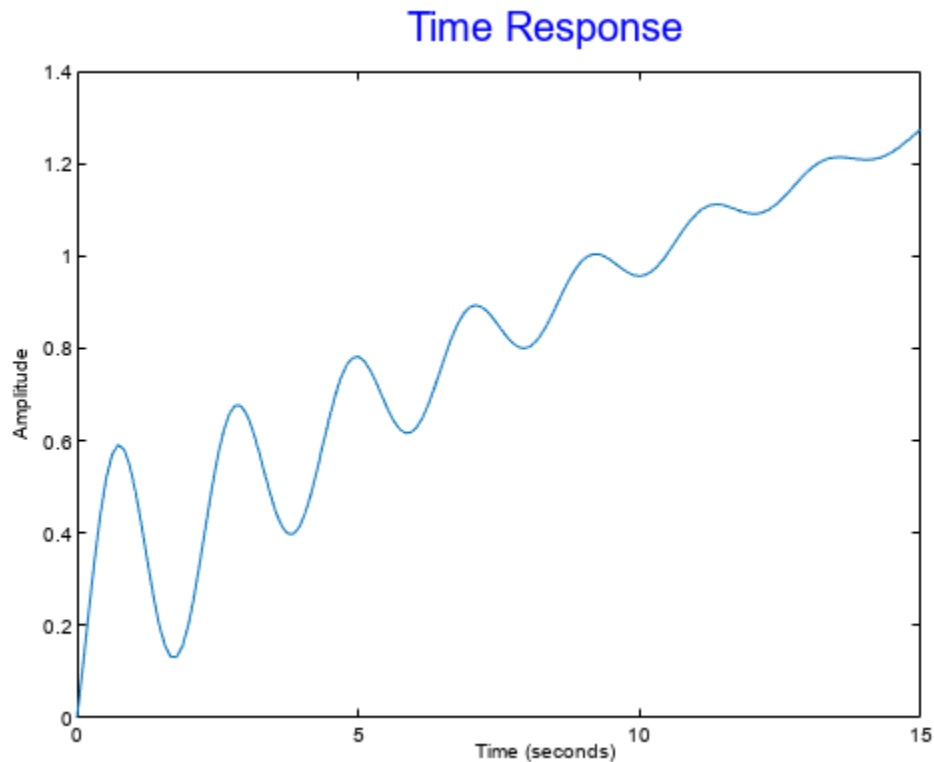

Because `plotoptions` begins with a fixed set of options, the plot result is independent of the toolbox preferences of the MATLAB session.

Custom Plot of System Evolution from Initial Condition

By default, `lsimplot` simulates the model assuming all states are zero at the start of the simulation. When simulating the response of a state-space model, use the optional `x0` input argument to specify nonzero initial state values. Consider the following two-state SISO state-space model.

```

A = [-1.5 -3;
      3   -1];
B = [1.3; 0];
C = [1.15 2.3];
D = 0;
sys = ss(A,B,C,D);

```

Suppose that you want to allow the system to evolve from a known set of initial states with no input for 2 s, and then apply a unit step change. Specify the vector x_0 of initial state values, and create the input vector.

```
x0 = [-0.2 0.3];
t = 0:0.05:8;
u = zeros(length(t),1);
u(t>=2) = 1;
```

First, create a default options set using `timeoptions`.

```
plotoptions = timeoptions;
```

Next change the required properties of the options set `plotoptions` and plot the simulated response with the zero order hold option.

```
plotoptions.Title.FontSize = 15;
plotoptions.Title.Color = [0 0 1];
plotoptions.Grid = 'on';
h = lsimplot(sys,u,t,x0,plotoptions,'zoh');
hold on
title('Simulated Time Response with Initial Conditions')
```

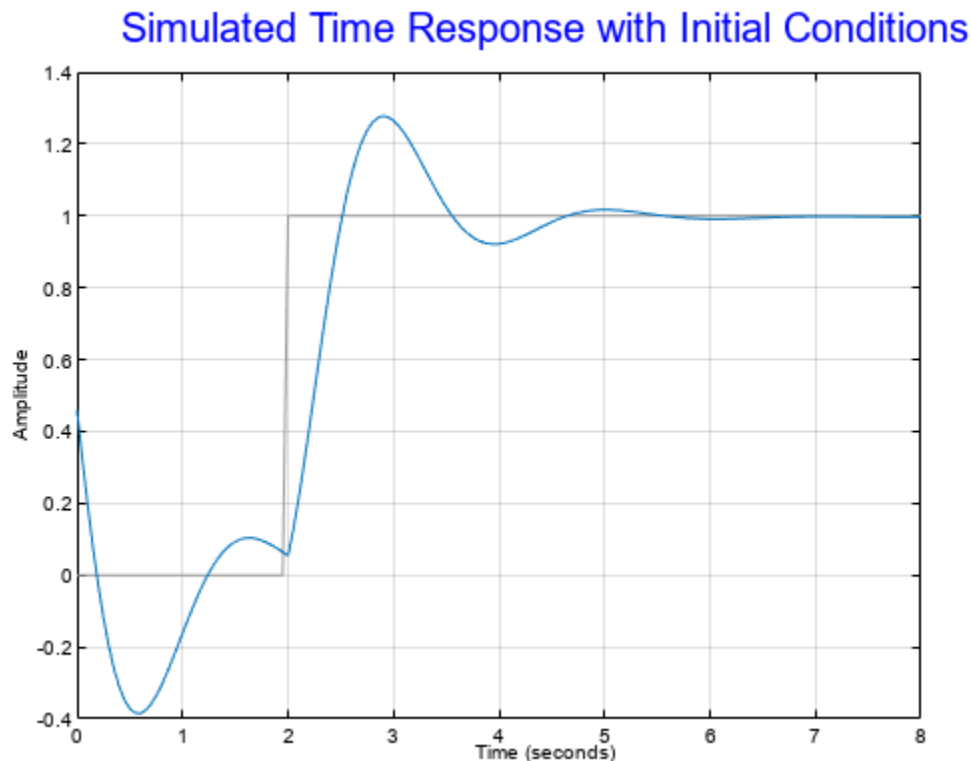

The first half of the plot shows the free evolution of the system from the initial state values $[-0.2 \ 0.3]$. At $t = 2$ there is a step change to the input, and the plot shows the system response to this new signal beginning from the state values at that time. Because `plotoptions` begins with a fixed set of options, the plot result is independent of the toolbox preferences of the MATLAB session.

Customized Plot of Simulated Response to Arbitrary Input Signal

For this example, change time units to minutes and turn the grid on for the simulated response plot. Consider the following transfer function.

```
sys = tf(3,[1 2 3]);
```

To compute the response of this system to an arbitrary input signal, provide `lsimplot` with a vector of the times `t` at which you want to compute the response and a vector `u` containing the corresponding signal values. For instance, plot the system response to a ramping step signal that starts at 0 at time `t = 0`, ramps from 0 at `t = 1` to 1 at `t = 2`, and then holds steady at 1. Define `t` and compute the values of `u`.

```
t = 0:0.04:8;
u = max(0,min(t-1,1));
```

Use `lsimplot` plot the system response to the signal with a plot handle `h`.

```
h = lsimplot(sys,u,t);
```

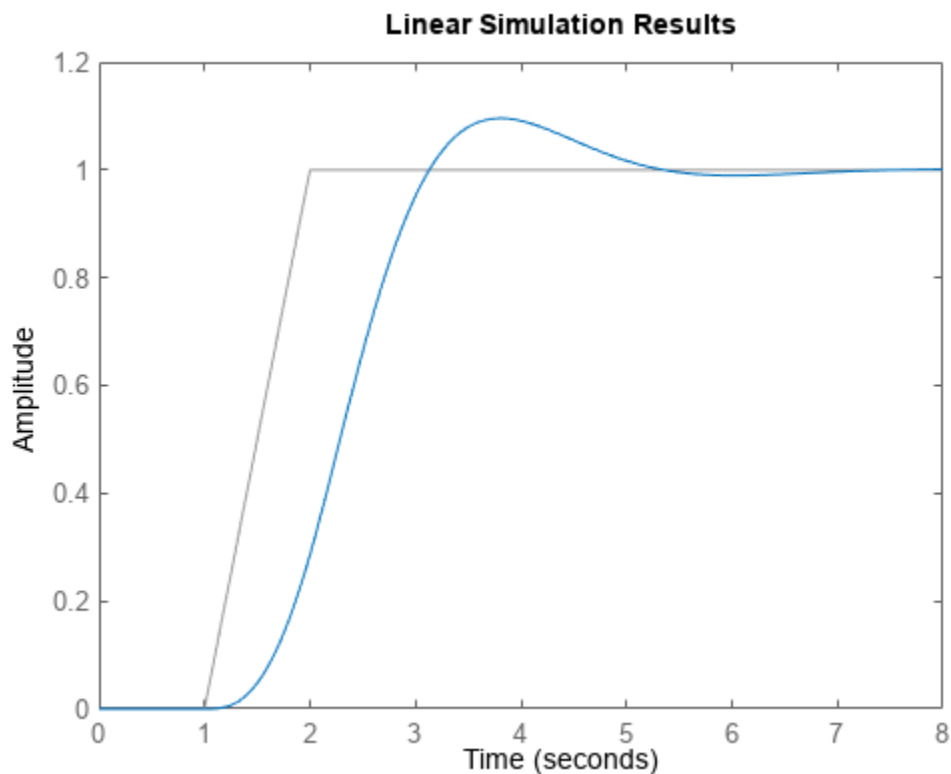

The plot shows the applied input (`u, t`) in gray and the system response in blue.

Use the plot handle to change the time units to minutes and to turn the grid on. To do so, edit properties of the plot handle, `h` using `setoptions`.

```
setoptions(h,'TimeUnits','minutes','Grid','on')
```

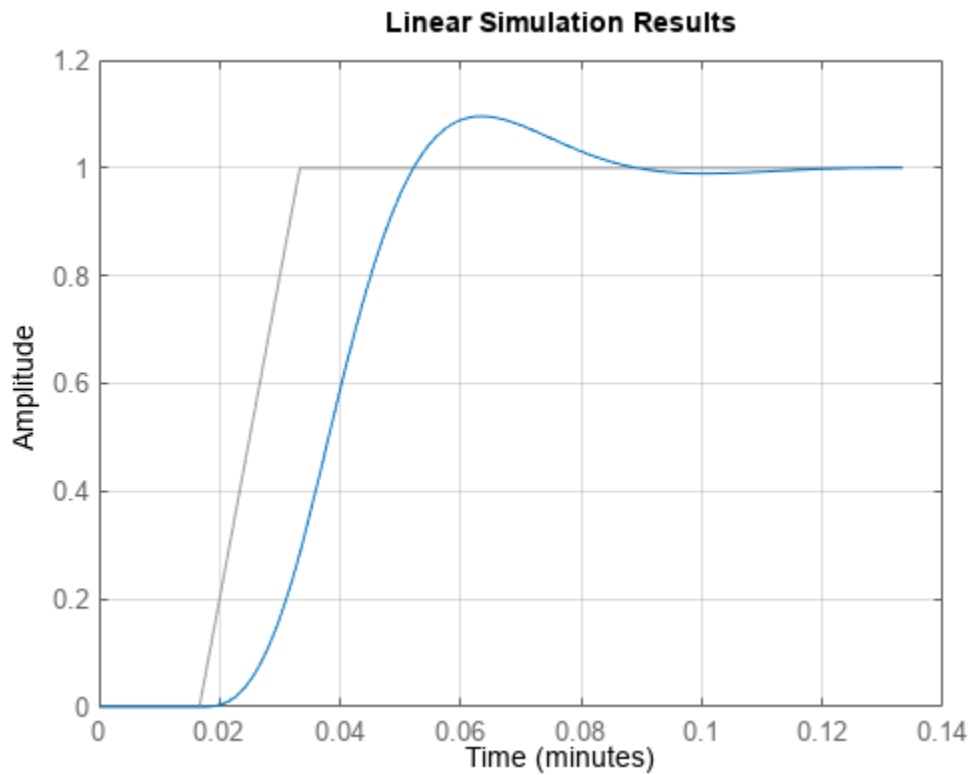

The plot automatically updates when you call `setoptions`.

Alternatively, you can also use the `timeoptions` command to specify the required plot options. First, create an options set based on the toolbox preferences.

```
plotoptions = timeoptions('cstprefs');
```

Change properties of the options set by setting the time units to minutes and enabling the grid.

```
plotoptions.TimeUnits = 'minutes';  
plotoptions.Grid = 'on';  
lsimplot(sys,u,t,plotoptions);
```

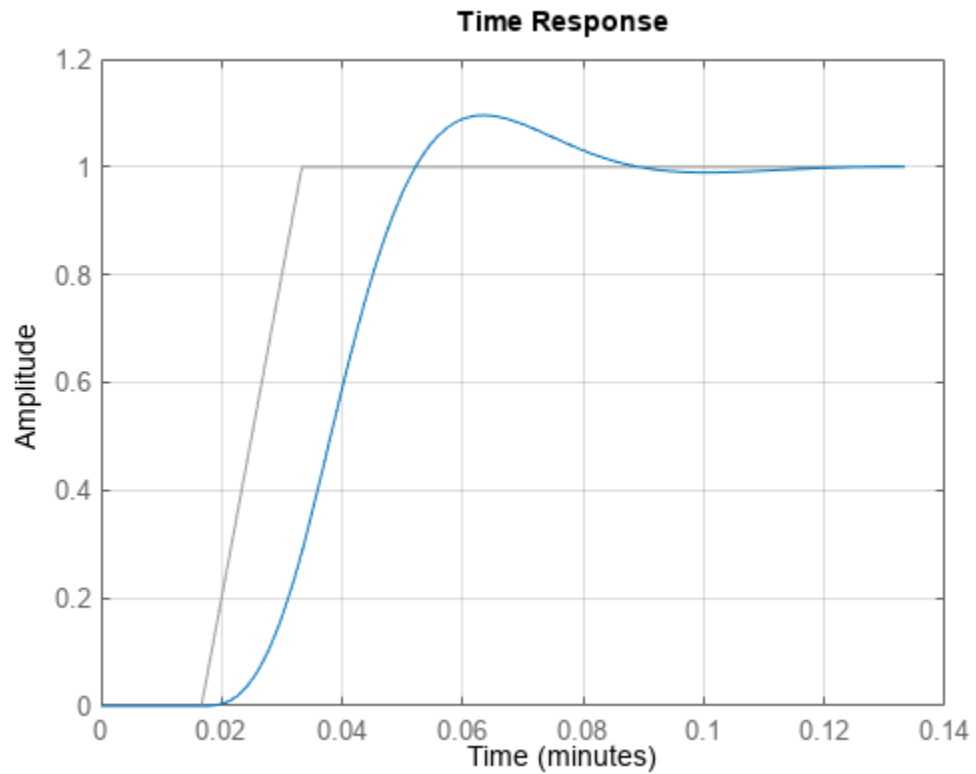

Version History

Introduced in R2008a

See Also

[getoptions](#) | [impzplot](#) | [initialplot](#) | [lsimplot](#) | [setoptions](#) | [stepplot](#)

Topics

“Toolbox Preferences Editor”

totaldelay

Total combined I/O delays for LTI model

Syntax

```
td = totaldelay(sys)
```

Description

`td = totaldelay(sys)` returns the total combined I/O delays for an LTI model `sys`. The matrix `td` combines contributions from the `InputDelay`, `OutputDelay`, and `ioDelayMatrix` properties.

Delays are expressed in seconds for continuous-time models, and as integer multiples of the sample period for discrete-time models. To obtain the delay times in seconds, multiply `td` by the sample time `sys.Ts`.

Examples

Compute Combined Input-Output Delay for Transfer Function

Create the transfer function model, $1/s$.

```
sys = tf(1,[1 0]);
```

Specify a 2 second input delay, and a 1.5 second output delay.

```
sys.InputDelay = 2;  
sys.OutputDelay = 1.5;
```

Compute the combined input-output delay for `sys`.

```
td = totaldelay(sys)
```

```
td = 3.5000
```

The resulting transfer function has the following form:

$$e^{-2s} \times \frac{1}{s} e^{-1.5s} = e^{-3.5s} \frac{1}{s}$$

This result is equivalent to specifying an input-output delay of 3.5 seconds for the original transfer function, $1/s$.

Version History

Introduced before R2006a

See Also

absorbDelay | hasdelay

tunableGain

Tunable static gain block

Syntax

```
blk = tunableGain(name,Ny,Nu)
blk = tunableGain(name,G)
```

Description

Model object for creating tunable static gains. `tunableGain` lets you parametrize tunable static gains for parameter studies or for automatic tuning with tuning commands such as `systemtune` or `looptune`.

`tunableGain` is part of the Control Design Block family of parametric models. Other Control Design Blocks include `tunablePID`, `tunableSS`, and `tunableTF`.

Construction

`blk = tunableGain(name,Ny,Nu)` creates a parametric static gain block named `name`. This block has `Ny` outputs and `Nu` inputs. The tunable parameters are the gains across each of the `Ny`-by-`Nu` I/O channels.

`blk = tunableGain(name,G)` uses the double array `G` to dimension the block and initialize the tunable parameters.

Input Arguments

name

Block Name, specified as a character vector such as 'K' or 'gain1'. (See “Properties” on page 2-1415.)

Ny

Non-negative integer specifying the number of outputs of the parametric static gain block `blk`.

Nu

Non-negative integer specifying the number of inputs of the parametric static gain block `blk`.

G

Double array of static gain values. The number of rows and columns of `G` determine the number of inputs and outputs of `blk`. The entries `G` are the initial values of the parametric gain block parameters.

Properties

Gain

Parametrization of the tunable gain.

`blk.Gain` is a `param.Continuous` object. For general information about the properties of the `param.Continuous` object `blk.Gain`, see the `param.Continuous` object reference page.

The following fields of `blk.Gain` are used when you tune `blk` using `hinfstruct`:

Field	Description
Value	<p>Current value of the gain matrix. For a block that has <code>Ny</code> outputs and <code>Nu</code> inputs, <code>blk.Gain.Value</code> is a <code>Ny-by-Nu</code> matrix.</p> <p>If you use the <code>G</code> input argument to create <code>blk</code>, <code>blk.Gain.Value</code> initializes to the values of <code>G</code>. Otherwise, all entries of <code>blk.Gain.Value</code> initialize to zero.</p> <p><code>hinfstruct</code> tunes all entries in <code>blk.Gain.Value</code> except those whose values are fixed by <code>blk.Gain.Free</code>.</p> <p>Default: Array of zero values</p>
Free	<p>Array of logical values determining whether the gain entries in <code>blk.Gain.Value</code> are fixed or free parameters.</p> <ul style="list-style-type: none"> If <code>blk.Gain.Free(i,j) = 1</code>, then <code>blk.Gain.Value(i,j)</code> is a tunable parameter. If <code>blk.Gain.Free(i,j) = 0</code>, then <code>blk.Gain.Value(i,j)</code> is fixed. <p>Default: Array of 1 (<code>true</code>) values</p>
Minimum	<p>Minimum value of the parameter. This property places a lower bound on the tuned value of the parameter. For example, setting <code>blk.Gain.Minimum = 1</code> ensures that all entries in the gain matrix have gain greater than 1.</p> <p>Default: <code>-Inf</code></p>

Field	Description
Maximum	Maximum value of the parameter. This property places an upper bound on the tuned value of the parameter. For example, setting <code>blk.Gain.Maximum = 100</code> ensures that all entries in the gain matrix have gain less than 100. Default: Inf

Ts

Sample time. For continuous-time models, $T_s = 0$. For discrete-time models, T_s is a positive scalar representing the sampling period. This value is expressed in the unit specified by the `TimeUnit` property of the model. To denote a discrete-time model with unspecified sample time, set $T_s = -1$.

Changing this property does not discretize or resample the model.

Default: 0 (continuous time)

TimeUnit

Units for the time variable, the sample time T_s , and any time delays in the model, specified as one of the following values:

- 'nanoseconds'
- 'microseconds'
- 'milliseconds'
- 'seconds'
- 'minutes'
- 'hours'
- 'days'
- 'weeks'
- 'months'
- 'years'

Changing this property has no effect on other properties, and therefore changes the overall system behavior. Use `chgTimeUnit` to convert between time units without modifying system behavior.

Default: 'seconds'

InputName

Input channel names, specified as one of the following:

- Character vector — For single-input models, for example, 'controls'.
- Cell array of character vectors — For multi-input models.

Alternatively, use automatic vector expansion to assign input names for multi-input models. For example, if `sys` is a two-input model, enter:

```
sys.InputName = 'controls';
```

The input names automatically expand to `{'controls(1)'; 'controls(2)'}`.

You can use the shorthand notation `u` to refer to the `InputName` property. For example, `sys.u` is equivalent to `sys.InputName`.

Input channel names have several uses, including:

- Identifying channels on model display and plots
- Extracting subsystems of MIMO systems
- Specifying connection points when interconnecting models

Default: `''` for all input channels

InputUnit

Input channel units, specified as one of the following:

- Character vector — For single-input models, for example, `'seconds'`.
- Cell array of character vectors — For multi-input models.

Use `InputUnit` to keep track of input signal units. `InputUnit` has no effect on system behavior.

Default: `''` for all input channels

InputGroup

Input channel groups. The `InputGroup` property lets you assign the input channels of MIMO systems into groups and refer to each group by name. Specify input groups as a structure. In this structure, field names are the group names, and field values are the input channels belonging to each group. For example:

```
sys.InputGroup.controls = [1 2];
sys.InputGroup.noise = [3 5];
```

creates input groups named `controls` and `noise` that include input channels 1, 2 and 3, 5, respectively. You can then extract the subsystem from the `controls` inputs to all outputs using:

```
sys(:, 'controls')
```

Default: Struct with no fields

OutputName

Output channel names, specified as one of the following:

- Character vector — For single-output models. For example, `'measurements'`.
- Cell array of character vectors — For multi-output models.

Alternatively, use automatic vector expansion to assign output names for multi-output models. For example, if `sys` is a two-output model, enter:

```
sys.OutputName = 'measurements';
```

The output names automatically expand to `{'measurements(1)'; 'measurements(2)'}`.

You can use the shorthand notation `y` to refer to the `OutputName` property. For example, `sys.y` is equivalent to `sys.OutputName`.

Output channel names have several uses, including:

- Identifying channels on model display and plots
- Extracting subsystems of MIMO systems
- Specifying connection points when interconnecting models

Default: `''` for all output channels

OutputUnit

Output channel units, specified as one of the following:

- Character vector — For single-output models. For example, `'seconds'`.
- Cell array of character vectors — For multi-output models.

Use `OutputUnit` to keep track of output signal units. `OutputUnit` has no effect on system behavior.

Default: `''` for all output channels

OutputGroup

Output channel groups. The `OutputGroup` property lets you assign the output channels of MIMO systems into groups and refer to each group by name. Specify output groups as a structure. In this structure, field names are the group names, and field values are the output channels belonging to each group. For example:

```
sys.OutputGroup.temperature = [1];  
sys.InputGroup.measurement = [3 5];
```

creates output groups named `temperature` and `measurement` that include output channels 1, and 3, 5, respectively. You can then extract the subsystem from all inputs to the measurement outputs using:

```
sys('measurement', :)
```

Default: Struct with no fields

Name

System name, specified as a character vector. For example, `'system_1'`.

Default: `''`

Notes

Any text that you want to associate with the system, stored as a string or a cell array of character vectors. The property stores whichever data type you provide. For instance, if `sys1` and `sys2` are dynamic system models, you can set their `Notes` properties as follows:

```
sys1.Notes = "sys1 has a string.";  
sys2.Notes = 'sys2 has a character vector.';  
sys1.Notes  
sys2.Notes
```

```
ans =
    "sys1 has a string."

ans =
    'sys2 has a character vector.'
```

Default: [0×1 string]

UserData

Any type of data you want to associate with system, specified as any MATLAB data type.

Default: []

Examples

Create a 2-by-2 parametric gain block of the form

$$\begin{bmatrix} g_1 & 0 \\ 0 & g_2 \end{bmatrix}$$

where g_1 and g_2 are tunable parameters, and the off-diagonal elements are fixed to zero.

```
blk = tunableGain('gainblock',2,2); % 2 outputs, 2 inputs
blk.Gain.Free = [1 0; 0 1]; % fix off-diagonal entries to zero
```

All entries in `blk.Gain.Value` initialize to zero. Initialize the diagonal values to 1 as follows.

```
blk.Gain.Value = eye(2); % set diagonals to 1
```

Create a two-input, three-output parametric gain block and initialize all the parameter values to 1.

To do so, create a matrix to dimension the parametric gain block and initialize the parameter values.

```
G = ones(3,2);
blk = tunableGain('gainblock',G);
```

Create a 2-by-2 parametric gain block and assign names to the inputs.

```
blk = tunableGain('gainblock',2,2) % 2 outputs, 2 inputs
blk.InputName = {'Xerror','Yerror'} % assign input names
```

Tips

- Use the `blk.Gain.Free` field of `blk` to specify additional structure or fix the values of specific entries in the block. To fix the gain value from input i to output j , set `blk.Gain.Free(i,j) = 0`. To allow `hinfstruct` to tune this gain value, set `blk.Gain.Free(i,j) = 1`.
- To convert a `tunableGain` parametric model to a numeric (non-tunable) model object, use model commands such as `tf`, `zpk`, or `ss`.

Version History

Introduced in R2016a

Name changed from `ltiblock.gain`

Behavior changed in R2016a

Prior to R2016a, `tunableGain` was called `ltiblock.gain`.

See Also

`tunablePID` | `tunablePID2` | `tunableTF` | `tunableSS` | `system` | `looptune` | `genss` | `hinfstruct`

Topics

“Control Design Blocks”

“Models with Tunable Coefficients”

tunablePID

Tunable PID controller

Syntax

```
blk = tunablePID(name,type)
blk = tunablePID(name,type,Ts)
blk = tunablePID(name,sys)
```

Description

Model object for creating tunable one-degree-of-freedom PID controllers. `tunablePID` lets you parametrize a tunable SISO PID controller for parameter studies or for automatic tuning with tuning commands such as `systune`, `looptune`, or the Robust Control Toolbox command, `hinfstruct`.

`tunablePID` is part of the family of parametric Control Design Blocks. Other parametric Control Design Blocks include `tunableGain`, `tunableSS`, and `tunableTF`.

Construction

`blk = tunablePID(name,type)` creates the one-degree-of-freedom continuous-time PID controller:

$$blk = K_p + \frac{K_i}{s} + \frac{K_d s}{1 + T_f s}$$

with tunable parameters K_p , K_i , K_d , and T_f . The `type` argument sets the controller type by fixing some of these values to zero (see “Input Arguments” on page 2-1421).

`blk = tunablePID(name,type,Ts)` creates a discrete-time PID controller with sample time T_s :

$$blk = K_p + K_i IF(z) + \frac{K_d}{T_f + DF(z)}$$

where $IF(z)$ and $DF(z)$ are the discrete integrator formulas for the integral and derivative terms, respectively. The values of the `IFormula` and `DFormula` properties set the discrete integrator formulas (see “Properties” on page 2-1422).

`blk = tunablePID(name,sys)` uses the dynamic system model, `sys`, to set the sample time, T_s , and the initial values of the parameters K_p , K_i , K_d , and T_f .

Input Arguments

name

PID controller Name, specified as a character vector such as 'C' or 'PI1'. (See “Properties” on page 2-1422.)

type

Controller type, specified as one of the values in the following table. Specifying a controller type fixes up to three of the PID controller parameters.

Value for type	Controller Type	Effect on PID Parameters
'P'	Proportional only	Ki and Kd are fixed to zero; Tf is fixed to 1; Kp is free
'PI'	Proportional-integral	Kd is fixed to zero; Tf is fixed to 1; Kp and Ki are free
'PD'	Proportional-derivative with first-order filter on derivative action	Ki is fixed to zero; Kp, Kd, and Tf are free
'PID'	Proportional-integral-derivative with first-order filter on derivative action	Kp, Ki, Kd, and Tf are free

Ts

Sample time, specified as a scalar.

sys

Dynamic system model representing a PID controller.

Properties

Kp, Ki, Kd, Tf

Parametrization of the PID gains Kp, Ki, Kd, and filter time constant Tf of the tunable PID controller blk.

The following fields of blk.Kp, blk.Ki, blk.Kd, and blk.Tf are used when you tune blk using a tuning command such as systune:

Field	Description
Value	Current value of the parameter.
Free	Logical value determining whether the parameter is fixed or tunable. For example, <ul style="list-style-type: none"> If blk.Kp.Free = 1, then blk.Kp.Value is tunable. If blk.Kp.Free = 0, then blk.Kp.Value is fixed.

Field	Description
Minimum	Minimum value of the parameter. This property places a lower bound on the tuned value of the parameter. For example, setting <code>blk.Kp.Minimum = 0</code> ensures that Kp remains positive. <code>blk.Tf.Minimum</code> must always be positive.
Maximum	Maximum value of the parameter. This property places an upper bound on the tuned value of the parameter. For example, setting <code>blk.Tf.Maximum = 100</code> ensures that the filter time constant does not exceed 100.

`blk.Kp`, `blk.Ki`, `blk.Kd`, and `blk.Tf` are `param.Continuous` objects. For general information about the properties of these `param.Continuous` objects, see the `param.Continuous` object reference page.

IFormula, DFormula

Discrete integrator formulas $IF(z)$ and $DF(z)$ for the integral and derivative terms, respectively, specified as one of the values in the following table.

Value	IF(z) or DF(z) Formula
'ForwardEuler'	$\frac{T_s}{z-1}$
'BackwardEuler'	$\frac{T_s z}{z-1}$
'Trapezoidal'	$\frac{T_s z + 1}{2 z - 1}$

Default: 'ForwardEuler'

Ts

Sample time. For continuous-time models, $T_s = 0$. For discrete-time models, T_s is a positive scalar representing the sampling period. This value is expressed in the unit specified by the `TimeUnit` property of the model. Unspecified sample time ($T_s = -1$) is not supported for PID blocks.

Changing this property does not discretize or resample the model.

Default: 0 (continuous time)

TimeUnit

Units for the time variable, the sample time T_s , and any time delays in the model, specified as one of the following values:

- 'nanoseconds'
- 'microseconds'

- 'milliseconds'
- 'seconds'
- 'minutes'
- 'hours'
- 'days'
- 'weeks'
- 'months'
- 'years'

Changing this property has no effect on other properties, and therefore changes the overall system behavior. Use `chgTimeUnit` to convert between time units without modifying system behavior.

Default: 'seconds'

InputName

Input channel name, specified as a character vector. Use this property to name the input channel of the controller model. For example, assign the name `error` to the input of a controller model `C` as follows.

```
C.InputName = 'error';
```

You can use the shorthand notation `u` to refer to the `InputName` property. For example, `C.u` is equivalent to `C.InputName`.

Input channel names have several uses, including:

- Identifying channels on model display and plots
- Specifying connection points when interconnecting models

Default: Empty character vector, ''

InputUnit

Input channel units, specified as a character vector. Use this property to track input signal units. For example, assign the concentration units `mol/m^3` to the input of a controller model `C` as follows.

```
C.InputUnit = 'mol/m^3';
```

`InputUnit` has no effect on system behavior.

Default: Empty character vector, ''

InputGroup

Input channel groups. This property is not needed for PID controller models.

Default: struct with no fields

OutputName

Output channel name, specified as a character vector. Use this property to name the output channel of the controller model. For example, assign the name `control` to the output of a controller model `C` as follows.

```
C.OutputName = 'control';
```

You can use the shorthand notation `y` to refer to the `OutputName` property. For example, `C.y` is equivalent to `C.OutputName`.

Input channel names have several uses, including:

- Identifying channels on model display and plots
- Specifying connection points when interconnecting models

Default: Empty character vector, ''

OutputUnit

Output channel units, specified as a character vector. Use this property to track output signal units. For example, assign the unit `Volts` to the output of a controller model `C` as follows.

```
C.OutputUnit = 'Volts';
```

`OutputUnit` has no effect on system behavior.

Default: Empty character vector, ''

OutputGroup

Output channel groups. This property is not needed for PID controller models.

Default: struct with no fields

Name

System name, specified as a character vector. For example, 'system_1'.

Default: ''

Notes

Any text that you want to associate with the system, stored as a string or a cell array of character vectors. The property stores whichever data type you provide. For instance, if `sys1` and `sys2` are dynamic system models, you can set their `Notes` properties as follows:

```
sys1.Notes = "sys1 has a string.";
sys2.Notes = 'sys2 has a character vector.';
sys1.Notes
sys2.Notes
```

```
ans =
```

```
    "sys1 has a string."
```

```
ans =
```

```
    'sys2 has a character vector.'
```

Default: [0×1 string]

UserData

Any type of data you want to associate with system, specified as any MATLAB data type.

Default: []

Examples

Tunable Controller with a Fixed Parameter

Create a tunable PD controller. Then, initialize the parameter values, and fix the filter time constant.

```
blk = tunablePID('pblock','PD');
blk.Kp.Value = 4;           % initialize Kp to 4
blk.Kd.Value = 0.7;        % initialize Kd to 0.7
blk.Tf.Value = 0.01;       % set parameter Tf to 0.01
blk.Tf.Free = false;       % fix parameter Tf to this value
blk
```

blk =

Parametric continuous-time PID controller "pblock" with formula:

$$K_p + K_d * \frac{s}{T_f * s + 1}$$

and tunable parameters Kp, Kd.

Type "pid(blk)" to see the current value and "get(blk)" to see all properties.

Controller Initialized by Dynamic System Model

Create a tunable discrete-time PI controller. Use a pid object to initialize the parameters and other properties.

```
C = pid(5,2.2,'Ts',0.1,'IFormula','BackwardEuler');
blk = tunablePID('piblock',C)
```

blk =

Parametric discrete-time PID controller "piblock" with formula:

$$K_p + K_i * \frac{T_s * z}{z - 1}$$

and tunable parameters Kp, Ki.

Type "pid(blk)" to see the current value and "get(blk)" to see all properties.

blk takes the value of properties, such as Ts and IFormula, from C.

Controller with Named Input and Output

Create a tunable PID controller, and assign names to the input and output.

```
blk = tunablePID('pidblock','pid')
blk.InputName = {'error'}      % assign input name
blk.OutputName = {'control'}   % assign output name
```

Tips

- You can modify the PID structure by fixing or freeing any of the parameters K_p , K_i , K_d , and T_f . For example, `blk.Tf.Free = false` fixes T_f to its current value.
- To convert a `tunablePID` parametric model to a numeric (nontunable) model object, use model commands such as `pid`, `pidstd`, `tf`, or `ss`. You can also use `getValue` to obtain the current value of a tunable model.

Version History

Introduced in R2016a

Name changed from `ltiblock.pid`

Behavior changed in R2016a

Prior to R2016a, `tunablePID` was called `ltiblock.pid`.

See Also

`tunablePID2` | `tunableGain` | `tunableTF` | `tunableSS` | `systune` | `looptune` | `genss` | `hinfstruct`

Topics

“Control Design Blocks”

“Models with Tunable Coefficients”

tunablePID2

Tunable two-degree-of-freedom PID controller

Syntax

```
blk = tunablePID2(name,type)
blk = tunablePID2(name,type,Ts)
blk = tunablePID2(name,sys)
```

Description

Model object for creating tunable two-degree-of-freedom PID controllers. `tunablePID2` lets you parametrize a tunable SISO two-degree-of-freedom PID controller. You can use this parametrized controller for parameter studies or for automatic tuning with tuning commands such as `systemtune`, `looptune`, or the Robust Control Toolbox command `hinfstruct`.

`tunablePID2` is part of the family of parametric Control Design Blocks. Other parametric Control Design Blocks include `tunableGain`, `tunableSS`, and `tunableTF`.

Construction

`blk = tunablePID2(name,type)` creates the two-degree-of-freedom continuous-time PID controller described by the equation:

$$u = K_p(br - y) + \frac{K_i}{s}(r - y) + \frac{K_d s}{1 + T_f s}(cr - y).$$

r is the setpoint command, y is the measured response to that setpoint, and u is the control signal, as shown in the following illustration.



The tunable parameters of the block are:

- Scalar gains K_p , K_i , and K_d
- Filter time constant T_f
- Scalar weights b and c

The `type` argument sets the controller type by fixing some of these values to zero (see “Input Arguments” on page 2-1429).

`blk = tunablePID2(name,type,Ts)` creates a discrete-time PID controller with sample time T_s . The equation describing this controller is:

$$u = K_p(br - y) + K_i IF(z)(r - y) + \frac{K_d}{T_f + DF(z)}(cr - y).$$

$IF(z)$ and $DF(z)$ are the discrete integrator formulas for the integral and derivative terms, respectively. The values of the `IFormula` and `DFormula` properties set the discrete integrator formulas (see “Properties” on page 2-1429).

`blk = tunablePID2(name, sys)` uses the dynamic system model, `sys`, to set the sample time, T_s , and the initial values of all the tunable parameters. The model `sys` must be compatible with the equation of a two-degree-of-freedom PID controller.

Input Arguments

name

PID controller Name, specified as a character vector such as 'C' or '2DOFPID1'. (See “Properties” on page 2-1429.)

type

Controller type, specified as one of the values in the following table. Specifying a controller type fixes up to three of the PID controller parameters.

Value for type	Controller Type	Effect on PID Parameters
'P'	Proportional only	Ki and Kd are fixed to zero; Tf is fixed to 1; Kp is free
'PI'	Proportional-integral	Kd is fixed to zero; Tf is fixed to 1; Kp and Ki are free
'PD'	Proportional-derivative with first-order filter on derivative action	Ki is fixed to zero; Kp, Kd, and Tf are free
'PID'	Proportional-integral-derivative with first-order filter on derivative action	Kp, Ki, Kd, and Tf are free

Ts

Sample time, specified as a scalar.

sys

Dynamic system model representing a two-degree-of-freedom PID controller.

Properties

Kp, Ki, Kd, Tf, b, c

Parametrization of the PID gains K_p , K_i , K_d , the filter time constant, T_f , and the scalar gains, b and c .

The following fields of `blk.Kp`, `blk.Ki`, `blk.Kd`, `blk.Tf`, `blk.b`, and `blk.c` are used when you tune `blk` using a tuning command such as `systune`:

Field	Description
Value	Current value of the parameter. <code>blk.b.Value</code> , and <code>blk.c.Value</code> are always nonnegative.
Free	Logical value determining whether the parameter is fixed or tunable. For example: <ul style="list-style-type: none"> If <code>blk.Kp.Free = 1</code>, then <code>blk.Kp.Value</code> is tunable. If <code>blk.Kp.Free = 0</code>, then <code>blk.Kp.Value</code> is fixed.
Minimum	Minimum value of the parameter. This property places a lower bound on the tuned value of the parameter. For example, setting <code>blk.Kp.Minimum = 0</code> ensures that <code>Kp</code> remains positive. <code>blk.Tf.Minimum</code> must always be positive.
Maximum	Maximum value of the parameter. This property places an upper bound on the tuned value of the parameter. For example, setting <code>blk.c.Maximum = 1</code> ensures that <code>c</code> does not exceed unity.

`blk.Kp`, `blk.Ki`, `blk.Kd`, `blk.Tf`, `blk.b`, and `blk.c` are `param.Continuous` objects. For more information about the properties of these `param.Continuous` objects, see the `param.Continuous` object reference page.

IFormula, DFormula

Discrete integrator formulas $IF(z)$ and $DF(z)$ for the integral and derivative terms, respectively, specified as one of the values in the following table.

Value	IF(z) or DF(z) Formula
'ForwardEuler'	$\frac{T_s}{z-1}$
'BackwardEuler'	$\frac{T_s z}{z-1}$
'Trapezoidal'	$\frac{T_s z + 1}{2 z - 1}$

Default: 'ForwardEuler'

Ts

Sample time. For continuous-time models, $T_s = 0$. For discrete-time models, T_s is a positive scalar representing the sampling period. This value is expressed in the unit specified by the `TimeUnit` property of the model. Unspecified sample time ($T_s = -1$) is not supported for PID blocks.

Changing this property does not discretize or resample the model.

Default: 0 (continuous time)

TimeUnit

Units for the time variable, the sample time T_s , and any time delays in the model, specified as one of the following values:

- 'nanoseconds'
- 'microseconds'
- 'milliseconds'
- 'seconds'
- 'minutes'
- 'hours'
- 'days'
- 'weeks'
- 'months'
- 'years'

Changing this property has no effect on other properties, and therefore changes the overall system behavior. Use `chgTimeUnit` to convert between time units without modifying system behavior.

Default: 'seconds'

InputName

Input channel name, specified as a character vector or a 2-by-1 cell array of character vectors. Use this property to name the input channels of the controller model. For example, assign the names `setpoint` and `measurement` to the inputs of a 2-DOF PID controller model `C` as follows.

```
C.InputName = {'setpoint'; 'measurement'};
```

Alternatively, use automatic vector expansion to assign both input names. For example:

```
C.InputName = 'C-input';
```

The input names automatically expand to `{'C-input(1)'; 'C-input(2)'}`.

You can use the shorthand notation `u` to refer to the `InputName` property. For example, `C.u` is equivalent to `C.InputName`.

Input channel names have several uses, including:

- Identifying channels on model display and plots
- Specifying connection points when interconnecting models

Default: {' '; ' '}

InputUnit

Input channel units, specified as a 2-by-1 cell array of character vectors. Use this property to track input signal units. For example, assign the units `Volts` to the reference input and the concentration units `mol/m^3` to the measurement input of a 2-DOF PID controller model `C` as follows.

```
C.InputUnit = {'Volts'; 'mol/m^3'};
```

`InputUnit` has no effect on system behavior.

Default: `{ '' ; '' }`

InputGroup

Input channel groups. This property is not needed for PID controller models.

Default: struct with no fields

OutputName

Output channel name, specified as a character vector. Use this property to name the output channel of the controller model. For example, assign the name `control` to the output of a controller model `C` as follows.

```
C.OutputName = 'control';
```

You can use the shorthand notation `y` to refer to the `OutputName` property. For example, `C.y` is equivalent to `C.OutputName`.

Input channel names have several uses, including:

- Identifying channels on model display and plots
- Specifying connection points when interconnecting models

Default: Empty character vector, `''`

OutputUnit

Output channel units, specified as a character vector. Use this property to track output signal units. For example, assign the unit `Volts` to the output of a controller model `C` as follows.

```
C.OutputUnit = 'Volts';
```

`OutputUnit` has no effect on system behavior.

Default: Empty character vector, `''`

OutputGroup

Output channel groups. This property is not needed for PID controller models.

Default: struct with no fields

Name

System name, specified as a character vector. For example, `'system_1'`.

Default: `''`

Notes

Any text that you want to associate with the system, stored as a string or a cell array of character vectors. The property stores whichever data type you provide. For instance, if `sys1` and `sys2` are dynamic system models, you can set their `Notes` properties as follows:

```

sys1.Notes = "sys1 has a string.";
sys2.Notes = 'sys2 has a character vector.';
sys1.Notes
sys2.Notes

```

```
ans =
```

```
"sys1 has a string."
```

```
ans =
```

```
'sys2 has a character vector.'
```

Default: [0×1 string]

UserData

Any type of data you want to associate with system, specified as any MATLAB data type.

Default: []

Examples

Tunable Two-Degree-of-Freedom Controller with a Fixed Parameter

Create a tunable two-degree-of-freedom PD controller. Then, initialize the parameter values, and fix the filter time constant.

```

blk = tunablePID2('pblock','PD');
blk.b.Value = 1;
blk.c.Value = 0.5;
blk.Tf.Value = 0.01;
blk.Tf.Free = false;
blk

```

```
blk =
```

```
Parametric continuous-time 2-DOF PID controller "pblock" with equation:
```

$$u = K_p (b*r-y) + K_d \frac{s}{T_f*s+1} (c*r-y)$$

where r,y are the controller inputs and K_p, K_d, b, c are tunable gains.

Type "showBlockValue(blk)" to see the current value and "get(blk)" to see all properties.

Controller Initialized by Dynamic System Model

Create a tunable two-degree-of-freedom PI controller. Use a two-input, one-output tf model to initialize the parameters and other properties.

```

s = tf('s');
Kp = 10;
Ki = 0.1;
b = 0.7;

```

```
sys = [(b*Kp + Ki/s), (-Kp - Ki/s)];
blk = tunablePID2('PI2dof',sys)
```

```
blk =
```

```
Parametric continuous-time 2-DOF PID controller "PI2dof" with equation:
```

$$u = K_p (b*r-y) + K_i \frac{1}{s} (r-y)$$

```
where r,y are the controller inputs and Kp, Ki, b are tunable gains.
```

```
Type "showBlockValue(blk)" to see the current value and "get(blk)" to see all
properties.
```

`blk` takes initial parameter values from `sys`.

If `sys` is a discrete-time system, `blk` takes the value of properties, such as `Ts` and `IFormula`, from `sys`.

Controller with Named Inputs and Output

Create a tunable PID controller, and assign names to the inputs and output.

```
blk = tunablePID2('pidblock','pid');
blk.InputName = {'reference','measurement'};
blk.OutputName = {'control'};
```

`blk.InputName` is a cell array containing two names, because a two-degree-of-freedom PID controller has two inputs.

Tips

- You can modify the PID structure by fixing or freeing any of the parameters. For example, `blk.Tf.Free = false` fixes `Tf` to its current value.
- To convert a `tunablePID2` parametric model to a numeric (nontunable) model object, use model commands such as `tf` or `ss`. You can also use `getValue` to obtain the current value of a tunable model.

Version History

Introduced in R2016a

Name changed from `ltiblock.pid2`

Behavior changed in R2016a

Prior to R2016a, `tunablePID2` was called `ltiblock.pid2`.

See Also

`tunablePID` | `tunableGain` | `tunableTF` | `tunableSS` | `system` | `looptune` | `genss` | `hinfstruct`

Topics

“Control Design Blocks”

“Models with Tunable Coefficients”

tunableSS

Tunable fixed-order state-space model

Syntax

```
blk = tunableSS(name,Nx,Ny,Nu)
blk = tunableSS(name,Nx,Ny,Nu,Ts)
blk = tunableSS(name,sys)
blk = tunableSS(...,Astruct)
```

Description

Model object for creating tunable fixed-order state-space models. `tunableSS` lets you parametrize a state-space model of a given order for parameter studies or for automatic tuning with tuning commands such as `systune` or `looptune`.

`tunableSS` is part of the Control Design Block family of parametric models. Other Control Design Blocks include `tunablePID`, `tunableGain`, and `tunableTF`.

Construction

`blk = tunableSS(name,Nx,Ny,Nu)` creates the continuous-time parametric state-space model named `name`. The state-space model `blk` has `Nx` states, `Ny` outputs, and `Nu` inputs. The tunable parameters are the entries in the A , B , C , and D matrices of the state-space model.

`blk = tunableSS(name,Nx,Ny,Nu,Ts)` creates a discrete-time parametric state-space model with sample time `Ts`.

`blk = tunableSS(name,sys)` uses the dynamic system `sys` to dimension the parametric state-space model, set its sample time, and initialize the tunable parameters.

`blk = tunableSS(...,Astruct)` creates a parametric state-space model whose A matrix is restricted to the structure specified in `Astruct`.

Input Arguments

name

Parametric state-space model `Name`, specified as a character vector such as `'C0'`. (See “Properties” on page 2-1436.)

Nx

Nonnegative integer specifying the number of states (order) of the parametric state-space model `blk`.

Ny

Nonnegative integer specifying the number of outputs of the parametric state-space model `blk`.

Nu

Nonnegative integer specifying the number of inputs of the parametric state-space model `blk`.

Ts

Scalar sample time.

Astruct

Constraints on the form of the A matrix of the parametric state-space model `blk`, specified as one of the following values:

Value for Astruct	Structure of A matrix
'tridiag'	A is tridiagonal. In tridiagonal form, A has free elements only in the main diagonal, the first diagonal below the main diagonal, and the first diagonal above the main diagonal. The remaining elements of A are fixed to zero.
'full'	A is full (every entry in A is a free parameter).
'companion'	A is in companion form. In companion form, the characteristic polynomial of the system appears explicitly in the rightmost column of the A matrix. See <code>canon</code> for more information.

If you do not specify **Astruct**, `blk` defaults to 'tridiag' form.

sys

Dynamic system model providing number of states, number of inputs and outputs, sample time, and initial values of the parameters of `blk`. To obtain the dimensions and initial parameter values, `tunableSS` converts `sys` to a state-space model with the structure specified in **Astruct**. If you omit **Astruct**, `tunableSS` converts `sys` into tridiagonal state-space form.

Properties**A, B, C, D**

Parametrization of the state-space matrices A , B , C , and D of the tunable state-space model `blk`.

`blk.A`, `blk.B`, `blk.C`, and `blk.D` are `param.Continuous` objects. For general information about the properties of these `param.Continuous` objects, see the `param.Continuous` object reference page.

The following fields of `blk.A`, `blk.B`, `blk.C`, and `blk.D` are used when you tune `blk` using `hinfstruct`:

Field	Description
Value	<p>Current values of the entries in the parametrized state-space matrix. For example, <code>blk.A.Value</code> contains the values of the A matrix of <code>blk</code>.</p> <p><code>hinfstruct</code> tunes all entries in <code>blk.A.Value</code>, <code>blk.B.Value</code>, <code>blk.C.Value</code>, and <code>blk.D.Value</code> except those whose values are fixed by <code>blk.Gain.Free</code>.</p>
Free	<p>2-D array of logical values determining whether the corresponding state-space matrix parameters are fixed or free parameters. For example:</p> <ul style="list-style-type: none"> • If <code>blk.A.Free(i,j) = 1</code>, then <code>blk.A.Value(i,j)</code> is a tunable parameter. • If <code>blk.A.Free(i,j) = 0</code>, then <code>blk.A.Value(i,j)</code> is fixed. <p>Defaults: By default, all entries in B, C, and D are tunable. The default free entries in A depend upon the value of <code>Astruct</code>:</p> <ul style="list-style-type: none"> • 'tridiag' — entries on the three diagonals of <code>blk.A.Free</code> are 1; the rest are 0. • 'full' — all entries in <code>blk.A.Free</code> are 0. • 'companion' — <code>blk.A.Free(1,:) = 1</code> and <code>blk.A.Free(j,j-1) = 1</code>; all other entries are 0.
Minimum	<p>Minimum value of the parameter. This property places a lower bound on the tuned value of the parameter. For example, setting <code>blk.A.Minimum(1,1) = 0</code> ensures that the first entry in the A matrix remains positive.</p> <p>Default: <code>-Inf</code></p>
Maximum	<p>Maximum value of the parameter. This property places an upper bound on the tuned value of the parameter. For example, setting <code>blk.A.Maximum(1,1) = 0</code> ensures that the first entry in the A matrix remains negative.</p> <p>Default: <code>Inf</code></p>

StateName

State names, specified as one of the following:

- Character vector — For first-order models, for example, 'velocity'.
- Cell array of character vectors — For models with two or more states
- '' — For unnamed states.

Default: '' for all states

StateUnit

State units, specified as one of the following:

- Character vector — For first-order models, for example, 'velocity'
- Cell array of character vectors — For models with two or more states
- '' — For states without specified units

Use `StateUnit` to keep track of the units each state is expressed in. `StateUnit` has no effect on system behavior.

Default: '' for all states

Ts

Sample time. For continuous-time models, $T_s = 0$. For discrete-time models, T_s is a positive scalar representing the sampling period. This value is expressed in the unit specified by the `TimeUnit` property of the model. To denote a discrete-time model with unspecified sample time, set $T_s = -1$.

Changing this property does not discretize or resample the model.

Default: 0 (continuous time)

TimeUnit

Units for the time variable, the sample time T_s , and any time delays in the model, specified as one of the following values:

- 'nanoseconds'
- 'microseconds'
- 'milliseconds'
- 'seconds'
- 'minutes'
- 'hours'
- 'days'
- 'weeks'
- 'months'
- 'years'

Changing this property has no effect on other properties, and therefore changes the overall system behavior. Use `chgTimeUnit` to convert between time units without modifying system behavior.

Default: 'seconds'

InputName

Input channel names, specified as one of the following:

- Character vector — For single-input models, for example, 'controls'.

- Cell array of character vectors — For multi-input models.

Alternatively, use automatic vector expansion to assign input names for multi-input models. For example, if `sys` is a two-input model, enter:

```
sys.InputName = 'controls';
```

The input names automatically expand to `{'controls(1)'; 'controls(2)'}`.

You can use the shorthand notation `u` to refer to the `InputName` property. For example, `sys.u` is equivalent to `sys.InputName`.

Input channel names have several uses, including:

- Identifying channels on model display and plots
- Extracting subsystems of MIMO systems
- Specifying connection points when interconnecting models

Default: '' for all input channels

InputUnit

Input channel units, specified as one of the following:

- Character vector — For single-input models, for example, 'seconds'.
- Cell array of character vectors — For multi-input models.

Use `InputUnit` to keep track of input signal units. `InputUnit` has no effect on system behavior.

Default: '' for all input channels

InputGroup

Input channel groups. The `InputGroup` property lets you assign the input channels of MIMO systems into groups and refer to each group by name. Specify input groups as a structure. In this structure, field names are the group names, and field values are the input channels belonging to each group. For example:

```
sys.InputGroup.controls = [1 2];
sys.InputGroup.noise = [3 5];
```

creates input groups named `controls` and `noise` that include input channels 1, 2 and 3, 5, respectively. You can then extract the subsystem from the `controls` inputs to all outputs using:

```
sys(:, 'controls')
```

Default: Struct with no fields

OutputName

Output channel names, specified as one of the following:

- Character vector — For single-output models. For example, 'measurements'.
- Cell array of character vectors — For multi-output models.

Alternatively, use automatic vector expansion to assign output names for multi-output models. For example, if `sys` is a two-output model, enter:

```
sys.OutputName = 'measurements';
```

The output names automatically expand to `{'measurements(1)'; 'measurements(2)'}`.

You can use the shorthand notation `y` to refer to the `OutputName` property. For example, `sys.y` is equivalent to `sys.OutputName`.

Output channel names have several uses, including:

- Identifying channels on model display and plots
- Extracting subsystems of MIMO systems
- Specifying connection points when interconnecting models

Default: `''` for all output channels

OutputUnit

Output channel units, specified as one of the following:

- Character vector — For single-output models. For example, `'seconds'`.
- Cell array of character vectors — For multi-output models.

Use `OutputUnit` to keep track of output signal units. `OutputUnit` has no effect on system behavior.

Default: `''` for all output channels

OutputGroup

Output channel groups. The `OutputGroup` property lets you assign the output channels of MIMO systems into groups and refer to each group by name. Specify output groups as a structure. In this structure, field names are the group names, and field values are the output channels belonging to each group. For example:

```
sys.OutputGroup.temperature = [1];  
sys.InputGroup.measurement = [3 5];
```

creates output groups named `temperature` and `measurement` that include output channels 1, and 3, 5, respectively. You can then extract the subsystem from all inputs to the measurement outputs using:

```
sys('measurement', :)
```

Default: Struct with no fields

Name

System name, specified as a character vector. For example, `'system_1'`.

Default: `''`

Notes

Any text that you want to associate with the system, stored as a string or a cell array of character vectors. The property stores whichever data type you provide. For instance, if `sys1` and `sys2` are dynamic system models, you can set their `Notes` properties as follows:

```
sys1.Notes = "sys1 has a string.";
sys2.Notes = 'sys2 has a character vector.';
sys1.Notes
sys2.Notes
```

```
ans =
```

```
    "sys1 has a string."
```

```
ans =
```

```
    'sys2 has a character vector.'
```

Default: [0×1 string]

UserData

Any type of data you want to associate with system, specified as any MATLAB data type.

Default: []

Examples

Create a parametrized 5th-order SISO model with zero D matrix.

```
blk = tunableSS('ssblock',5,1,1);
blk.D.Value = 0;      % set D = 0
blk.D.Free = false;  % fix D to zero
```

By default, the A matrix is in tridiagonal form. To parametrize the model in companion form, use the `'companion'` input argument:

```
blk = tunableSS('ssblock',5,1,1,'companion');
blk.D.Value = 0;      % set D = 0
blk.D.Free = false;  % fix D to zero
```

Create a parametric state-space model, and assign names to the inputs.

```
blk = tunableSS('ssblock',5,2,2) % 5 states, 2 outputs, 2 inputs
blk.InputName = {'Xerror','Yerror'} % assign input names
```

Tips

- Use the `Astruct` input argument to constrain the structure of the A matrix of the parametric state-space model. To impose additional structure constraints on the state-space matrices, use the fields `blk.A.Free`, `blk.B.Free`, `blk.C.Free`, and `blk.D.Free` to fix the values of specific entries in the parameter matrices.

For example, to fix the value of `blk.B(i,j)`, set `blk.B.Free(i,j) = 0`. To allow `hinfstruct` to tune `blk.B(i,j)`, set `blk.B.Free(i,j) = 1`.

- To convert a `tunableSS` parametric model to a numeric (non-tunable) model object, use model commands such as `ss`, `tf`, or `zpk`.

Version History

Introduced in R2016a

Name changed from `ltiblock.ss`

Behavior changed in R2016a

Prior to R2016a, `tunableSS` was called `ltiblock.ss`.

See Also

`tunablePID` | `tunablePID2` | `tunableGain` | `tunableTF` | `systune` | `looptune` | `genss` | `hinfstruct`

Topics

“Control Design Blocks”

“Models with Tunable Coefficients”

tunableSurface

Create tunable gain surface for gain scheduling

Syntax

```
K = tunableSurface(name,K0init,domain,shapefcn)
K = tunableSurface(name,K0init,domain)
```

Description

`tunableSurface` lets you parameterize and tune gain schedules, which are gains that vary as a function of one or more scheduling variables.

For tuning purposes, it is convenient to parameterize a variable gain as a smooth gain surface of the form:

$$K(n(\sigma)) = \gamma[K_0 + K_1F_1(n(\sigma)) + \dots + K_MF_M(n(\sigma))],$$

where

- σ is a vector of scheduling variables.
- $n(\sigma)$ is a normalization function (see the `Normalization` property of the output argument `K`).
- γ is a scaling factor (see the `Normalization` property of the output argument `K`).
- F_1, \dots, F_M are user-selected basis functions.
- K_0, \dots, K_M are the coefficients to be tuned

You can use terms in a generic polynomial expansion as basis functions. Or, when the expected shape of $K(\sigma)$ is known, you can use more specific functions. You can then use `systemtune` to tune the coefficients K_0, \dots, K_M , subject to your design requirements, over the range of scheduling-variable values.

`K = tunableSurface(name,K0init,domain,shapefcn)` creates the tunable gain surface:

$$K(n(\sigma)) = \gamma[K_0 + K_1F_1(n(\sigma)) + \dots + K_MF_M(n(\sigma))].$$

The tunable surface `K` stores the basis functions specified by `shapefcn` and a discrete set of σ values (the design points) given by `domain`. The tunable gain surface has tunable coefficients K_0, \dots, K_M . The gain value is initialized to the constant gain `K0init`. You can combine `K` with other static or dynamic elements to construct a closed-loop model of your gain-scheduled control system. Or, use `K` to parameterize a lookup table in an `sLTuner` interface to a Simulink model. Then, use `systemtune` to tune K_0, \dots, K_M so that the closed-loop system meets your design requirements at the selected design points.

`K = tunableSurface(name,K0init,domain)` creates a flat surface with constant, tunable gain. This syntax is equivalent to `tunableGain(name,K0init)`.

Examples

Tunable Gain With One Scheduling Variable

Create a scalar gain K that varies as a quadratic function of t :

$$K(t) = K_0 + K_1n(t) + K_2(n(t))^2.$$

This gain surface can represent a gain that varies with time. The coefficients K_0 , K_1 , and K_2 are the tunable parameters of this time-varying gain. For this example, suppose that t varies from 0 to 40. In that case, the normalization function is $n(t) = (t - 20)/20$.

To represent the tunable gain surface $K(t)$ in MATLAB®, first choose a vector of t values that are the design points of your system. For example, if your design points are snapshots of a time-varying system every 5 seconds from times $t = 0$ to $t = 40$, use the following sampling grid:

```
t = 0:5:40;
domain = struct('t',t);
```

Specify a quadratic function for the variable gain.

```
shapefcn = @(x) [x,x^2];
```

`shapefcn` is the handle to an anonymous vector function. Each entry in the vector gives a term in the polynomial expansion that describes the variable gain. `tunableSurface` implicitly assumes the constant function $f_0(t) = 1$, so it need not be included in `shapefcn`.

Create the tunable gain surface $K(t)$.

```
K = tunableSurface('K',1,domain,shapefcn)

K =
Tunable surface "K" of scalar gains with:
* Scheduling variables: t
* Basis functions: t,t^2
* Design points: 1x9 grid of t values
* Normalization: default (from design points)
```

The display summarizes the characteristics of the gain surface, including the design points and the basis functions. Examine the properties of K .

```
get(K)

BasisFunctions: @(x)[x,x^2]
Coefficients: [1x3 realp]
SamplingGrid: [1x1 struct]
Normalization: [1x1 struct]
Name: 'K'
```

The `Coefficients` property of the tunable surface is the array of tunable coefficients, $[K_0, K_1, K_2]$, stored as an array-valued `realp` block.

You can now use the tunable surface in a control system model. For tuning in MATLAB, interconnect K with other control system elements just as you would use a Control Design Block to create a tunable control system model. For tuning in Simulink®, use `setBlockParam` to make K the parameterization of a tunable block in an `sLTuner` interface. When you tune the model or `sLTuner` interface using `systemtune`, the resulting model or interface contains tuned values for the coefficients K_0 , K_1 , and K_2 .

After you tune the coefficients, you can view the shape of the resulting gain curve using the `viewSurf` command. For this example, instead of tuning, manually set the coefficients to non-zero values. View the resulting gain as a function of time.

```
Ktuned = setData(K,[12.1,4.2,2]);
viewSurf(Ktuned)
```

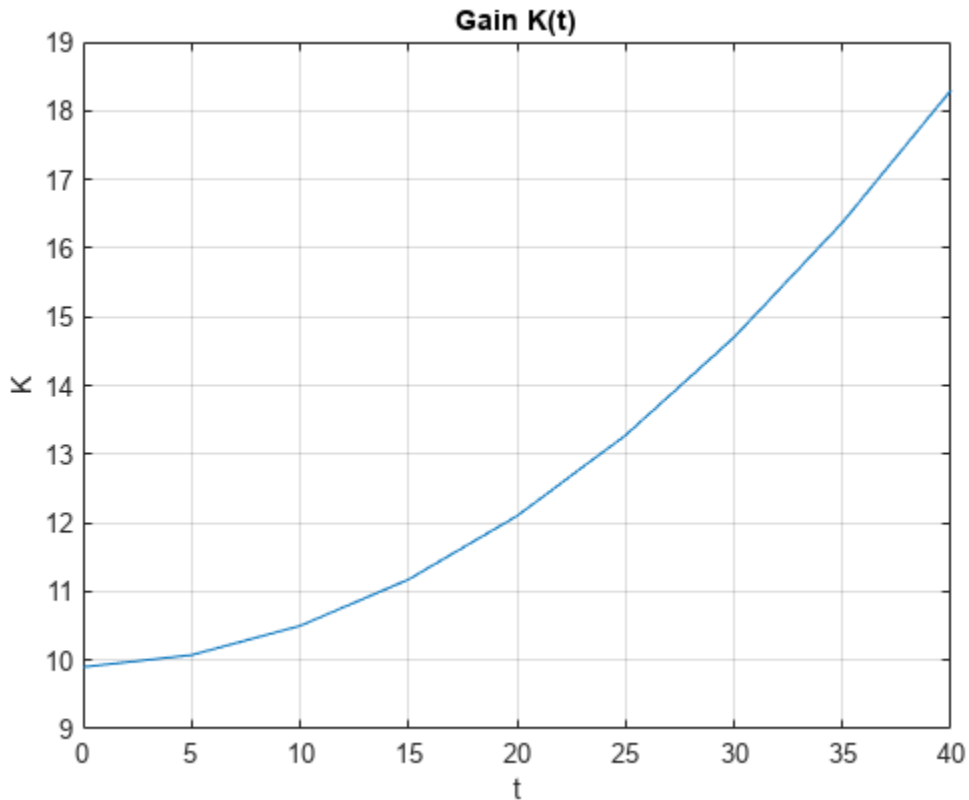

`viewSurf` displays the gain as a function of the scheduling variable, for the range of scheduling-variable values specified by `domain` and stored in the `SamplingGrid` property of the gain surface.

Tunable Gain with Two Independent Scheduling Variables

This example shows how to model a scalar gain K with a bilinear dependence on two scheduling variables. You do so by creating a grid of design points representing the independent dependence of the two variables.

Suppose that the first variable α is an angle of incidence that ranges from 0 to 15 degrees, and the second variable V is a speed that ranges from 300 to 600 m/s. By default, the normalized variables are:

$$x = \frac{\alpha - 7.5}{7.5}, \quad y = \frac{V - 450}{150}.$$

The gain surface is modeled as:

$$K(\alpha, V) = K_0 + K_1x + K_2y + K_3xy,$$

where K_0, \dots, K_3 are the tunable parameters.

Create a grid of design points, (α, V) , that are linearly spaced in α and V . These design points are the scheduling-variable values used for tuning the gain-surface coefficients. They must correspond to parameter values at which you have sampled the plant.

```
[alpha,V] = ndgrid(0:3:15,300:50:600);
```

These arrays, `alpha` and `V`, represent the independent variation of the two scheduling variables, each across its full range. Put them into a structure to define the design points for the tunable surface.

```
domain = struct('alpha',alpha,'V',V);
```

Create the basis functions that describe the bilinear expansion.

```
shapefcn = @(x,y) [x,y,x*y]; % or use polyBasis('canonical',1,2)
```

In the array returned by `shapefcn`, the basis functions are:

$$F_1(x, y) = x$$

$$F_2(x, y) = y$$

$$F_3(x, y) = xy.$$

Create the tunable gain surface.

```
K = tunableSurface('K',1,domain,shapefcn);
```

You can use the tunable surface as the parameterization for a lookup table block or a MATLAB Function block in a Simulink model. Or, use model interconnection commands to incorporate it as a tunable element in a control system modeled in MATLAB. After you tune the coefficients, you can examine the resulting gain surface using the `viewSurf` command. For this example, instead of tuning, manually set the coefficients to non-zero values and view the resulting gain.

```
Ktuned = setData(K,[100,28,40,10]);  
viewSurf(Ktuned)
```

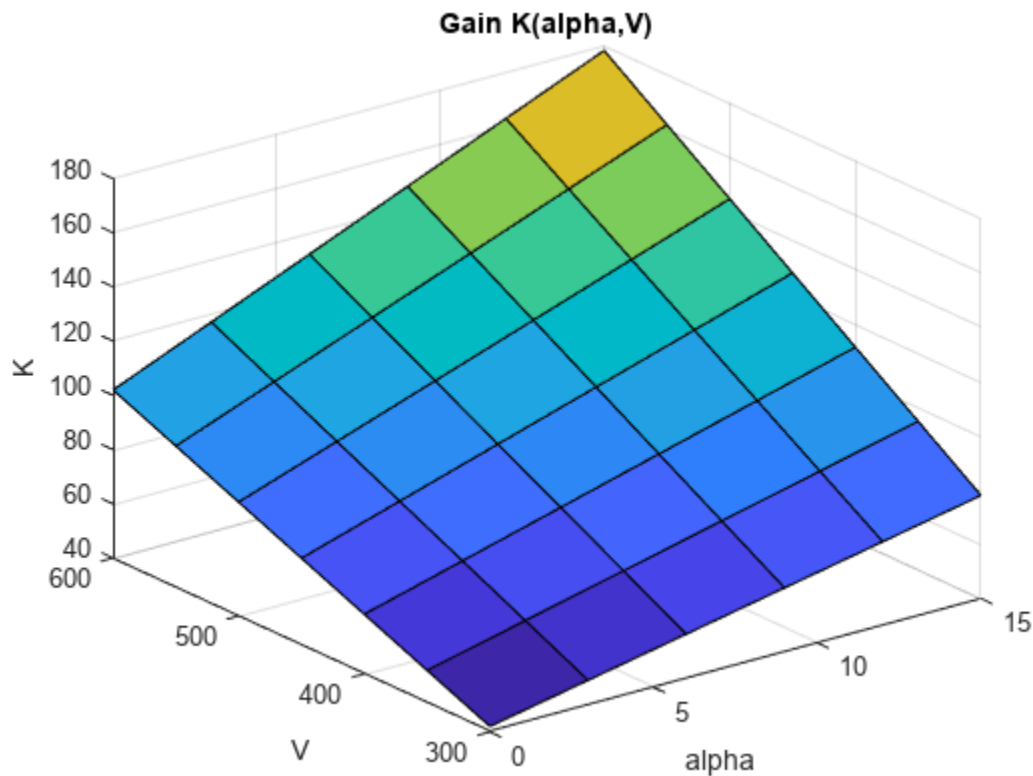
`viewSurf` displays the gain surface as a function of the scheduling variables, for the ranges of values specified by `domain` and stored in the `SamplingGrid` property of the gain surface.

Gain Surface Over Nonregular Grid

Create a gain surface using design points that do not form a regular grid in the operating domain. The gain surface varies as a bilinear function of normalized scheduling variables α_N and β_N :

$$K(\alpha_N, \beta_N) = K_0 + K_1\alpha_N + K_2\beta_N + K_3\alpha_N\beta_N.$$

Suppose that the values of interest of the scheduling variables are the following (α, β) pairs.

$$(\alpha, \beta) = \begin{cases} (-0.9, 0.05) \\ (-1.5, 0.6) \\ (-1.5, 0.95) \\ (-2.5, 0.5) \\ (-3.2, 0.7) \\ (-3.9, 0.3) \end{cases}.$$

Specify the (α, β) sample values as vectors.

```
alpha = [-0.9;-1.5;-1.5;-2.5;-3.2;-3.9];
beta = [0.05;0.6;0.95;0.5;0.7;0.3];
domain = struct('alpha',alpha,'beta',beta);
```

Instead of a regular grid of (α, β) values, here the system is sampled at irregularly spaced points on (α, β) -space.

```
plot(alpha,beta,'o')
```

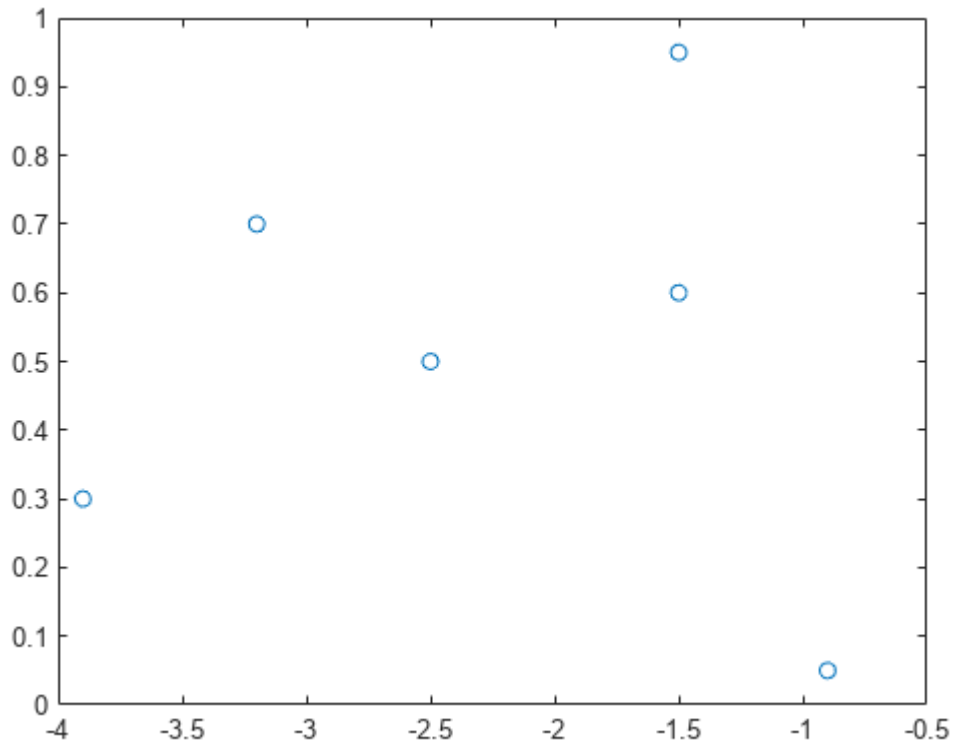

Specify the basis functions.

```
shapefcn = @(x,y) [x,y,x*y];
```

Create the tunable model of the gain surface using these sampled function values.

```
K = tunableSurface('K',1,domain,shapefcn)
```

K =

```
Tunable surface "K" of scalar gains with:
* Scheduling variables: alpha,beta
* Basis functions: alpha,beta,alpha*beta
* Design points: 6x1 grid of (alpha,beta) values
* Normalization: default (from design points)
```

The domain is the list of six (α, β) pairs. The normalization, by default, shifts α and β so that the center of the range of each variable is zero, and scales them so that they range from -1 to 1.

K.Normalization

```
ans = struct with fields:
    InputOffset: [-2.4000 0.5000]
    InputScaling: [1.5000 0.4500]
    OutputScaling: 1
```

Matrix-Valued Tunable Surface

Create a tunable gain surface that takes two scheduling variables and returns a 3-by-3 gain matrix. Each entry in the gain matrix is an independent function of the two scheduling variables.

Create a grid of design points (α, V).

```
[alpha,V] = ndgrid(0:3:15,300:50:600);
domain = struct('alpha',alpha,'V',V);
```

Create the basis function that describes how the surface varies with the scheduling variables. Use a basis that describes a bilinear expansion in α and V .

```
shapefcn = polyBasis('canonical',1,2);
```

To create the tunable surface, specify the initial value of the matrix-valued gain surface. This value sets the value of the gain surface when the normalized scheduling variables are both zero. `tunableSurface` takes the dimensions of the gain surface from the initial value you specify. Thus, to create a 3-by-3 gain matrix, use a 3-by-3 initial value.

```
K0init = diag([0.05 0.05 -0.05]);
K0 = tunableSurface('K',K0init,domain,shapefcn)
```

```
K0 =
Tunable surface "K" of 3x3 gain matrices with:
* Scheduling variables: alpha,V
* Basis functions: @(x1,x2)utFcnBasisOuterProduct(FDATA_,x1,x2)
* Design points: 6x7 grid of (alpha,V) values
* Normalization: default (from design points)
```

Input Arguments

name — Identifying label for the tunable gain

character vector

Identifying label for the tunable gain surface, specified as a character vector. `tunableSurface` uses this name for the `realp` block that represents the tunable coefficients of the surface. Therefore, you can use this name to refer to the tunable gain coefficients within a `genss` model of a control system or an `sLTuner` interface.

K0init — Initial value of constant term

scalar | array

Initial value of the constant term in the tunable gain surface, specified as a scalar or an array. The dimensions of `K0init` determine the I/O dimensions of the gain surface. For example, if the gain surface represents a two-input, two-output gain, you can set `K0init = ones(2)`. The remaining

coefficients K_1, K_2, \dots always have the same size as K_0 . The tunable coefficients automatically expand so that the gains in each I/O channel are tuned independently.

For example, for a two-input, two-output surface, there is a set of expansion coefficients for each entry in the gain matrix.

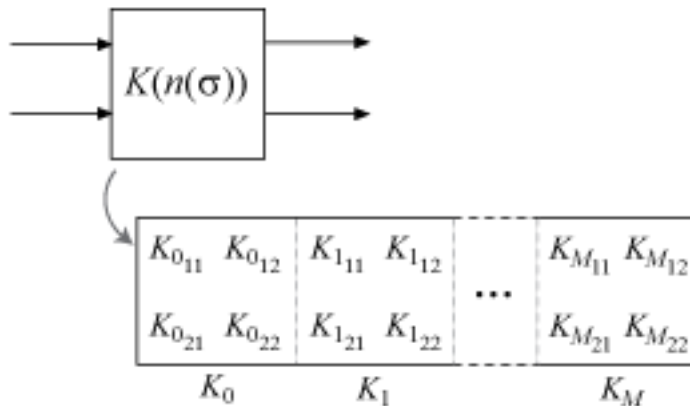

Each entry K_{ij} in the tunable gain matrix $K(n(\sigma))$ is given by:

$$K_{ij}(n(\sigma)) = K_{ij0} + K_{ij1}F_1(n(\sigma)) + \dots + K_{ijM}F_M(n(\sigma)).$$

domain — Design points

structure

Design points at which the gain surface is tuned, specified as a structure. The structure has fields containing the scheduling variables values at which you sample the plant for gain-scheduled tuning. For example, suppose that you want to tune a gain that varies as a function of two scheduling variables, α and V . You linearize the plant at a grid of α and V values, with $\alpha = [0.5, 0.10, 0.15]$ and $V = [700, 800, 900, 1000]$

. Specify the design points as follows:

```
[alpha,V] = ndgrid([0.5,0.10,0.15],[700,800,900,1000]);
domain = struct('alpha',alpha,'V',V);
```

The design points do not have to lie on a rectangular or regularly spaced grid (see “Gain Surface Over Nonregular Grid” on page 2-1447). However, for best results use design points that cover the full range of operating conditions. Since tuning only considers these design points, the validity of the tuned gain schedule is questionable at operating conditions far from the design points.

shapefcn — Basis functions

function handle

Basis functions used to model the gain surface in terms of the scheduling variables, specified as a function handle. The function associated with the handle takes normalized values of the scheduling variables as inputs and returns a vector of basis-function values. The basis functions always operate on the normalized range $[-1, 1]$. `tunableSurface` implicitly normalizes the scheduling variables to this interval.

For example, consider the scheduling-variable values $\alpha = [0.5, 0.10, 0.15]$ and $V = [700, 800, 900, 1000]$. The following expression creates basis functions for a gain surface that is bilinear in these variables:

```
shapefcn = @(x,y) [x y x*y];
```

`shapefcn` is an anonymous function of two variables. The basis functions describe a parameterized gain $G(\alpha, V) = G_0 + G_1\alpha_N + G_2V_N + G_3\alpha_NV_N$ where α_N and V_N are the normalized scheduling variables (see the `Normalization` property of `K`).

You can use anonymous functions to specify any set of basis functions that you need to describe the variable gain. Alternatively, you can use helper functions to generate basis functions automatically for commonly used expansions:

- `polyBasis` — Power series expansion and Chebyshev expansion.
- `fourierBasis` — Periodic Fourier series expansion. The basis functions generated by `fourierBasis` are periodic such that a gain surface K defined by those functions satisfies $K(-1) = K(1)$. When you create a gain surface using `tunableSurface`, the software normalizes the scheduling-variable range that you specify with `domain` to the interval $[-1, 1]$. Therefore, if you use periodic basis functions, then the sampled range of the corresponding scheduling variable must be exactly one period. This restriction ensures that the periodicity of the basis function matches that of the scheduling variable. For example, if the periodically varying scheduling variable is an angle that ranges from 0 to 2π , then the corresponding values in `domain` must also range from 0 to 2π .
- `ndBasis` — Build multidimensional expansions from lower-dimensional expansions. This function is useful when you want to use different basis functions for different scheduling variables.

See the reference pages for those functions for more information about the basis functions they generate.

Output Arguments

K — Tunable gain surface

`tunableSurface` object

Tunable gain surface, returned as a `tunableSurface` object. This object has the following properties that store the coefficients, basis functions, and other information about the gain surface:

- `BasisFunctions` — Basis functions, specified as a function handle. When you create the gain surface, the `shapefcn` input argument sets the initial value of this property.
- `Coefficients` — Tunable coefficients of the gain surface, specified as an array-valued real parameter. The dimensions of `K0init` and the number of basis functions in `shapefcn` determine the dimensions of `K.Coefficients`.

For scalar gains, `K.Coefficients` has dimensions $[1, M+1]$, where M is the number of basis functions. The entries in `K.Coefficients` correspond to the tunable coefficients K_0, \dots, K_M .

For array-valued gains, each coefficient expands to the dimension of `K0init`. These expanded coefficients are concatenated horizontally in `K.Coefficients`. Therefore, for example, for a two-input, two-output gain surface, `K.Coefficients` has dimensions $[2, 2(M+1)]$.

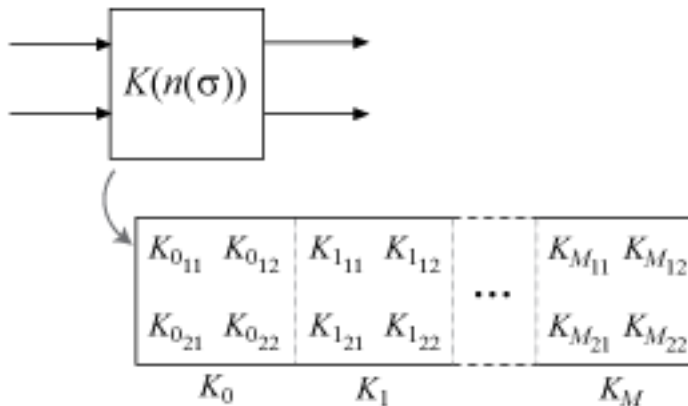

Each entry K_{ij} in the tunable gain matrix $K(n(\sigma))$ is given by:

$$K_{ij}(n(\sigma)) = K_{ij0} + K_{ij1}F_1(n(\sigma)) + \dots + K_{ijM}F_M(n(\sigma)).$$

- **SamplingGrid** — Grid of design points, specified as a data structure. When you create the gain surface, the domain input argument sets the initial value of this property.
- **Normalization** — Normalization offset and scaling, specified as a structure with fields:
 - **InputOffset** — Vector of offsets for each scheduling variable.
 - **InputScaling** — Vector of scaling factors for each scheduling variable.
 - **OutputScaling** — Scaling factor for overall gain.

In general, the `tunableSurface` parameterization takes the form:

$$K(\sigma) = \text{OutputScaling}[K_0 + K_1F_1(n(\sigma)) + \dots + K_mF_m(n(\sigma))],$$

where $n(\sigma)$ is the normalized scheduling variable, given by:

$$n(\sigma) = \frac{\sigma - \text{InputOffset}}{\text{InputScaling}}.$$

`tunableSurface` normalizes the scheduling variables to compress their numerical range and improve the numerical stability of the optimization process. By default, **OutputScaling** = 1, and `tunableSurface` computes values for **InputOffset** and **InputScaling** that map the **SamplingGrid** domain of each scheduling variable to [-1,1]. Thus, $n = 0$ at the center of the design-point range.

You can change the default normalization by adjusting the values of these fields. For example:

- If you have a known gain value for a particular design point, you can set **Normalization.InputOffset** so that $n = 0$ at that design point. You can then set **K0init** to the known gain value.
- If you want to restrict a scheduling variable to nonnegative values, set **Normalization.InputOffset** to the minimum value of that variable in your design grid. This restriction is useful, for example, when your basis function includes $\sqrt{\sigma}$.
- **Name** — Name of the gain surface, specified as a character vector. When you create the gain surface, the name input argument sets the initial value of this property.

Tips

- To tune a gain surface in a control system modeled in MATLAB: Connect the gain surface with an array of plant models corresponding to the design points in `domain`. For example, suppose `G` is such an array, and `K` represents a variable integration time. The following command builds a closed-loop model that you can tune with the `system` command.

```
C0 = tf(K,[1 0]);  
T0 = feedback(C0*G,1);
```

- To tune a gain surface in a control system modeled in Simulink: Use the gain surface to parameterize a lookup-table, matrix interpolation, or MATLAB function block in the Simulink model. For example, suppose `ST0` is an `slTuner` interface to a Simulink model, and `GainTable` is the name of a tuned block in the interface. The following command sets the parameterization of `GainTable` to the tunable gain surface.

```
ST0 = setBlockParam(ST0,'GainTable',K);
```

See “Parameterize Gain Schedules” for more information.

- When you use `writeBlockValue` to write a tuned gain surface back to a Simulink model, the software uses `codegen` to generate MATLAB code for the gain surface. You can use `codegen` yourself to examine this code.

Version History

Introduced in R2015b

See Also

Functions

`codegen` | `ndgrid` | `viewSurf` | `evalSurf` | `system` | `polyBasis` | `fourierBasis` | `ndBasis`

Topics

“Parameterize Gain Schedules”

“Gain Scheduling Basics”

“Tuning of Gain-Scheduled Three-Loop Autopilot”

tunableTF

Tunable transfer function with fixed number of poles and zeros

Syntax

```
blk = tunableTF(name,Nz,Np)
blk = tunableTF(name,Nz,Np,Ts)
blk = tunableTF(name,sys)
```

Description

Model object for creating tunable SISO transfer function models of fixed order. `tunableTF` lets you parameterize a transfer function of a given order for parameter studies or for automatic tuning with tuning commands such as `sys tune` or `looptune`.

`tunableTF` is part of the Control Design Block family of parametric models. Other Control Design Blocks include `tunablePID`, `tunableSS`, and `tunableGain`.

Construction

`blk = tunableTF(name,Nz,Np)` creates the parametric SISO transfer function:

$$blk = \frac{a_m s^m + a_{m-1} s^{m-1} + \dots + a_1 s + a_0}{s^n + b_{n-1} s^{n-1} + \dots + b_1 s + b_0}.$$

$n = Np$ is the maximum number of poles of `blk`, and $m = Nz$ is the maximum number of zeros. The tunable parameters are the numerator and denominator coefficients a_0, \dots, a_m and b_0, \dots, b_{n-1} . The leading coefficient of the denominator is fixed to 1.

`blk = tunableTF(name,Nz,Np,Ts)` creates a discrete-time parametric transfer function with sample time `Ts`.

`blk = tunableTF(name,sys)` uses the `tf` model `sys` to set the number of poles, number of zeros, sample time, and initial parameter values.

Input Arguments

name

Parametric transfer function Name, specified as a character vector such as `'filt'` or `'DM'`. (See “Properties” on page 2-1455.)

Nz

Nonnegative integer specifying the number of zeros of the parametric transfer function `blk`.

Np

Nonnegative integer specifying the number of poles of the parametric transfer function `blk`.

Ts

Scalar sample time.

sys

tf model providing number of poles, number of zeros, sample time, and initial values of the parameters of blk.

Properties**Numerator, Denominator**

Parameterization of the numerator coefficients a_m, \dots, a_0 and the denominator coefficients $1, b_{n-1}, \dots, b_0$ of the tunable transfer function blk.

blk.Numerator and blk.Denominator are param.Continuous objects. For general information about the properties of these param.Continuous objects, see the param.Continuous object reference page.

The following fields of blk.Numerator and blk.Denominator are used when you tune blk using hinfstruct:

Field	Description
Value	<p>Array of current values of the numerator a_m, \dots, a_0 or the denominator coefficients $1, b_{n-1}, \dots, b_0$. blk.Numerator.Value has length Nz + 1. blk.Denominator.Value has length Np + 1. The leading coefficient of the denominator (blk.Denominator.Value(1)) is always fixed to 1.</p> <p>By default, the coefficients initialize to values that yield a stable, strictly proper transfer function. Use the input sys to initialize the coefficients to different values.</p> <p>hinfstruct tunes all values except those whose Free field is zero.</p>
Free	<p>Array of logical values determining whether the coefficients are fixed or tunable. For example:</p> <ul style="list-style-type: none"> • If blk.Numerator.Free(j) = 1, then blk.Numerator.Value(j) is tunable. • If blk.Numerator.Free(j) = 0, then blk.Numerator.Value(j) is fixed. <p>Default: blk.Denominator.Free(1) = 0; all other entries are 1.</p>

Field	Description
Minimum	<p>Minimum value of the parameter. This property places a lower bound on the tuned value of the parameter. For example, setting <code>blk.Numerator.Minimum(1) = 0</code> ensures that the leading coefficient of the numerator remains positive.</p> <p>Default: <code>-Inf</code></p>
Maximum	<p>Maximum value of the parameter. This property places an upper bound on the tuned value of the parameter. For example, setting <code>blk.Numerator.Maximum(1) = 1</code> ensures that the leading coefficient of the numerator does not exceed 1.</p> <p>Default: <code>Inf</code></p>

Ts

Sample time. For continuous-time models, $T_s = 0$. For discrete-time models, T_s is a positive scalar representing the sampling period. This value is expressed in the unit specified by the `TimeUnit` property of the model. To denote a discrete-time model with unspecified sample time, set $T_s = -1$.

Changing this property does not discretize or resample the model.

Default: `0` (continuous time)

TimeUnit

Units for the time variable, the sample time T_s , and any time delays in the model, specified as one of the following values:

- 'nanoseconds'
- 'microseconds'
- 'milliseconds'
- 'seconds'
- 'minutes'
- 'hours'
- 'days'
- 'weeks'
- 'months'
- 'years'

Changing this property has no effect on other properties, and therefore changes the overall system behavior. Use `chgTimeUnit` to convert between time units without modifying system behavior.

Default: 'seconds'

InputName

Input channel names, specified as one of the following:

- Character vector — For single-input models, for example, 'controls'.
- Cell array of character vectors — For multi-input models.

Alternatively, use automatic vector expansion to assign input names for multi-input models. For example, if `sys` is a two-input model, enter:

```
sys.InputName = 'controls';
```

The input names automatically expand to {'controls(1)'; 'controls(2)'}

You can use the shorthand notation `u` to refer to the `InputName` property. For example, `sys.u` is equivalent to `sys.InputName`.

Input channel names have several uses, including:

- Identifying channels on model display and plots
- Extracting subsystems of MIMO systems
- Specifying connection points when interconnecting models

Default: '' for all input channels

InputUnit

Input channel units, specified as one of the following:

- Character vector — For single-input models, for example, 'seconds'.
- Cell array of character vectors — For multi-input models.

Use `InputUnit` to keep track of input signal units. `InputUnit` has no effect on system behavior.

Default: '' for all input channels

InputGroup

Input channel groups. The `InputGroup` property lets you assign the input channels of MIMO systems into groups and refer to each group by name. Specify input groups as a structure. In this structure, field names are the group names, and field values are the input channels belonging to each group. For example:

```
sys.InputGroup.controls = [1 2];
sys.InputGroup.noise = [3 5];
```

creates input groups named `controls` and `noise` that include input channels 1, 2 and 3, 5, respectively. You can then extract the subsystem from the `controls` inputs to all outputs using:

```
sys(:, 'controls')
```

Default: Struct with no fields

OutputName

Output channel names, specified as one of the following:

- Character vector — For single-output models. For example, 'measurements'.
- Cell array of character vectors — For multi-output models.

Alternatively, use automatic vector expansion to assign output names for multi-output models. For example, if `sys` is a two-output model, enter:

```
sys.OutputName = 'measurements';
```

The output names automatically expand to {'measurements(1)'; 'measurements(2)' }.

You can use the shorthand notation `y` to refer to the `OutputName` property. For example, `sys.y` is equivalent to `sys.OutputName`.

Output channel names have several uses, including:

- Identifying channels on model display and plots
- Extracting subsystems of MIMO systems
- Specifying connection points when interconnecting models

Default: '' for all output channels

OutputUnit

Output channel units, specified as one of the following:

- Character vector — For single-output models. For example, 'seconds'.
- Cell array of character vectors — For multi-output models.

Use `OutputUnit` to keep track of output signal units. `OutputUnit` has no effect on system behavior.

Default: '' for all output channels

OutputGroup

Output channel groups. The `OutputGroup` property lets you assign the output channels of MIMO systems into groups and refer to each group by name. Specify output groups as a structure. In this structure, field names are the group names, and field values are the output channels belonging to each group. For example:

```
sys.OutputGroup.temperature = [1];  
sys.InputGroup.measurement = [3 5];
```

creates output groups named `temperature` and `measurement` that include output channels 1, and 3, 5, respectively. You can then extract the subsystem from all inputs to the measurement outputs using:

```
sys('measurement', :)
```

Default: Struct with no fields

Name

System name, specified as a character vector. For example, 'system_1'.

Default: ''

Notes

Any text that you want to associate with the system, stored as a string or a cell array of character vectors. The property stores whichever data type you provide. For instance, if `sys1` and `sys2` are dynamic system models, you can set their `Notes` properties as follows:

```
sys1.Notes = "sys1 has a string.";
sys2.Notes = 'sys2 has a character vector.';
sys1.Notes
sys2.Notes
```

```
ans =
```

```
"sys1 has a string."
```

```
ans =
```

```
'sys2 has a character vector.'
```

Default: [0×1 string]

UserData

Any type of data you want to associate with system, specified as any MATLAB data type.

Default: []

Examples

Create a parametric SISO transfer function with two zeros, four poles, and at least one integrator.

A transfer function with an integrator includes a factor of $1/s$. Therefore, to ensure that a parameterized transfer function has at least one integrator regardless of the parameter values, fix the lowest-order coefficient of the denominator to zero.

```
blk = tunableTF('tfblock',2,4); % two zeros, four poles
blk.Denominator.Value(end) = 0; % set last denominator entry to zero
blk.Denominator.Free(end) = 0; % fix it to zero
```

Create a parametric transfer function, and assign names to the input and output.

```
blk = tunableTF('tfblock',2,3);
blk.InputName = {'error'}; % assign input name
blk.OutputName = {'control'}; % assign output name
```

Tips

- To convert a `tunableTF` parametric model to a numeric (non-tunable) model object, use model commands such as `tf`, `zpk`, or `ss`.

Version History

Introduced in R2016a

Name changed from ltiblock.tf

Behavior changed in R2016a

Prior to R2016a, tunableTF was called ltiblock.tf.

See Also

tunablePID | tunablePID2 | tunableGain | tunableSS | systune | looptune | genss | hinfstruct

Topics

“Control Design Blocks”

“Models with Tunable Coefficients”

tzero

Invariant zeros of linear system

Syntax

```
z = tzero(sys)
z = tzero(A,B,C,D,E)
z = tzero( ____,tol)
[z,nrank] = tzero( ____ )
```

Description

`z = tzero(sys)` returns the invariant zeros on page 2-1464 of the multi-input, multi-output (MIMO) dynamic system, `sys`. If `sys` is a minimal realization, the invariant zeros coincide with the transmission zeros on page 2-1464 of `sys`.

`z = tzero(A,B,C,D,E)` returns the invariant zeros on page 2-1464 of the state-space model

$$E \frac{dx}{dt} = Ax + Bu$$

$$y = Cx + Du.$$

Omit `E` for an explicit state-space model ($E = I$).

`z = tzero(____,tol)` specifies the relative tolerance, `tol`, controlling rank decisions.

`[z,nrank] = tzero(____)` also returns the normal rank of the transfer function of `sys` or of the transfer function $H(s) = D + C(sE - A)^{-1}B$.

Input Arguments

`sys`

MIMO dynamic system model. If `sys` is not a state-space model, then `tzero` computes `tzero(ss(sys))`.

`A, B, C, D, E`

State-space matrices describing the linear system

$$E \frac{dx}{dt} = Ax + Bu$$

$$y = Cx + Du.$$

`tzero` does not scale the state-space matrices when you use the syntax `z = tzero(A,B,C,D,E)`. Use `prescale` if you want to scale the matrices before using `tzero`.

Omit `E` to use $E = I$.

tol

Relative tolerance controlling rank decisions. Increasing tolerance helps detect nonminimal modes and eliminate very large zeros (near infinity). However, increased tolerance might artificially inflate the number of transmission zeros.

Default: $\text{eps}^{(3/4)}$

Output Arguments**z**

Column vector containing the invariant zeros on page 2-1464 of `sys` or the state-space model described by `A, B, C, D, E`.

nrank

Normal rank of the transfer function of `sys` or of the transfer function $H(s) = D + C(sE - A)^{-1}B$. The normal rank is the rank for values of s other than the transmission zeros on page 2-1464.

To obtain a meaningful result for `nrank`, the matrix $s*E - A$ must be regular (invertible for most values of s). In other words, `sys` or the system described by `A, B, C, D, E` must have a finite number of poles.

Examples**Find Transmission Zeros of MIMO Transfer Function**

Create a MIMO transfer function, and locate its invariant zeros.

```
s = tf('s');
H = [1/(s+1) 1/(s+2); 1/(s+3) 2/(s+4)];
z = tzero(H)
```

```
z = 2×1 complex
   -2.5000 + 1.3229i
   -2.5000 - 1.3229i
```

The output is a column vector listing the locations of the invariant zeros of `H`. This output shows that `H` has a complex pair of invariant zeros. Confirm that the invariant zeros coincide with the transmission zeros.

Check whether the first invariant zero is a transmission zero of `H`.

If `z(1)` is a transmission zero of `H`, then `H` drops rank at $s = z(1)$.

```
H1 = evalfr(H, z(1));
svd(H1)
```

```
ans = 2×1
   1.5000
```



```
0.0000
```

$H1$ is the transfer function, H , evaluated at $s = z(1)$. $H1$ has a zero singular value, indicating that H drops rank at that value of s . Therefore, $z(1)$ is a transmission zero of H .

A similar analysis shows that $z(2)$ is also a transmission zero.

Identify Unobservable and Uncontrollable Modes of MIMO Model

Obtain a MIMO model.

```
load ltiexamples gasf
size(gasf)
```

State-space model with 4 outputs, 6 inputs, and 25 states.

`gasf` is a MIMO model that might contain uncontrollable or unobservable states.

To identify the unobservable and uncontrollable modes of `gasf`, you need the state-space matrices A , B , C , and D of the model. `tzero` does not scale state-space matrices. Therefore, use `prescale` with `ssdata` to scale the state-space matrices of `gasf`.

```
[A,B,C,D] = ssdata(prescale(gasf));
```

Identify the uncontrollable states of `gasf`.

```
uncon = tzero(A,B,[],[])
```

```
uncon = 6×1
```

```
-0.0568
-0.0568
-0.0568
-0.0568
-0.0568
-0.0568
```

When you provide A and B matrices to `tzero`, but no C and D matrices, the command returns the eigenvalues of the uncontrollable modes of `gasf`. The output shows that there are six degenerate uncontrollable modes.

Identify the unobservable states of `gasf`.

```
unobs = tzero(A,[],C,[])
```

```
unobs =
```

```
0×1 empty double column vector
```

When you provide A and C matrices, but no B and D matrices, the command returns the eigenvalues of the unobservable modes. The empty result shows that `gasf` contains no unobservable states.

More About

Invariant zeros

For a MIMO state-space model

$$E \frac{dx}{dt} = Ax + Bu$$

$$y = Cx + Du,$$

the invariant zeros are the complex values of s for which the rank of the system matrix

$$\begin{bmatrix} A - sE & B \\ C & D \end{bmatrix}$$

drops from its normal value. (For explicit state-space models, $E = I$).

Transmission zeros

For a MIMO state-space model

$$E \frac{dx}{dt} = Ax + Bu$$

$$y = Cx + Du,$$

the transmission zeros are the complex values of s for which the rank of the equivalent transfer function $H(s) = D + C(sE - A)^{-1}B$ drops from its normal value. (For explicit state-space models, $E = I$.)

Transmission zeros are a subset of the invariant zeros on page 2-1464. For minimal realizations, the transmission zeros and invariant zeros are identical.

Tips

- You can use the syntax `z = tzero(A,B,C,D,E)` to find the uncontrollable or unobservable modes of a state-space model. When C and D are empty or zero, `tzero` returns the uncontrollable modes of $(A - sE, B)$. Similarly, when B and D are empty or zero, `tzero` returns the unobservable modes of $(C, A - sE)$. See “Identify Unobservable and Uncontrollable Modes of MIMO Model” on page 2-1463 for an example.

Algorithms

`tzero` is based on SLICOT routines AB08ND, AB08NZ, AG08BD, and AG08BZ. `tzero` implements the algorithms in [1] and [2].

Alternatives

To calculate the zeros and gain of a single-input, single-output (SISO) system, use `zero`.

Version History

Introduced in R2012a

References

- [1] Emami-Naeini, A. and P. Van Dooren, "Computation of Zeros of Linear Multivariable Systems," *Automatica*, 18 (1982), pp. 415-430.
- [2] Misra, P, P. Van Dooren, and A. Varga, "Computation of Structural Invariants of Generalized State-Space Systems," *Automatica*, 30 (1994), pp. 1921-1936.

See Also

[pole](#) | [pzmap](#) | [zero](#)

unscentedKalmanFilter

Create unscented Kalman filter object for online state estimation

Syntax

```
obj = unscentedKalmanFilter(StateTransitionFcn,MeasurementFcn,InitialState)
obj = unscentedKalmanFilter(StateTransitionFcn,MeasurementFcn,InitialState,
Name,Value)
```

```
obj = unscentedKalmanFilter(StateTransitionFcn,MeasurementFcn)
obj = unscentedKalmanFilter(StateTransitionFcn,MeasurementFcn,Name,Value)
obj = unscentedKalmanFilter(Name,Value)
```

Description

`obj = unscentedKalmanFilter(StateTransitionFcn,MeasurementFcn,InitialState)` creates an unscented Kalman filter object for online state estimation of a discrete-time nonlinear system. `StateTransitionFcn` is a function that calculates the state of the system at time k , given the state vector at time $k-1$. `MeasurementFcn` is a function that calculates the output measurement of the system at time k , given the state at time k . `InitialState` specifies the initial value of the state estimates.

After creating the object, use the `correct` and `predict` commands to update state estimates and state estimation error covariance values using a discrete-time unscented Kalman filter algorithm and real-time data.

`obj = unscentedKalmanFilter(StateTransitionFcn,MeasurementFcn,InitialState,Name,Value)` specifies additional attributes of the unscented Kalman filter object using one or more `Name,Value` pair arguments.

`obj = unscentedKalmanFilter(StateTransitionFcn,MeasurementFcn)` creates an unscented Kalman filter object using the specified state transition and measurement functions. Before using the `predict` and `correct` commands, specify the initial state values using dot notation. For example, for a two-state system with initial state values $[1;0]$, specify `obj.State = [1;0]`.

`obj = unscentedKalmanFilter(StateTransitionFcn,MeasurementFcn,Name,Value)` specifies additional attributes of the unscented Kalman filter object using one or more `Name,Value` pair arguments. Before using the `predict` and `correct` commands, specify the initial state values using `Name,Value` pair arguments or dot notation.

`obj = unscentedKalmanFilter(Name,Value)` creates an unscented Kalman filter object with properties specified using one or more `Name,Value` pair arguments. Before using the `predict` and `correct` commands, specify the state transition function, measurement function, and initial state values using `Name,Value` pair arguments or dot notation.

Object Description

`unscentedKalmanFilter` creates an object for online state estimation of a discrete-time nonlinear system using the discrete-time unscented Kalman filter algorithm.

Consider a plant with states x , input u , output y , process noise w , and measurement noise v . Assume that you can represent the plant as a nonlinear system.

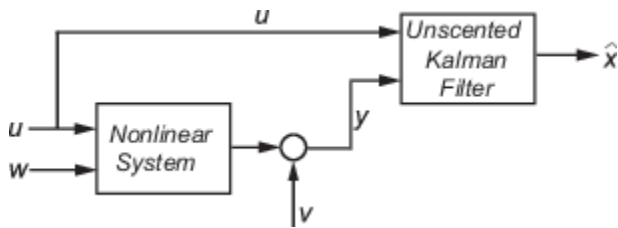

The algorithm computes the state estimates \hat{x} of the nonlinear system using state transition and measurement functions specified by you. The software lets you specify the noise in these functions as additive or nonadditive:

- **Additive Noise Terms** — The state transition and measurements equations have the following form:

$$\begin{aligned}x[k] &= f(x[k-1], u_s[k-1]) + w[k-1] \\y[k] &= h(x[k], u_m[k]) + v[k]\end{aligned}$$

Here f is a nonlinear state transition function that describes the evolution of states x from one time step to the next. The nonlinear measurement function h relates x to the measurements y at time step k . w and v are the zero-mean, uncorrelated process and measurement noises, respectively. These functions can also have additional input arguments that are denoted by u_s and u_m in the equations. For example, the additional arguments could be time step k or the inputs u to the nonlinear system. There can be multiple such arguments.

Note that the noise terms in both equations are additive. That is, $x(k)$ is linearly related to the process noise $w(k-1)$, and $y(k)$ is linearly related to the measurement noise $v(k)$.

- **Nonadditive Noise Terms** — The software also supports more complex state transition and measurement functions where the state $x[k]$ and measurement $y[k]$ are nonlinear functions of the process noise and measurement noise, respectively. When the noise terms are nonadditive, the state transition and measurements equation have the following form:

$$\begin{aligned}x[k] &= f(x[k-1], w[k-1], u_s[k-1]) \\y[k] &= h(x[k], v[k], u_m[k])\end{aligned}$$

When you perform online state estimation, you first create the nonlinear state transition function f and measurement function h . You then construct the `unscentedKalmanFilter` object using these nonlinear functions, and specify whether the noise terms are additive or nonadditive. After you create the object, you use the `predict` command to predict state estimates at the next time step, and `correct` to correct state estimates using the unscented Kalman filter algorithm and real-time data. For information about the algorithm, see “Extended and Unscented Kalman Filter Algorithms for Online State Estimation”.

You can use the following commands with `unscentedKalmanFilter` objects:

Command	Description
<code>correct</code>	Correct the state and state estimation error covariance at time step k using measured data at time step k .
<code>predict</code>	Predict the state and state estimation error covariance at time the next time step.
<code>residual</code>	Return the difference between the actual and predicted measurements.
<code>clone</code>	Create another object with the same object property values. Do not create additional objects using syntax <code>obj2 = obj</code> . Any changes made to the properties of the new object created in this way (<code>obj2</code>) also change the properties of the original object (<code>obj</code>).

For `unscentedKalmanFilter` object properties, see “Properties” on page 2-1472.

Examples

Create Unscented Kalman Filter Object for Online State Estimation

To define an unscented Kalman filter object for estimating the states of your system, you write and save the state transition function and measurement function for the system.

In this example, use the previously written and saved state transition and measurement functions, `vdpStateFcn.m` and `vdpMeasurementFcn.m`. These functions describe a discrete-approximation to van der Pol oscillator with nonlinearity parameter, μ , equal to 1. The oscillator has two states.

Specify an initial guess for the two states. You specify the initial state guess as an M -element row or column vector, where M is the number of states.

```
initialStateGuess = [1;0];
```

Create the unscented Kalman filter object. Use function handles to provide the state transition and measurement functions to the object.

```
obj = unscentedKalmanFilter(@vdpStateFcn,@vdpMeasurementFcn,initialStateGuess);
```

The object has a default structure where the process and measurement noise are additive.

To estimate the states and state estimation error covariance from the constructed object, use the `correct` and `predict` commands and real-time data.

Specify Process and Measurement Noise Covariances in Unscented Kalman Filter Object

Create an unscented Kalman filter object for a van der Pol oscillator with two states and one output. Use the previously written and saved state transition and measurement functions, `vdpStateFcn.m`

and `vdpMeasurementFcn.m`. These functions are written for additive process and measurement noise terms. Specify the initial state values for the two states as `[2;0]`.

Since the system has two states and the process noise is additive, the process noise is a 2-element vector and the process noise covariance is a 2-by-2 matrix. Assume there is no cross-correlation between process noise terms, and both the terms have the same variance 0.01. You can specify the process noise covariance as a scalar. The software uses the scalar value to create a 2-by-2 diagonal matrix with 0.01 on the diagonals.

Specify the process noise covariance during object construction.

```
obj = unscentedKalmanFilter(@vdpStateFcn,@vdpMeasurementFcn,[2;0],...
    'ProcessNoise',0.01);
```

Alternatively, you can specify noise covariances after object construction using dot notation. For example, specify the measurement noise covariance as 0.2.

```
obj.MeasurementNoise = 0.2;
```

Since the system has only one output, the measurement noise is a 1-element vector and the `MeasurementNoise` property denotes the variance of the measurement noise.

Specify Nonadditive Measurement Noise in Unscented Kalman Filter Object

Create an unscented Kalman filter object for a van der Pol oscillator with two states and one output. Assume that the process noise terms in the state transition function are additive. That is, there is a linear relation between the state and process noise. Also assume that the measurement noise terms are nonadditive. That is, there is a nonlinear relation between the measurement and measurement noise.

```
obj = unscentedKalmanFilter('HasAdditiveMeasurementNoise',false);
```

Specify the state transition function and measurement functions. Use the previously written and saved functions, `vdpStateFcn.m` and `vdpMeasurementNonAdditiveNoiseFcn.m`.

The state transition function is written assuming the process noise is additive. The measurement function is written assuming the measurement noise is nonadditive.

```
obj.StateTransitionFcn = @vdpStateFcn;
obj.MeasurementFcn = @vdpMeasurementNonAdditiveNoiseFcn;
```

Specify the initial state values for the two states as `[2;0]`.

```
obj.State = [2;0];
```

You can now use the `correct` and `predict` commands to estimate the state and state estimation error covariance values from the constructed object.

Specify Additional Inputs in State Transition and Measurement Functions

Consider a nonlinear system with input u whose state x and measurement y evolve according to the following state transition and measurement equations:

$$x[k] = \sqrt{x[k-1] + u[k-1]} + w[k-1]$$

$$y[k] = x[k] + 2 * u[k] + v[k]^2$$

The process noise w of the system is additive while the measurement noise v is nonadditive.

Create the state transition function and measurement function for the system. Specify the functions with an additional input u .

```
f = @(x,u)(sqrt(x+u));
h = @(x,v,u)(x+2*u+v^2);
```

f and h are function handles to the anonymous functions that store the state transition and measurement functions, respectively. In the measurement function, because the measurement noise is nonadditive, v is also specified as an input. Note that v is specified as an input before the additional input u .

Create an unscented Kalman filter object for estimating the state of the nonlinear system using the specified functions. Specify the initial value of the state as 1, and the measurement noise as nonadditive.

```
obj = unscentedKalmanFilter(f,h,1,'HasAdditiveMeasurementNoise',false);
```

Specify the measurement noise covariance.

```
obj.MeasurementNoise = 0.01;
```

You can now estimate the state of the system using the `predict` and `correct` commands. You pass the values of u to `predict` and `correct`, which in turn pass them to the state transition and measurement functions, respectively.

Correct the state estimate with measurement $y[k]=0.8$ and input $u[k]=0.2$ at time step k .

```
correct(obj,0.8,0.2)
```

Predict the state at next time step, given $u[k]=0.2$.

```
predict(obj,0.2)
```

Input Arguments

StateTransitionFcn — State transition function

function handle

State transition function f , specified as a function handle. The function calculates the N_s -element state vector of the system at time step k , given the state vector at time step $k-1$. N_s is the number of states of the nonlinear system.

You write and save the state transition function for your nonlinear system, and use it to construct the object. For example, if `vdpStateFcn.m` is the state transition function, specify `StateTransitionFcn` as `@vdpStateFcn`. You can also specify `StateTransitionFcn` as a function handle to an anonymous function.

The inputs to the function you write depend on whether you specify the process noise as additive or nonadditive in the `HasAdditiveProcessNoise` property of the object:

- `HasAdditiveProcessNoise` is true — The process noise w is additive, and the state transition function specifies how the states evolve as a function of state values at the previous time step:

$$x(k) = f(x(k-1), U_{s1}, \dots, U_{sn})$$

Where $x(k)$ is the estimated state at time k , and U_{s1}, \dots, U_{sn} are any additional input arguments required by your state transition function, such as system inputs or the sample time. During estimation, you pass these additional arguments to the `predict` command, which in turn passes them to the state transition function.

- `HasAdditiveProcessNoise` is false — The process noise is nonadditive, and the state transition function also specifies how the states evolve as a function of the process noise:

$$x(k) = f(x(k-1), w(k-1), U_{s1}, \dots, U_{sn})$$

To see an example of a state transition function with additive process noise, type `edit vdpStateFcn` at the command line.

MeasurementFcn — Measurement function

function handle

Measurement function h , specified as a function handle. The function calculates the N -element output measurement vector of the nonlinear system at time step k , given the state vector at time step k . N is the number of measurements of the system. You write and save the measurement function, and use it to construct the object. For example, if `vdpMeasurementFcn.m` is the measurement function, specify `MeasurementFcn` as `@vdpMeasurementFcn`. You can also specify `MeasurementFcn` as a function handle to an anonymous function.

The inputs to the function depend on whether you specify the measurement noise as additive or nonadditive in the `HasAdditiveMeasurementNoise` property of the object:

- `HasAdditiveMeasurementNoise` is true — The measurement noise v is additive, and the measurement function specifies how the measurements evolve as a function of state values:

$$y(k) = h(x(k), U_{m1}, \dots, U_{mn})$$

Where $y(k)$ and $x(k)$ are the estimated output and estimated state at time k , and U_{m1}, \dots, U_{mn} are any optional input arguments required by your measurement function. For example, if you are using multiple sensors for tracking an object, an additional input could be the sensor position. During estimation, you pass these additional arguments to the `correct` command, which in turn passes them to the measurement function.

- `HasAdditiveMeasurementNoise` is false — The measurement noise is nonadditive, and the measurement function also specifies how the output measurement evolves as a function of the measurement noise:

$$y(k) = h(x(k), v(k), U_{m1}, \dots, U_{mn})$$

When you have the `HasMeasurementWrapping` property enabled, then the output for the measurement function must also include the wrapping bounds, specified as an N -by-2 matrix where, the first column provides the minimum measurement bound and the second column provides the maximum measurement bound. N is the number of measurements of the system.

To see an example of a measurement function with additive process noise, type `edit vdpMeasurementFcn` at the command line. To see an example of a measurement function with nonadditive process noise, type `edit vdpMeasurementNonAdditiveNoiseFcn`.

InitialState — Initial state estimates

vector

Initial state estimates, specified as an N_s -element vector, where N_s is the number of states in the system. Specify the initial state values based on your knowledge of the system.

The specified value is stored in the `State` property of the object. If you specify `InitialState` as a column vector then `State` is also a column vector, and `predict` and `correct` commands return state estimates as a column vector. Otherwise, a row vector is returned.

If you want a filter with single-precision floating-point variables, specify `InitialState` as a single-precision vector variable. For example, for a two-state system with state transition and measurement functions `vdpStateFcn.m` and `vdpMeasurementFcn.m`, create the unscented Kalman filter object with initial states `[1;2]` as follows:

```
obj = unscentedKalmanFilter(@vdpStateFcn,@vdpMeasurementFcn,single([1;2]))
```

Data Types: `double` | `single`

Name-Value Pair Arguments

Specify optional pairs of arguments as `Name1=Value1, ..., NameN=ValueN`, where `Name` is the argument name and `Value` is the corresponding value. Name-value arguments must appear after other arguments, but the order of the pairs does not matter.

Before R2021a, use commas to separate each name and value, and enclose Name in quotes.

Use `Name, Value` arguments to specify properties on page 2-1472 of `unscentedKalmanFilter` object during object creation. For example, to create an unscented Kalman filter object and specify the process noise covariance as 0.01:

```
obj = unscentedKalmanFilter(StateTransitionFcn,MeasurementFcn,InitialState,'ProcessNoise',0.01);
```

Properties

`unscentedKalmanFilter` object properties are of three types:

- Tunable properties that you can specify multiple times, either during object construction using `Name, Value` arguments, or any time afterwards during state estimation. After object creation, use dot notation to modify the tunable properties.

```
obj = unscentedKalmanFilter(StateTransitionFcn,MeasurementFcn,InitialState);
obj.ProcessNoise = 0.01;
```

The tunable properties are `State`, `StateCovariance`, `ProcessNoise`, `MeasurementNoise`, `Alpha`, `Beta`, and `Kappa`.

- Nontunable properties that you can specify once, either during object construction or afterward using dot notation. Specify these properties before state estimation using `correct` and `predict`. The `StateTransitionFcn` and `MeasurementFcn` properties belong to this category.
- Nontunable properties that you must specify during object construction. The `HasAdditiveProcessNoise` and `HasAdditiveMeasurementNoise` properties belong to this category.

Alpha — Spread of sigma points

$1e-3$ (default) | scalar value between 0 and 1

Spread of sigma points around mean state value, specified as a scalar value between 0 and 1 ($0 < \text{Alpha} \leq 1$).

The unscented Kalman filter algorithm treats the state of the system as a random variable with mean value `State` and variance `StateCovariance`. To compute the state and its statistical properties at the next time step, the algorithm first generates a set of state values distributed around the mean `State` value by using the unscented transformation. These generated state values are called sigma points. The algorithm uses each of the sigma points as an input to the state transition and measurement functions to get a new set of transformed state points and measurements. The transformed points are used to compute the state and state estimation error covariance value at the next time step.

The spread of the sigma points around the mean state value is controlled by two parameters `Alpha` and `Kappa`. A third parameter, `Beta`, impacts the weights of the transformed points during state and measurement covariance calculations:

- `Alpha` — Determines the spread of the sigma points around the mean state value. It is usually a small positive value. The spread of sigma points is proportional to `Alpha`. Smaller values correspond to sigma points closer to the mean state.
- `Kappa` — A second scaling parameter that is usually set to 0. Smaller values correspond to sigma points closer to the mean state. The spread is proportional to the square-root of `Kappa`.
- `Beta` — Incorporates prior knowledge of the distribution of the state. For Gaussian distributions, `Beta = 2` is optimal.

If you know the distribution of state and state covariance, you can adjust these parameters to capture the transformation of higher-order moments of the distribution. The algorithm can track only a single peak in the probability distribution of the state. If there are multiple peaks in the state distribution of your system, you can adjust these parameters so that the sigma points stay around a single peak. For example, choose a small `Alpha` to generate sigma points close to the mean state value.

For more information, see “Unscented Kalman Filter Algorithm”.

`Alpha` is a tunable property. You can change it using dot notation.

Beta — Characterization of state distribution

2 (default) | scalar value greater than or equal to 0

Characterization of the state distribution that is used to adjust weights of transformed sigma points, specified as a scalar value greater than or equal to 0. For Gaussian distributions, `Beta = 2` is an optimal choice.

For more information, see the `Alpha` property description.

`Beta` is a tunable property. You can change it using dot notation.

HasAdditiveMeasurementNoise — Measurement noise characteristics

true (default) | false

Measurement noise characteristics, specified as one of the following values:

- `true` — Measurement noise v is additive. The measurement function h that is specified in `MeasurementFcn` has the following form:

$$y(k) = h(x(k), U_{m1}, \dots, U_{mn})$$

Where $y(k)$ and $x(k)$ are the estimated output and estimated state at time k , and $Um1, \dots, Umn$ are any optional input arguments required by your measurement function.

- `false` — Measurement noise is nonadditive. The measurement function specifies how the output measurement evolves as a function of the state *and* measurement noise:

$$y(k) = h(x(k), v(k), Um1, \dots, Umn)$$

`HasAdditiveMeasurementNoise` is a nontunable property, and you can specify it only during object construction. You cannot change it using dot notation.

HasAdditiveProcessNoise — Process noise characteristics

`true (default) | false`

Process noise characteristics, specified as one of the following values:

- `true` — Process noise w is additive. The state transition function f specified in `StateTransitionFcn` has the following form:

$$x(k) = f(x(k-1), Us1, \dots, Usn)$$

Where $x(k)$ is the estimated state at time k , and $Us1, \dots, Usn$ are any additional input arguments required by your state transition function.

- `false` — Process noise is nonadditive. The state transition function specifies how the states evolve as a function of the state *and* process noise at the previous time step:

$$x(k) = f(x(k-1), w(k-1), Us1, \dots, Usn)$$

`HasAdditiveProcessNoise` is a nontunable property, and you can specify it only during object construction. You cannot change it using dot notation.

Kappa — Spread of sigma points

`0 (default) | scalar value between 0 and 3`

Spread of sigma points around mean state value, specified as a scalar value between 0 and 3 ($0 \leq \text{Kappa} \leq 3$). `Kappa` is typically specified as 0. Smaller values correspond to sigma points closer to the mean state. The spread is proportional to the square-root of `Kappa`. For more information, see the `Alpha` property description.

`Kappa` is a tunable property. You can change it using dot notation.

MeasurementFcn — Measurement function

function handle

Measurement function h , specified as a function handle. The function calculates the N -element output measurement vector of the nonlinear system at time step k , given the state vector at time step k . N is the number of measurements of the system. You write and save the measurement function and use it to construct the object. For example, if `vdpMeasurementFcn.m` is the measurement function, specify `MeasurementFcn` as `@vdpMeasurementFcn`. You can also specify `MeasurementFcn` as a function handle to an anonymous function.

The inputs to the function depend on whether you specify the measurement noise as additive or nonadditive in the `HasAdditiveMeasurementNoise` property of the object:

- `HasAdditiveMeasurementNoise` is `true` — The measurement noise v is additive, and the measurement function specifies how the measurements evolve as a function of state values:

$$y(k) = h(x(k), Um1, \dots, Umn)$$

Where $y(k)$ and $x(k)$ are the estimated output and estimated state at time k , and $Um1, \dots, Umn$ are any optional input arguments required by your measurement function. For example, if you are using multiple sensors for tracking an object, an additional input could be the sensor position. During estimation, you pass these additional arguments to the `correct` command which in turn passes them to the measurement function.

- `HasAdditiveMeasurementNoise` is false — The measurement noise is nonadditive, and the measurement function also specifies how the output measurement evolves as a function of the measurement noise:

$$y(k) = h(x(k), v(k), Um1, \dots, Umn)$$

When you have the `HasMeasurementWrapping` property enabled, then the output for the measurement function must also include the wrapping bounds, specified as an N -by-2 matrix where, the first column provides the minimum measurement bound and the second column provides the maximum measurement bound. N is the number of measurements of the system.

To see an example of a measurement function with additive process noise, type `edit vdpMeasurementFcn` at the command line. To see an example of a measurement function with nonadditive process noise, type `edit vdpMeasurementNonAdditiveNoiseFcn`.

`MeasurementFcn` is a nontunable property. You can specify it once before using the `correct` command either during object construction or using dot notation after object construction. You cannot change it after using the `correct` command.

MeasurementNoise — Measurement noise covariance

1 (default) | scalar | matrix

Measurement noise covariance, specified as a scalar or matrix depending on the value of the `HasAdditiveMeasurementNoise` property:

- `HasAdditiveMeasurementNoise` is true — Specify the covariance as a scalar or an N -by- N matrix, where N is the number of measurements of the system. Specify a scalar if there is no cross-correlation between measurement noise terms and all the terms have the same variance. The software uses the scalar value to create an N -by- N diagonal matrix.
- `HasAdditiveMeasurementNoise` is false — Specify the covariance as a V -by- V matrix, where V is the number of measurement noise terms. `MeasurementNoise` must be specified before using `correct`. After you specify `MeasurementNoise` as a matrix for the first time, to then change `MeasurementNoise` you can also specify it as a scalar. Specify as a scalar if there is no cross-correlation between the measurement noise terms and all the terms have the same variance. The software extends the scalar to a V -by- V diagonal matrix with the scalar on the diagonals.

`MeasurementNoise` is a tunable property. You can change it using dot notation.

ProcessNoise — Process noise covariance

1 (default) | scalar | matrix

Process noise covariance, specified as a scalar or matrix depending on the value of the `HasAdditiveProcessNoise` property:

- `HasAdditiveProcessNoise` is true — Specify the covariance as a scalar or an Ns -by- Ns matrix, where Ns is the number of states of the system. Specify a scalar if there is no cross-correlation

between process noise terms, and all the terms have the same variance. The software uses the scalar value to create an N_s -by- N_s diagonal matrix.

- `HasAdditiveProcessNoise` is false — Specify the covariance as a W -by- W matrix, where W is the number of process noise terms. `ProcessNoise` must be specified before using `predict`. After you specify `ProcessNoise` as a matrix for the first time, to then change `ProcessNoise` you can also specify it as a scalar. Specify as a scalar if there is no cross-correlation between the process noise terms and all the terms have the same variance. The software extends the scalar to a W -by- W diagonal matrix.

`ProcessNoise` is a tunable property. You can change it using dot notation.

State — State of nonlinear system

`[]` (default) | vector

State of the nonlinear system, specified as a vector of size N_s , where N_s is the number of states of the system.

When you use the `predict` command, `State` is updated with the predicted value at time step k using the state value at time step $k-1$. When you use the `correct` command, `State` is updated with the estimated value at time step k using measured data at time step k .

The initial value of `State` is the value you specify in the `InitialState` input argument during object creation. If you specify `InitialState` as a column vector, then `State` is also a column vector, and the `predict` and `correct` commands return state estimates as a column vector. Otherwise, a row vector is returned. If you want a filter with single-precision floating-point variables, you must specify `State` as a single-precision variable during object construction using the `InitialState` input argument.

`State` is a tunable property. You can change it using dot notation.

StateCovariance — State estimation error covariance

1 (default) | scalar | matrix

State estimation error covariance, specified as a scalar or an N_s -by- N_s matrix, where N_s is the number of states of the system. If you specify a scalar, the software uses the scalar value to create an N_s -by- N_s diagonal matrix.

Specify a high value for the covariance when you do not have confidence in the initial state values that you specify in the `InitialState` input argument.

When you use the `predict` command, `StateCovariance` is updated with the predicted value at time step k using the state value at time step $k-1$. When you use the `correct` command, `StateCovariance` is updated with the estimated value at time step k using measured data at time step k .

`StateCovariance` is a tunable property. You can change it using dot notation after using the `correct` or `predict` commands.

StateTransitionFcn — State transition function

function handle

State transition function f , specified as a function handle. The function calculates the N_s -element state vector of the system at time step k , given the state vector at time step $k-1$. N_s is the number of states of the nonlinear system.

You write and save the state transition function for your nonlinear system and use it to construct the object. For example, if `vdpStateFcn.m` is the state transition function, specify `StateTransitionFcn` as `@vdpStateFcn`. You can also specify `StateTransitionFcn` as a function handle to an anonymous function.

The inputs to the function you write depend on whether you specify the process noise as additive or nonadditive in the `HasAdditiveProcessNoise` property of the object:

- `HasAdditiveProcessNoise` is true — The process noise w is additive, and the state transition function specifies how the states evolve as a function of state values at previous time step:

$$x(k) = f(x(k-1), U_{s1}, \dots, U_{sn})$$

Where $x(k)$ is the estimated state at time k , and U_{s1}, \dots, U_{sn} are any additional input arguments required by your state transition function, such as system inputs or the sample time. During estimation, you pass these additional arguments to the `predict` command, which in turn passes them to the state transition function.

- `HasAdditiveProcessNoise` is false — The process noise is nonadditive, and the state transition function also specifies how the states evolve as a function of the process noise:

$$x(k) = f(x(k-1), w(k-1), U_{s1}, \dots, U_{sn})$$

To see an example of a state transition function with additive process noise, type `edit vdpStateFcn` at the command line.

`StateTransitionFcn` is a nontunable property. You can specify it once before using the `predict` command either during object construction or using dot notation after object construction. You cannot change it after using the `predict` command.

HasMeasurementWrapping — Enable measurement wrapping

0 (default) | 1

Enable measurement wrapping, specified as either 0 or 1. You can enable measurement wrapping to estimate states when you have circular measurements that are independent of your model states. If you select this parameter, then the measurement function you specify must include the following two outputs:

- 1 The measurement, specified as a N -element output measurement vector of the nonlinear system at time step k , given the state vector at time step k . N is the number of measurements of the system.
- 2 The measurement wrapping bounds, specified as an N -by-2 matrix where, the first column provides the minimum measurement bound and the second column provides the maximum measurement bound.

Enabling the `HasMeasurementWrapping` property wraps the measurement residuals in a defined bound, which helps to prevent the filter from divergence due to incorrect measurement residual values. For an example, see “State Estimation with Wrapped Measurements Using Extended Kalman Filter”.

`HasMeasurementWrapping` is a nontunable property. You can specify it once during the object construction. You cannot change it after creating the state estimation object.

Output Arguments

obj — unscented Kalman filter object for online state estimation

`unscentedKalmanFilter` object

Unscented Kalman filter object for online state estimation, returned as an `unscentedKalmanFilter` object. This object is created using the specified properties on page 2-1472. Use the `correct` and `predict` commands to estimate the state and state estimation error covariance using the unscented Kalman filter algorithm.

When you use `predict`, `obj.State` and `obj.StateCovariance` are updated with the predicted value at time step k using the state value at time step $k-1$. When you use `correct`, `obj.State` and `obj.StateCovariance` are updated with the estimated values at time step k using measured data at time step k .

Version History

Introduced in R2016b

Numerical Changes

Behavior changed in R2020b

Starting in R2020b, numerical improvements in the `unscentedKalmanFilter` algorithm might produce results that are different from the results you obtained in previous versions.

Extended Capabilities

C/C++ Code Generation

Generate C and C++ code using MATLAB® Coder™.

Usage notes and limitations:

For more information, see “Generate Code for Online State Estimation in MATLAB”.

Generated code uses an algorithm that is different from the algorithm that the `unscentedKalmanFilter` function uses. You might see some numerical differences in the results obtained using the two methods.

Supports MATLAB Function block: No

See Also

Functions

`predict` | `correct` | `clone` | `extendedKalmanFilter` | `kalman` | `kalmd` | `residual`

Blocks

Kalman Filter | Extended Kalman Filter | Unscented Kalman Filter

Topics

“Nonlinear State Estimation Using Unscented Kalman Filter and Particle Filter”

“Generate Code for Online State Estimation in MATLAB”

“Extended and Unscented Kalman Filter Algorithms for Online State Estimation”

“Validate Online State Estimation at the Command Line”

“Troubleshoot Online State Estimation”

External Websites

Understanding Kalman Filters: Nonlinear State Estimators — MATLAB Video Series

Tune PID Controller

Tune PID Controller for LTI plant in the Live Editor

Description

The **Tune PID Controller** Live Editor task lets you interactively tune a PID controller for a plant. The task automatically generates MATLAB code for your live script. For more information about Live Editor tasks generally, see “Add Interactive Tasks to a Live Script”.

Tune PID Controller automatically tunes the gains of a PID controller for a SISO plant to achieve a balance between performance and robustness. You can specify the controller type, such as PI, PD, or PID with or without a derivative filter. By default, **Tune PID Controller** assumes the following standard unit-feedback control configuration.

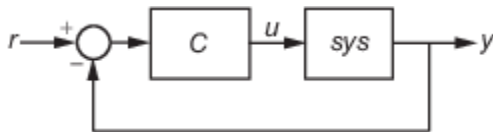

You can also use **Tune PID Controller** to design a 2-DOF PID controller for the feedback configuration of this illustration:

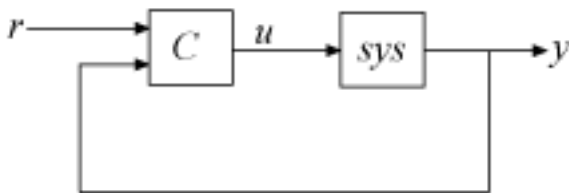

Tune PID Controller generates analysis plots that let you examine controller performance in the time and frequency domains. You can interactively refine the performance of the controller to adjust response time, loop bandwidth, or phase margin, or to favor setpoint tracking or disturbance rejection.

To get started with the **Tune PID Controller** task, select the plant model and specify the type of controller you want to design. Experiment with the sliders and observe their effect on the closed-loop system response. For an example, see “PID Controller Design in the Live Editor”.

Related Functionality

- **Tune PID Controller** generates code using `piddtune` and `piddtuneOptions`.
- To perform interactive PID tuning in a standalone app, use **PID Tuner**.

Tune PID Controller
 [C] pidInfo = PIDF controller in Parallel form tuned for model G with response time of 1.67572 s

▼ Select plant
 Plant: G

▼ Specify controller settings
 Form: Parallel Degrees of Freedom: 1DOF Controller Type: PIDF

▼ Specify system performance goals
 Domain: Time
 Response Time (s): 0.2 to 2 (1.67572)
 Transient Behavior: 0 to 0.9 (0.621113)

► Specify optional parameters

▼ Display results
 Output Plot: Step Plot: Reference tracking System response characteristics:
 Baseline controller: Select from workspace CO

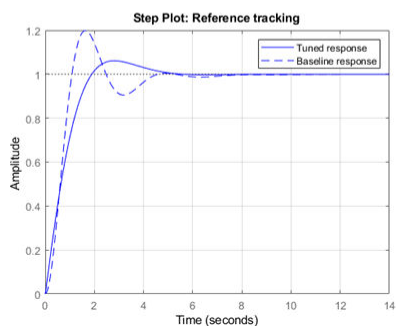

Description (collapsed portion)

Related Functionality

- **Tune PID Controller** generates code using `pidtune` and `pidtuneOptions`.
- To perform interactive PID tuning in a standalone app, use **PID Tuner**.

Open the Task

To add the **Tune PID Controller** task to a live script in the MATLAB Editor:

- On the **Live Editor** tab, select **Task > Tune PID Controller**.
- In a code block in your script, type a relevant keyword, such as `tune` or `PID`. Select **Tune PID Controller** from the suggested command completions.

Parameters

Plant and Controller Settings

Plant — Current plant

LTI model

Choose a plant for which to design a controller. The list contains continuous-time or discrete-time SISO LTI models present in the MATLAB workspace, such as:

- State-space (`ss`), transfer function (`tf`), and zero-pole-gain (`zpk`) models.
- For frequency-response data (`frd`) models. For such plants, only frequency-domain design goals and response plots are available.
- Generalized state-space (`genss`) or uncertain state-space (`uss`) models. For such models, **Tune PID Controllers** uses the current, nominal value of the tunable and uncertain components.
- Identified models, such as `idss` and `idtf` models.

Form — Controller form

'Parallel' | 'Standard'

Specify the controller form. The two forms differ in the parameters used to express the proportional, integral, and derivative actions and the filter on the derivative term. For information about parallel and standard forms, see:

- “Proportional-Integral-Derivative (PID) Controllers”
- “Discrete-Time Proportional-Integral-Derivative (PID) Controllers”
- “Two-Degree-of-Freedom PID Controllers”

Degrees of Freedom — Specify 1-DOF or 2-DOF controller

1DOF (default) | 2DOF

By default, **Tune PID Controller** designs a one-degree-of-freedom (1-DOF) controller. Such a controller has up to four coefficients (see “Proportional-Integral-Derivative (PID) Controllers”).

You can instead design a two-degree-of-freedom (2-DOF) PID controller. Such controllers include setpoint weighting on the proportional and derivative terms. A 2-DOF PID controller is capable of fast disturbance rejection without significant increase of overshoot in setpoint tracking. You can also use 2-DOF PID controllers to mitigate the influence of changes in the reference signal on the control signal. For more information, see “Two-Degree-of-Freedom PID Controllers”.

Controller Type — Specify the terms the controller has

'PI' (default) | 'PIDF' | 'PID2' | ...

The controller type specifies which terms are present in the PID controller. For instance, a PI controller has a proportional and an integral term. A PDF controller has a proportional term and a filtered derivative term. For details on available controller types, see “PID Controller Types for Tuning”.

System Performance Goals

Domain — Domain for specifying performance targets

'Time' (default) | 'Frequency'

Choose the domain in which the task displays the target performance parameters.

- **Time** — Use the sliders to set performance goals in terms of response time and transient behavior. Time-domain tuning is not available for frequency-response data plants such as `frd` plants.
- **Frequency** — Use the sliders to set performance goals in terms of loop bandwidth and phase margin.



The choice of domain does not affect the underlying controller design or the results. You can use whichever is more convenient for you or more appropriate for your application. For instance, if your design goals include a target rise time, you might find it convenient to work in the time domain. If you

have a target loop bandwidth, you might prefer working in the frequency domain. In both domains, there is a trade-off between reference tracking and disturbance rejection performance.

Response Time, Transient Behavior — Time-domain performance goals

sliders

When you set **Domain** to Time, use these sliders to adjust the responsiveness and robustness of the controller.



- Use the **Response Time** slider to make the closed-loop response of the control system faster or slower. To change the limits of the slider, drag the slider to the left or right end. To decrease or increase the response time by a factor of 10, click  or .
- Use the **Transient Behavior** slider to make the controller more aggressive at disturbance rejection (smaller values) or more robust against plant uncertainty (larger values).

Time-domain tuning is not available for frequency-response data plants such as `frd` plants.

Bandwidth, Phase Margin — Frequency-domain performance goals

sliders

When you set **Domain** to Frequency, use these sliders to adjust the bandwidth and phase margin of the control system.

- Use the **Bandwidth** slider to make the closed-loop response of the control system faster or slower (the response time is $2/w_c$, where w_c is the bandwidth). To change the limits of the slider, drag the slider to the left or right end. To decrease or increase the bandwidth by a factor of 10, click  or .

For discrete-time controllers, **Tune PID Controller** limits the maximum bandwidth to π/T_s , where T_s is the sample time of the selected plant.

- Use the **Phase Margin** slider to make the controller more aggressive at disturbance rejection (smaller values) or more robust against plant uncertainty (larger values).

Optional Parameters

Design focus — Closed-loop performance objective to favor

Balanced (default) | Reference tracking | Input disturbance rejection

For a given target phase margin, **Tune PID Controller** chooses a controller design that balances the two measures of performance, reference tracking and disturbance rejection. When you change the **Design focus** option, the tuning algorithm attempts to adjust the PID gains to favor either reference tracking or disturbance rejection while achieving the same target phase margin.

The **Design focus** options follow:

- **Balanced** — For a given robustness, tune the controller to balance reference tracking and disturbance rejection.
- **Reference tracking** — Tune the controller to favor reference tracking, if possible.
- **Input disturbance rejection** — Tune the controller to favor disturbance rejection, if possible.

The more tunable parameters there are in the system, the more likely it is that the PID algorithm can achieve the desired design focus without sacrificing robustness. For example, setting the design focus is more likely to be effective for PID controllers than for P or PI controllers.

In all cases, how much you can fine-tune the performance of the system depends strongly on the properties of your plant. For some plants, changing the **Design Focus** option might have little or no effect.

Integral formula, Filter formula — Formula for discrete integral and derivative terms

Forward Euler (default) | Backward Euler | Trapezoidal

For discrete-time PID controllers, there are different ways to implement the integrator and filter terms. For instance, for a parallel-form discrete-time PID controller, the controller transfer function is

$$C = K_p + K_i IF(z) + \frac{K_d}{T_f + DF(z)}.$$

$IF(z)$ and $DF(z)$ are the discrete integrator formulas for the integrator and derivative filter. (To see how $IF(z)$ and $DF(z)$ affect other controller forms, including standard form and 2-DOF controllers, see “Discrete-Time Proportional-Integral-Derivative (PID) Controllers”.)

Use **Integral formula** and **Filter formula** to select the values of $IF(z)$ and $DF(z)$, respectively.

- Forward Euler — $IF(z)$ or $DF(z) = \frac{T_s}{z-1}$.

This formula is best for small sample times, where the Nyquist limit is large compared to the bandwidth of the controller. For larger sample times, the Forward Euler formula can result in instability, even when you discretize a system that is stable in continuous time.

- Backward Euler — $IF(z)$ or $DF(z) = \frac{T_s z}{z-1}$.

An advantage of the Backward Euler formula is that discretizing a stable continuous-time system using this formula always yields a stable discrete-time result.

- Trapezoidal — $IF(z)$ or $DF(z) = \frac{T_s z + 1}{2(z-1)}$.

An advantage of the Trapezoidal formula is that discretizing a stable continuous-time system using this method always yields a stable discrete-time result. Of all available discrete integrator formulas, Trapezoidal yields the closest match between the frequency-domain properties of the discretized system and the corresponding continuous-time system.

Display

Output Plot — System response plot to generate

Step Plot: Reference tracking (default) | Step Plot: Input disturbance rejection |
Bode Plot: Open-loop | ...

Specify a response plot for observing the effect of the PID controller on system performance. You can specify a time-domain step response plot or a frequency-domain Bode plot for different system responses. The code that **Tune PID Controller** generates in your live script includes code for generating the plot you select.

Available System Responses

For 1-DOF PID controller types such as PI, PIDF, and PDF, the software computes system responses based upon the following single-loop control architecture, where G is your specified plant and C is the PID controller:

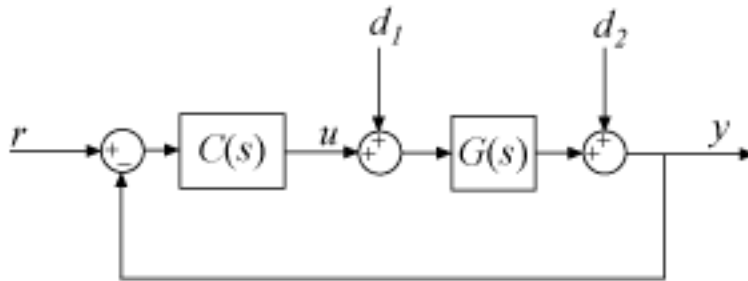

For 2-DOF PID controller types such as PI2, PIDF2, and I-PD, the software computes responses based upon the following architecture:

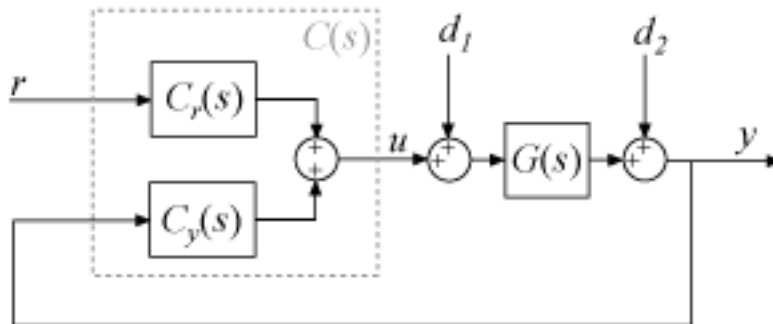

The system responses are based on the decomposition of the 2-DOF PID controller, C , into a setpoint component C_r and a feedback component C_y , as described in “Two-Degree-of-Freedom PID Controllers”.

The following table summarizes the available responses for analysis plots. (For frequency-response-data plants such as frd models, time-domain response plots are not available.)

Response	Plotted System (1-DOF)	Plotted System (2-DOF)	Description
Plant	G	G	Plant response. Use to examine plant dynamics.

Response	Plotted System (1-DOF)	Plotted System (2-DOF)	Description
Open-loop	GC	$-GC_y$	Response of the open-loop controller-plant system. Use for frequency-domain design. Use when your design specifications include robustness criteria such as open-loop gain margin and phase margin.
Reference tracking	$\frac{GC}{1+GC}$ (from r to y)	$\frac{GC_r}{1-GC_y}$ (from r to y)	Closed-loop system response to a step change in setpoint. Use when your design specifications include setpoint tracking.
Controller effort	$\frac{C}{1+GC}$ (from r to u)	$\frac{C_r}{1-GC_y}$ (from r to u)	Closed-loop controller output response to a step change in setpoint. Use when your design is limited by practical constraints, such as controller saturation.
Input disturbance rejection	$\frac{G}{1+GC}$ (from d_1 to y)	$\frac{G}{1-GC_y}$ (from d_1 to y)	Closed-loop system response to load disturbance (a step disturbance at the plant input). Use when your design specifications include input disturbance rejection.
Output disturbance rejection	$\frac{1}{1+GC}$ (from d_2 to y)	$\frac{1}{1-GC_y}$ (from d_2 to y)	Closed-loop system response to a step disturbance at plant output. Use when you want to analyze sensitivity to modeling errors.

System response characteristics – Display numeric characteristics of closed-loop response

off (default) | on

Select this option to generate a display of numeric characteristics of the closed-loop or open-loop response.

- When **Output Plot** is a step plot, the display includes characteristics such as rise time, settling time, and percent overshoot. These values are always those of the closed-loop step response from the control system input r to output y , regardless of which specific step response you choose for the plot. **Tune PID Controller** uses `stepinfo` to compute the step-response characteristics. For details about how to interpret these values, see the `stepinfo` reference page.

- When **Output Plot** is a Bode plot, the display includes characteristics such as gain margin and phase margin. These values are always those of the open-loop system response GC , regardless of which specific Bode plot you choose. **Tune PID Controller** uses `allmargin` to compute the frequency-response characteristics. For details about how to interpret these values, see the `allmargin` reference page.

Baseline controller — Controller for performance comparison

None (default) | `Select from workspace`

Use this option when you want to compare the performance of the tuned controller to another PID controller in the MATLAB workspace. To do so, choose `Select from workspace`. Another menu appears containing PID model objects that are currently in the workspace. The list includes PID model objects of all types (`pid`, `pidstd`, `pid2`, or `pidstd2`) that are of the same time domain as the currently specified plant. For instance, if the plant is a discrete-time state-space model, then any discrete-time PID model object in the workspace is available as a baseline controller.

When you specify a baseline controller, the response plot updates to include a dotted-line plot of the system response with the baseline controller.

▼ **Display results**

Output Plot System response characteristics

Baseline controller

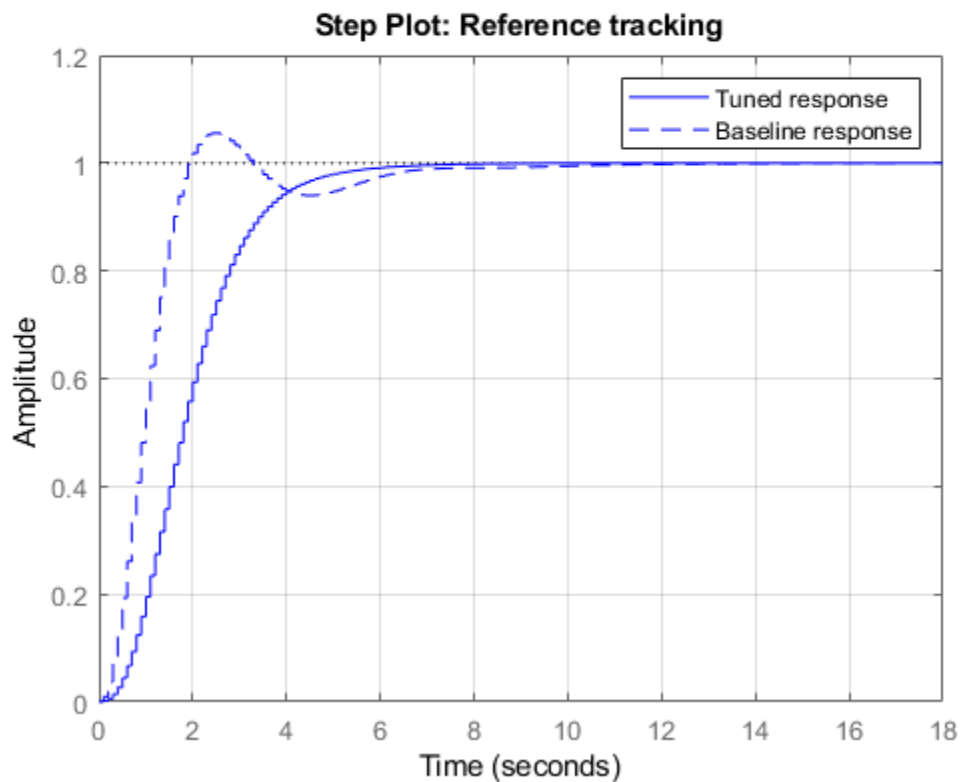

Store Controller for Comparison

You can store a design to use as a baseline while you experiment further with controller types, performance goals, and other settings. To do so, when you find the design that you want to use as a baseline:

- 1 Note the name of the controller workspace variable in the task summary line (see “Tips” on page 2-1489). For instance, if the name is `C`, then the current controller is in the MATLAB workspace as `C`.
- 2 Change the name of the controller variable in the task summary line. For instance, change it to `Cnew`.
- 3 Select **Baseline Controller** and specify the stored controller `C` as the baseline.

When you experiment further with the controller design, the task stores changes to the controller in the workspace as `Cnew`. The plot shows you the baseline response using `C` and the tuned response using `Cnew`.

Tips

- After you select a plant, the task creates the controller and stores it in the MATLAB workspace. The stored controller is a `pid`, `pidstd`, `pid2`, or `pidstd2` model object, as specified by your selections for **Form** and **Degrees of Freedom**.

The default variable name for the stored controller is `C`. You can change the variable name by typing a new name into the task summary line.

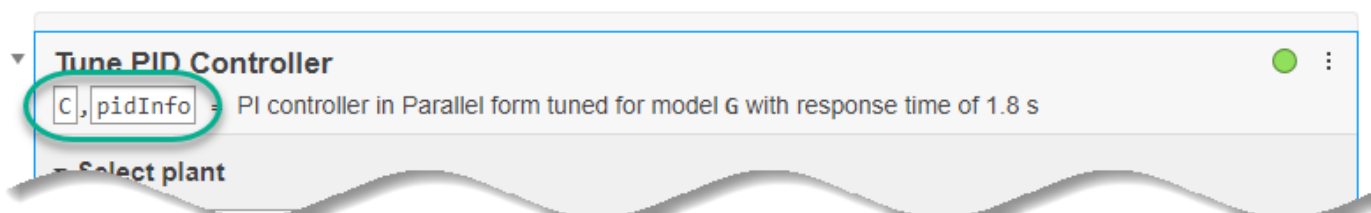

- The task also provides information about the performance and robustness of the closed-loop system in a structure called `pidInfo` by default. For information about this structure, see the `info` output argument on the `pidtune` reference page.

Algorithms

Tune PID Controller uses the algorithm discussed in “PID Tuning Algorithm”.

Version History

Introduced in R2019b

See Also

Apps

PID Tuner

Functions

`pidtune` | `pidtuneOptions`

Objects

`pid` | `pidstd` | `pid2` | `pidstd2`

Topics

“PID Controller Design in the Live Editor”

“Choosing a PID Controller Design Tool”

updateSystem

Update dynamic system data in a response plot

Syntax

```
updateSystem(h,sys)  
updateSystem(h,sys,N)
```

Description

`updateSystem(h,sys)` replaces the dynamic system used to compute a response plot with the dynamic system model or model array `sys`, and updates the plot. If the plot with handle `h` contains more than one system response, this syntax replaces the first response in the plot. `updateSystem` is useful, for example, to cause a plot in a GUI to update in response to interactive input. See “Build GUI With Interactive Response-Plot Updates”.

`updateSystem(h,sys,N)` replaces the data used to compute the `N`th response in the plot.

Examples

Update System Data in Response Plot

Replace step response data in an existing plot with data computed from a different dynamic system model.

Suppose you have a plant model and pure integrator controller that you designed for that plant. Plot the step responses of the plant and the closed-loop system.

```
w = 2;  
zeta = 0.5;  
G = tf(w^2,[1,2*zeta*w,w^2]);
```

```
C1 = pid(0,0.621);  
CL1 = feedback(G*C1,1);
```

```
h = stepplot(G,CL1);
```

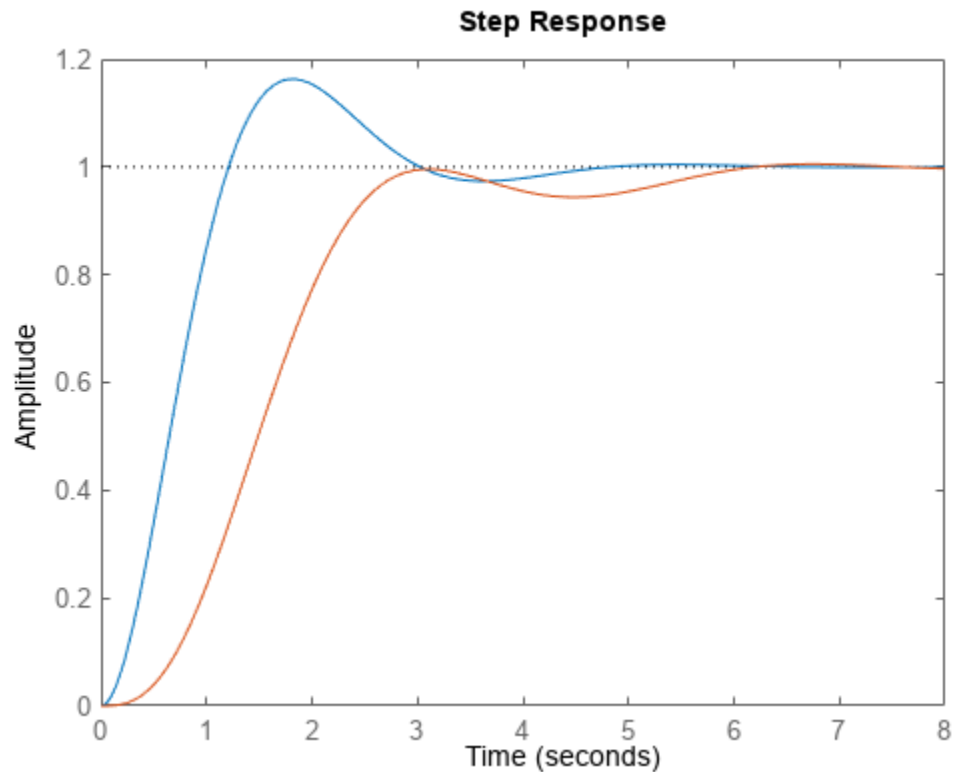

`h` is the plot handle that identifies the plot created by `stepplot`. In this figure, `G` is used to compute the first response, and `CL1` is used to compute the second response. This ordering corresponds to the order of inputs to `stepplot`.

Suppose you also have a PID controller design that you want to analyze. Create a model of the closed-loop system using this alternate controller.

```
C2 = pid(2,2.6,0.4,0.002);
CL2 = feedback(G*C2,1);
```

Update the step plot to display the second closed-loop system instead of the first. The closed-loop system is the second response in the plot, so specify the index value 2.

```
updateSystem(h,CL2,2);
```

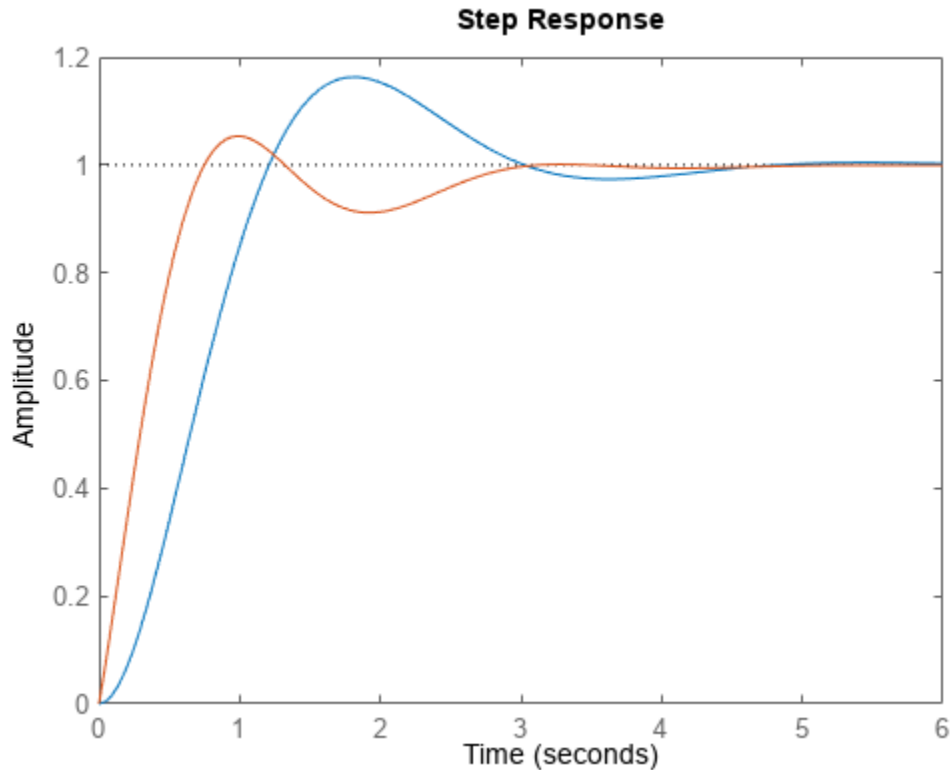

The `updateSystem` command replaces the system used to compute the second response displayed in the plot. Instead of displaying response data derived from CL1, the plot now shows data derived from CL2.

When you build a GUI that displays a response plot, use `updateSystem` in GUI control callbacks to cause those GUI controls to update the response plot. For an example showing how to implement such a GUI control, see “Build GUI With Interactive Response-Plot Updates”.

Input Arguments

h — Plot to update

plot handle

Plot to update with new system data, specified as a plot handle. Typically, you obtain the plot handle as an output argument of a response plotting command such as `stepplot` or `bodeplot`. For example, the command `h = bodeplot(G)` returns a handle to a plot containing the Bode response of a dynamic system, `G`.

sys — System for new response data

dynamic system model | model array

System from which to compute new response data for the response plot, specified as a dynamic system model or model array.

`sys` must match the plotted system that it replaces in both I/O dimensions and array dimensions. For example, suppose `h` refers to a plot that displays the step responses of a 5-element vector of 2-input, 2-output systems. In this case, `sys` must also be a 5-element vector of 2-input, 2-output systems. The number of states in the elements of `sys` need not match the number of states in the plotted systems.

N — Index of system to replace

1 (default) | positive integer

Index of system to replace in the plot, specified as a positive integer. For example, suppose you create a plot using the following command.

```
h = impulseplot(G1,G2,G3,G4);
```

To replace the impulse data of `G3` with data from a new system, `sys`, use the following command.

```
updateSystem(h,sys,3);
```

Version History

Introduced in R2013b

See Also

Topics

“Build GUI With Interactive Response-Plot Updates”

upsample

Upsample discrete-time models

Syntax

```
sysl = upsample(sys,L)
```

Description

`sysl = upsample(sys,L)` resamples the discrete-time dynamic system model `sys` at a sampling rate that is L -times faster than the sample time of `sys` (T_{s_0}). L must be a positive integer. When `sys` is a TF model, $H(z)$, `upsample` returns `sysl` as $H(z^L)$ with the sample time T_{s_0} / L .

The responses of models `sys` and `sysl` have the following similarities:

- The time responses of `sys` and `sysl` match at multiples of T_{s_0} .
- The frequency responses of `sys` and `sysl` match up to the Nyquist frequency π / T_{s_0} .

Note `sysl` has L times as many states as `sys`.

Examples

Upsample Discrete-Time Transfer Function

Create a transfer function with sample time 2.25 seconds.

```
sys = tf(0.75,[1 10 2],2.25)
```

```
sys =
```

```

      0.75
-----
z^2 + 10 z + 2
```

```
Sample time: 2.25 seconds
Discrete-time transfer function.
```

Create a transfer function with a sample time that is 14 times faster than `sys`.

```
L = 14;
sysl = upsample(sys,L)
```

```
sysl =
```

```

      0.75
-----
z^28 + 10 z^14 + 2
```

```
Sample time: 0.16071 seconds
Discrete-time transfer function.
```

The sample time of `sys1` is 0.16071 seconds, which is 14 times faster than the sample time of `sys`.

Version History

Introduced in R2008b

See Also

`d2d` | `d2c` | `c2d`

varyingGoal

Variable tuning goal for gain-scheduled controllers

Syntax

```
VG = varyingGoal(FH,par1,par2,...)
VG = varyingGoal( ____,Name,Value)
```

Description

When tuning fixed or gain-scheduled controllers at multiple design points (operating conditions), you might need to adjust the tuning goals as a function of operating condition, for example, to relax performance in some regions of the operating range. Use `varyingGoal` to construct tuning goals that depend implicitly or explicitly on the design point.

`VG = varyingGoal(FH,par1,par2,...)` specifies a varying goal using a template and sets of goal-parameter values. The template `FH` is a function handle that specifies a function, `TG = FH(p1,p2,...)`, that evaluates to one of the `TuningGoal` objects. The arrays `par1,par2,...` specify the values of the tuning-goal parameters `p1,p2,...` at each design point. Use `VG` as you would use any `TuningGoal` object in an input to `systune`.

`VG = varyingGoal(____,Name,Value)` configures additional properties of the tuning goal.

Examples

Varying Tuning Goal

Create a tuning goal that specifies variable gain and phase margins across a grid of design points.

Suppose you use the following 5-by-5 grid of design points to tune your controller.

```
[alpha,V] = ndgrid(linspace(0,20,5),linspace(700,1300,5));
```

Suppose further that you have 5-by-5 arrays of target gain margins and target phase margins corresponding to each of the design points, such as the following.

```
[GM,PM] = ndgrid(linspace(7,20,5),linspace(45,70,5));
```

To enforce the specified margins at each design point, first create a template for the margins goal. The template is a function that takes gain and phase margin values and returns a `TuningGoal.Margins` object with those margins.

```
FH = @(gm,pm) TuningGoal.Margins('u',gm,pm);
```

Use the template and the margin arrays to create the varying goal.

```
VG = varyingGoal(FH,GM,PM);
```

To make it easier to trace which goal applies to which design point, use the `SamplingGrid` property to attach the design-point information to `VG`.

```
VG.SamplingGrid = struct('alpha',alpha,'V',V);
```

Use VG with `systune` as you would use any other tuning goal. Use `viewGoal` to visualize the tuning goal and identify design points that fail to meet the target margins.

Varying Tuning Goal With LTI Parameter

Create a tuning goal that specifies a loop shape that varies with one scheduling variable, `a`.

Suppose you want to specify a loop shape with a crossover frequency that varies as $2*a$ over three design points. To enforce this requirement, first create a template for the loop-shape goal. The template is a function that takes a numeric scalar input parameter and returns a `TuningGoal.LoopShape` object. The function input must be scalar, so the function constructs the LTI models representing the loop shapes.

```
a = [5;10;15];
s = tf('s');
FH = @(A) TuningGoal.LoopShape('u',2*A/s);
```

Here, 'u' is an Analysis Point in the system, the location at which you want to impose the loop-shape requirements.

Use the template and the array to create the varying goal.

```
VG = varyingGoal(FH,a);
```

Attach the design-point information to VG.

```
VG.SamplingGrid = struct('a',a);
```

Now each value of `a` is associated with a tuning goal that enforces the corresponding loop shape. For example, confirm that the third entry in `a`, `a = 15`, is associated with the third loop shape, $30/s$.

```
LS3 = getGoal(VG,'index',3);
tf(LS3.LoopGain)
```

```
ans =
```

```
 30
  --
  s
```

Continuous-time transfer function.

Varying Tuning Goal With Frequency Focus and Loop Opening

Create a tuning goal that specifies variable gain and phase margins across a grid of design points. Configure the tuning goal to be evaluated with a loop opening at a location 'LO' and to apply only in the frequency range between 1 and 100 rad/s.

Specify the grid of design points and the corresponding grid of target gain margins and phase margins. Also, create the template function for the varying margins goal.

```
[alpha,V] = ndgrid(linspace(0,20,5),linspace(700,1300,5));
[GM,PM] = ndgrid(linspace(7,20,5),linspace(45,70,5));
FH = @(gm,pm) TuningGoal.Margins('u',gm,pm);
```

Use the template function and the margin arrays to create the varying goal. Also, use `Name`, `Value` pairs to specify:

- The location at which the loop is opened for evaluating the tuning goal (`Openings` property).
- The frequency range in which the varying goal applies (`Focus` property).

The property names and values that you specify for the underlying tuning goal are stored in the `Settings` property of the varying goal.

```
VG = varyingGoal(FH,GM,PM, 'Openings', 'L0', 'Focus', [1,100])
```

```
VG =
    varyingGoal with properties:
        Template: @(gm,pm)TuningGoal.Margins('u',gm,pm)
        Parameters: {[5x5 double] [5x5 double]}
        Settings: {'Openings' 'L0' 'Focus' [1 100]}
        SamplingGrid: [1x1 struct]
        Name: ''
```

Variable tuning goal acting over a 5x5 grid of (gm,pm) values.

To make it easier to trace which goal applies to which design point, use the `SamplingGrid` property to attach the design-point information to VG.

```
VG.SamplingGrid = struct('alpha',alpha,'V',V);
```

Input Arguments

FH — Template for varying goal

function handle

Template for varying goal, specified as a function handle. FH specifies a function of one or more parameters that evaluates to one of the `TuningGoal` objects. For example, suppose you want to constrain the overshoot in the step response from an input `r` to an output `y` in your system, and you want to allow the constraint to vary across different design points. Specify the template as a function that returns a `TuningGoal.Overshoot` object. For example, you can specify FH as an anonymous function.

```
FH = @(os) TuningGoal.Overshoot('r','y',os);
```

Because `TuningGoal.Overshoot` has only one parameter besides the input and output signals, FH is a handle to a function of one argument. For other tuning goals, use more arguments. For example, `TuningGoal.Margins` has two parameters, the gain margin and phase margin. Therefore, for a variable margin goal, FH has two arguments.

```
FH = @(gm,pm) TuningGoal.Margins('u',gm,pm);
```

The template function allows great flexibility in constructing the design goals. For example, you can write a function, `goalspec(a,b)`, that constructs the tuning goal specification as a nontrivial

function of the parameters (a, b), and save the function in a MATLAB file. Your template function then calls `goalspec` as follows.

```
FH = @(a,b) TuningGoal.Margins('u',goalspec(a,b));
```

Similarly, if the tuning-goal parameters do not fit in numeric arrays, you can use the design-point index as input to FH. For example, suppose the gain and phase margin data is stored in a struct array, S, with fields GM and PM, you can use the following.

```
FH = @(idx) TuningGoal.Margins('u',S(idx).GM,S(idx).PM);
```

`idx` is an absolute index into the grid of design points.

par — Tuning goal parameters

numerical array

Tuning goal parameters, specified as a numerical array with the same dimensions as the model array used for gain-scheduled tuning. Provide an array for each parameter in the tuning goal, where each entry in the array is the parameter value you want to apply to the corresponding design point. For example, the `TuningGoal.Overshoot` goal has only one parameter, the maximum overshoot. Therefore, specify the parameters as follows.

```
par = osvls;
```

`osvls` is an array of overshoot values to enforce at each design point.

The `TuningGoal.Margins` goal has two parameters, the gain margin and phase margin. Therefore, for a variable margin goal, specify the parameters as follows:

```
par1 = GM;
par2 = PM;
```

Here, `GM` is an array of gain-margin values and `PM` is an array of phase-margin values to enforce at each design point.

To make the variable tuning goal inactive at a particular design point, set the corresponding entry of the `par` array (or arrays) to `NaN`.

Name-Value Pair Arguments

Specify optional pairs of arguments as `Name1=Value1, ..., NameN=ValueN`, where `Name` is the argument name and `Value` is the corresponding value. Name-value arguments must appear after other arguments, but the order of the pairs does not matter.

Before R2021a, use commas to separate each name and value, and enclose Name in quotes.

Use `Name, Value` pairs to specify properties of the underlying tuning goal. For instance, suppose you want to create a varying gain goal that specifies a variable gain profile between points 'L' and 'V'. You also want to enforce the gain goal only in the frequency band $[0 \text{ pi}/T_s]$, with a loop opening at an analysis point labeled `OuterLoop`. You use `Name, Value` pairs to specify these properties for the gain goal.

```
FH = @(w) TuningGoal.Gain('F','V',tf(w,[1 w]));
VG = varyingGoal(FH,wdata,'Focus',[0 pi/Ts],'Openings','OuterLoop');
```

Which properties you can set depends on which of the `TuningGoal` objects your function FH evaluates to. For instance, for most varying tuning goals, you can set properties such as `Openings`,

Models, and Focus. For a variable `TuningGoal.Gain` goal, you can also use `Name, Value` pairs to set properties such as `Stabilize`, `InputScaling`, and `OutputScaling`. See the individual `TuningGoal` object reference pages for a list of the properties of each tuning goal.

Output Arguments

VG – Variable tuning goal

`varyingGoal` object

Variable tuning goal, returned as a `varyingGoal` object. This object captures the tuning goal and its variation across design points in a MATLAB variable. Use `VG` in an input argument to `systemtune` just as you would use any `TuningGoal` object.

`VG` has the following properties.

Property	Description
Template	Template for the varying goal, stored as a function handle to a function of one or more parameters whose values change over the operating range for tuning. The initial value of this property is set by the <code>FH</code> input argument.
Parameters	<p>Tuning goal parameters at each design point, stored as a cell array. Each entry in the cell array is a numeric array containing the parameter values at each design point. For example, for a variable margins goal with template</p> <pre>FG = FH = @(gm,pm) TuningGoal.Margins('u',gm,pm);</pre> <p>the value of this property is <code>{GM, PM}</code>, where <code>GM</code> and <code>PM</code> are arrays containing the desired gain and phase margins at each design point.</p> <p>The initial value of this property is set by the input arguments <code>par1, par2, ...</code>.</p>
Settings	<p>Property names and values to be applied to each goal instance in the varying goal, stored as a cell array.</p> <p>Default: <code>{}</code></p>

Property	Description
SamplingGrid	<p>Design points, stored as a structure containing an array of values for each sampling variable. The design points need not lie on a rectangular grid and can be scattered throughout the operating range. The sizes of the arrays in the <code>SamplingGrid</code> and <code>Parameters</code> properties must match.</p> <p>For more information about sampling grids, see the <code>SamplingGrid</code> property description on the <code>ss</code> reference page.</p> <p>Default: <code>struct</code> with no fields</p>
Name	<p>Name for the variable goal. Set <code>Name</code> to a string to label the goal.</p> <p>Default: <code>''</code></p>

Tips

- Use `viewGoal` to visualize tuning goals. For varying tuning goals, the tuning-goal plot generated by `viewGoal` lets you examine the tuning goal at each design point. For more information, see “Validate Gain-Scheduled Control Systems”.

Version History

Introduced in R2017b

See Also

`tunableSurface` | `getGoal` | `viewGoal` | `systune`

Topics

“Change Requirements with Operating Condition”
“Validate Gain-Scheduled Control Systems”

viewGoal

View tuning goals; validate design against tuning goals

Syntax

```
viewGoal(Req)  
viewGoal(Req,T)
```

Description

`viewGoal(Req)` displays a graphical view of a tuning goal or vector of tuning goals, specified as `TuningGoal` objects. The form of the tuning-goal plot depends on the specific tuning goals you use. Plots for time-domain tuning goals typically show the target time-domain response specified in the tuning goal. Plots for frequency-domain tuning goals typically show a shaded area that represents the region in which the tuning goal is violated.

When you provide a vector of tuning goals, `viewGoal` plots each tuning goal on separate axes in a single figure window.

`viewGoal(Req,T)` plots the performance of a tuned control system against the tuning goal or goals. The form of the tuning-goal plot depends on the specific tuning goals you use. Typically, the plot shows both the target response specified in the tuning goal and the corresponding response of the control system represented by `T`. For more information about interpreting tuning-goal plots, see “Visualize Tuning Goals”.

Examples

Visualize Tuning Goal as Function of Frequency

Create a tuning goal that constrains the response from a signal 'd' to another signal 'y' to roll off at 20 dB/decade at frequencies greater than 1. The tuning goal also imposes disturbance rejection (maximum gain of 1) in the frequency range [0,1].

```
gmax = frd([1 1 0.01],[0 1 100]);  
Req = TuningGoal.MaxGain('du','u',gmax);
```

When you use a frequency response data (`frd`) model to sketch the bounds of a gain constraint or loop shape, the tuning goal interpolates the constraint. This interpolation converts the constraint to a smooth function of frequency. Examine the interpolated gain constraint using `viewGoal`.

```
viewGoal(Req)
```

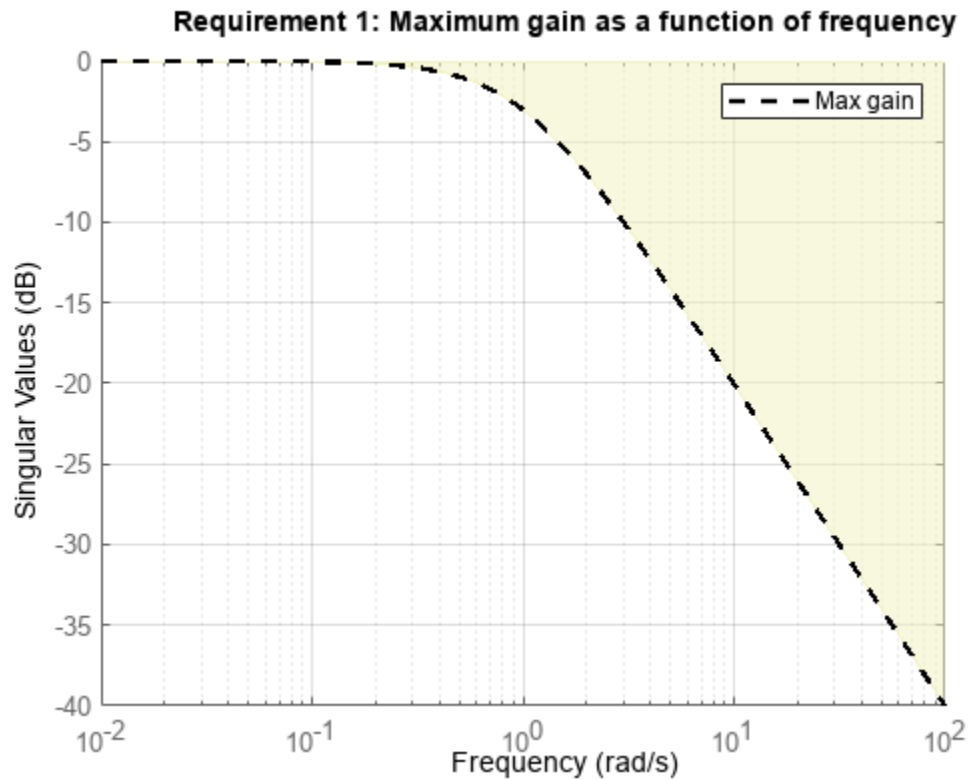
The dotted line shows the gain profile specified in the tuning goal. The shaded region represents gain values that violate the tuning requirement. For more information about interpreting tuning-goal plots, see “Visualize Tuning Goals”.

Visualize Tuned Responses Against Tuning Goals

Examine the tuned response of a control system against tuning goals, to determine where and by how much the tuning goals are violated. This visualization helps you determine whether the tuned control system comes satisfactorily close to meeting your soft requirements.

Open a Simulink® model of a control system to tune.

```
open_system('rct_airframe2')
```

Two-loop autopilot for controlling the vertical acceleration of an airframe

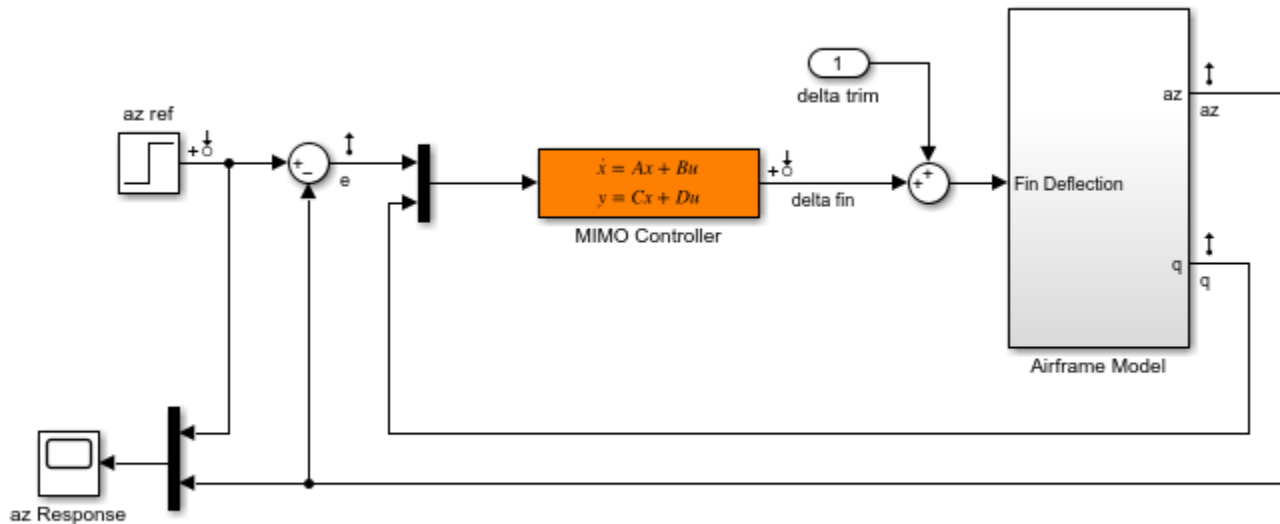

Copyright 2014 The MathWorks, Inc.

Create tuning goals. For this example, use tracking, roll-off, stability margin, and disturbance-rejection tuning goals.

```
Req1 = TuningGoal.Tracking('az ref','az',1);
Req2 = TuningGoal.Gain('delta fin','delta fin',tf(25,[1 0]));
Req3 = TuningGoal.Margins('delta fin',7,45);
MaxGain = frd([2 200 200],[0.02 2 200]);
Req4 = TuningGoal.Gain('delta fin','az',MaxGain);
```

Create an `slTuner` interface, and tune the model with these tuning goals designated as soft goals.

```
ST0 = slTuner('rct_airframe2','MIMO Controller');
addPoint(ST0,'delta fin');
```

```
rng('default');
[ST1,fSoft] = systune(ST0,[Req1,Req2,Req3,Req4]);
```

```
Final: Soft = 1.13, Hard = -Inf, Iterations = 94
```

Verify that the tuned system satisfies the margin requirement.

```
figure;
viewGoal(Req3,ST1)
```

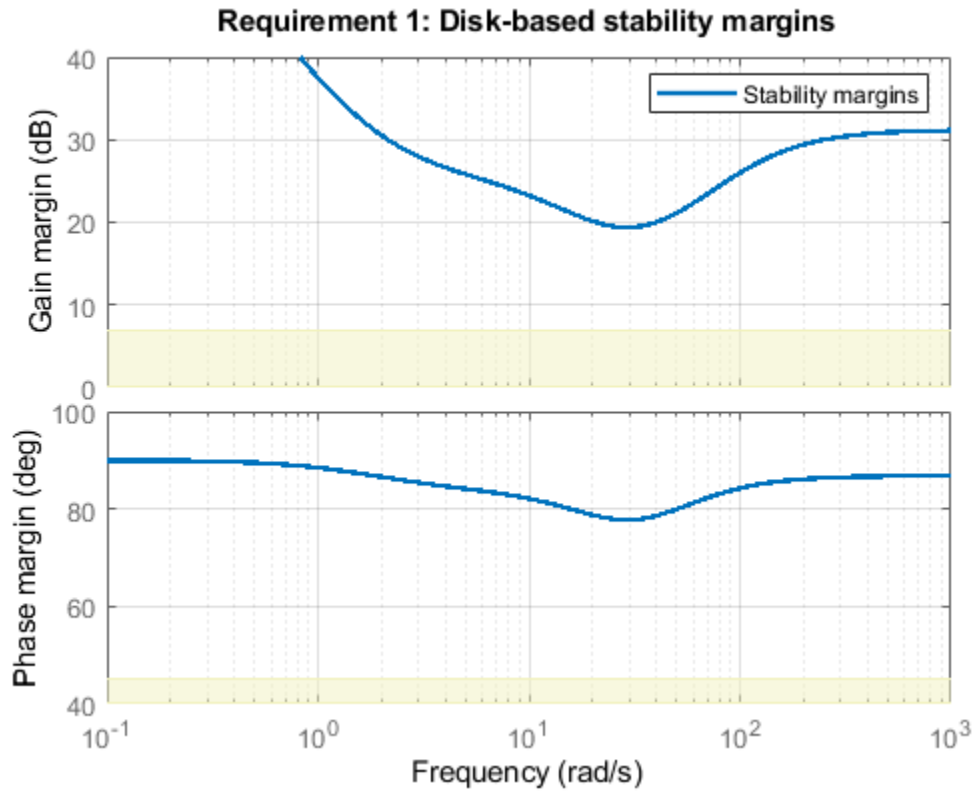

The shaded region corresponds to margins falling short of the target of 7 dB gain margin and 45 degrees phase margin. The solid line shows that the margin requirement is satisfied at all frequencies.

Examine system responses compared to the tracking and disturbance-rejection tuning goals. When you provide a vector of tuning goals, `viewGoal` plots them on separate axes in a single figure.

```
figure
viewGoal([Req1,Req4],ST1)
```

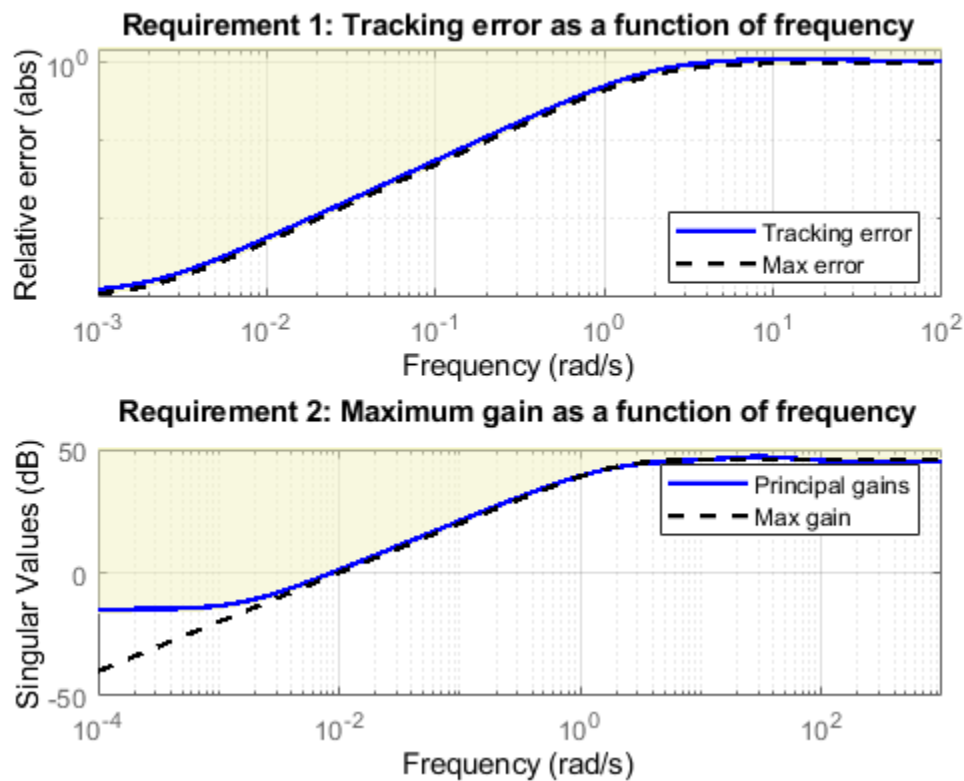

The first plot shows that the tuned system response very nearly satisfies the tracking requirement. The slight violation suggests that setpoint tracking will perform close to expectations.

The second plot shows that the gain requirement is satisfied except at low frequency. For this tuning goal, the shaded region, which represents the effective tuning constraint, diverges from the specified maximum gain profile at low frequency. This modification to the gain profile is to avoid a pole at $s = 0$ in the weighting function used to normalize the goal (see Tips on this page). While the tuned gain exceeds the specified gain below 0.001 rad/s, it is still about 60 dB less than the peak value, which is typically enough in practice.

To further examine the responses of the tuned system, use `getIOTransfer` to extract the relevant transfer functions for analysis with time-domain commands such as `step`.

Input Arguments

Req — Tuning goal to view or validate

TuningGoal object | vector of TuningGoal objects

Tuning goal to view or validate, specified as a TuningGoal object or vector of TuningGoal objects. For a list of all TuningGoal objects, see “Tuning Goals”.

T — Tuned control system

generalized state-space model | sLTuner interface object

Tuned control system, specified as a generalized state-space (`genss`) model or an `sLTuner` interface to a Simulink model. `T` is typically the result of using the tuning goal to tune control system parameters with `systemtune`.

Example: `[T, fSoft, gHard] = systemtune(T0, SoftReq, HardReq)`, where `T0` is a tunable `genss` model

Example: `[T, fSoft, gHard] = systemtune(ST0, SoftReq, HardReq)`, where `ST0` is a `sLTuner` interface object

Tips

- For general information about how to interpret tuning-goal plots, see “Visualize Tuning Goals”. For information about interpreting margin-goal plots in particular, see “Stability Margins in Control System Tuning”.
- For varying tuning goals that you create with `varyingGoal`, the tuning-goal plot generated by `viewGoal` lets you examine the tuning goal at each design point. For more information, see “Validate Gain-Scheduled Control Systems”.
- With some frequency-domain tuning goals, there might be a difference between the gain profile you specify in the tuning goal (dashed line), and the profile the software uses for tuning (shaded region). In this case, the shaded region of the plot reflects the profile that the software uses for tuning. The gain profile you specify and the gain profile used for tuning might differ if:
 - You tune a control system in discrete time, but specify the gain profile in continuous time.
 - The software modifies the asymptotes of the specified gain profile to improve numeric stability.

For more information about how an enforced tuning goal might differ from the goal, see “Visualize Tuning Goals”.

- For MIMO feedback loops, the `LoopShape`, `MinLoopGain`, `MaxLoopGain`, `Margins`, `Sensitivity`, and `Rejection` goals are sensitive to the relative scaling of each SISO loop. `systemtune` tries to balance the overall loop-transfer matrix while enforcing such goals. The optimal loop scaling is stored in the tuned closed-loop model or `sLTuner` interface `T` returned by `systemtune`. For consistency, `viewGoal(R, T)` takes this scaling into account, and plots the scaled open-loop response or sensitivity. To omit this scaling, use `viewGoal(R, clearTuningInfo(T))`.

Modifying `T` might compromise the validity of the stored scaling. Therefore, if you make significant modifications to `T`, retuning is recommended to update the scaling data.

Version History

Introduced in R2012b

See Also

`systemtune` | `genss` | `evalGoal` | `systemtune` (for `sLTuner`)

Topics

“Visualize Tuning Goals”

“Stability Margins in Control System Tuning”

“Tuning Goals”

viewSpec

(Not recommended) View tuning goals; validate design against tuning goals

Note `viewSpec` is not recommended. Use `viewGoal` instead.

Syntax

```
viewSpec(Req)
viewSpec(Req,T)
viewSpec(Req,T,[])
```

Description

`viewSpec(Req)` displays a graphical view of a tuning goal or vector of tuning goals, specified as `TuningGoal` objects. The form of the tuning-goal plot depends on the specific tuning goals you use. Plots for time-domain tuning goals typically show the target time-domain response specified in the tuning goal. Plots for frequency-domain tuning goals typically show a shaded area that represents the region in which the tuning goal is violated.

When you provide a vector of tuning goals, `viewSpec` plots each tuning goal on separate axes in a single figure window.

`viewSpec(Req,T)` plots the performance of a tuned control system against the tuning goal or goals. The form of the tuning-goal plot depends on the specific tuning goals you use. Typically, the plot shows both the target response specified in the tuning goal and the corresponding response of the control system represented by `T`. For more information about interpreting tuning-goal plots, see “Visualize Tuning Goals”.

`viewSpec(Req,T,[])` disregards scaling information stored with the tuned control system `T` when computing system responses. For more information, see “Tips” on page 2-1513.

Examples

Visualize Tuning Goal as Function of Frequency

Create a tuning goal that constrains the response from a signal 'd' to another signal 'y' to roll off at 20 dB/decade at frequencies greater than 1. The tuning goal also imposes disturbance rejection (maximum gain of 1) in the frequency range [0,1].

```
gmax = frd([1 1 0.01],[0 1 100]);
Req = TuningGoal.MaxGain('du','u',gmax);
```

When you use a frequency response data (`frd`) model to sketch the bounds of a gain constraint or loop shape, the tuning goal interpolates the constraint. This interpolation converts the constraint to a smooth function of frequency. Examine the interpolated gain constraint using `viewSpec`.

```
viewSpec(Req)
```

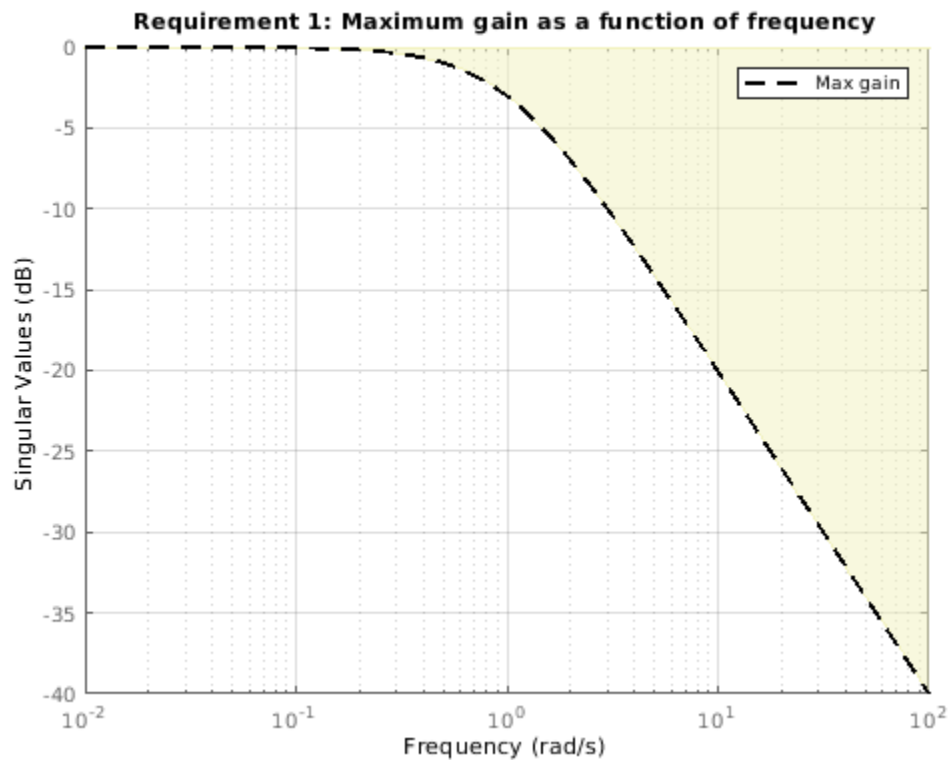

The dotted line shows the gain profile specified in the tuning goal. The shaded region represents gain values that violate the tuning requirement. For more information about interpreting tuning-goal plots, see “Visualize Tuning Goals”.

Visualize Tuned Responses Against Tuning Goals

Examine the tuned response of a control system against tuning goals, to determine where and by how much the tuning goals are violated. This visualization helps you determine whether the tuned control system comes satisfactorily close to meeting your soft requirements.

Open a Simulink® model of a control system to tune.

```
open_system('rct_airframe2')
```

Two-loop autopilot for controlling the vertical acceleration of an airframe

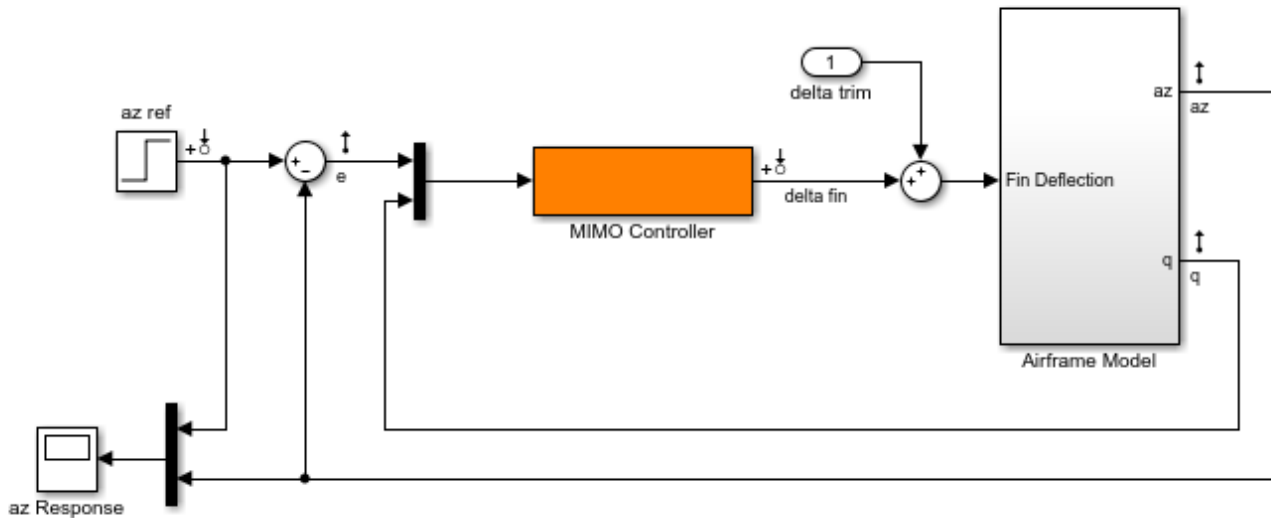

Create tuning goals. For this example, use tracking, roll-off, stability margin, and disturbance-rejection tuning goals.

```
Req1 = TuningGoal.Tracking('az ref','az',1);
Req2 = TuningGoal.Gain('delta fin','delta fin',tf(25,[1 0]));
Req3 = TuningGoal.Margins('delta fin',7,45);
MaxGain = frd([2 200 200],[0.02 2 200]);
Req4 = TuningGoal.Gain('delta fin','az',MaxGain);
```

Create an sLTuner interface, and tune the model with these tuning goals designated as soft goals.

```
ST0 = sLTuner('rct_airframe2','MIMO Controller');
addPoint(ST0,'delta fin');
```

```
rng('default');
[ST1,fSoft] = systune(ST0,[Req1,Req2,Req3,Req4]);
```

```
Final: Soft = 1.13, Hard = -Inf, Iterations = 68
```

Verify that the tuned system satisfies the margin requirement.

```
figure;
viewSpec(Req3,ST1)
```

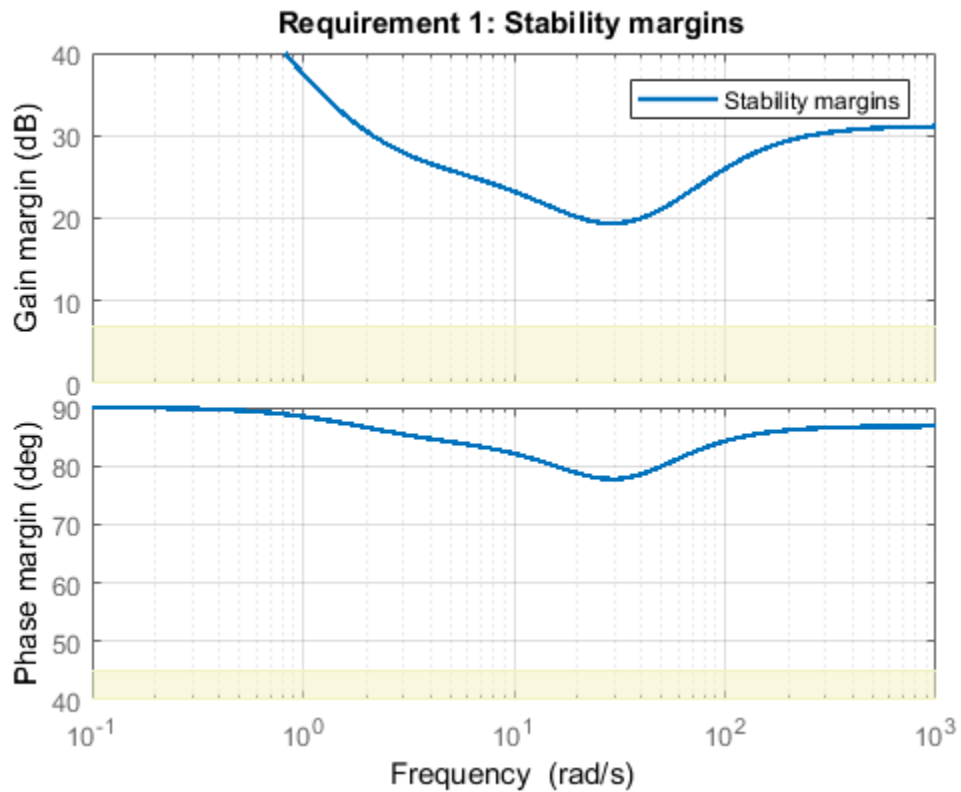
The shaded region corresponds to margins falling short of the target of 7 dB gain margin and 45 degrees phase margin. The solid line shows that the margin requirement is satisfied at all frequencies.

Examine system responses compared to the tracking and disturbance-rejection tuning goals. When you provide a vector of tuning goals, `viewSpec` plots them on separate axes in a single figure.

```
figure
viewSpec([Req1,Req4],ST1)
```

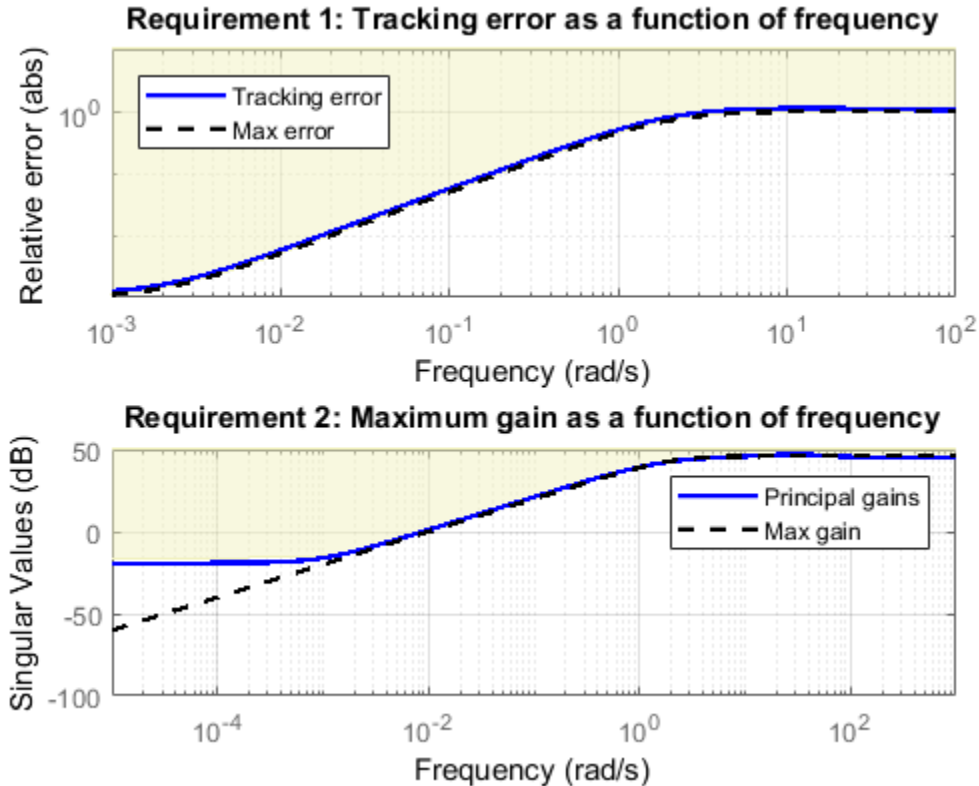

The first plot shows that the tuned system response very nearly satisfies the tracking requirement. The slight violation suggests that setpoint tracking will perform close to expectations.

The second plot shows that the gain requirement is satisfied except at low frequency. For this tuning goal, the shaded region, which represents the effective tuning constraint, diverges from the specified maximum gain profile at low frequency. This modification to the gain profile is to avoid a pole at $s = 0$ in the weighting function used to normalize the goal (see “Tips” on page 2-1513). While the tuned gain exceeds the specified gain below 0.001 rad/s, it is still about 60 dB less than the peak value, which is typically enough in practice.

To further examine the responses of the tuned system, use `getIOTransfer` to extract the relevant transfer functions for analysis with time-domain commands such as `step`.

Input Arguments

Req — Tuning goal to view or validate

TuningGoal object | vector of TuningGoal objects

Tuning goal to view or validate, specified as a TuningGoal object or vector of TuningGoal objects. For a list of all TuningGoal objects, see “Tuning Goals”.

T — Tuned control system

generalized state-space model | sLTuner interface object

Tuned control system, specified as a generalized state-space (`genss`) model or an `sITuner` interface to a Simulink model. `T` is typically the result of using the tuning goal to tune control system parameters with `sytune`.

Example: `[T, fSoft, gHard] = systune(T0, SoftReq, HardReq)`, where `T0` is a tunable `genss` model

Example: `[T, fSoft, gHard] = systune(ST0, SoftReq, HardReq)`, where `ST0` is a `sITuner` interface object

Tips

- With some frequency-domain tuning goals, there might be a difference between the gain profile you specify in the tuning goal (dashed line), and the profile the software uses for tuning (shaded region). In this case, the shaded region of the plot reflects the profile that the software uses for tuning. The gain profile you specify and the gain profile used for tuning might differ if:
 - You tune a control system in discrete time, but specify the gain profile in continuous time.
 - The software modifies the asymptotes of the specified gain profile to improve numeric stability.

For more information about how an enforced tuning goal might differ from the goal, see “Visualize Tuning Goals”.

- For MIMO feedback loops, the `LoopShape`, `MinLoopGain`, `MaxLoopGain`, `Margins`, `Sensitivity`, and `Rejection` goals are sensitive to the relative scaling of each SISO loop. `sytune` tries to balance the overall loop-transfer matrix while enforcing such goals. The optimal loop scaling is stored in the tuned closed-loop model `CL` returned by `sytune`. For consistency, `viewSpec(R, CL)` takes this scaling into account, and plots the scaled open-loop response or sensitivity. To omit this scaling, use `viewSpec(R, CL, [])`.

Modifying `CL` might compromise the validity of the stored scaling. Therefore, if you make significant modifications to `CL`, retuning is recommended to update the scaling data.

Version History

Introduced in R2012b

viewSpec is not recommended

Not recommended starting in R2017b

Beginning in R2017b, `viewSpec` is not recommended. Use `viewGoal` instead.

See Also

`sytune` | `genss` | `evalGoal` | `viewGoal` | `sytune` (for `sITuner`)

Topics

“Visualize Tuning Goals”

“Tuning Goals”

viewSurf

Visualize gain surface as a function of scheduling variables

Syntax

```
viewSurf(GS)
viewSurf(GS,xvar,xdata)
viewSurf(GS,xvar,xdata,yvar,ydata)
```

Description

`viewSurf(GS)` plots the values of a 1-D or 2-D gain surface as a function of the scheduling variables. `GS` is a tunable gain surface that you create with `tunableSurface`. The plot uses the independent variable values specified in `GS.SamplingGrid`. For 2-D gain surfaces, the design points in `GS.SamplingGrid` must lie on a rectangular grid.

`viewSurf(GS,xvar,xdata)` plots the gain surface `GS` at the scheduling-variable values listed in `xdata`. The variable name `xvar` must match a scheduling variable name in `GS.SamplingGrid`. However, the values in `xdata` need not match design points in `GS.SamplingGrid`.

For a 2-D gain surface, the plot shows a parametric family of curves with one curve per value of the other scheduling variable. In the 2-D case, the design points in `GS.SamplingGrid` must lie on a rectangular grid.

`viewSurf(GS,xvar,xdata,yvar,ydata)` creates a surface plot of a 2-D gain surface evaluated over a grid of scheduling variable values given by `ndgrid(xdata,ydata)`. In this case, the design points of `GS` do not need to lie on a rectangular grid, and `xdata` and `ydata` do not need to match the design points.

Examples

View Gain Surface

Display a tunable gain surface that depends on two independent variables.

Model a scalar gain K with a bilinear dependence on two scheduling variables, α and V , as follows:

$$K(\alpha, V) = K_0 + K_1x + K_2y + K_3xy.$$

Here, x and y are the normalized scheduling variables. Suppose that α is an angle of incidence that ranges from 0 degrees to 15 degrees, and V is a speed that ranges from 300 m/s to 600 m/s. Then, x and y are given by:

$$x = \frac{\alpha - 7.5}{7.5}, \quad y = \frac{V - 450}{150}.$$

The coefficients K_0, \dots, K_3 are the tunable parameters of this variable gain. Use `tunableSurface` to model this variable gain.

```
[alpha,V] = ndgrid(0:1.5:15,300:30:600);
domain = struct('alpha',alpha,'V',V);
shapefcn = @(x,y) [x,y,x*y];
K = tunableSurface('K',1,domain,shapefcn);
```

Typically, you would tune the coefficients as part of a control system. You would then use `setBlockValue` or `setData` to write the tuned coefficients back to `K`, and view the tuned gain surface. For this example, instead of tuning, manually set the coefficients to non-zero values and view the resulting gain.

```
Ktuned = setData(K,[100,28,40,10]);
viewSurf(Ktuned)
```

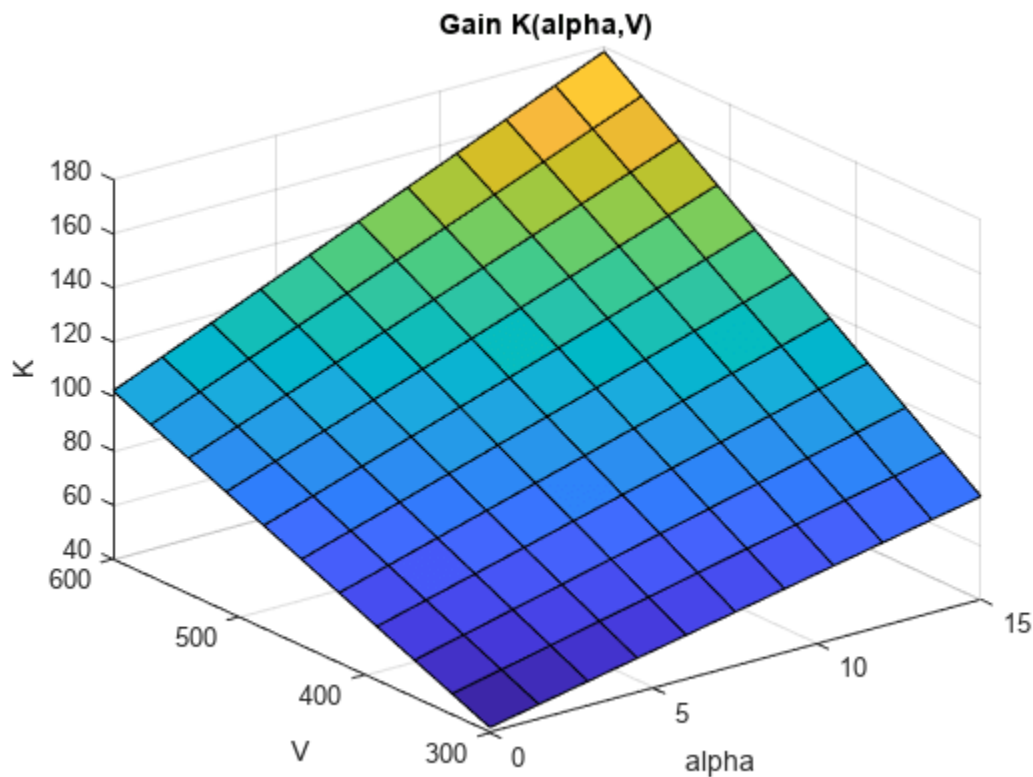

`viewSurf` displays the gain surface as a function of the scheduling variables, for the ranges of values specified by `domain` and stored in `Ktuned.SamplingGrid`.

Plot Gain Surface for Specified Breakpoints

View a 1-D gain surface evaluated at different design points from the points specified in the gain surface.

When you create a gain surface using `tunableSurface`, you specify design points at which the gain coefficients are tuned. These points are typically the scheduling-variable values at which you have sampled or linearized the plant. However, you might want to implement the gain surface as a lookup

table with breakpoints that are different from the specified design points. In this example, you create a gain surface with a set of design points and then view the surface using a different set of scheduling variable values.

Create a scalar gain that varies as a quadratic function of one scheduling variable, t . Suppose that you have linearized your plant every five seconds from $t = 0$ to $t = 40$.

```
t = 0:5:40;
domain = struct('t',t);
shapefcn = @(x) [x,x^2];
GS = tunableSurface('GS',1,domain,shapefcn);
```

Typically, you would tune the coefficients as part of a control system. For this example, instead of tuning, manually set the coefficients to non-zero values.

```
GS = setData(GS,[12.1,4.2,2]);
```

Plot the gain surface evaluated at a different set of time values.

```
tvals = [0,4,11,18,25,32,39,42];
viewSurf(GS,'t',tvals)
```

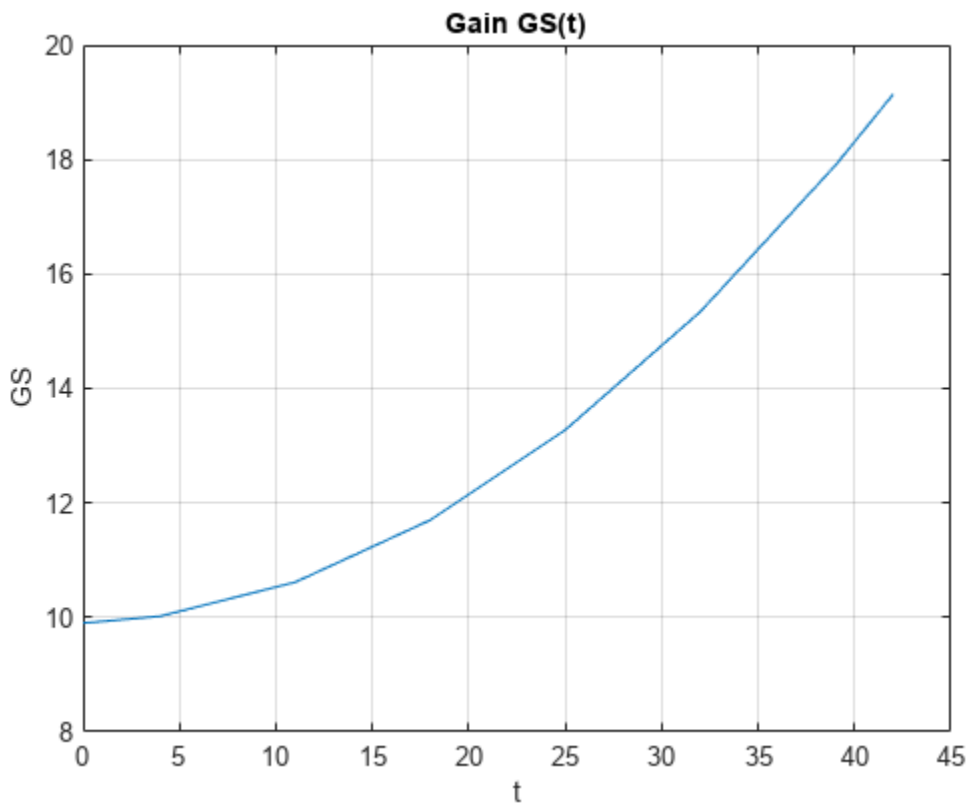

The plot shows that the gain curve bends at the points specified in `tvals`, rather than the design points specified in `domain`. Also, `tvals` includes values outside of the scheduling-variable range of `domain`. If you attempt to extrapolate too far out of the range of values used for tuning, the software issues a warning.

View 1-Dimensional Projections of 2-D Gain Surface

Plot gain surface values as a function of one independent variable, for a gain surface that depends on two independent variables.

Create a gain surface that is a bilinear function of two independent variables, α and V .

```
[alpha,V] = ndgrid(0:1.5:15,300:30:600);
domain = struct('alpha',alpha,'V',V);
shapefcn = @(x,y) [x,y,x*y];
GS = tunableSurface('GS',1,domain,shapefcn);
```

Typically, you would tune the coefficients as part of a control system. For this example, instead of tuning, manually set the coefficients to non-zero values.

```
GS = setData(GS,[100,28,40,10]);
```

Plot the gain at selected values of V .

```
Vplot = [300:50:600];
viewSurf(GS,'V',Vplot);
```

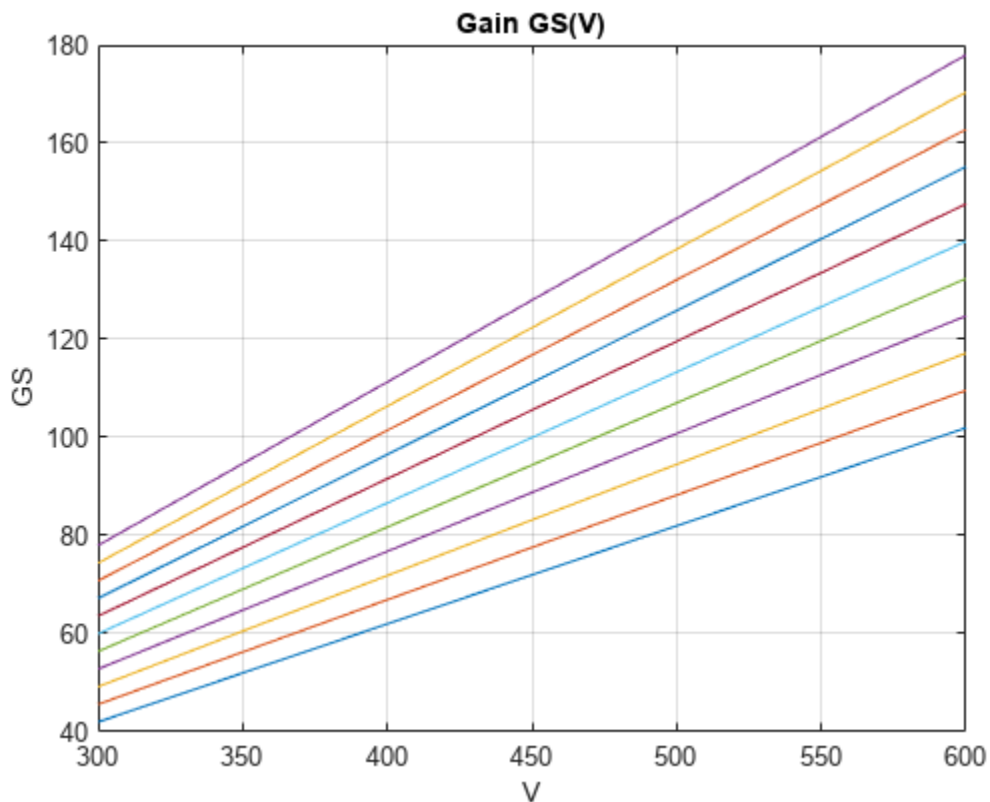

`viewSurf` evaluates the gain surface at the specified values of V , and plots the dependence on V for all values of α in `domain`. Clicking any of the lines in the plot displays the corresponding α value. This plot is useful to visualize the full range of gain variation due to one independent variable.

Plot 2-D Gain Surface for Specified Breakpoints

View a 2-D gain surface evaluated at different scheduling-variable values from the design points specified in the gain surface.

When you create a gain surface using `tunableSurface`, you specify design points at which the gain coefficients are tuned. These points are typically the scheduling-variable values at which you have sampled or linearized the plant. However, you might want to implement the gain surface as a lookup table with breakpoints that are different from the specified design points. In this example, you create a gain surface with a set of design points and then view the surface using a different set of scheduling-variable values.

Create a gain surface that is a bilinear function of two independent variables, α and V .

```
[alpha,V] = ndgrid(0:1.5:15,300:30:600);  
domain = struct('alpha',alpha,'V',V);  
shapefcn = @(x,y) [x,y,x*y];  
GS = tunableSurface('GS',1,domain,shapefcn);
```

Typically, you would tune the coefficients as part of a control system. For this example, instead of tuning, manually set the coefficients to non-zero values.

```
GS = setData(GS,[100,28,40,10]);
```

Plot the gain at selected values of α and V .

```
alpha_vec = [7:1:13];  
V_vec = [500:25:625];  
viewSurf(GS,'alpha',alpha_vec,'V',V_vec);
```

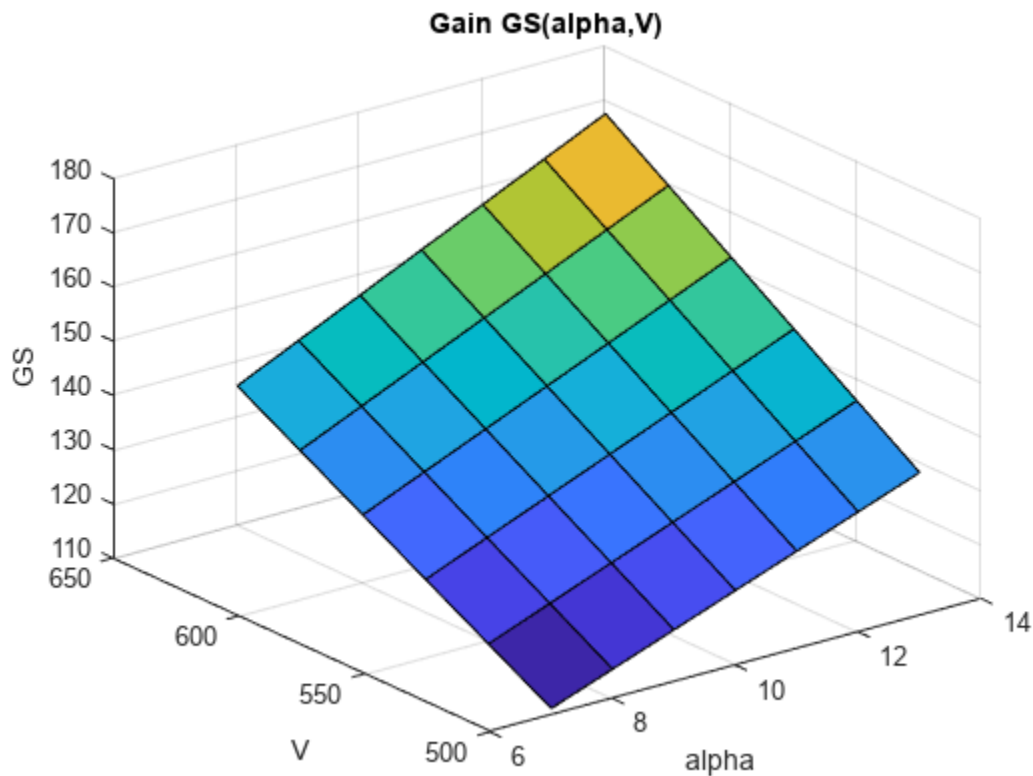
The breakpoints at which you evaluate the gain surface need not fall within the range specified by domain. However, if you attempt to evaluate the gain too far outside the range used for tuning, the software issues a warning.

The breakpoints also need not be regularly spaced. In addition, you can specify the scheduling variables in any order to get a different perspective on the shape of the surface. The variable that you specify first is used as the X-axis in the plot.

```
alpha_vec2 = [1,3,6,10,15];
V_vec2 = [300,350,425,575];
viewSurf(GS, 'V',V_vec2, 'alpha',alpha_vec2);
```

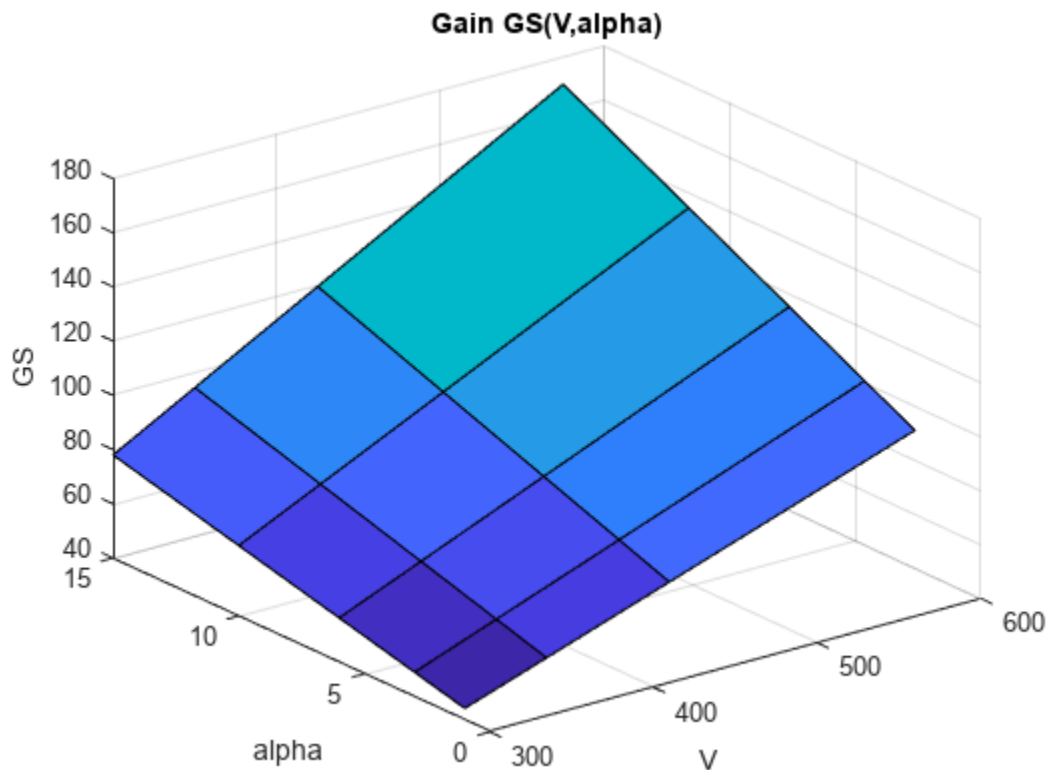

Input Arguments

GS — Gain surface

tunableSurface object

Gain surface to plot, specified as a tunableSurface object. GS can depend on one or two scheduling variables, and must be scalar-valued.

xvar — X-axis variable

character vector

X-axis variable in the plot, specified as a character vector. The variable name xvar must match a scheduling variable name in GS.SamplingGrid.

xdata — X-axis-variable values

numeric vector

X-axis-variable values at which to evaluate and plot the gain surface, specified as a numeric vector.

yvar — Y-axis variable

character vector

Y-axis variable in the plot, specified as a character vector. The variable name yvar must match a scheduling variable name in GS.SamplingGrid.

ydata — Y-axis-variable values

numeric vector

Y-axis-variable values at which to evaluate and plot the gain surface, specified as a numeric vector.

Version History**Introduced in R2015b****See Also**

tunableSurface | evalSurf

voidModel

Mark missing or irrelevant models in model array

Syntax

```
Mout = voidModel(M,void)
```

Description

`Mout = voidModel(M,void)` sets the models specified by `void` to NaN static gains. When working with model arrays defined on a multidimensional grid of design points, use `voidModel` to indicate that no model is available at specific grid points. For example, when using `systemtune` to tune controller parameters for a model array, remove models at points outside the design envelope or points to be ignored during analysis or design.

- If `void` is a vector of integers, then `voidModel` sets `M(:, :, void)` to NaN.
- If `void` is a logical array, then `voidModel` sets the models selected by `void` to NaN.

Examples

Mark Unneeded Models in Array

Generate an array of tunable `genss` models. To do so, first create an array of plant models by varying parameters in a second-order transfer function. Then, interconnect the resulting array of plant models with a tunable controller element.

```
G = tf(zeros(1,1,3,3));
zeta = [0.66,0.71,0.75];
w = [1.0,1.2,1.5];
for i = 1:length(zeta)
    for j = 1:length(w)
        G(:, :, i, j) = tf(w(j)^2, [1 2*zeta(i)*w(j) w(j)^2]);
    end
end
```

```
C = tunablePID('C', 'PID');
M = feedback(C*G,1)
```

M =

```
3x3 array of generalized continuous-time state-space models.
Each model has 1 outputs, 1 inputs, 3 states, and the following blocks:
C: Tunable PID controller, 1 occurrences.
```

Type `"ss(M)"` to see the current value, `"get(M)"` to see all properties, and `"M.Blocks"` to interact

Suppose that you want to tune the PID controller gains for all of the models in `M`, but that the parameter combinations $(zeta, w) = (0.66, 1.0)$ and $(zeta, w) = (0.75, 1.5)$ do not occur in your physical system. Void these models so that they do not contribute to any tuning or analysis of the

model array. These models are the first and last models in the 3-by-3 array, with linear indices 1 and 9.

```
void = [1,9]
```

```
void = 1×2
```

```
     1     9
```

```
Mout = voidModel(M,void)
```

```
Mout =
```

```
3x3 array of generalized continuous-time state-space models.
```

```
Each model has 1 outputs, 1 inputs, between 0 and 3 states, and between 0 and 1 blocks.
```

```
Type "ss(Mout)" to see the current value, "get(Mout)" to see all properties, and "Mout.Blocks" to
```

The display indicates that the models in `Mout` have 0-3 states and 0-1 blocks. The 0-state, 0-block models are the voided entries in `Mout`. For instance, examine the first entry and confirm that it is a NaN static gain.

```
tf(Mout(:,:,1,1))
```

```
ans =
```

```
NaN
```

```
Static gain.
```

Instead of using linear indices to specify the models to void, you can use a logical array.

```
void = logical([1 0 0;0 0 0;0 0 1]);
```

```
Mout1 = voidModel(M,void);
```

Confirm that the first and last models in `Mout1` are NaN.

```
tf(Mout1(:,:,1,1))
```

```
ans =
```

```
NaN
```

```
Static gain.
```

```
tf(Mout1(:,:,3,3))
```

```
ans =
```

```
NaN
```

```
Static gain.
```

Input Arguments

M — Model array

LTI model array

Model array, specified as an LTI model array such as an array of `genss` models.

void — Models to void

vector | logical array

Models to void, specified as a vector of integer values or a logical array.

- If `void` is a vector of integers, then `voidModel` sets `M(:, :, void)` to `NaN`. For instance, using `Void = [1, 10]` voids `M(:, :, [1 10])`, the 1st and 10th models in `M` determined by linear indexing, regardless of the array dimensions of `M`.
- If `void` is a logical array, then `voidModel` sets the models selected by `void` to `NaN`. For instance, if `M` is a 2-by-2 array of models, then using `void = logical([0, 1; 0, 0])` voids the second model in the first row of `M`.

Output Arguments**Mout — Array with voided models**

LTI model array

Array with voided models set to `NaN`, returned as an LTI model array of the same type and size as `M`.

Version History

Introduced in R2017b

See Also

xperm

Reorder states in state-space models

Syntax

```
sys = xperm(sys,P)
```

Description

`sys = xperm(sys,P)` reorders the states of the state-space model `sys` according to the permutation `P`. The vector `P` is a permutation of `1:NX`, where `NX` is the number of states in `sys`. For information about creating state-space models, see `ss` and `dss`.

Examples

Alphabetically Order States of State-Space Model

Load a previously saved state space model `ssF8` with four states.

```
load ltiexamples
```

```
ssF8
```

```
ssF8 =
```

```
A =
```

	PitchRate	Velocity	AOA	PitchAngle
PitchRate	-0.7	-0.0458	-12.2	0
Velocity	0	-0.014	-0.2904	-0.562
AOA	1	-0.0057	-1.4	0
PitchAngle	1	0	0	0

```
B =
```

	Elevator	Flaperon
PitchRate	-19.1	-3.1
Velocity	-0.0119	-0.0096
AOA	-0.14	-0.72
PitchAngle	0	0

```
C =
```

	PitchRate	Velocity	AOA	PitchAngle
FlightPath	0	0	-1	1
Acceleration	0	0	0.733	0

```
D =
```

	Elevator	Flaperon
FlightPath	0	0
Acceleration	0.0768	0.1134

Continuous-time state-space model.

Order the states in alphabetical order.

```
[y,P] = sort(ssF8.StateName);
sys = xperm(ssF8,P)

sys =

A =

      AOA  PitchAngle  PitchRate  Velocity
AOA      -1.4         0         1      -0.0057
PitchAngle  0         0         1         0
PitchRate  -12.2        0       -0.7     -0.0458
Velocity  -0.2904     -0.562        0     -0.014

B =

      Elevator  Flaperon
AOA      -0.14   -0.72
PitchAngle  0     0
PitchRate  -19.1  -3.1
Velocity  -0.0119 -0.0096

C =

      AOA  PitchAngle  PitchRate  Velocity
FlightPath  -1         1         0         0
Acceleration  0.733        0         0         0

D =

      Elevator  Flaperon
FlightPath  0     0
Acceleration  0.0768  0.1134
```

Continuous-time state-space model.

The states in `ssF8` now appear in alphabetical order.

Version History

Introduced in R2008b

See Also

`ss` | `dss`

xsort

Sort states based on state partition

Syntax

```
xsys = xsort(sys)
```

Description

`xsys = xsort(sys)` sorts the `x` or `q` vector based on the state partition. Signal-based connections and physical interfaces between model components gives rise to differential algebraic equation (DAE) models where some internal signals and forces become extra states. The `StateInfo` property of `sparss` and `mechss` model objects keeps track of the state partition into sub-components, interface variables, and signal variables.

Examples

Sparse Second-Order Model in a Feedback Loop

For this example, consider `sparseSOSignal.mat` that contains a sparse second-order model. Define an actuator, sensor, and controller and connect them together with the plant in a feedback loop.

Load the sparse matrices and create the `mechss` object.

```
load sparseSOSignal.mat
plant = mechss(M,C,K,B,F,[],[], 'Name', 'Plant');
```

Next, create an actuator and sensor using transfer functions.

```
act = tf(1,[1 0.5 3], 'Name', 'Actuator');
sen = tf(1,[0.02 7], 'Name', 'Sensor');
```

Create a PID controller object for the plant.

```
con = pid(1,1,0.1,0.01, 'Name', 'Controller');
```

Use the `feedback` command to connect the plant, sensor, actuator, and controller in a feedback loop.

```
sys = feedback(sen*plant*act*con,1)
```

Sparse continuous-time second-order model with 1 outputs, 1 inputs, and 7111 degrees of freedom.

Use `"spy"` and `"showStateInfo"` to inspect model structure.

Type `"properties('mechss')"` for a list of model properties.

Type `"help mechssOptions"` for available solver options for this model.

The resultant system `sys` is a `mechss` object since `mechss` objects take precedence over all other model object types.

Use `showStateInfo` to view the component and signal groups.

```
showStateInfo(sys)
```

The state groups are:

Type	Name	Size
Component	Sensor	1
Component	Plant	7102
Signal		1
Component	Actuator	2
Signal		1
Component	Controller	2
Signal		1
Signal		1

Use `xsort` to sort the components and signals, and then view the component and signal groups.

```
sysSort = xsort(sys);  
showStateInfo(sysSort)
```

The state groups are:

Type	Name	Size
Component	Sensor	1
Component	Plant	7102
Component	Actuator	2
Component	Controller	2
Signal		4

Observe that the components are now ordered before the signal partition. The signals are now sorted and grouped together in a single partition.

You can also visualize the sparsity pattern of the resultant system using `spy`.

```
spy(sysSort)
```

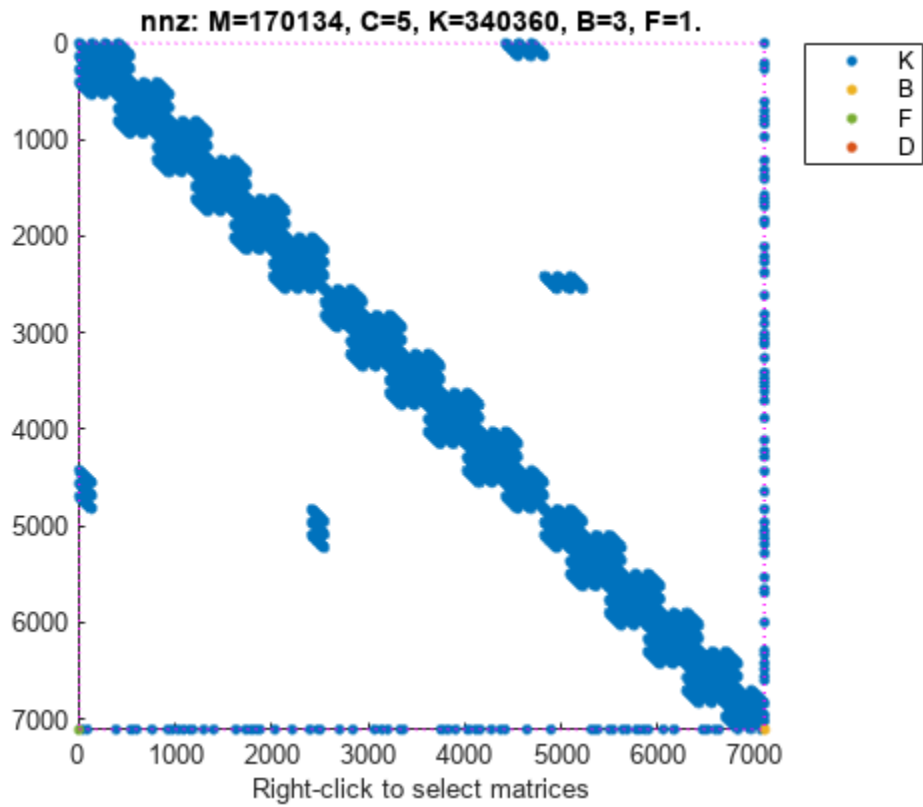

Physical Connections Between Components in Sparse Second-Order Model

For this example, consider a structural model that consists of two square plates connected with pillars at each vertex as depicted in the figure below. The lower plate is attached rigidly to the ground while the pillars are attached rigidly to each vertex of the square plate.

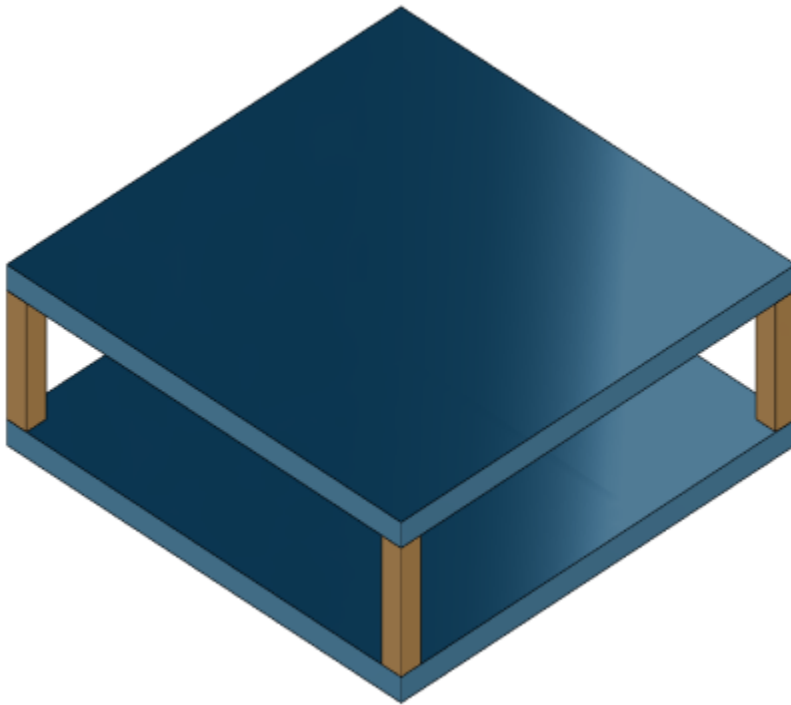

Load the finite element model matrices contained in `platePillarModel.mat` and create the sparse second-order model representing the above system.

```
load('platePillarModel.mat')
model = ...
    mechss(M1,[],K1,B1,F1,'Name','Plate1') + ...
    mechss(M2,[],K2,B2,F2,'Name','Plate2') + ...
    mechss(Mp,[],Kp,Bp,Fp,'Name','Pillar3') + ...
    mechss(Mp,[],Kp,Bp,Fp,'Name','Pillar4') + ...
    mechss(Mp,[],Kp,Bp,Fp,'Name','Pillar5') + ...
    mechss(Mp,[],Kp,Bp,Fp,'Name','Pillar6');
sys = model;
```

Use `showStateInfo` to examine the components of the `mechss` model object.

```
showStateInfo(sys)
```

The state groups are:

Type	Name	Size
Component	Plate1	2646
Component	Plate2	2646
Component	Pillar3	132
Component	Pillar4	132
Component	Pillar5	132
Component	Pillar6	132

Now, load the interfaced degree of freedom (DOF) index data from `dofData.mat` and use `interface` to create the physical connections between the two plates and the four pillars. `dofs` is a 6x7 cell array where the first two rows contain DOF index data for the first and second plates while the remaining four rows contain index data for the four pillars. By default, the function uses dual-assembly method of physical coupling.

```
load('dofData.mat','dofs')
for i=3:6
    sys = interface(sys,"Plate1",dofs{1,i},"Pillar"+i,dofs{i,1});
    sys = interface(sys,"Plate2",dofs{2,i},"Pillar"+i,dofs{i,2});
end
```

Specify connection between the bottom plate and the ground.

```
sysConDual = interface(sys,"Plate2",dofs{2,7});
```

Use `showStateInfo` to confirm the physical interfaces.

```
showStateInfo(sysConDual)
```

The state groups are:

Type	Name	Size
-----	-----	-----
Component	Plate1	2646
Component	Plate2	2646
Component	Pillar3	132
Component	Pillar4	132
Component	Pillar5	132
Component	Pillar6	132
Interface	Plate1-Pillar3	12
Interface	Plate2-Pillar3	12
Interface	Plate1-Pillar4	12
Interface	Plate2-Pillar4	12
Interface	Plate1-Pillar5	12
Interface	Plate2-Pillar5	12
Interface	Plate1-Pillar6	12
Interface	Plate2-Pillar6	12
Interface	Plate2-Ground	6

You can use `spy` to visualize the sparse matrices in the final model.

```
spy(sysConDual)
```

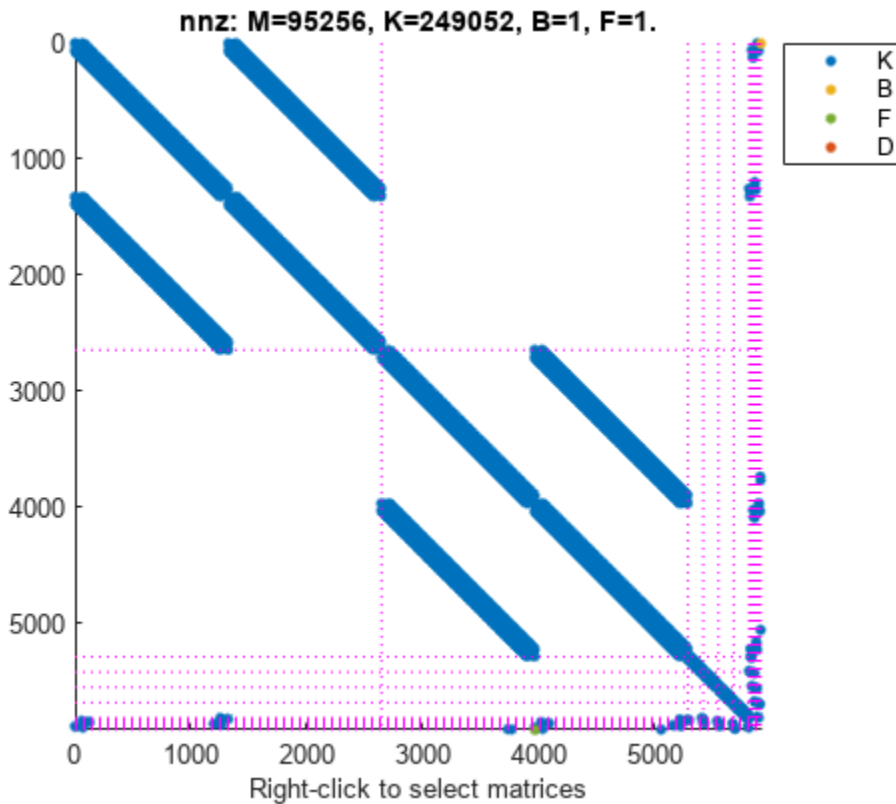

Now, specify physical connections using the primal-assembly method.

```
sys = model;
for i=3:6
    sys = interface(sys, "Plate1",dofs{1,i}, "Pillar"+i,dofs{i,1}, 'primal');
    sys = interface(sys, "Plate2",dofs{2,i}, "Pillar"+i,dofs{i,2}, 'primal');
end
sysConPrimal = interface(sys, "Plate2",dofs{2,7}, 'primal');
```

Use `showStateInfo` to confirm the physical interfaces.

```
showStateInfo(sysConPrimal)
```

The state groups are:

Type	Name	Size
Component	Plate1	2646
Component	Plate2	2640
Component	Pillar3	108
Component	Pillar4	108
Component	Pillar5	108
Component	Pillar6	108

Primal assembly eliminates half of the redundant DOFs associated with the shared set of DOFs in the global finite element mesh.

You can use `spy` to visualize the sparse matrices in the final model.

```
spy(sysConPrimal)
```

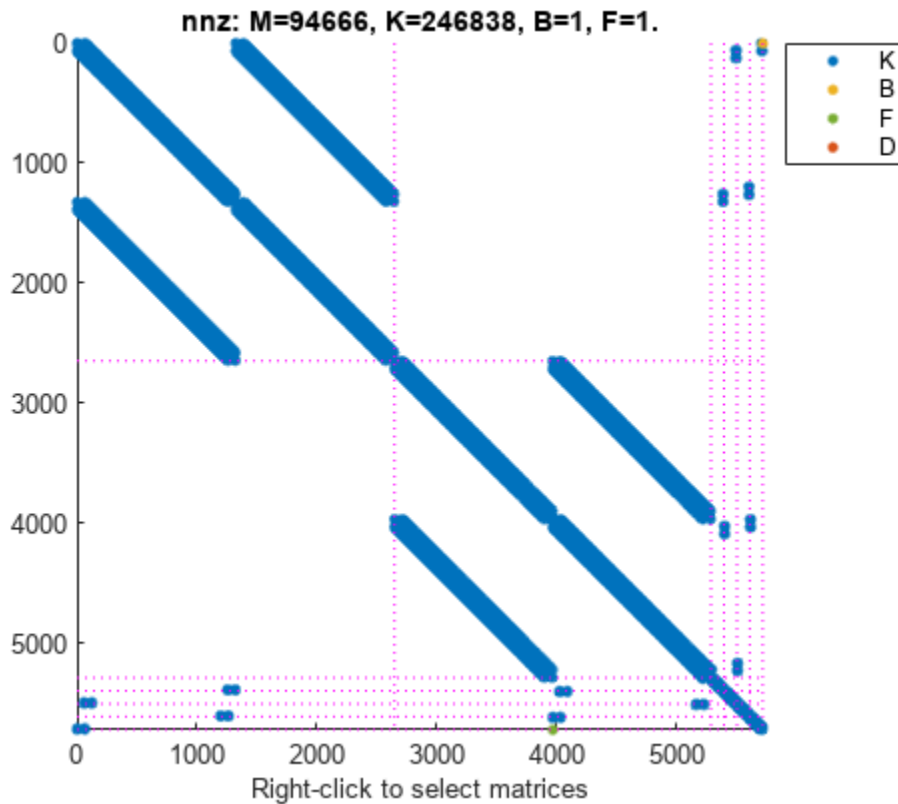

The data set for this example was provided by Victor Dolk from ASML.

Input Arguments

sys — Sparse state-space model

sparss model object | mechss model object

Sparse state-space model, specified as a sparss or mechss model object.

Output Arguments

xsys — Sparse state-space model with sorted components

sparss model object | mechss model object

Sparse state-space model with sorted components, returned as a sparss or mechss model object. In the sorted xsys, all components appear first, followed by the interfaces, and then followed by a single group of all internal signals. The matrices $sE - A$ and $M s^2 + C s + K$ have the following block arrow structure:

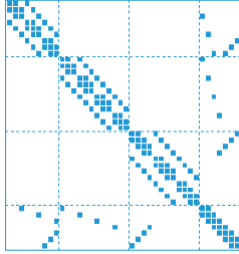

Here, each diagonal block is a sub-component of `sys`. The last row and column combines the `Interface` and `Signal` groups to capture all couplings and connections between components.

Version History

Introduced in R2020b

See Also

`spars` | `mechss` | `interface` | `showStateInfo`

Topics

“Sparse Model Basics”

“Rigid Assembly of Model Components”

zero

Zeros and gain of SISO dynamic system

Syntax

```
Z = zero(sys)
[Z,gain] = zero(sys)
[Z,gain] = zero(sys,J1,...,JN)
```

Description

`Z = zero(sys)` returns the zeros of the single-input, single-output (SISO) dynamic system model, `sys`. The output is expressed as the reciprocal of the time units specified in `sys.TimeUnit`.

`[Z,gain] = zero(sys)` also returns the zero-pole-gain of `sys`.

`[Z,gain] = zero(sys,J1,...,JN)` returns the zeros and gain of the entries in the model array `sys` with subscripts `J1,...,JN`.

Examples

Zeros of Transfer Function

Compute the zeros of the following transfer function:

$$\text{sys}(s) = \frac{4.2s^2 + 0.25s - 0.004}{s^2 + 9.6s + 17}$$

```
sys = tf([4.2,0.25,-0.004],[1,9.6,17]);
Z = zero(sys)
```

```
Z = 2×1
```

```
-0.0726
 0.0131
```

Zeros and Gain of Transfer Function

Calculate the zero locations and zero-pole gain of the following transfer function:

$$\text{sys}(s) = \frac{4.2s^2 + 0.25s - 0.004}{s^2 + 9.6s + 17}$$

```
sys = tf([4.2,0.25,-0.004],[1,9.6,17]);
[z,gain] = zero(sys)
```

```
z = 2x1
    -0.0726
     0.0131

gain = 4.2000
```

The zero locations are expressed in second^{-1} , because the time unit of the transfer function (`H.TimeUnit`) is seconds.

Zeros and Gain of Models in an Array

For this example, load a 3-by-1 array of transfer function models.

```
load('tfArray.mat','sys');
size(sys)

3x1 array of transfer functions.
Each model has 1 outputs and 1 inputs.
```

Find the zeros and gain values of the models in the array.

```
[Z, gain] = zero(sys);
Z(:,:,1,1)

ans =

    0x1 empty double column vector

gain(:,:,1,1)

ans = 1
```

`zero` returns an array each for the zeros and the gain values respectively. Here, `Z(:,:,1,1)` and `gain(:,:,1,1)` corresponds to the zero and the gain value of the first model in the array, that is, `sys(:,:,1,1)`.

Input Arguments

sys — Dynamic system

dynamic system model | model array

Dynamic system, specified as a SISO dynamic system model, or an array of SISO dynamic system models. Dynamic systems that you can use include continuous-time or discrete-time numeric LTI models such as `tf`, `zpk`, or `ss` models.

If `sys` is a generalized state-space model `genss` or an uncertain state-space model `uss`, `zero` returns the zeros of the current or nominal value of `sys`. If `sys` is an array of models, `zero` returns the zeros of the model corresponding to its subscript `J1, . . . , JN` in `sys`. For more information on model arrays, see “Model Arrays”.

J — Indices of models in array whose zeros you want to extract

positive integer

Indices of models in array whose zeros you want to extract, specified as a positive integer. You can provide as many indices as there are array dimensions in `sys`. For example, if `sys` is a 4-by-5 array of dynamic system models, the following command extracts the zeros for entry (2,3) in the array.

```
Z = zero(sys,2,3);
```

Output Arguments**Z — Zeros of the dynamic system**

column vector | array

Zeros of the dynamic system, returned as a column vector or an array. If `sys` is:

- A single model, then `Z` is a column vector of zeros of the dynamic system model `sys`
- A model array, then `Z` is an array containing the zeros of each model in `sys`

`Z` is expressed as the reciprocal of the time units specified in `sys.TimeUnit`. For example, zero is expressed in 1/minute if `sys.TimeUnit = 'minutes'`.

gain — Zero-pole-gain of the dynamic system

scalar

Zero-pole-gain of the dynamic system, returned as a scalar. In other words, `gain` is the value of `K` when the model is written in `zpk` form.

Tips

- If `sys` has internal delays, `zero` sets all internal delays to zero, creating a zero-order Padé approximation. This approximation ensures that the system has a finite number of zeros. `zero` returns an error if setting internal delays to zero creates singular algebraic loops. To assess the stability of models with internal delays, use `step` or `impulse`.
- To calculate the transmission zeros of a multi-input, multi-output (MIMO) system, use `tzero`.

Version History

Introduced before R2006a

See Also

pole | pzmap | tzero | step | impulse | pzplot

Topics

“Pole and Zero Locations”

zgrid

Generate z-plane grid of constant damping factors and natural frequencies

Syntax

```
zgrid
zgrid(T)
zgrid(zeta,wn)
zgrid(zeta,wn,T)

zgrid( ____, 'new' )
zgrid(AX, ____)
```

Description

`zgrid` generates a grid of constant damping factors from 0 to 1 in steps of 0.1 and natural frequencies from 0 to π/T in steps of $0.1*\pi/T$ for root locus and pole-zero maps. The default steps of $0.1*\pi/T$ represent fractions of the Nyquist frequencies. `zgrid` then plots the grid over the current axis. `zgrid` creates the grid over the plot without altering the current axis limits if the current axis contains a discrete z-plane root locus diagram or pole-zero map. Use this syntax to plot multiple systems with different sample times.

Alternatively, you can select **Grid** from the context menu in the plot window to generate the same z-plane grid.

`zgrid(T)` generates the z-plane grid by using default values for damping factor and natural frequency relative to the sample time T .

`zgrid(zeta,wn)` plots a grid of constant damping factor and natural frequency lines for the damping factors and normalized natural frequencies in the vectors `zeta` and `wn`, respectively. When the sample time is not specified, the frequency values in `wn` are interpreted as normalized values, that is, wn/T .

`zgrid(zeta,wn,T)` plots a grid of constant damping factor and natural frequency lines for the damping factors and natural frequencies in the vectors `zeta` and `wn`, relative to sample time T . `zeta` lines are independent for T but the `wn` lines depend on the sample time value. Use this syntax to create the z-plane grid with specific values of `wn`.

`zgrid(____, 'new')` clears the current axes first and sets `hold` on.

`zgrid(AX, ____)` plots the z-plane grid on the `Axes` or `UIAxes` object in the current figure with the handle `AX`. Use this syntax when creating apps with `zgrid` in the App Designer.

Examples

Plot z-plane Grid Lines on the Root Locus

To see the z-plane grid on the root locus plot, type

```
H = tf([2 -3.4 1.5],[1 -1.6 0.8],-1)
```

```
H =
```

$$\frac{2z^2 - 3.4z + 1.5}{z^2 - 1.6z + 0.8}$$

```
Sample time: unspecified
Discrete-time transfer function.
```

```
rlocus(H)
zgrid
axis equal
```

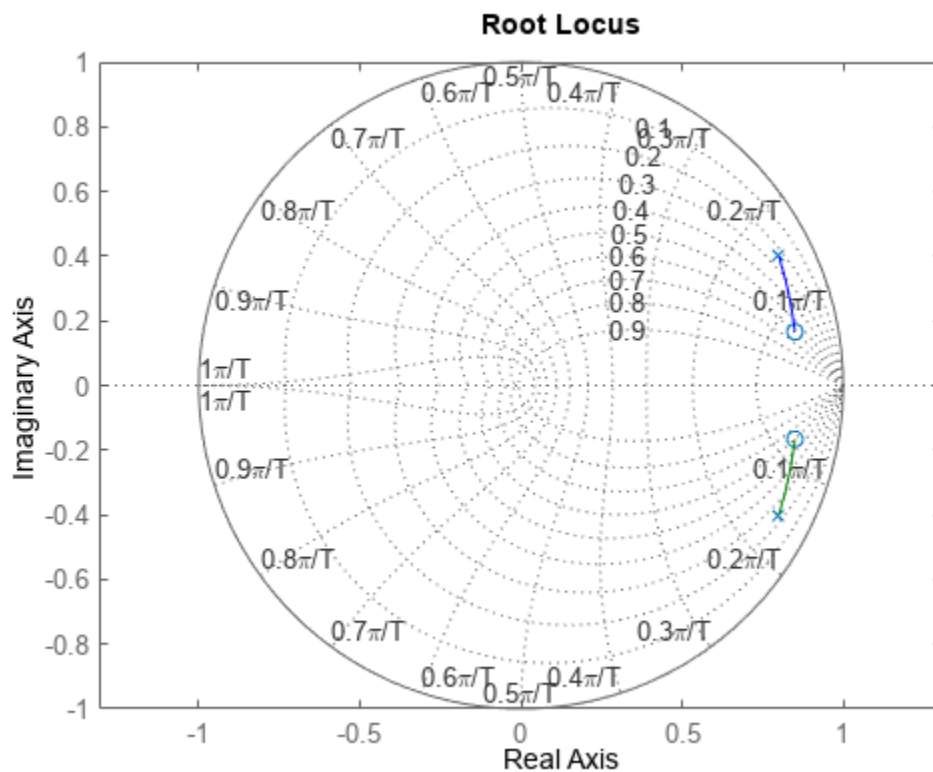

Normalized and True z-plane Grid Lines on the Pole-Zero Map

For this example, consider a discrete-time transfer function `sys` with a sample time of 0.1s. Now plot the pole-zero map of `sys` and visualize the default z-plane grid without specifying the sample time.

```
sys = tf([2 -3.4 1.5],[1 -1.6 0.8],0.1);
Ts = 0.1;
figure()
pzmap(sys)
zgrid()
axis equal
```

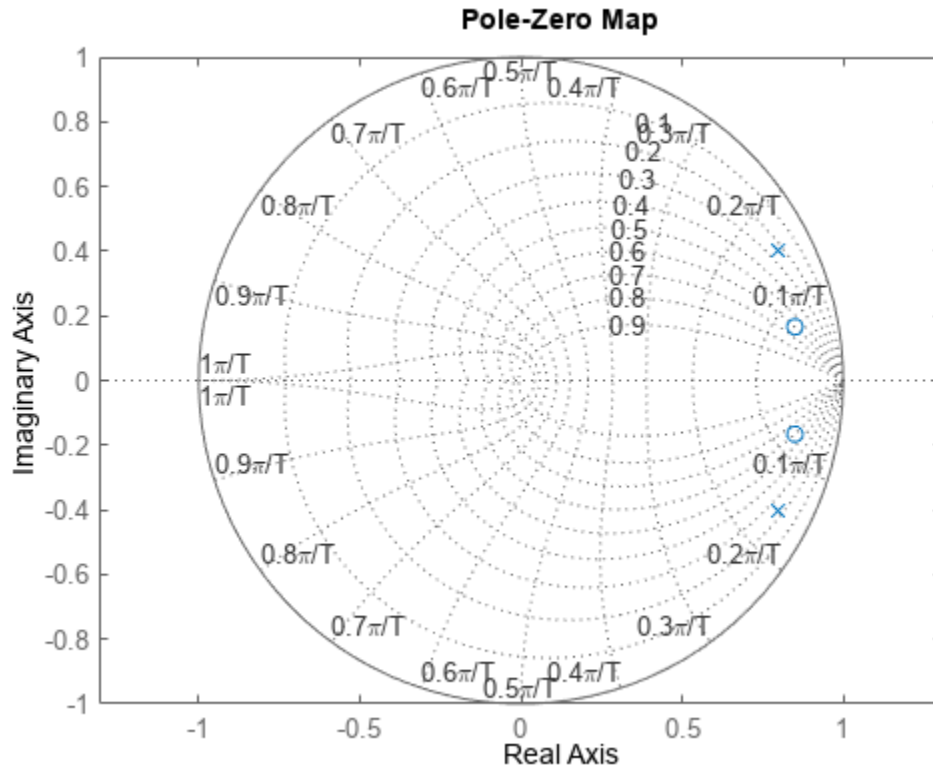

Observe that the frequencies on the z-plane grid are normalized in terms of $f\frac{\pi}{T}$. To obtain the true frequency values on the grid, specify the sample time with the `zgrid` command.

```
figure()
pzmap(sys)
zgrid(Ts)
axis equal
```

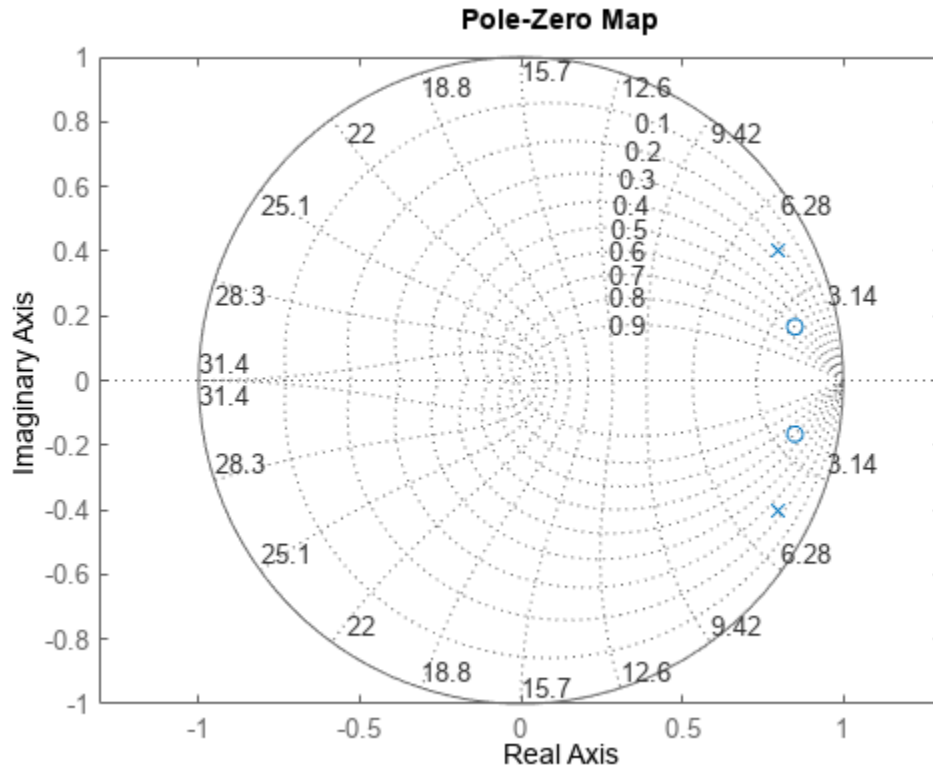

Now, observe that the frequency values on the plot are true values, that is, they are non-normalized.

Input Arguments

zeta – Damping ratio

vector

Damping ratio, specified as a vector in the same order as `wn`.

wn – Natural frequency values

vector

Natural frequency values, specified as a vector. Natural frequencies are plotted as true values when `T` is specified. When the sample time is not specified, `zgrid` normalizes the values as wn/T .

T – Sample time

positive scalar | -1

Sample time, specified as:

- A positive scalar representing the sampling period of a discrete-time system. The actual frequency values are displayed on the frequency grid.
- -1 for a discrete-time system with an unspecified sample time. The frequency values are displayed as normalized values $f \cdot \pi / T$ for the default grid.

zeta lines are independent of T while wn lines are dependent on the sample time. You must specify T to plot specific values of wn . When the sample time T is not specified, the required wn values are interpreted as normalized values, that is, wn/T .

AX — Object handle

Axes object | UIAxes object

Object handle, specified as an Axes or UIAxes object. Use AX to create apps with `zgrid` in the App Designer.

Version History

Introduced before R2006a

See Also

`pzmap` | `rlocus` | `sgrid`

zpk

Zero-pole-gain model

Description

Use `zpk` to create zero-pole-gain models, or to convert dynamic system models to zero-pole-gain form.

Zero-pole-gain models are a representation of transfer functions in factorized form. For example, consider the following continuous-time SISO transfer function:

$$G(s) = \frac{s^2 - 3s - 4}{s^2 + 5s + 6}$$

$G(s)$ can be factorized into the zero-pole-gain form as:

$$G(s) = \frac{(s + 1)(s - 4)}{(s + 2)(s + 3)}$$

A more general representation of the SISO zero-pole-gain model is as follows:

$$h(s) = k \frac{(s - z(1))(s - z(2)) \dots (s - z(m))}{(s - p(1))(s - p(2)) \dots (s - p(n))}$$

Here, z and p are the vectors of real-valued or complex-valued zeros and poles, and K is the real-valued or complex-valued scalar gain

You can create a zero-pole-gain model object either by specifying the poles, zeros and gains directly, or by converting a model of another type (such as a state-space model `ss`) to zero-pole-gain form.

You can also use `zpk` to create generalized state-space (`genss`) models or uncertain state-space (`uss`) models.

Creation

Syntax

```
sys = zpk(zeros,poles,gain)
sys = zpk(zeros,poles,gain,ts)
sys = zpk(zeros,poles,gain,ltiSys)

sys = zpk(m)

sys = zpk( ____,Name,Value)

sys = zpk(ltiSys)
sys = zpk(ltiSys,component)

s = zpk('s')
```

```
z = zpk('z',ts)
```

Description

`sys = zpk(zeros,poles,gain)` creates a continuous-time zero-pole-gain model with `zeros` and `poles` specified as vectors and the scalar value of `gain`. The output `sys` is a `zpk` model object storing the model data. Set `zeros` or `poles` to `[]` for systems without zeros or poles. These two inputs need not have equal length and the model need not be proper (that is, have an excess of poles).

`sys = zpk(zeros,poles,gain,ts)` creates a discrete-time zero-pole-gain model with sample time `ts`. Set `ts` to `-1` or `[]` to leave the sample time unspecified.

`sys = zpk(zeros,poles,gain,ltiSys)` creates a zero-pole-gain model with properties inherited from the dynamic system model `ltiSys`, including the sample time.

`sys = zpk(m)` creates a zero-pole-gain model that represents the static gain, `m`.

`sys = zpk(____,Name,Value)` sets “Properties” on page 2-1546 of the zero-pole-gain model using one or more name-value pair arguments for any of the previous input-argument combinations.

`sys = zpk(ltiSys)` converts the dynamic system model `ltiSys` to a zero-pole-gain model.

`sys = zpk(ltiSys,component)` converts the specified component of `ltiSys` to zero-pole-gain model form. Use this syntax only when `ltiSys` is an identified linear time-invariant (LTI) model such as an `idss` or an `idtf` model.

`s = zpk('s')` creates a special variable `s` that you can use in a rational expression to create a continuous-time zero-pole-gain model. Using a rational expression can sometimes be easier and more intuitive than specifying polynomial coefficients.

`z = zpk('z',ts)` creates special variable `z` that you can use in a rational expression to create a discrete-time zero-pole-gain model. To leave the sample time unspecified, set `ts` input argument to `-1`.

Input Arguments

zeros — Zeros of the zero-pole-gain model

row vector | Ny-by-Nu cell array of row vectors

Zeros of the zero-pole-gain model, specified as:

- A row vector for SISO models. For instance, use `[1,2+i,2-1]` to create a model with zeros at $s = 1$, $s = 2+i$, and $s = 2-i$. For an example, see “Continuous-Time SISO Zero-Pole-Gain Model” on page 2-1554.
- An Ny-by-Nu cell array of row vectors to specify a MIMO zero-pole-gain model, where Ny is the number of outputs, and Nu is the number of inputs. For an example, see “Discrete-Time MIMO Zero-Pole-Gain Model” on page 2-1555.

For instance, if `a` is `realp` tunable parameter with nominal value 3, then you can use `zeros = [1 2 a]` to create a `genss` model with zeros at $s = 1$ and $s = 2$ and a tunable zero at $s = 3$.

Also a property of the `zpk` object. This input argument sets the initial value of property `Z`.

poles — Poles of the zero-pole-gain model

row vector | Ny-by-Nu cell array of row vectors

Poles of the zero-pole-gain model, specified as:

- A row vector for SISO models. For an example, see “Continuous-Time SISO Zero-Pole-Gain Model” on page 2-1554.
- An Ny-by-Nu cell array of row vectors to specify a MIMO zero-pole-gain model, where Ny is the number of outputs and Nu is the number of inputs. For an example, see “Discrete-Time MIMO Zero-Pole-Gain Model” on page 2-1555.

Also a property of the zpk object. This input argument sets the initial value of property P.

gain — Gain of the zero-pole-gain model

scalar | Ny-by-Nu cell array of row vectors

Gain of the zero-pole-gain model, specified as:

- A scalar for SISO models. For an example, see “Continuous-Time SISO Zero-Pole-Gain Model” on page 2-1554.
- An Ny-by-Nu matrix to specify a MIMO zero-pole-gain model, where Ny is the number of outputs and Nu is the number of inputs. For an example, see “Discrete-Time MIMO Zero-Pole-Gain Model” on page 2-1555.

Also a property of the zpk object. This input argument sets the initial value of property K.

ts — Sample time

scalar

Sample time, specified as a scalar. Also a property of the zpk object. This input argument sets the initial value of property Ts.

ltiSys — Dynamic system

dynamic system model | model array

Dynamic system, specified as a SISO or MIMO dynamic system model or array of dynamic system models. Dynamic systems that you can use include:

- Continuous-time or discrete-time numeric LTI models, such as `tf`, `zpk`, `ss`, or `pid` models.
- Generalized or uncertain LTI models such as `genss` or `uss` models. (Using uncertain models requires a Robust Control Toolbox license.)

The resulting zero-pole-gain model assumes

- current values of the tunable components for tunable control design blocks.
- nominal model values for uncertain control design blocks.
- Identified LTI models, such as `idtf`, `idss`, `idproc`, `idpoly`, and `idgrey` models. To select the component of the identified model to convert, specify `component`. If you do not specify `component`, `tf` converts the measured component of the identified model by default. (Using identified models requires System Identification Toolbox software.)

An identified nonlinear model cannot be converted into a zpk model object. You may first use linear approximation functions such as `linearize` and `linapp` (This functionality requires System Identification Toolbox software.)

m — Static gain

scalar | matrix

Static gain, specified as a scalar or matrix. Static gain or steady state gain of a system represents the ratio of the output to the input under steady state condition.

component — Component of identified model

'measured' (default) | 'noise' | 'augmented'

Component of identified model to convert, specified as one of the following:

- 'measured' — Convert the measured component of `sys`.
- 'noise' — Convert the noise component of `sys`
- 'augmented' — Convert both the measured and noise components of `sys`.

`component` only applies when `sys` is an identified LTI model.

For more information on identified LTI models and their measured and noise components, see “Identified LTI Models”.

Output Arguments**sys — Output system model**

zpk model object | genss model object | uss model object

Output system model, returned as:

- A zero-pole-gain (zpk) model object, when the `zeros`, `poles` and `gain` input arguments contain numeric values.
- A generalized state-space model (genss) object, when the `zeros`, `poles` and `gain` input arguments includes tunable parameters, such as `realp` parameters or generalized matrices (`genmat`).
- An uncertain state-space model (uss) object, when the `zeros`, `poles` and `gain` input arguments includes uncertain parameters. Using uncertain models requires a Robust Control Toolbox license.

Properties**Z — System zeros**

cell array | Ny-by-Nu cell array of row vectors

System zeros, specified as:

- A cell array of transfer function zeros or the numerator roots for SISO models.
- An Ny-by-Nu cell array of row vectors of the zeros for each I/O pair in a MIMO model, where Ny is the number of outputs and Nu is the number of inputs.

The values of Z can be either real-valued or complex-valued.

P — System poles

cell array | Ny-by-Nu cell array of row vectors

System poles, specified as:

- A cell array of transfer function poles or the denominator roots for SISO models.
- An N_y -by- N_u cell array of row vectors of the poles for each I/O pair in a MIMO model, where N_y is the number of outputs and N_u is the number of inputs.

The values of P can be either real-valued or complex-valued.

K — System gains

scalar | N_y -by- N_u matrix

System gains, specified as:

- A scalar value for SISO models.
- An N_y -by- N_u matrix storing the gain values for each I/O pair of the MIMO model, where N_y is the number of outputs and N_u is the number of inputs.

The values of K can be either real-valued or complex-valued.

DisplayFormat — Specifies how the numerator and denominator polynomials are factorized for display

'roots' (default) | 'frequency' | 'time constant'

Specifies how the numerator and denominator polynomials are factorized for display, specified as one of the following:

- 'roots' — Display factors in terms of the location of the polynomial roots. 'roots' is the default value of `DisplayFormat`
- 'frequency' — Display factors in terms of root natural frequencies ω_0 and damping ratios ζ .

The 'frequency' display format is not available for discrete-time models with `Variable` value 'z^-1' or 'q^-1'.

- 'time constant' — Display factors in terms of root time constants τ and damping ratios ζ .

The 'time constant' display format is not available for discrete-time models with `Variable` value 'z^-1' or 'q^-1'.

For continuous-time models, the following table shows how the polynomial factors are arranged in each display format.

DisplayName Value	First-Order Factor (Real Root R)	Second-Order Factor (Complex Root pair $R = a \pm jb$)
'roots'	$(s - R)$	$(s^2 - \alpha s + \beta)$, where $\alpha = 2a$, $\beta = a^2 + b^2$
'frequency'	$\left(1 - \frac{s}{\omega_0}\right)$, where $\omega_0 = R$	$1 - 2\zeta\left(\frac{s}{\omega_0}\right) + \left(\frac{s}{\omega_0}\right)^2$, where $\omega_0^2 = a^2 + b^2$, $\zeta = \frac{a}{\omega_0}$
'time constant'	$(1 - \tau s)$, where $\tau = \frac{1}{R}$	$1 - 2\zeta(\tau s) + (\tau s)^2$, where $\tau = \frac{1}{\omega_0}$, $\zeta = a\tau$

For discrete-time models, the polynomial factors are arranged similar to the continuous-time models, with the following variable substitutions:

$$s \rightarrow w = \frac{z-1}{T_s}; \quad R \rightarrow \frac{R-1}{T_s},$$

where T_s is the sample time. In discrete-time, τ and ω_0 closely match the time constant and natural frequency of the equivalent continuous-time root, provided that the following condition is fulfilled:

$$|z-1| < < T_s \left(\omega_0 < < \frac{\pi}{T_s} = \text{Nyquist frequency} \right).$$

Variable — Zero-pole-gain model display variable

's' (default) | 'z' | 'p' | 'q' | 'z^-1' | 'q^-1'

Zero-pole-gain model display variable, specified as one of the following:

- 's' — Default for continuous-time models
- 'z' — Default for discrete-time models
- 'p' — Equivalent to 's'
- 'q' — Equivalent to 'z'
- 'z^-1' — Inverse of 'z'
- 'q^-1' — Equivalent to 'z^-1'

IODelay — Transport delay

0 (default) | scalar | Ny-by-Nu array

Transport delay, specified as one of the following:

- Scalar — Specify the transport delay for a SISO system or the same transport delay for all input/output pairs of a MIMO system.
- Ny-by-Nu array — Specify separate transport delays for each input/output pair of a MIMO system. Here, Ny is the number of outputs and Nu is the number of inputs.

For continuous-time systems, specify transport delays in the time unit specified by the `TimeUnit` property. For discrete-time systems, specify transport delays in integer multiples of the sample time, T_s . For more information on time delay, see “Time Delays in Linear Systems”.

InputDelay — Input delay

0 (default) | scalar | Nu-by-1 vector

Input delay for each input channel, specified as one of the following:

- Scalar — Specify the input delay for a SISO system or the same delay for all inputs of a multi-input system.
- Nu-by-1 vector — Specify separate input delays for input of a multi-input system, where Nu is the number of inputs.

For continuous-time systems, specify input delays in the time unit specified by the `TimeUnit` property. For discrete-time systems, specify input delays in integer multiples of the sample time, T_s .

For more information, see “Time Delays in Linear Systems”.

OutputDelay — Output delay 0 (default) | scalar | Ny-by-1 vector

Output delay for each output channel, specified as one of the following:

- Scalar — Specify the output delay for a SISO system or the same delay for all outputs of a multi-output system.
- Ny-by-1 vector — Specify separate output delays for output of a multi-output system, where Ny is the number of outputs.

For continuous-time systems, specify output delays in the time unit specified by the `TimeUnit` property. For discrete-time systems, specify output delays in integer multiples of the sample time, `Ts`.

For more information, see “Time Delays in Linear Systems”.

Ts — Sample time 0 (default) | positive scalar | -1

Sample time, specified as:

- 0 for continuous-time systems.
- A positive scalar representing the sampling period of a discrete-time system. Specify `Ts` in the time unit specified by the `TimeUnit` property.
- -1 for a discrete-time system with an unspecified sample time.

Note Changing `Ts` does not discretize or resample the model. To convert between continuous-time and discrete-time representations, use `c2d` and `d2c`. To change the sample time of a discrete-time system, use `d2d`.

TimeUnit — Time variable units

'seconds' (default) | 'nanoseconds' | 'microseconds' | 'milliseconds' | 'minutes' | 'hours' | 'days' | 'weeks' | 'months' | 'years' | ...

Time variable units, specified as one of the following:

- 'nanoseconds'
- 'microseconds'
- 'milliseconds'
- 'seconds'
- 'minutes'
- 'hours'
- 'days'
- 'weeks'
- 'months'
- 'years'

Changing `TimeUnit` has no effect on other properties, but changes the overall system behavior. Use `chgTimeUnit` to convert between time units without modifying system behavior.

InputName — Input channel names`''` (default) | character vector | cell array of character vectors

Input channel names, specified as one of the following:

- A character vector, for single-input models.
- A cell array of character vectors, for multi-input models.
- `''`, no names specified, for any input channels.

Alternatively, you can assign input names for multi-input models using automatic vector expansion. For example, if `sys` is a two-input model, enter the following:

```
sys.InputName = 'controls';
```

The input names automatically expand to `{'controls(1)'; 'controls(2)'}`.

You can use the shorthand notation `u` to refer to the `InputName` property. For example, `sys.u` is equivalent to `sys.InputName`.

Use `InputName` to:

- Identify channels on model display and plots.
- Extract subsystems of MIMO systems.
- Specify connection points when interconnecting models.

InputUnit — Input channel units`''` (default) | character vector | cell array of character vectors

Input channel units, specified as one of the following:

- A character vector, for single-input models.
- A cell array of character vectors, for multi-input models.
- `''`, no units specified, for any input channels.

Use `InputUnit` to specify input signal units. `InputUnit` has no effect on system behavior.

InputGroup — Input channel groups

structure

Input channel groups, specified as a structure. Use `InputGroup` to assign the input channels of MIMO systems into groups and refer to each group by name. The field names of `InputGroup` are the group names and the field values are the input channels of each group. For example, enter the following to create input groups named `controls` and `noise` that include input channels 1 and 2, and 3 and 5, respectively.

```
sys.InputGroup.controls = [1 2];  
sys.InputGroup.noise = [3 5];
```

You can then extract the subsystem from the `controls` inputs to all outputs using the following.

```
sys(:, 'controls')
```

By default, `InputGroup` is a structure with no fields.

OutputName — Output channel names

' ' (default) | character vector | cell array of character vectors

Output channel names, specified as one of the following:

- A character vector, for single-output models.
- A cell array of character vectors, for multi-output models.
- ' ', no names specified, for any output channels.

Alternatively, you can assign output names for multi-output models using automatic vector expansion. For example, if `sys` is a two-output model, enter the following.

```
sys.OutputName = 'measurements';
```

The output names automatically expand to `{'measurements(1)'; 'measurements(2)'}`.

You can also use the shorthand notation `y` to refer to the `OutputName` property. For example, `sys.y` is equivalent to `sys.OutputName`.

Use `OutputName` to:

- Identify channels on model display and plots.
- Extract subsystems of MIMO systems.
- Specify connection points when interconnecting models.

OutputUnit — Output channel units

' ' (default) | character vector | cell array of character vectors

Output channel units, specified as one of the following:

- A character vector, for single-output models.
- A cell array of character vectors, for multi-output models.
- ' ', no units specified, for any output channels.

Use `OutputUnit` to specify output signal units. `OutputUnit` has no effect on system behavior.

OutputGroup — Output channel groups

structure

Output channel groups, specified as a structure. Use `OutputGroup` to assign the output channels of MIMO systems into groups and refer to each group by name. The field names of `OutputGroup` are the group names and the field values are the output channels of each group. For example, create output groups named `temperature` and `measurement` that include output channels 1, and 3 and 5, respectively.

```
sys.OutputGroup.temperature = [1];
sys.OutputGroup.measurement = [3 5];
```

You can then extract the subsystem from all inputs to the `measurement` outputs using the following.

```
sys('measurement', :)
```

By default, `OutputGroup` is a structure with no fields.

Name — System name

'' (default) | character vector

System name, specified as a character vector. For example, 'system_1'.

Notes — User-specified text

{ } (default) | character vector | cell array of character vectors

User-specified text that you want to associate with the system, specified as a character vector or cell array of character vectors. For example, 'System is MIMO'.

UserData — User-specified data

[] (default) | any MATLAB data type

User-specified data that you want to associate with the system, specified as any MATLAB data type.

SamplingGrid — Sampling grid for model arrays

structure array

Sampling grid for model arrays, specified as a structure array.

Use `SamplingGrid` to track the variable values associated with each model in a model array, including identified linear time-invariant (IDLTI) model arrays.

Set the field names of the structure to the names of the sampling variables. Set the field values to the sampled variable values associated with each model in the array. All sampling variables must be numeric scalars, and all arrays of sampled values must match the dimensions of the model array.

For example, you can create an 11-by-1 array of linear models, `sysarr`, by taking snapshots of a linear time-varying system at times `t = 0:10`. The following code stores the time samples with the linear models.

```
sysarr.SamplingGrid = struct('time',0:10)
```

Similarly, you can create a 6-by-9 model array, `M`, by independently sampling two variables, `zeta` and `w`. The following code maps the (`zeta,w`) values to `M`.

```
[zeta,w] = ndgrid(<6 values of zeta>,<9 values of w>)
M.SamplingGrid = struct('zeta',zeta,'w',w)
```

When you display `M`, each entry in the array includes the corresponding `zeta` and `w` values.

`M`

```
M(:,:,1,1) [zeta=0.3, w=5] =
```

```

      25
-----
s^2 + 3 s + 25
```

```
M(:,:,2,1) [zeta=0.35, w=5] =
```

```

      25
-----
s^2 + 3.5 s + 25
```

...

For model arrays generated by linearizing a Simulink model at multiple parameter values or operating points, the software populates `SamplingGrid` automatically with the variable values that correspond to each entry in the array. For instance, the Simulink Control Design commands `linearize` and `sLinearizer` populate `SamplingGrid` automatically.

By default, `SamplingGrid` is a structure with no fields.

Object Functions

The following lists contain a representative subset of the functions you can use with `zpk` models. In general, any function applicable to “Dynamic System Models” is applicable to a `zpk` object.

Linear Analysis

<code>step</code>	Step response plot of dynamic system; step response data
<code>impulse</code>	Impulse response plot of dynamic system; impulse response data
<code>lsim</code>	Plot simulated time response of dynamic system to arbitrary inputs; simulated response data
<code>bode</code>	Bode plot of frequency response, or magnitude and phase data
<code>nyquist</code>	Nyquist plot of frequency response
<code>nichols</code>	Nichols chart of frequency response
<code>bandwidth</code>	Frequency response bandwidth

Stability Analysis

<code>pole</code>	Poles of dynamic system
<code>zero</code>	Zeros and gain of SISO dynamic system
<code>pzplot</code>	Pole-zero plot of dynamic system model with additional plot customization options
<code>margin</code>	Gain margin, phase margin, and crossover frequencies

Model Transformation

<code>tf</code>	Transfer function model
<code>ss</code>	State-space model
<code>c2d</code>	Convert model from continuous to discrete time
<code>d2c</code>	Convert model from discrete to continuous time
<code>d2d</code>	Resample discrete-time model

Model Interconnection

<code>feedback</code>	Feedback connection of multiple models
<code>connect</code>	Block diagram interconnections of dynamic systems
<code>series</code>	Series connection of two models
<code>parallel</code>	Parallel connection of two models

Controller Design

<code>pidtune</code>	PID tuning algorithm for linear plant model
<code>rlocus</code>	Root locus plot of dynamic system
<code>lqr</code>	Linear-Quadratic Regulator (LQR) design
<code>lqg</code>	Linear-Quadratic-Gaussian (LQG) design

lqi Linear-Quadratic-Integral control
kalman Design Kalman filter for state estimation

Examples

Continuous-Time SISO Zero-Pole-Gain Model

For this example, consider the following continuous-time SISO zero-pole-gain model:

$$\text{sys}(s) = \frac{-2s}{(s-1-i)(s-1+i)(s-2)}$$

Specify the zeros, poles and gain, and create the SISO zero-pole-gain model.

```
zeros = 0;
poles = [1-1i 1+1i 2];
gain = -2;
sys = zpk(zeros,poles,gain)
```

```
sys =
```

$$\frac{-2 s}{(s-2) (s^2 - 2s + 2)}$$

Continuous-time zero/pole/gain model.

Discrete-Time SISO Zero-Pole-Gain Model

For this example, consider the following SISO discrete-time zero-pole-gain model with 0.1s sample time:

$$\text{sys}(s) = \frac{7(z-1)(z-2)(z-3)}{(z-6)(z-5)(z-4)}$$

Specify the zeros, poles, gains and the sample time, and create the discrete-time SISO zero-pole-gain model.

```
zeros = [1 2 3];
poles = [6 5 4];
gain = 7;
ts = 0.1;
sys = zpk(zeros,poles,gain,ts)
```

```
sys =
```

$$\frac{7 (z-1) (z-2) (z-3)}{(z-6) (z-5) (z-4)}$$

Sample time: 0.1 seconds
Discrete-time zero/pole/gain model.

Concatenate SISO Zero-Pole-Gain models into a MIMO Zero-Pole-Gain Model

In this example, you create a MIMO zero-pole-gain model by concatenating SISO zero-pole-gain models. Consider the following single-input, two-output continuous-time zero-pole-gain model:

$$\text{sys}(s) = \begin{bmatrix} \frac{(s-1)}{(s+1)} \\ \frac{(s+2)}{(s+2+i)(s+2-i)} \end{bmatrix}.$$

Specify the MIMO zero-pole-gain model by concatenating the SISO entries.

```
zeros1 = 1;
poles1 = -1;
gain = 1;
sys1 = zpk(zeros1,poles1,gain)
```

sys1 =

```
(s-1)
-----
(s+1)
```

Continuous-time zero/pole/gain model.

```
zeros2 = -2;
poles2 = [-2+1i -2-1i];
sys2 = zpk(zeros2,poles2,gain)
```

sys2 =

```
(s+2)
-----
(s^2 + 4s + 5)
```

Continuous-time zero/pole/gain model.

```
sys = [sys1;sys2]
```

sys =

From input to output...

```
(s-1)
1:  ----
   (s+1)
```

```
(s+2)
2:  -----
   (s^2 + 4s + 5)
```

Continuous-time zero/pole/gain model.

Discrete-Time MIMO Zero-Pole-Gain Model

Create a zero-pole-gain model for the discrete-time, multi-input, multi-output model:

$$\text{sys}(z) = \begin{bmatrix} \frac{1}{(z+0.3)} & \frac{z}{(z+0.3)} \\ \frac{-(z-2)}{(z+0.3)} & \frac{3}{(z+0.3)} \end{bmatrix}$$

with sample time $t_s = 0.2$ seconds.

Specify the zeros and poles as cell arrays and the gains as an array.

```
zeros = {[ ] 0; 2 [ ]};
poles = {-0.3 -0.3; -0.3 -0.3};
gain = [1 1; -1 3];
ts = 0.2;
```

Create the discrete-time MIMO zero-pole-gain model.

```
sys = zpke(zeros,poles,gain,ts)
```

```
sys =
```

```
From input 1 to output...
```

```
      1
1:  -----
    (z+0.3)
```

```
      - (z-2)
2:  -----
    (z+0.3)
```

```
From input 2 to output...
```

```
      z
1:  -----
    (z+0.3)
```

```
      3
2:  -----
    (z+0.3)
```

```
Sample time: 0.2 seconds
```

```
Discrete-time zero/pole/gain model.
```

Specify Input Names for Zero-Pole-Gain Model

Specify the zeros, poles and gain along with the sample time and create the zero-pole-gain model, specifying the state and input names using name-value pairs.

```
zeros = 4;
poles = [-1+2i -1-2i];
gain = 3;
ts = 0.05;
sys = zpke(zeros,poles,gain,ts, 'InputName', 'Force')
```

```

sys =

  From input "Force" to output:
    3 (z-4)
  -----
    (z^2 + 2z + 5)

Sample time: 0.05 seconds
Discrete-time zero/pole/gain model.

```

The number of input names must be consistent with the number of zeros.

Naming the inputs and outputs can be useful when dealing with response plots for MIMO systems.

```
step(sys)
```

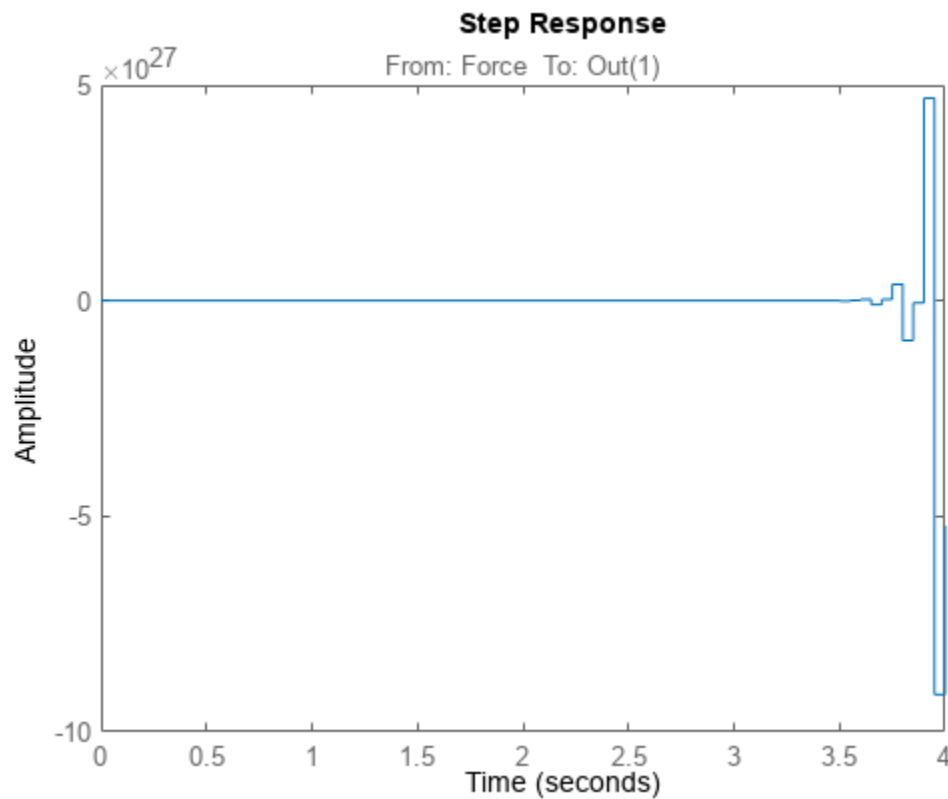

Notice the input name Force in the title of the step response plot.

Continuous-Time Zero-Pole-Gain Model Using Rational Expression

For this example, create a continuous-time zero-pole-gain model using rational expressions. Using a rational expression can sometimes be easier and more intuitive than specifying poles and zeros.

Consider the following system:

$$\text{sys}(s) = \frac{s}{s^2 + 2s + 10}.$$

To create the transfer function model, first specify `s` as a zpk object.

```
s = zpk('s')
```

```
s =
```

```
    s
```

Continuous-time zero/pole/gain model.

Create the zero-pole-gain model using `s` in the rational expression.

```
sys = s/(s^2 + 2*s + 10)
```

```
sys =
```

```
      s
-----
(s^2 + 2s + 10)
```

Continuous-time zero/pole/gain model.

Discrete-Time Zero-Pole-Gain Model Using Rational Expression

For this example, create a discrete-time zero-pole-gain model using a rational expression. Using a rational expression can sometimes be easier and more intuitive than specifying poles and zeros.

Consider the following system:

$$\text{sys}(z) = \frac{z - 1}{z^2 - 1.85z + 0.9}.$$

To create the zero-pole-gain model, first specify `z` as a zpk object and the sample time `ts`.

```
ts = 0.1;
```

```
z = zpk('z',ts)
```

```
z =
```

```
    z
```

Sample time: 0.1 seconds

Discrete-time zero/pole/gain model.

Create the zero-pole-gain model using `z` in the rational expression.

```
sys = (z - 1) / (z^2 - 1.85*z + 0.9)
```

```
sys =
```

```
      (z-1)
-----
```

$$(z^2 - 1.85z + 0.9)$$

Sample time: 0.1 seconds
Discrete-time zero/pole/gain model.

Zero-Pole-Gain Model with Inherited Properties

For this example, create a zero-pole-gain model with properties inherited from another zero-pole-gain model. Consider the following two zero-pole-gain models:

$$\text{sys1}(s) = \frac{2s}{s(s+8)} \quad \text{and} \quad \text{sys2}(s) = \frac{0.8(s-1)}{(s+3)(s-5)}.$$

For this example, create `sys1` with the `TimeUnit` and `InputDelay` property set to 'minutes'.

```
zero1 = 0;
pole1 = [0;-8];
gain1 = 2;
sys1 = zpk(zero1,pole1,gain1,'TimeUnit','minutes','InputUnit','minutes')
```

`sys1 =`

$$\frac{2 s}{s (s+8)}$$

Continuous-time zero/pole/gain model.

```
propValues1 = [sys1.TimeUnit,sys1.InputUnit]
```

```
propValues1 = 1x2 cell
    {'minutes'}    {'minutes'}
```

Create the second zero-pole-gain model with properties inherited from `sys1`.

```
zero = 1;
pole = [-3,5];
gain2 = 0.8;
sys2 = zpk(zero,pole,gain2,sys1)
```

`sys2 =`

$$\frac{0.8 (s-1)}{(s+3) (s-5)}$$

Continuous-time zero/pole/gain model.

```
propValues2 = [sys2.TimeUnit,sys2.InputUnit]
```

```
propValues2 = 1x2 cell
    {'minutes'}    {'minutes'}
```

Observe that the zero-pole-gain model `sys2` has that same properties as `sys1`.

Static Gain MIMO Zero-Pole-Gain Model

Consider the following two-input, two-output static gain matrix m :

$$m = \begin{bmatrix} 2 & 4 \\ 3 & 5 \end{bmatrix}$$

Specify the gain matrix and create the static gain zero-pole-gain model.

```
m = [2,4;...
     3,5];
sys1 = zpk(m)
```

```
sys1 =
```

```
From input 1 to output...
```

```
1: 2
```

```
2: 3
```

```
From input 2 to output...
```

```
1: 4
```

```
2: 5
```

```
Static gain.
```

You can use static gain zero-pole-gain model `sys1` obtained above to cascade it with another zero-pole-gain model.

```
sys2 = zpk(0,[-1 7],1)
```

```
sys2 =
```

```
      s
-----
(s+1) (s-7)
```

```
Continuous-time zero/pole/gain model.
```

```
sys = series(sys1,sys2)
```

```
sys =
```

```
From input 1 to output...
```

```
2 s
```

```
1: -----
   (s+1) (s-7)
```

```
3 s
```

```
2: -----
   (s+1) (s-7)
```

```
From input 2 to output...
```

```
4 s
```

```
1: -----
   (s+1) (s-7)
```

```
2:      5 s
   -----
   (s+1) (s-7)
```

Continuous-time zero/pole/gain model.

Convert State-Space Model to Zero-Pole-Gain Model

For this example, compute the zero-pole-gain model of the following state-space model:

$$A = \begin{bmatrix} -2 & -1 \\ 1 & -2 \end{bmatrix}, \quad B = \begin{bmatrix} 1 & 1 \\ 2 & -1 \end{bmatrix}, \quad C = [1 \ 0], \quad D = [0 \ 1].$$

Create the state-space model using the state-space matrices.

```
A = [-2 -1;1 -2];
B = [1 1;2 -1];
C = [1 0];
D = [0 1];
ltiSys = ss(A,B,C,D);
```

Convert the state-space model `ltiSys` to a zero-pole-gain model.

```
sys = zpk(ltiSys)
```

```
sys =
```

```
From input 1 to output:
      s
```

```
-----
(s^2 + 4s + 5)
```

```
From input 2 to output:
```

```
(s^2 + 5s + 8)
```

```
-----
(s^2 + 4s + 5)
```

Continuous-time zero/pole/gain model.

Array of Zero-Pole-Gain Models

You can use a `for` loop to specify an array of zero-pole-gain models.

First, pre-allocate the zero-pole-gain model array with zeros.

```
sys = zpk(zeros(1,1,3));
```

The first two indices represent the number of outputs and inputs for the models, while the third index is the number of models in the array.

Create the zero-pole-gain model array using a rational expression in the for loop.

```
s = zpk('s');
for k = 1:3
    sys(:,:,k) = k/(s^2+s+k);
end
sys
```

```
sys(:,:,1,1) =
```

$$\frac{1}{(s^2 + s + 1)}$$

```
sys(:,:,2,1) =
```

$$\frac{2}{(s^2 + s + 2)}$$

```
sys(:,:,3,1) =
```

$$\frac{3}{(s^2 + s + 3)}$$

3x1 array of continuous-time zero/pole/gain models.

Extract Zero-Pole-Gain Models from Identified Model

For this example, extract the measured and noise components of an identified polynomial model into two separate zero-pole-gain models.

Load the Box-Jenkins polynomial model `ltiSys` in `identifiedModel.mat`.

```
load('identifiedModel.mat','ltiSys');
```

`ltiSys` is an identified discrete-time model of the form: $y(t) = \frac{B}{F}u(t) + \frac{C}{D}e(t)$, where $\frac{B}{F}$ represents the measured component and $\frac{C}{D}$ the noise component.

Extract the measured and noise components as zero-pole-gain models.

```
sysMeas = zpk(ltiSys,'measured')
```

```
sysMeas =
```

```
From input "u1" to output "y1":
      -0.14256 z^-1 (1-1.374z^-1)
z^(-2) * -----
      (1-0.8789z^-1) (1-0.6958z^-1)
```

Sample time: 0.04 seconds
Discrete-time zero/pole/gain model.

```
sysNoise = zpk(ltiSys,'noise')
```

```
sysNoise =
```

```
From input "v@y1" to output "y1":
      0.045563 (1+0.7245z^-1)
-----
(1-0.9658z^-1) (1 - 0.0602z^-1 + 0.2018z^-2)
```

Input groups:

Name	Channels
Noise	1

Sample time: 0.04 seconds
Discrete-time zero/pole/gain model.

The measured component can serve as a plant model, while the noise component can be used as a disturbance model for control system design.

Zero-Pole-Gain Model with Input and Output Delay

For this example, create a SISO zero-pole-gain model with an input delay of 0.5 seconds and an output delay of 2.5 seconds.

```
zeros = 5;
poles = [7+1i 7-1i -3];
gains = 1;
sys = zpk(zeros,poles,gains,'InputDelay',0.5,'OutputDelay',2.5)
```

```
sys =
```

```
exp(-3*s) * (s-5)
            -----
            (s+3) (s^2 - 14s + 50)
```

Continuous-time zero/pole/gain model.

You can also use the `get` command to display all the properties of a MATLAB object.

```
get(sys)
```

```
      Z: {[5]}
      P: {[3x1 double]}
      K: 1
DisplayFormat: 'roots'
Variable: 's'
IODElay: 0
InputDelay: 0.5000
OutputDelay: 2.5000
InputName: {''}
InputUnit: {''}
InputGroup: [1x1 struct]
OutputName: {''}
```

```

OutputUnit: {''}
OutputGroup: [1x1 struct]
Notes: [0x1 string]
UserData: []
Name: ''
Ts: 0
TimeUnit: 'seconds'
SamplingGrid: [1x1 struct]

```

For more information on specifying time delay for an LTI model, see “Specifying Time Delays”.

Control Design using Zero-Pole-Gain Models

For this example, design a 2-DOF PID controller with a target bandwidth of 0.75 rad/s for a system represented by the following zero-pole-gain model:

$$\text{sys}(s) = \frac{1}{s^2 + 0.5s + 0.1}$$

Create a zero-pole-gain model object `sys` using the `zpk` command.

```

zeros = [];
poles = [-0.25+0.2i; -0.25-0.2i];
gain = 1;
sys = zpk(zeros,poles,gain)

```

```
sys =
```

```

          1
-----
(s^2 + 0.5s + 0.1025)

```

Continuous-time zero/pole/gain model.

Using the target bandwidth, use `pidtune` to generate a 2-DOF controller.

```

wc = 0.75;
C2 = pidtune(sys, 'PID2',wc)

```

```
C2 =
```

$$u = K_p (b*r-y) + K_i \frac{1}{s} (r-y) + K_d*s (c*r-y)$$

with $K_p = 0.512$, $K_i = 0.0975$, $K_d = 0.574$, $b = 0.38$, $c = 0$

Continuous-time 2-DOF PID controller in parallel form.

Using the type 'PID2' causes `pidtune` to generate a 2-DOF controller, represented as a `pid2` object. The display confirms this result. The display also shows that `pidtune` tunes all controller coefficients, including the setpoint weights `b` and `c`, to balance performance and robustness.

For interactive PID tuning in the Live Editor, see the Tune PID Controller Live Editor task. This task lets you interactively design a PID controller and automatically generates MATLAB code for your live script.

For interactive PID tuning in a standalone app, use PID Tuner. See “PID Controller Design for Fast Reference Tracking” for an example of designing a controller using the app.

Algorithms

zpk uses the MATLAB function `roots` to convert transfer functions and the functions `zero` and `pole` to convert state-space models.

Version History

Introduced before R2006a

See Also

`filt` | `frd` | `get` | `set` | `ss` | `zpkdata` | `genss` | `tf` | `realp` | `genmat`

Topics

“Transfer Functions”

“What Are Model Objects?”

“Discrete-Time Numeric Models”

“Using the Right Model Representation”

“Using FEEDBACK to Close Feedback Loops”

zpkdata

Access zero-pole-gain data

Syntax

```
[z,p,k] = zpkdata(sys)
[z,p,k,Ts] = zpkdata(sys)
[z,p,k,Ts,covz,covp,covk] = zpkdata(sys)
```

Description

`[z,p,k] = zpkdata(sys)` returns the zeros z , poles p , and gain(s) k of the zero-pole-gain model sys . The outputs z and p are cell arrays with the following characteristics:

- z and p have as many rows as outputs and as many columns as inputs.
- The (i,j) entries $z\{i,j\}$ and $p\{i,j\}$ are the (column) vectors of zeros and poles of the transfer function from input j to output i .

The output k is a matrix with as many rows as outputs and as many columns as inputs such that $k(i,j)$ is the gain of the transfer function from input j to output i . If sys is a transfer function or state-space model, it is first converted to zero-pole-gain form using `zpk`.

For SISO zero-pole-gain models, the syntax

```
[z,p,k] = zpkdata(sys,'v')
```

forces `zpkdata` to return the zeros and poles directly as column vectors rather than as cell arrays (see example below).

`[z,p,k,Ts] = zpkdata(sys)` also returns the sample time Ts .

`[z,p,k,Ts,covz,covp,covk] = zpkdata(sys)` also returns the covariances of the zeros, poles and gain of the identified model sys . `covz` is a cell array such that `covz{ky,ku}` contains the covariance information about the zeros in the vector $z\{ky,ku\}$. `covz{ky,ku}` is a 3-D array of dimension 2-by-2-by- N_z , where N_z is the length of $z\{ky,ku\}$, so that the $(1,1)$ element is the variance of the real part, the $(2,2)$ element is the variance of the imaginary part, and the $(1,2)$ and $(2,1)$ elements contain the covariance between the real and imaginary parts. `covp` has a similar relationship to p . `covk` is a matrix containing the variances of the elements of k .

You can access the remaining LTI properties of sys with `get` or by direct referencing, for example,

```
sys.Ts
sys.inputname
```

Examples

Example 1

Given a zero-pole-gain model with two outputs and one input

```
H = zpk({[0];[-0.5]},{[0.3];[0.1+i 0.1-i]],[1;2],-1)
Zero/pole/gain from input to output...
```

```
      z
#1:  -----
      (z-0.3)

      2 (z+0.5)
#2:  -----
      (z^2 - 0.2z + 1.01)
```

Sample time: unspecified

you can extract the zero/pole/gain data embedded in H with

```
[z,p,k] = zpkdata(H)
z =
      [      0]
      [-0.5000]
p =
      [      0.3000]
      [2x1 double]
k =
      1
      2
```

To access the zeros and poles of the second output channel of H, get the content of the second cell in z and p by typing

```
z{2,1}
ans =
      -0.5000
p{2,1}
ans =
      0.1000+ 1.0000i
      0.1000- 1.0000i
```

Example 2

Extract the ZPK matrices and their standard deviations for a 2-input, 1 output identified transfer function.

```
load iddata7
```

transfer function model

```
sys1 = tfest(z7, 2, 1, 'InputDelay',[1 0]);
```

an equivalent process model

```
sys2 = procest(z7, {'P2UZ', 'P2UZ'}, 'InputDelay',[1 0]);
```

```
1, p1, k1, ~, dz1, dp1, dk1] = zpkdata(sys1);
[z2, p2, k2, ~, dz2, dp2, dk2] = zpkdata(sys2);
```

Use `iopzplot` to visualize the pole-zero locations and their covariances

```
h = iopzplot(sys1, sys2);
showConfidence(h)
```

Version History

Introduced before R2006a

See Also

get | ssdata | tfdata | zpk

Blocks

Discrete Varying Lowpass

Discrete Butterworth filter with varying coefficients

Library: Control System Toolbox / Linear Parameter Varying

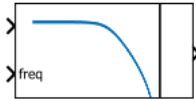

Discrete Varying Lowpass

Description

The block implements the Tustin discretization of a continuous-time N^{th} -order Butterworth filter. The result is a digital filter with unit DC gain and varying cutoff frequency.

Use this block and the other blocks in the Linear Parameter Varying library to implement common control elements with variable parameters or coefficients. For more information, see “Model Gain-Scheduled Control Systems in Simulink”.

Ports

Input

u – Filter input

scalar

Lowpass filter input signal.

freq – Cutoff frequency

scalar

Continuous-time value of the cutoff frequency, specified in rad/s.

Output

y – Filter output

scalar

Lowpass filter output signal.

Parameters

Filter order – Lowpass filter order

1 (default) | positive integer

Lowpass filter order, specified as a positive integer.

Pre-warping frequency w_0 (rad/s) – Pre-warping frequency

0 (default) | positive scalar

Pre-warping frequency, specified as a positive scalar. Discretization of the continuous-time Butterworth filter can shift the cutoff frequency when it is close to the Nyquist frequency. To ensure

that the analog and digital filters have matching frequency response near a particular frequency ω_0 , set this parameter to ω_0 . The default value $\omega_0 = 0$ corresponds to the bilinear (Tustin) transformation without pre-warp:

$$s = \frac{2}{T_s} \left(\frac{z-1}{z+1} \right),$$

where T_s is the block sample time, specified with the **Sample time Ts** parameter.

Sample time Ts – Sample time

1 (default) | positive scalar

Block sample time, specified as a positive scalar. This block does not support inherited sample time, because it requires a specified sample time to compute the discretization of the Butterworth filter.

Version History

Introduced in R2017b

Extended Capabilities

C/C++ Code Generation

Generate C and C++ code using Simulink® Coder™.

PLC Code Generation

Generate Structured Text code using Simulink® PLC Coder™.

See Also

Varying Lowpass Filter

Topics

“Model Gain-Scheduled Control Systems in Simulink”

Discrete Varying Notch

Discrete-time notch filter with varying coefficients

Library: Control System Toolbox / Linear Parameter Varying

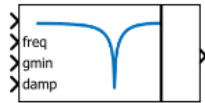

Discrete Varying Notch

Description

The block implements the Tustin discretization of a continuous-time notch filter with varying coefficients. Feed the continuous-time values of the notch frequency, minimum gain, and damping ratio to the **freq**, **gmin**, and **damp** input ports, respectively. These parameters control the notch depth and frequency of the continuous-time notch frequency as shown in the following illustration. The damping ratio **damp** controls the notch width Δ ; larger **damp** means larger Δ .

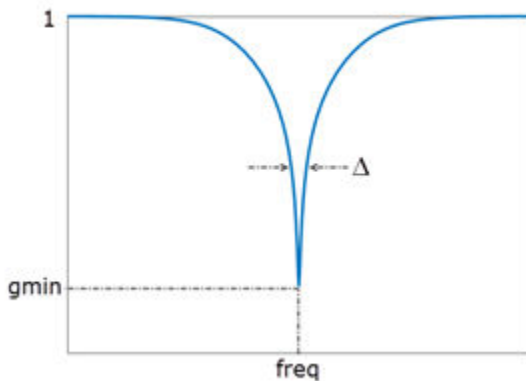

Use this block and the other blocks in the Linear Parameter Varying library to implement common control elements with variable parameters or coefficients. For more information, see “Model Gain-Scheduled Control Systems in Simulink”.

Ports

Input

u — Filter input

scalar

Notch filter input signal

freq — Notch frequency

scalar

Continuous-time value of the notch frequency, specified in rad/s.

gmin — Gain at notch frequency

scalar

Continuous-time value of the gain at notch frequency, in absolute units. This value controls the notch depth. The notch filter has unit gain at low and high frequency. The gain is lowest at the notch frequency.

damp — Damping ratio of the filter poles

scalar

Continuous-time value of the damping ratio, specified as a positive scalar value. The damping ratio controls the notch width; the closer to 0, the steeper the notch.

Output**y — Filter output**

scalar

Notch filter output signal.

Parameters**Pre-warping frequency ω_0 (rad/s) — Pre-warping frequency**

0 (default) | positive scalar

Pre-warping frequency, specified as a positive scalar. Discretization of the continuous-time notch-filter transfer function can shift the notch frequency when it is close to the Nyquist frequency. To ensure that the continuous and discrete filters have matching frequency response near a particular frequency ω_0 , set this parameter to ω_0 . The default value $\omega_0 = 0$ corresponds to the bilinear (Tustin) transformation without pre-warp:

$$s = \frac{2}{T_s} \left(\frac{z-1}{z+1} \right),$$

where T_s is the block sample time, specified with the **Sample time T_s** parameter.

Sample time T_s — Sample time

1 (default) | positive scalar

Block sample time, specified as a positive scalar. This block does not support inherited sample time, because it requires a specified sample time to compute the discretization of the notch filter.

Version History

Introduced in R2017b

Extended Capabilities**C/C++ Code Generation**

Generate C and C++ code using Simulink® Coder™.

PLC Code Generation

Generate Structured Text code using Simulink® PLC Coder™.

See Also

Varying Notch Filter

Topics

“Model Gain-Scheduled Control Systems in Simulink”

Discrete Varying Observer Form

Discrete-time observer-form state-space model with varying matrix values

Library: Control System Toolbox / Linear Parameter Varying

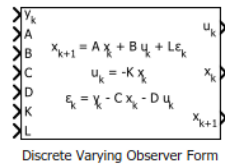

Description

Use this block to implement a discrete-time varying state-space model in observer form. The system matrices A , B , C , and D describe the plant dynamics, and the matrices K and L specify the state-feedback and state-observer gains, respectively. Feed the instantaneous values of these matrices to the corresponding input ports. The observer form is given by:

$$\begin{aligned}x_{k+1} &= Ax_k + Bu_k + L\varepsilon_k \\u_k &= -Kx_k \\ \varepsilon_k &= y_k - Cx_k - Du_k,\end{aligned}$$

where u_k is the plant input, y_k is the plant output, x_k is the estimated state, and ε_k is the innovation, the difference between the predicted and measured plant output. The observer form works well for gain scheduling of state-space controllers. In particular, the state x_k tracks the plant state, and all controllers are expressed with the same state coordinates.

Use this block and the other blocks in the Linear Parameter Varying library to implement common control elements with variable parameters or coefficients. For more information, see “Model Gain-Scheduled Control Systems in Simulink”.

Ports

Input

y_k — Measurement signal

scalar | vector

Measured plant output signal.

A — Plant state matrix

matrix

Plant state matrix of dimensions N_x -by- N_x , where N_x is the number of plant states.

B — Plant input matrix

matrix

Plant input matrix of dimensions N_x -by- N_u , where N_u is the number of plant inputs.

C — Plant output matrix

matrix

Plant output matrix of dimensions N_y -by- N_x , where N_y is the number of plant outputs.

D — Plant feedforward matrix

matrix

Plant feedforward matrix of dimensions N_y -by- N_u .

K — State-feedback matrix

matrix

State-feedback matrix of dimensions N_u -by- N_x .

L — State-observer matrix

matrix

State-observer matrix of dimensions N_x -by- N_y .

Output **u_k — Control signal**

scalar | vector

Control signal (plant input).

 x_k — Estimated plant state vector

vector

Vector of estimated plant states.

Dependencies

To enable this port, select the **Output states** parameter.

 x_{k+1} — Estimated next state vector

vector

Estimated state values at next time step.

Dependencies

To enable this port, select the **Output state updates** parameter.

Parameters**Initial conditions — System initial conditions**

0 (default) | scalar | vector

Initial state values, specified as a scalar or a vector whose length is the number of plant states.

Sample time (-1 for inherited) — Block sample time

-1 (default) | positive scalar

Block sample time, specified as either -1 (inherited sample time) or a positive scalar value.

Output states — Provide state output

on (default) | off

Select to enable the estimated states output port, \mathbf{x}_e .**Output state derivatives — Provide state updates**

on (default) | off

Select to enable the estimated state updates output port, \mathbf{x}_{k+1} .

Version History

Introduced in R2017b

Extended Capabilities

C/C++ Code Generation

Generate C and C++ code using Simulink® Coder™.

See Also

Varying Observer Form | Discrete Varying State Space

Topics

“Model Gain-Scheduled Control Systems in Simulink”

Discrete Varying State Space

Discrete-time state-space model with varying matrix values

Library: Control System Toolbox / Linear Parameter Varying

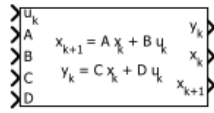

Discrete Varying State Space

Description

Use this block to implement a discrete-time state-space model with varying matrices. Feed the instantaneous values of the state matrix A , input matrix B , output matrix C , and feedforward matrix D to the corresponding input ports. The system response is given by:

$$\begin{aligned}x_{k+1} &= Ax_k + Bu_k \\ y_k &= Cx_k + Du_k,\end{aligned}$$

where u_k is the system input, y_k is the system output, x_k is the current system state, and x_{k+1} is the system state at the next time step.

Use this block and the other blocks in the Linear Parameter Varying library to implement common control elements with variable parameters or coefficients. For more information, see “Model Gain-Scheduled Control Systems in Simulink”.

Ports

Input

u_k — System input

scalar | vector

System input signal.

A — State matrix

matrix

State matrix of dimensions N_x -by- N_x , where N_x is the number of system states.

B — Input matrix

matrix

Input matrix of dimensions N_x -by- N_u , where N_u is the number of system inputs.

C — Output matrix

matrix

Output matrix N_y -by- N_x , where N_y is the number of system outputs.

D — Feedforward matrix

matrix

Feedforward matrix of dimensions N_y -by- N_u .

Output

y_k — System output

scalar | vector

System output signal.

x_k — Current state vector

vector

Current state values.

Dependencies

To enable this port, select the **Output states** parameter.

x_{k+1} — Next state vector

vector

State values at next time step.

Dependencies

To enable this port, select the **Output state updates** parameter.

Parameters

Initial conditions — System initial conditions

0 (default) | scalar | vector

Initial state values, specified as a scalar or a vector whose length is the number of system states.

Sample time (-1 for inherited) — Block sample time

-1 (default) | positive scalar

Block sample time, specified as either -1 (inherited sample time) or a positive scalar value.

Output states — Provide state output

on (default) | off

Select to enable the state values output port, x .

Output state derivatives — Provide state updates

on (default) | off

Select to enable the state updates output port, x_{k+1} .

Version History

Introduced in R2017b

Extended Capabilities

C/C++ Code Generation

Generate C and C++ code using Simulink® Coder™.

PLC Code Generation

Generate Structured Text code using Simulink® PLC Coder™.

See Also

Varying State Space

Topics

“Model Gain-Scheduled Control Systems in Simulink”

Discrete Varying Transfer Function

Discrete-time transfer function with varying coefficients

Library: Control System Toolbox / Linear Parameter Varying

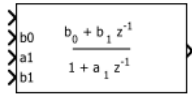

Discrete Varying Transfer Function

Description

This block implements a discrete-time transfer function with varying coefficients. The instantaneous transfer function is given by:

$$H(z) = \frac{b_0 + b_1/z + \dots + b_N/z^N}{1 + a_1/z + \dots + a_N/z^N},$$

where N is number of poles, specified with the **Transfer function order** parameter. Feed the values of the coefficients a_1, \dots, a_N and b_0, b_1, \dots, b_N to the corresponding block input ports.

Use this block and the other blocks in the Linear Parameter Varying library to implement common control elements with variable parameters or coefficients. For more information, see “Model Gain-Scheduled Control Systems in Simulink”.

Ports

Input

u — Transfer function input

scalar

Transfer function input signal.

b0, b1, ... — Numerator coefficients

scalar

Transfer function numerator coefficients. The number of coefficient ports is determined by the **Transfer function order** parameter.

a1, a2, ... — Denominator coefficients

scalar

Transfer function denominator coefficients. The number of coefficient ports is determined by the **Transfer function order** parameter.

Output

y — Transfer function output

scalar

Transfer function output signal.

Parameters

Transfer function order — Number of poles

1 (default) | positive integer

Transfer function (number of poles), specified as a positive integer. This parameter determines the number of coefficient input ports on the block.

Sample time (-1 for inherited) — Block sample time

-1 (default) | positive scalar

Block sample time, specified as either -1 (inherited sample time) or a positive scalar value.

Version History

Introduced in R2017b

Extended Capabilities

C/C++ Code Generation

Generate C and C++ code using Simulink® Coder™.

PLC Code Generation

Generate Structured Text code using Simulink® PLC Coder™.

See Also

Varying Transfer Function

Topics

“Model Gain-Scheduled Control Systems in Simulink”

Kalman Filter

Estimate states of discrete-time or continuous-time linear system

Library: Control System Toolbox / State Estimation
System Identification Toolbox / Estimators

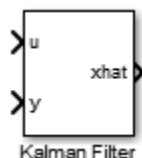

Description

Use the Kalman Filter block to estimate states of a state-space plant model given process and measurement noise covariance data. The state-space model can be time-varying. A steady-state Kalman filter implementation is used if the state-space model and noise covariance matrices are all time-invariant, and a time-varying Kalman filter is used otherwise.

A Kalman filter provides the optimal solution to the continuous or discrete estimation problems in “Continuous-Time Estimation” (System Identification Toolbox) and “Discrete-Time Estimation” (System Identification Toolbox).

The Kalman Filter block differs from the `kalman` command in the following ways:

- When you call `kalman(sys, ...)`, it assumes that `sys` includes the `G` and `H` matrices. Specifically, `sys.B` is of the form `[B G]` and `sys.D` is of the form `[D H]`. When you provide a LTI variable to the Kalman Filter block, it does not assume that the LTI variable provided contains `G` and `H`. They are optional and separate.
- The filter created by the `kalman` command outputs `[yhat;xhat]` by default. The block outputs only `xhat` by default.
- The `Kalman` command can output both `P` and `Z` covariance matrices for discrete-time systems. The block can only output `P` or `Z` for such systems.

Limitations

- The plant and noise data must satisfy these constraints:
 - (C,A) is detectable.
 - $\bar{R} > 0$ and $\bar{Q} - \bar{N}\bar{R}^{-1}\bar{N}^T \geq 0$.
 - $(A - \bar{N}\bar{R}^{-1}C, \bar{Q} - \bar{N}\bar{R}^{-1}\bar{N}^T)$ has no uncontrollable mode on the imaginary axis (or unit circle in discrete time), where

$$\bar{Q} = GQG^T$$

$$\bar{R} = R + HN + N^T H^T + HQH^T$$

$$\bar{N} = G(QH^T + N)$$

- The continuous-time Kalman filter cannot be used in Function-Call Subsystems or Triggered Subsystems.

Ports

Input

u – Known inputs

scalar | vector

Known inputs $u(t)$ or $u[k]$.

Dependencies

To enable this port, select the **Add input port u** parameter. This parameter is selected by default.

y – Measured outputs

scalar | vector

Measured output $y[n]$ to update the estimated states.

A – State matrix

real matrix

n -by- n state (or system) matrix.

Dependencies

To enable this port, set the **Model source** parameter to **Input Port**.

B – Input matrix

real matrix

n -by- p input matrix.

Dependencies

To enable this port, set the **Model source** parameter to **Input Port** and select the **Add input port u** parameter.

C – Output matrix

real matrix

q -by- p output matrix.

Dependencies

To enable this port, set the **Model source** parameter to **Input Port**.

D – Feedthrough matrix

real matrix

q -by- p feedthrough (or feedforward) matrix. In cases where the system model does not have a direct feedthrough, **D** is the zero matrix.

Dependencies

To enable this port, set the **Model source** parameter to **Input Port** and select the **Add input port u** parameter.

G — Measured outputs

real matrix

Noise transformation in the state-space equation.

Dependencies

To enable this port, select **Use G and H matrices (default G=I and H=0)** parameter.

H — Measured outputs

real matrix

Noise transformation in the state-space equation.

Dependencies

To enable this port, select **Use G and H matrices (default G=I and H=0)** parameter.

Q — Process noise covariance matrix

scalar | vector | matrix

Process noise covariance matrix, specified as one of the following:

- Real nonnegative scalar. **Q** is an N_w -by- N_w diagonal matrix with the scalar on the diagonals. N_w is the number of process noise inputs in the model.
- Vector of real nonnegative scalars. **Q** is an N_w -by- N_w diagonal matrix with the elements of the vector on the diagonals of **Q**.
- N_w -by- N_w positive semi-definite matrix.

Dependencies

To enable this port, deselect the **Time-invariant Q** parameter.

R — Measurement noise covariance matrix

scalar | vector | matrix

Measurement noise covariance matrix, specified as one of the following:

- Real positive scalar. **R** is an N_y -by- N_y diagonal matrix with the scalar on the diagonals. N_y is the number of measured outputs in the model.
- Vector of real positive scalars. **R** is an N_y -by- N_y diagonal matrix with the elements of the vector on the diagonals of **R**.
- N_y -by- N_y positive-definite matrix.

Dependencies

To enable this port, deselect the **Time-invariant R** parameter.

N — Process and measurement noise cross-covariance matrix

scalar | vector | matrix

Process and measurement noise cross-covariance matrix, specified as a N_w -by- N_y matrix. The matrix $[Q \ N; \ N^T \ R]$ must be positive definite.

Dependencies

To enable this port, deselect the **Time-invariant N** parameter.

P0 — Initial state estimation error covariance

scalar | vector | matrix

P matrix at the initial time.

Dependencies

To enable this port, set the **Model source** parameter to **Input Port** and set the **Source** parameter to **Input Port**.

X0 — Initial state estimates

scalar | vector

Estimated states at the initial time.

Dependencies

To enable this port, set the **Source** parameter to **Input Port**.

Enable — Control signal to enable measurement updates

scalar

This port controls the measurement updates and takes a scalar signal.

Dependencies

To enable this port, select **Add input port Enable to control measurement updates** parameter.

Reset — Control signal to reset state estimates

scalar

Control signal to reset estimated states and the parameter covariance matrix using specified initial values. See “External Reset” (System Identification Toolbox) for more information on when a reset is triggered.

Dependencies

To enable this port, set the **External reset** parameter to any value other than **None**.

Output**xhat — Estimated states**

scalar | vector

Estimated states of the linear system.

yhat — Estimated outputs

scalar | vector

Estimated outputs of the linear system.

Dependencies

To enable this port, select **Output estimated model output y** parameter.

Z — State estimation error covariance

matrix

Add **Z** output port to the block.

To enable this port, select **Output state estimation error covariance Z** parameter.

Dependencies

To enable this port, set the **Time domain** parameter to **Discrete-Time** and select **Use the current measurement $y[n]$ to improve $\hat{x}[n]$** parameter.

P — State estimation error covariance

matrix

Add **P** output port to the block.

To enable this port, select **Output state estimation error covariance P** parameter.

Dependencies

To enable this port, set the **Time domain** parameter to **Continuous-Time** or set the **Time domain** parameter to **Discrete-Time** and deselect **Use the current measurement $y[n]$ to improve $\hat{x}[n]$** parameter.

Note

- All input ports except **Enable** and **Reset** must have the same data type (single or double).
- **Enable** and **Reset** ports support single, double, int8, uint8, int16, uint16, int32, uint32, and boolean data types.

Parameters**Filter Settings****Time domain — Specify whether to estimate continuous-time or discrete-time states**

Discrete-Time (default) | Continuous-Time

- Discrete-Time (default) — Block estimates discrete-time states.
- Continuous-Time — Block estimates continuous-time states.

When the Kalman Filter block is in a model with synchronous state control (see the State Control block), you cannot select **Continuous-Time**.

Programmatic Use**Block Parameter:** TimeDomain**Type:** string, character vector**Values:** "Discrete-Time" | "Continuous-Time"**Default:** "Discrete-Time"**Use the current measurement $y[n]$ to improve $\hat{x}[n]$ — Update output state estimates using the measure outputs**

on (default) | off

Use the current estimator variant of the discrete-time Kalman filter. When this parameter is not selected, the delayed estimator (variant) is used.

This parameter is available only when **Time domain** is **Discrete-Time**.

Programmatic Use

Block Parameter: UseCurrentEstimator

Type: string, character vector

Values: "off" | "on"

Default: "on"

Sample Time — Block sample time

-1 (default) | non-negative scalar

Block sample time, specified as -1 or a positive scalar.

The default value is -1, which implies that the block inherits its sample time based on the context of the block within the model. All block input ports must have the same sample time.

Dependencies

This parameter is available only when **Time domain** is **Discrete-Time** and **Model source** is **Individual A, B, C, D matrices** or **Input port**. The sample time is obtained from the LTI state-space variable **Model source** is **LTI State-Space Variable**.

Programmatic Use

Block Parameter: Ts

Type: string, character vector

Values: "-1" | scalar

Default: "-1"

Model Parameters

System Model

Model source — Specify how the A, B, C, D matrices are provided to the block

LTI State-Space Variable (default) | Individual A, B, C, D matrices | Input port

- **LTI State-Space Variable** — Use the model specified in **Variable**. The default value is `ss(0.95, 1, 1, 0)`. The sample time of the model must match the **Time domain** parameter; that is, the model must be discrete-time if **Time domain** is discrete-time.
- **Individual A, B, C, D matrices** — Specify the **A**, **B**, **C**, and **D** in the block parameters.
- **Input port** — Specify the **A**, **B**, **C**, **D** matrices as input signals to the Kalman Filter block. If you select this option, the block includes additional input ports **A**, **B**, **C**, **D**. You must also specify **Number of states**, **Number of inputs**, and **Number of outputs** in the block parameters.

Programmatic Use

Block Parameter: ModelSource

Type: string, character vector

Values: "LTI State-Space Variable" | "Individual A, B, C, D matrices" | "Input port"

Default: "LTI State-Space Variable"

A — State Matrix

0.95 (default)

Specify the **A** matrix. It must be real and square. The default value is 0.95.

Dependencies

To enable this port, set the **Model source** parameter to **Individual A, B, C, D matrices**.

Programmatic Use

Block Parameter: A

Type: string, character vector

Values: "real matrix"

Default: "0.95"

B — Input Matrix

1 (default)

Specify the **B** matrix. It must be real and have as many rows as the **A** matrix. The default value is 1.

Dependencies

To enable this port, set the **Model source** parameter to **Individual A, B, C, D matrices**.

Programmatic Use

Block Parameter: B

Type: string, character vector

Values: "real matrix"

Default: "1"

C — Output Matrix

1 (default)

Specify the **C** matrix. It must be real and have as many columns as the **A** matrix. The default value is 1.

Dependencies

To enable this port, set the **Model source** parameter to **Individual A, B, C, D matrices**.

Programmatic Use

Block Parameter: C

Type: string, character vector

Values: "real matrix"

Default: "1"

D — Feedthrough Matrix

0 (default)

Specify the **D** matrix. It must be real and must have as many rows as the **C** matrix and as many columns as the **B** matrix. The default value is 0.

Dependencies

To enable this port, set the **Model source** parameter to **Individual A, B, C, D matrices**.

Programmatic Use

Block Parameter: D

Type: string, character vector

Values: "real matrix"

Default: "0"

Number of states — Number of states to be estimated

1 (default) | non-negative scalar

Number of states to be estimated, specified as a positive integer. The default value is 1.

Dependencies

To enable this port, set the **Model source** parameter to **Input port**.

Programmatic Use

Block Parameter: NumberOfStates

Type: string, character vector

Values: "1" | scalar

Default: "1"

Number of inputs — Number of known inputs

1 (default) | non-negative scalar

Number of known inputs in the model, specified as a positive integer. The default value is 1.

Dependencies

To enable this port, set the **Model source** parameter to **Input port**.

Programmatic Use

Block Parameter: NumberOfInputs

Type: string, character vector

Values: "1" | scalar

Default: "1"

Number of outputs — Number of measured output

1 (default) | non-negative scalar

Number of measured outputs in the model, specified as a positive integer. The default value is 1.

Dependencies

To enable this port, set the **Model source** parameter to **Input port**.

Programmatic Use

Block Parameter: NumberOfOutputs

Type: string, character vector

Values: "1" | scalar

Default: "1"

Initial Estimates

Source — Specify how to enter the initial state estimates and initial state estimation error covariance

Dialog (default) | Input port

- **Dialog** — Specify the values directly in the dialog boxes.
- **Input port** — Inherit the values from input ports. The default is 10. The block includes an additional input port **X0**. A second additional input port **P0** is added when time-varying Kalman filter is used. **X0** and **P0** must satisfy the same conditions as the parameters Initial states $x[0]$ and State estimation error covariance $P[0]$, respectively.

Programmatic Use**Block Parameter:** InitialEstimateSource**Type:** string, character vector**Values:** "Dialog" | "Input port"**Default:** "Dialog"**Initial states $x[0]$ — Specify the initial state estimate** 0 (default) | scalar | vector

Specify the initial state estimate as a real scalar or vector. If you specify a scalar, all initial state estimates are set to this scalar. If you specify a vector, the length of the vector must match with the number of states in the model. The default is 0 .

Dependencies

To enable this port, set the **Source** parameter to **Dialog**.

Programmatic Use**Block Parameter:** X0**Type:** string, character vector**Values:** "0" | scalar | vector**Default:** "0"**State estimation error covariance $P[0]$ — Specify the initial state estimation error covariance** 10 (default) | scalar | vector | matrix

Specify the initial state estimation error covariance $P[0]$ for a discrete-time Kalman filter or $P(0)$ for continuous-time. This parameter must be specified as one of the following:

- Real nonnegative scalar. \mathbf{P} is an N_s -by- N_s diagonal matrix with the scalar on the diagonals. N_s is the number of states in the model.
- Vector of real nonnegative scalars. \mathbf{P} is an N_s -by- N_s diagonal matrix with the elements of the vector on the diagonals of \mathbf{P} .
- N_s -by- N_s positive semi-definite matrix.

Dependencies

To enable this port, set the **Model source** parameter to **Input port** and **Source** parameter to **Dialog**.

Programmatic Use**Block Parameter:** P0**Type:** string, character vector**Values:** "10" | scalar | vector | matrix**Default:** "10"**Noise Characteristics****Use the Kalman Gain K from the model variable — Specify whether to use pre-identified Kalman Gain contained in state-space plant model**

off (default) | on

Specify whether to use the pre-identified Kalman Gain present in the state-space model specified by **Variable**.

Dependencies

To enable this parameter, you must meet the following conditions:

- The **Model source** is set to **LTI State-Space Variable** and **Variable** is an identified state-space model (idss) with a nonzero **K** matrix.
- Select the **Time Invariant Q**, **Time Invariant R**, and **Time Invariant N** parameters.
- If the **Use G and H matrices (default G=I and H=0)** parameter is selected, the **Time Invariant G** and **Time Invariant H** parameters must also be selected.

Programmatic Use

Block Parameter: UseK

Type: string, character vector

Values: "off" | "on"

Default: "off"

Use G and H matrices (default G=I and H=0) — Specify whether to use non-default values for G and H matrices

off (default) | on

By default $G=I$ and $H=0$. If you select this option, you must specify **G** and **H** parameter.

Programmatic Use

Block Parameter: UseGH

Type: string, character vector

Values: "off" | "on"

Default: "off"

G — Specify the G matrix

1 (default) | non-negative scalar | vector | matrix

It must be a real matrix with as many rows as the **A** matrix. The default value is 1.

Dependencies

To enable this parameter, select **Use G and H matrices (default G=I and H=0)** parameter.

Programmatic Use

Block Parameter: G

Type: string, character vector

Values: scalar | vector | matrix

Default: "1"

Time-invariant G — Specify the G matrix is time invariant

on (default) | off

If you unselect this option, the block includes an additional input port **G**.

Programmatic Use

Block Parameter: TimeInvariantG

Type: string, character vector

Values: "off" | "on"

Default: "on"

H — Specify the H matrix

0 (default) | non-negative scalar | vector | matrix

It must be a real matrix with as many rows as the **C** matrix and as many columns as the **G** matrix. The default value is 0.

Dependencies

To enable this parameter, select **Use G and H matrices (default G=I and H=0)** parameter.

Programmatic Use

Block Parameter: H

Type: string, character vector

Values: scalar | vector | matrix

Default: "0"

Time-invariant H — Specify the H matrix is time invariant

on (default) | off

If you unselect this option, the block includes an additional input port **H**.

Programmatic Use

Block Parameter: TimeInvariantH

Type: string, character vector

Values: "off" | "on"

Default: "on"

Number of process noise inputs — Process noise inputs

1 (default) | non-negative scalar

Specify the number of process noise inputs in the model. The default value is 1.

Dependencies

This parameter is available only when **Time-invariant G** and **Time-invariant H** are deselected. Otherwise, this information is inferred from the **G** or **H** matrix.

Programmatic Use

Block Parameter: NumberOfProcessNoiseInputs

Type: string, character vector

Values: scalar

Default: "1"

Q — Process noise covariance matrix

0.05 (default) | non-negative scalar | vector | matrix

Specified as one of the following:

- Real nonnegative scalar. **Q** is an N_w -by- N_w diagonal matrix with the scalar on the diagonals. N_w is the number of process noise inputs in the model.
- Vector of real nonnegative scalars. **Q** is an N_w -by- N_w diagonal matrix with the elements of the vector on the diagonals of **Q**.
- N_w -by- N_w positive semi-definite matrix.

Dependencies

To enable this parameter, select the **Time-invariant Q** parameter.

Programmatic Use**Block Parameter:** Q**Type:** string, character vector**Values:** scalar | vector | matrix**Default:** "0.05"**Time-invariant Q — Specify if Q matrix is time invariant**

on (default) | off

If you deselect this parameter, the block includes an additional input port **Q**.

Programmatic Use**Block Parameter:** TimeInvariantQ**Type:** string, character vector**Values:** "off" | "on"**Default:** "on"**R — Measurement noise covariance matrix**

1 (default) | non-negative scalar | vector | matrix

Specified as one of the following:

- Real positive scalar. **R** is an N_y -by- N_y diagonal matrix with the scalar on the diagonals. N_y is the number of measured outputs in the model.
- Vector of real positive scalars. **R** is an N_y -by- N_y diagonal matrix with the elements of the vector on the diagonals of **R**.
- N_y -by- N_y positive-definite matrix.

Dependencies

To enable this parameter, select the **Time-invariant R** parameter.

Programmatic Use**Block Parameter:** R**Type:** string, character vector**Values:** scalar | vector | matrix**Default:** "1"**Time-invariant R — Specify if R matrix is time invariant**

on (default) | off

If you deselect this parameter, the block includes an additional input port **R**.

Programmatic Use**Block Parameter:** TimeInvariantR**Type:** string, character vector**Values:** "off" | "on"**Default:** "on"**N — Process and measurement noise cross-covariance matrix**

0 (default) | non-negative scalar | vector | matrix

Specify this parameter as a N_w -by- N_y matrix. The matrix $[Q \ N; \ N^T \ R]$ must be positive definite.

Dependencies

To enable this parameter, select the **Time-invariant N** parameter.

Programmatic Use

Block Parameter: N

Type: string, character vector

Values: scalar | vector | matrix

Default: "0"

Time-invariant N — Specify if N matrix is time invariant

on (default) | off

If you deselect this parameter, the block includes an additional input port **N**.

Programmatic Use

Block Parameter: TimeInvariantN

Type: string, character vector

Values: "off" | "on"

Default: "on"

Options

Additional Inports

Add input port **u** — Specify if model contains known inputs

on (default) | off

Select this option if your model contains known inputs $u(t)$ or $u[k]$. The parameter is selected by default. Deselecting this parameter removes the input port **u** from the block and removes the **B**, **D** and **Number of inputs** parameters from the block dialog box.

Programmatic Use

Block Parameter: AddInputPort

Type: string, character vector

Values: "off" | "on"

Default: "on"

Add input port **Enable** to control measurement updates — Control the measurement updates

off (default) | on

Select this option if you want to control the measurement updates. The block includes an additional inport **Enable**. The **Enable** input port takes a scalar signal. This parameter is not selected by default.

By default the block does measurement updates at each time step to improve the state and output estimates \hat{x} and \hat{y} based on measured outputs. The measurement update is skipped for the current sample time when the signal in the **Enable** port is 0. Concretely, the equation for state estimates become $\hat{x}(t) = A(t)\hat{x}(t) + B(t)u(t)$ for a continuous-time Kalman filter and $\hat{x}[n + 1 | n] = A[n]\hat{x}[n | n - 1] + B[n]u[n]$ for discrete-time.

Note Enabling the **Enable** port allows measurement updates to be controlled. By default, Kalman Filter does the measurement updates.

Programmatic Use**Block Parameter:** AddEnablePort**Type:** string, character vector**Values:** "off" | "on"**Default:** "off"**External Reset — Option to reset estimated states and parameter covariance matrix using specified initial values**

None (default) | Rising | Falling | Either | Level | Level hold

This parameter helps control when the block is reset. Suppose you reset the block at a time step, t . If the block is enabled at t , the software uses the initial parameter values specified either in the block dialog or the input ports **P0** and **X0** to estimate the states. In other words, at t , the block performs a time update and, if it is enabled, a measurement update after the reset. The block outputs these updated estimates.

Specify one of the following:

- **None (Default)** — Estimated states \hat{x} and state estimation error covariance matrix **P** values are not reset.
- **Rising** — Triggers a reset when the control signal rises from a negative or zero value to a positive value. If the initial value is negative, rising to zero triggers a reset.
- **Falling** — Triggers a reset when the control signal falls from a positive or zero value to a negative value. If the initial value is positive, falling to zero triggers a reset.
- **Either** — Triggers a reset when the control signal is either rising or falling.
- **Level** — Triggers a reset in either of these cases:
 - The control signal is nonzero at the current time step.
 - The control signal changes from nonzero at the previous time step to zero at the current time step.
- **Level hold** — Triggers reset when the control signal is nonzero at the current time step.

When you choose an option other than **None**, a **Reset** input port is added to the block to provide the reset control input signal.

Programmatic Use**Block Parameter:** ExternalReset**Type:** string, character vector**Values:** "None" | "Rising" | "Falling" | "Either" | "Level" | "Level hold"**Default:** "None"**Additional Outputs****Output estimated model output \hat{y} — Include estimated model outputs**

off (default) | on

Add a \hat{y} output port to the block to output the estimated model outputs. The parameter is not selected by default.

Programmatic Use**Block Parameter:** OutputEstimatedY**Type:** string, character vector**Values:** "off" | "on"

Default: "off"

Output state estimation error covariance Z — Add Z output port to the block

off (default) | on

Add a **Z** output port to the block. The **Z** matrix is provided only when **Time domain** is **Discrete-Time** and the **Use the current measurement $y[n]$ to improve $\hat{x}[n]$** parameter is selected. Otherwise, the **P** matrix, as described in the “Algorithms” (System Identification Toolbox) section, is provided.

This parameter is not selected by default.

Programmatic Use

Block Parameter: OutputZ

Type: string, character vector

Values: "off" | "on"

Default: "off"

Output state estimation error covariance P — Add P output port to the block

off (default) | on

Add a **P** output port to the block. This parameter is not selected by default.

Dependencies

To enable this port, set the **Time domain** parameter to **Continuous-Time** or set the **Time domain** parameter to **Discrete-Time** and deselect **Use the current measurement $y[n]$ to improve $\hat{x}[n]$** parameter.

Programmatic Use

Block Parameter: OutputP

Type: string, character vector

Values: "off" | "on"

Default: "off"

Algorithms

Continuous-Time Estimation

Given the continuous plant

$$\dot{x}(t) = A(t)x(t) + B(t)u(t) + G(t)w(t) \quad (\text{state equation})$$

$$y(t) = C(t)x(t) + D(t)u(t) + H(t)w(t) + v(t) \quad (\text{measurement equation})$$

with known inputs u , white process noise w , and white measurement noise v satisfying

$$E[w(t)] = E[v(t)] = 0$$

$$E[w(t)w^T(t)] = Q(t)$$

$$E[w(t)v^T(t)] = N(t)$$

$$E[v(t)v^T(t)] = R(t)$$

construct a state estimate \hat{x} that minimizes the state estimation error covariance

$$P(t) = E[(x - \hat{x})(x - \hat{x})^T].$$

The optimal solution is the Kalman filter with equations

$$\begin{aligned} L(t) &= (P(t)C^T(t) + \bar{N}(t))\bar{R}^{-1}(t), \\ \dot{P}(t) &= A(t)P(t) + P(t)A^T(t) + \bar{Q}(t) - L(t)\bar{R}(t)L^T(t), \\ \dot{\hat{x}}(t) &= A(t)\hat{x}(t) + B(t)u(t) + L(t)(y(t) - C(t)\hat{x}(t) - D(t)u(t)), \end{aligned}$$

where

$$\begin{aligned} \bar{Q}(t) &= G(t)Q(t)G^T(t), \\ \bar{R}(t) &= R(t) + H(t)N(t) + N^T(t)H^T(t) + H(t)Q(t)H^T(t), \\ \bar{N}(t) &= G(t)(Q(t)H^T(t) + N(t)). \end{aligned}$$

The Kalman filter uses known inputs u and measurements y to generate state estimates \hat{x} . If you want, the block can also output the estimates of the true plant output \hat{y} .

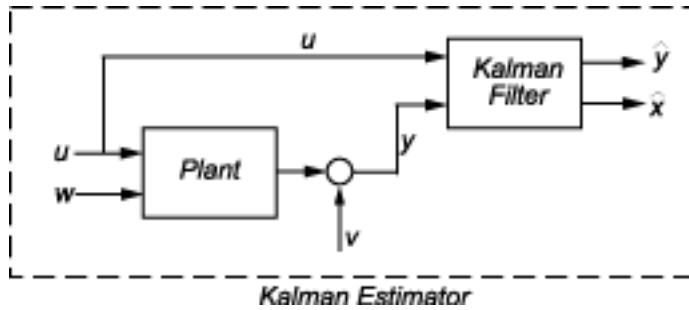

The block implements the steady-state Kalman filter when the system matrices ($A(t)$, $B(t)$, $C(t)$, $D(t)$, $G(t)$, $H(t)$) and noise covariance matrices ($Q(t)$, $R(t)$, $N(t)$) are constant (specified in the Block Parameters dialog box). The steady-state Kalman filter uses a constant matrix P that minimizes the steady-state estimation error covariance and solves the associated continuous-time algebraic Riccati equation:

$$P = \lim_{t \rightarrow \infty} E[(x - \hat{x})(x - \hat{x})^T].$$

Discrete-Time Estimation

Consider the discrete plant

$$\begin{aligned} x[n+1] &= A[n]x[n] + B[n]u[n] + G[n]w[n], \\ y[n] &= C[n]x[n] + D[n]u[n] + H[n]w[n] + v[n], \end{aligned}$$

with known inputs u , white process noise w , and white measurement noise v satisfying

$$\begin{aligned} E[w[n]] &= E[v[n]] = 0, \\ E[w[n]w^T[n]] &= Q[n], \\ E[v[n]v^T[n]] &= R[n], \\ E[w[n]v^T[n]] &= N[n]. \end{aligned}$$

The estimator has the following state equation

$$\hat{x}[n+1|n] = A[n]\hat{x}[n|n-1] + B[n]u[n] + L[n](y[n] - C[n]\hat{x}[n|n-1] - D[n]u[n]),$$

where the gain $L[n]$ is calculated through the discrete Riccati equation:

$$L[n] = (A[n]P[n]C^T[n] + \bar{N}[n])C,$$

$$M[n] = P[n]C^T[n]C,$$

$$Z[n] = (I - M[n]C[n])P[n] + M[n]\bar{R}[n]M^T[n],$$

$$P[n+1] = (A[n] - \bar{N}[n]\bar{R}^{-1}[n]C[n])Z[n] + \bar{Q}[n] - N[n]\bar{R}^{-1}[n]\bar{N}^T[n],$$

where I is the identity matrix of appropriate size and

$$\bar{Q}[n] = G[n]Q[n]G^T[n],$$

$$\bar{R}[n] = R[n] + H[n]N[n] + N^T[n]H^T[n] + H[n]Q[n]H^T[n],$$

$$\bar{N}[n] = G[n](Q[n]H^T[n] + N[n]),$$

and

$$P[n] = E[(x - \hat{x}[n|n-1])(x - \hat{x}[n|n-1])^T],$$

$$Z[n] = E[(x - \hat{x}[n|n])(x - \hat{x}[n|n])^T],$$

The steady-state Kalman filter uses a constant matrix P that minimizes the steady-state estimation error covariance and solves the associated discrete-time algebraic Riccati equation.

There are two variants of discrete-time Kalman filters:

- The current estimator generates the state estimates $\hat{x}[n|n]$ using all measurements available, including $y[n]$. The filter updates $\hat{x}[n|n-1]$ with $y[n]$ and outputs:

$$\hat{x}[n|n] = \hat{x}[n|n-1] + M[n](y[n] - C[n]\hat{x}[n|n-1] - D[n]u[n]),$$

$$\hat{y}[n|n] = C[n]\hat{x}[n|n] + D[n]u[n].$$

- The delayed estimator generates the state estimates $\hat{x}[n|n-1]$ using measurements up to $y[n-1]$. The filter outputs $\hat{x}[n|n-1]$ as defined previously, along with the optional output

$$\hat{y}[n|n-1] = C[n]\hat{x}[n|n-1] + D[n]u[n]$$

The current estimator has better estimation accuracy than the delayed estimator, which is important for slow sample times. However, it has a higher computational cost, so implementing it inside control loops is harder. More specifically, it has direct feedthrough which leads to an algebraic loop if the Kalman filter is used in a feedback loop that does not contain any delays (the feedback loop itself also has direct feedthrough). This algebraic loop can impact the speed of simulation, and you cannot generate code if your model contains algebraic loops.

Version History

Introduced in R2014b

R2021a: Kalman Filter block: Numerical changes

Starting in 2021a, numerical improvements in the algorithms used by the Kalman Filter block might produce results that are different from the results you obtained using previous versions.

References

- [1] Franklin, Gene F., J. David Powell, and Michael L. Workman. *Digital Control of Dynamic Systems*. 2nd ed. Reading, Mass: Addison-Wesley, 1990.
- [2] Lewis, Frank L. *Optimal Estimation: With an Introduction to Stochastic Control Theory*. New York: Wiley, 1986.

Extended Capabilities

C/C++ Code Generation

Generate C and C++ code using Simulink® Coder™.

PLC Code Generation

Generate Structured Text code using Simulink® PLC Coder™.

See Also

Functions

`kalman` | `extendedKalmanFilter` | `unscentedKalmanFilter` | `kalmd` | `particleFilter`

Blocks

Extended Kalman Filter | Unscented Kalman Filter | Particle Filter

Topics

“Validate Online State Estimation in Simulink”

“Troubleshoot Online State Estimation”

Extended Kalman Filter

Estimate states of discrete-time nonlinear system using extended Kalman filter

Library: Control System Toolbox / State Estimation
System Identification Toolbox / Estimators

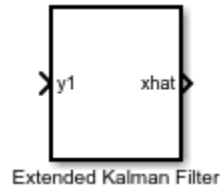

Description

The Extended Kalman Filter block estimates the states of a discrete-time nonlinear system using the first-order discrete-time extended Kalman filter algorithm.

Consider a plant with states x , input u , output y , process noise w , and measurement noise v . Assume that you can represent the plant as a nonlinear system.

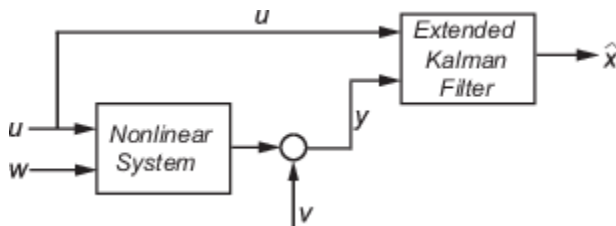

Using the state transition and measurement functions of the system and the extended Kalman filter algorithm, the block produces state estimates \hat{x} for the current time step. For information about the algorithm, see “Extended and Unscented Kalman Filter Algorithms for Online State Estimation”.

You create the nonlinear state transition function and measurement functions for the system and specify these functions in the block. The block supports state estimation of a system with multiple sensors that are operating at different sampling rates. You can specify up to five measurement functions, each corresponding to a sensor in the system. You can also specify the Jacobians of the state transition and measurement functions. If you do not specify them, the software numerically computes the Jacobians. For more information, see “State Transition and Measurement Functions” on page 3-46.

Ports

Input

$y1, y2, y3, y4, y5$ – Measured system outputs

vector

Measured system outputs corresponding to each measurement function that you specify in the block. The number of ports equals the number of measurement functions in your system. You can specify up to five measurement functions. For example, if your system has two sensors, you specify two

measurement functions in the block. The first port **y1** is available by default. When you click **Apply**, the software generates port **y2** corresponding to the second measurement function.

Specify the ports as N -dimensional vectors, where N is the number of quantities measured by the corresponding sensor. For example, if your system has one sensor that measures the position and velocity of an object, then there is only one port **y1**. The port is specified as a 2-dimensional vector with values corresponding to position and velocity.

Dependencies

The first port **y1** is available by default. Ports **y2** to **y5** are generated when you click **Add Measurement**, and click **Apply**.

Data Types: `single` | `double`

StateTransitionFcnInputs — Additional optional input argument to state transition function

scalar | vector | matrix

Additional optional input argument to the state transition function f other than the state x and process noise w . For information about state transition functions see, “State Transition and Measurement Functions” on page 3-46.

Suppose that your system has nonadditive process noise, and the state transition function f has the following form:

$$x(k+1) = f(x(k), w(k), \text{StateTransitionFcnInputs})$$

Here k is the time step, and `StateTransitionFcnInputs` is an additional input argument other than x and w .

If you create f using a MATLAB function (`.m` file), the software generates the port **StateTransitionFcnInputs** when you click **Apply**. You can specify the inputs to this port as a scalar, vector, or matrix.

If your state transition function has more than one additional input, use a Simulink Function block to specify the function. When you use a Simulink Function block, you provide the additional inputs directly to the Simulink Function block using Inport blocks. No input ports are generated for the additional inputs in the Extended Kalman Filter block.

Dependencies

This port is generated only if both of the following conditions are satisfied:

- You specify f in **Function** using a MATLAB function, and f is on the MATLAB path.
- f requires only one additional input argument apart from x and w .

Data Types: `single` | `double`

MeasurementFcn1Inputs, MeasurementFcn2Inputs, MeasurementFcn3Inputs, MeasurementFcn4Inputs, MeasurementFcn5Inputs — Additional optional input argument to each measurement function

scalar | vector | matrix

Additional optional inputs to the measurement functions other than the state x and measurement noise v . For information about measurement functions see, “State Transition and Measurement Functions” on page 3-46.

MeasurementFcn1Inputs corresponds to the first measurement function that you specify, and so on. For example, suppose that your system has three sensors and nonadditive measurement noise, and the three measurement functions h_1 , h_2 , and h_3 have the following form:

$$y_1[k] = h_1(x[k], v_1[k], \text{MeasurementFcn1Inputs})$$

$$y_2[k] = h_2(x[k], v_2[k], \text{MeasurementFcn2Inputs})$$

$$y_3[k] = h_3(x[k], v_3[k])$$

Here k is the time step, and **MeasurementFcn1Inputs** and **MeasurementFcn2Inputs** are the additional input arguments to h_1 and h_2 .

If you specify h_1 , h_2 , and h_3 using MATLAB functions (.m files) in **Function**, the software generates ports **MeasurementFcn1Inputs** and **MeasurementFcn2Inputs** when you click **Apply**. You can specify the inputs to these ports as scalars, vectors, or matrices.

If your measurement functions have more than one additional input, use Simulink Function blocks to specify the functions. When you use a Simulink Function block, you provide the additional inputs directly to the Simulink Function block using Inport blocks. No input ports are generated for the additional inputs in the Extended Kalman Filter block.

Dependencies

A port corresponding to a measurement function h is generated only if both of the following conditions are satisfied:

- You specify h in **Function** using a MATLAB function, and h is on the MATLAB path.
- h requires only one additional input argument apart from x and v .

Data Types: `single` | `double`

Q — Time-varying process noise covariance

scalar | vector | matrix

Time-varying process noise covariance, specified as a scalar, vector, or matrix depending on the value of the **Process noise** parameter:

- **Process noise** is **Additive** — Specify the covariance as a scalar, an N_s -element vector, or an N_s -by- N_s matrix, where N_s is the number of states of the system. Specify a scalar if there is no cross-correlation between process noise terms, and all the terms have the same variance. Specify a vector of length N_s , if there is no cross-correlation between process noise terms, but all the terms have different variances.
- **Process noise** is **Nonadditive** — Specify the covariance as a W -by- W matrix, where W is the number of process noise terms in the state transition function.

Dependencies

This port is generated if you specify the process noise covariance as **Time-Varying**. The port appears when you click **Apply**.

Data Types: `single` | `double`

R1, R2, R3, R4, R5 — Time-varying measurement noise covariance

matrix

Time-varying measurement noise covariances for up to five measurement functions of the system, specified as matrices. The sizes of the matrices depend on the value of the **Measurement noise** parameter for the corresponding measurement function:

- **Measurement noise** is Additive — Specify the covariance as an N -by- N matrix, where N is the number of measurements of the system.
- **Measurement noise** is Nonadditive — Specify the covariance as a V -by- V matrix, where V is the number of measurement noise terms in the corresponding measurement function.

Dependencies

A port is generated if you specify the measurement noise covariance as **Time-Varying** for the corresponding measurement function. The port appears when you click **Apply**.

Data Types: single | double

Enable1, Enable2, Enable3, Enable4, Enable5 — Enable correction of estimated states when measured data is available

scalar

Suppose that measured output data is not available at all time points at the port **y1** that corresponds to the first measurement function. Use a signal value other than 0 at the **Enable1** port to enable the correction of estimated states when measured data is available. Specify the port value as 0 when measured data is not available. Similarly, if measured output data is not available at all time points at the port **y i** for the i^{th} measurement function, specify the corresponding port **Enable i** as a value other than 0.

Dependencies

A port corresponding to a measurement function is generated if you select **Add Enable port** for that measurement function. The port appears when you click **Apply**.

Data Types: single | double | Boolean

Output**xhat — Estimated states**

vector

Estimated states, returned as a vector of size N_s , where N_s is the number of states of the system. To access the individual states, use the Selector block.

When the **Use the current measurements to improve state estimates** parameter is selected, the block outputs the corrected state estimate $\hat{x}[k|k]$ at time step k , estimated using measured outputs until time k . If you clear this parameter, the block returns the predicted state estimate $\hat{x}[k|k-1]$ for time k , estimated using measured output until a previous time $k-1$. Clear this parameter if your filter is in a feedback loop and there is an algebraic loop in your Simulink model.

Data Types: single | double

P — State estimation error covariance

matrix

State estimation error covariance, returned as an N_s -by- N_s matrix, where N_s is the number of states of the system. To access the individual covariances, use the Selector block.

Dependencies

This port is generated if you select **Output state estimation error covariance** in the **System Model** tab, and click **Apply**.

Data Types: `single` | `double`

Parameters

System Model Tab

State Transition

Function — State transition function name

`myStateTransitionFcn` (default) | function name

The state transition function calculates the N_s -element state vector of the system at time step $k+1$, given the state vector at time step k . N_s is the number of states of the nonlinear system. You create the state transition function and specify the function name in **Function**. For example, if `vdpStateFcn.m` is the state transition function that you created and saved, specify **Function** as `vdpStateFcn`.

The inputs to the function you create depend on whether you specify the process noise as additive or nonadditive in **Process noise**.

- **Process noise** is **Additive** — The state transition function f specifies how the states evolve as a function of state values at previous time step:

$$x(k+1) = f(x(k), Us1(k), \dots, Usn(k)),$$

where $x(k)$ is the estimated state at time k , and $Us1, \dots, Usn$ are any additional input arguments required by your state transition function, such as system inputs or the sample time. To see an example of a state transition function with additive process noise, type `edit vdpStateFcn` at the command line.

- **Process noise** is **Nonadditive** — The state transition function also specifies how the states evolve as a function of the process noise w :

$$x(k+1) = f(x(k), w(k), Us1(k), \dots, Usn(k)).$$

For more information, see “State Transition and Measurement Functions” on page 3-46.

You can create f using a Simulink Function block or as a MATLAB function (.m file).

- You can use a MATLAB function only if f has one additional input argument $Us1$ other than x and w .

$$x(k+1) = f(x(k), w(k), Us1(k))$$

The software generates an additional input port **StateTransitionFcnInputs** to specify this argument.

- If you are using a Simulink Function block, specify x and w using Argument Inport blocks and the additional inputs Us_1, \dots, Us_n using Inport blocks in the Simulink Function block. You do not provide Us_1, \dots, Us_n to the Extended Kalman Filter block.

Programmatic Use**Block Parameter:** StateTransitionFcn**Type:** character vector, string**Default:** 'myStateTransitionFcn'**Jacobian — Jacobian of state transition function**

off (default) | on

Jacobian of state transition function f , specified as one of the following:

- **off** — The software computes the Jacobian numerically. This computation may increase processing time and numerical inaccuracy of the state estimation.
- **on** — You create a function to compute the Jacobian, and specify the name of the function in **Jacobian**. For example, if `vdpStateJacobianFcn.m` is the Jacobian function, specify **Jacobian** as `vdpStateJacobianFcn`. If you create the state transition function f using a Simulink Function block, then create the Jacobian using a Simulink Function block. If you create f using a MATLAB function (`.m` file), then create the Jacobian using a MATLAB function.

The function calculates the partial derivatives of the state transition function with respect to the states and process noise. The number of inputs to the Jacobian function must equal the number of inputs of the state transition function and must be specified in the same order in both functions. The number of outputs of the Jacobian function depends on the **Process noise** parameter:

- **Process noise is Additive** — The function calculates the partial derivative of the state transition function f with respect to the states ($\partial f / \partial x$). The output is an N_s -by- N_s Jacobian matrix, where N_s is the number of states.

To see an example of a Jacobian function for additive process noise, type `edit vdpStateJacobianFcn` at the command line.

- **Process noise is Nonadditive** — The function must also return a second output that is the partial derivative of the state transition function f with respect to the process noise terms ($\partial f / \partial w$). The second output is returned as an N_s -by- W matrix, where W is the number of process noise terms in the state transition function.

Programmatic Use**Block Parameter:** HasStateTransitionJacobianFcn**Type:** character vector**Values:** 'off', 'on'**Default:** 'off'**Block Parameter:** StateTransitionJacobianFcn**Type:** character vector, string**Default:** ''**Process noise — Process noise characteristics**

Additive (default) | Nonadditive

Process noise characteristics, specified as one of the following values:

- **Additive** — Process noise w is additive, and the state transition function f that you specify in **Function** has the following form:

$$x(k+1) = f(x(k), Us1(k), \dots, Usn(k)),$$

where $x(k)$ is the estimated state at time k , and $Us1, \dots, Usn$ are any additional input arguments required by your state transition function.

- **Nonadditive** — Process noise is nonadditive, and the state transition function specifies how the states evolve as a function of the state *and* process noise at the previous time step:

$$x(k+1) = f(x(k), w(k), Us1(k), \dots, Usn(k)).$$

Programmatic Use

Block Parameter: HasAdditiveProcessNoise

Type: character vector

Values: 'Additive', 'Nonadditive'

Default: 'Additive'

Covariance — Time-invariant process noise covariance

1 (default) | scalar | vector | matrix

Time-invariant process noise covariance, specified as a scalar, vector, or matrix depending on the value of the **Process noise** parameter:

- **Process noise** is **Additive** — Specify the covariance as a scalar, an Ns -element vector, or an Ns -by- Ns matrix, where Ns is the number of states of the system. Specify a scalar if there is no cross-correlation between process noise terms and all the terms have the same variance. Specify a vector of length Ns , if there is no cross-correlation between process noise terms but all the terms have different variances.
- **Process noise** is **Nonadditive** — Specify the covariance as a W -by- W matrix, where W is the number of process noise terms.

If the process noise covariance is time-varying, select **Time-varying**. The block generates input port **Q** to specify the time-varying covariance.

Dependencies

This parameter is enabled if you do not specify the process noise as **Time-Varying**.

Programmatic Use

Block Parameter: ProcessNoise

Type: character vector, string

Default: '1'

Time-varying — Time-varying process noise covariance

'off' (default) | 'on'

If you select this parameter, the block includes an additional input port **Q** to specify the time-varying process noise covariance.

Programmatic Use

Block Parameter: HasTimeVaryingProcessNoise

Type: character vector

Values: 'off', 'on'

Default: 'off'

Initialization**Initial state — Initial state estimate**

0 (default) | vector

Initial state estimate value, specified as an N_s -element vector, where N_s is the number of states in the system. Specify the initial state values based on your knowledge of the system.

Programmatic Use**Block Parameter:** InitialState**Type:** character vector, string**Default:** '0'**Initial covariance — State estimation error covariance**

1 (default) | scalar | vector | matrix

State estimation error covariance, specified as a scalar, an N_s -element vector, or an N_s -by- N_s matrix, where N_s is the number of states of the system. If you specify a scalar or vector, the software creates an N_s -by- N_s diagonal matrix with the scalar or vector elements on the diagonal.

Specify a high value for the covariance when you do not have confidence in the initial state values that you specify in **Initial state**.

Programmatic Use**Block Parameter:** InitialStateCovariance**Type:** character vector, string**Default:** '1'**Measurement****Function — Measurement function name**

myMeasurementFcn (default) | function name

The measurement function calculates the N -element output measurement vector of the nonlinear system at time step k , given the state vector at time step k . You create the measurement function and specify the function name in **Function**. For example, if `vdpMeasurementFcn.m` is the measurement function that you created and saved, specify **Function** as `vdpMeasurementFcn`.

The inputs to the function you create depend on whether you specify the measurement noise as additive or nonadditive in **Measurement noise**.

- **Measurement noise** is **Additive** — The measurement function h specifies how the measurements evolve as a function of state Values:

$$y(k) = h(x(k), Um1(k), \dots, Umn(k)),$$

where $y(k)$ and $x(k)$ are the estimated output and estimated state at time k , and $Um1, \dots, Umn$ are any optional input arguments required by your measurement function. For example, if you are using a sensor for tracking an object, an additional input could be the sensor position.

To see an example of a measurement function with additive process noise, type `edit vdpMeasurementFcn` at the command line.

- **Measurement noise** is **Nonadditive**— The measurement function also specifies how the output measurement evolves as a function of the measurement noise v :

$$y(k) = h(x(k), v(k), Um1(k), \dots, Umn(k)).$$

To see an example of a measurement function with nonadditive process noise, type `edit vdpMeasurementNonAdditiveNoiseFcn`.

For more information, see “State Transition and Measurement Functions” on page 3-46.

You can create h using a Simulink Function block or as a MATLAB function (.m file).

- You can use a MATLAB function only if h has one additional input argument $Um1$ other than x and v .

$$y[k] = h(x[k], v[k], Um1(k))$$

The software generates an additional input port **MeasurementFcn*i*Inputs** to specify this argument for the i th measurement function.

- If you are using a Simulink Function block, specify x and v using Argument Inport blocks and the additional inputs $Um1, \dots, Umn$ using Inport blocks in the Simulink Function block. You do not provide $Um1, \dots, Umn$ to the Extended Kalman Filter block.

If you have multiple sensors in your system, you can specify multiple measurement functions. You can specify up to five measurement functions using the **Add Measurement** button. To remove measurement functions, use **Remove Measurement**.

Programmatic Use

Block Parameter: MeasurementFcn1, MeasurementFcn2, MeasurementFcn3, MeasurementFcn4, MeasurementFcn5

Type: character vector, string

Default: 'myMeasurementFcn'

Jacobian — Jacobian of measurement function

off (default) | on

Jacobian of measurement function h , specified as one of the following:

- off** — The software computes the Jacobian numerically. This computation may increase processing time and numerical inaccuracy of the state estimation.
- on** — You create a function to compute the Jacobian of the measurement function h , and specify the name of the function in **Jacobian**. For example, if `vdpMeasurementJacobianFcn.m` is the Jacobian function, specify `MeasurementJacobianFcn` as `vdpMeasurementJacobianFcn`. If you create h using a Simulink Function block, then create the Jacobian using a Simulink Function block. If you create h using a MATLAB function (.m file), then create the Jacobian using a MATLAB function.

The function calculates the partial derivatives of the measurement function h with respect to the states and measurement noise. The number of inputs to the Jacobian function must equal the number of inputs to the measurement function and must be specified in the same order in both functions. The number of outputs of the Jacobian function depends on the **Measurement noise** parameter:

- Measurement noise** is **Additive** — The function calculates the partial derivatives of the measurement function with respect to the states ($\partial h / \partial x$). The output is as an N -by- N_s Jacobian matrix, where N is the number of measurements of the system and N_s is the number of states.

To see an example of a Jacobian function for additive measurement noise, type `edit vdpMeasurementJacobianFcn` at the command line.

- **Measurement noise** is *Nonadditive* — The function also returns a second output that is the partial derivative of the measurement function with respect to the measurement noise terms ($\partial h / \partial v$). The second output is returned as an N -by- V Jacobian matrix, where V is the number of measurement noise terms.

Programmatic Use

Block Parameter: HasMeasurementJacobianFcn1, HasMeasurementJacobianFcn2, HasMeasurementJacobianFcn3, HasMeasurementJacobianFcn4, HasMeasurementJacobianFcn5

Type: character vector

Values: 'off', 'on'

Default: 'off'

Block Parameter: MeasurementJacobianFcn1, MeasurementJacobianFcn2, MeasurementJacobianFcn3, MeasurementJacobianFcn4, MeasurementJacobianFcn5

Type: character vector

Default: ''

Measurement noise — Measurement noise characteristics

Additive (default) | Nonadditive

Measurement noise characteristics, specified as one of the following values:

- *Additive* — Measurement noise v is additive, and the measurement function h that you specify in **Function** has the following form:

$$y(k) = h(x(k), Um1(k), \dots, Umn(k)),$$

where $y(k)$ and $x(k)$ are the estimated output and estimated state at time k , and $Um1, \dots, Umn$ are any optional input arguments required by your measurement function.

- *Nonadditive* — Measurement noise is nonadditive, and the measurement function specifies how the output measurement evolves as a function of the state *and* measurement noise:

$$y(k) = h(x(k), v(k), Um1(k), \dots, Umn(k)).$$

Programmatic Use

Block Parameter: HasAdditiveMeasurementNoise1, HasAdditiveMeasurementNoise2, HasAdditiveMeasurementNoise3, HasAdditiveMeasurementNoise4, HasAdditiveMeasurementNoise5

Type: character vector

Values: 'Additive', 'Nonadditive'

Default: 'Additive'

Has measurement wrapping — Enable measurement wrapping

off (default) | on

Select this parameter to enable measurement wrapping to estimate states when you have circular measurements that are independent of your model states. If you select this parameter, then the measurement function you specify must include the following two outputs:

- 1 The measurement, specified as a N -element output measurement vector of the nonlinear system at time step k , given the state vector at time step k . N is the number of measurements of the system.

- 2 The measurement wrapping bounds, specified as an N -by-2 matrix where, the first column provides the minimum measurement bound and the second column provides the maximum measurement bound.

Enabling the **Has measurement wrapping** check box wraps the measurement residuals in a defined bound, which helps to prevent the filter from divergence due to incorrect measurement residual values. For an example, see “State Estimation with Wrapped Measurements Using Extended Kalman Filter”.

Programmatic Use

Block Parameter: HasMeasurementWrapping1, HasMeasurementWrapping2, HasMeasurementWrapping3, HasMeasurementWrapping4, HasMeasurementWrapping5

Type: character vector

Values: 'off', 'on'

Default: 'off'

Covariance — Time-invariant process noise covariance

1 (default) | scalar | vector | matrix

Time-invariant process noise covariance, specified as a scalar, vector, or matrix depending on the value of the **Process noise** parameter:

- **Process noise** is **Additive** — Specify the covariance as a scalar, an N_s -element vector, or an N_s -by- N_s matrix, where N_s is the number of states of the system. Specify a scalar if there is no cross-correlation between process noise terms and all the terms have the same variance. Specify a vector of length N_s , if there is no cross-correlation between process noise terms but all the terms have different variances.
- **Process noise** is **Nonadditive** — Specify the covariance as a W -by- W matrix, where W is the number of process noise terms.

If the process noise covariance is time-varying, select **Time-varying**. The block generates input port **Q** to specify the time-varying covariance.

Dependencies

This parameter is enabled if you do not specify the process noise as **Time-Varying**.

Programmatic Use

Block Parameter: ProcessNoise

Type: character vector, string

Default: '1'

Time-varying — Time-varying measurement noise covariance

off (default) | on

If you select this parameter for the measurement noise covariance of the first measurement function, the block includes an additional input port **R1**. You specify the time-varying measurement noise covariance in **R1**. Similarly, if you select **Time-varying** for the i^{th} measurement function, the block includes an additional input port **Ri** to specify the time-varying measurement noise covariance for that function.

Programmatic Use

Block Parameter: HasTimeVaryingMeasurementNoise1, HasTimeVaryingMeasurementNoise2, HasTimeVaryingMeasurementNoise3, HasTimeVaryingMeasurementNoise4, HasTimeVaryingMeasurementNoise5

Type: character vector

Values: 'off', 'on'

Default: 'off'

Add Enable Port — Enable correction of estimated states only when measured data is available

off (default) | on

Suppose that measured output data is not available at all time points at the port **y1** that corresponds to the first measurement function. Select **Add Enable port** to generate an input port **Enable1**. Use a signal at this port to enable the correction of estimated states only when measured data is available. Similarly, if measured output data is not available at all time points at the port **yi** for the i^{th} measurement function, select the corresponding **Add Enable port**.

Programmatic Use

Block Parameter: HasMeasurementEnablePort1, HasMeasurementEnablePort2, HasMeasurementEnablePort3, HasMeasurementEnablePort4, HasMeasurementEnablePort5

Type: character vector

Values: 'off', 'on'

Default: 'off'

Settings

Use the current measurements to improve state estimates — Choose between corrected or predicted state estimate

on (default) | off

When this parameter is selected, the block outputs the corrected state estimate $\hat{x}[k|k]$ at time step k , estimated using measured outputs until time k . If you clear this parameter, the block returns the predicted state estimate $\hat{x}[k|k-1]$ for time k , estimated using measured output until a previous time $k-1$. Clear this parameter if your filter is in a feedback loop and there is an algebraic loop in your Simulink model.

Programmatic Use

Block Parameter: UseCurrentEstimator

Type: character vector

Values: 'off', 'on'

Default: 'on'

Output state estimation error covariance — Output state estimation error covariance

off (default) | on

If you select this parameter, a state estimation error covariance output port **P** is generated in the block.

Programmatic Use

Block Parameter: OutputStateCovariance

Type: character vector

Values: 'off', 'on'

Default: 'off'

Data type — Data type for block parameters

double (default) | single

Use this parameter to specify the data type for all block parameters.

Programmatic Use**Block Parameter:** DataType**Type:** character vector**Values:** 'single', 'double'**Default:** 'double'**Sample time — Block sample time**

1 (default) | positive scalar

Block sample time, specified as a positive scalar. If the sample times of your state transition and measurement functions are different, select **Enable multirate operation** in the **Multirate** tab, and specify the sample times in the **Multirate** tab instead.

Dependencies

This parameter is available if in the **Multirate** tab, the **Enable multirate operation** parameter is off.

Programmatic Use**Block Parameter:** SampleTime**Type:** character vector, string**Default:** '1'**Multirate Tab****Enable multirate operation — Enable specification of different sample times for state transition and measurement functions**

off (default) | on

Select this parameter if the sample times of the state transition and measurement functions are different. You specify the sample times in the **Multirate** tab, in **Sample time**.

Programmatic Use**Block Parameter:** EnableMultirate**Type:** character vector**Values:** 'off', 'on'**Default:** 'off'**Sample times — State transition and measurement function sample times**

positive scalar

If the sample times for state transition and measurement functions are different, specify **Sample time**. Specify the sample times for the measurement functions as positive integer multiples of the state transition sample time. The sample times you specify correspond to the following input ports:

- Ports corresponding to state transition function — Additional input to state transition function **StateTransitionFcnInputs** and time-varying process noise covariance **Q**. The sample times of these ports must always equal the state transition function sample time, but can differ from the sample time of the measurement functions.
- Ports corresponding to i^{th} measurement function — Measured output **y_i**, additional input to measurement function **MeasurementFcnInputs**, enable signal at port **Enable_i**, and time-varying measurement noise covariance **R_i**. The sample times of these ports for the same measurement function must always be the same, but can differ from the sample time for the state transition function and other measurement functions.

Dependencies

This parameter is available if in the **Multirate** tab, the **Enable multirate operation** parameter is on.

Programmatic Use

Block Parameter: StateTransitionFcnSampleTime, MeasurementFcn1SampleTime1, MeasurementFcn1SampleTime2, MeasurementFcn1SampleTime3, MeasurementFcn1SampleTime4, MeasurementFcn1SampleTime5

Type: character vector, string

Default: '1'

More About

State Transition and Measurement Functions

The algorithm computes the state estimates \hat{x} of the nonlinear system using state transition and measurement functions specified by you. You can specify up to five measurement functions, each corresponding to a sensor in the system. The software lets you specify the noise in these functions as additive or nonadditive.

- **Additive Noise Terms** — The state transition and measurements equations have the following form:

$$x[k + 1] = f(x[k], u_s[k]) + w[k]$$

$$y[k] = h(x[k], u_m[k]) + v[k]$$

Here f is a nonlinear state transition function that describes the evolution of states x from one time step to the next. The nonlinear measurement function h relates x to the measurements y at time step k . w and v are the zero-mean, uncorrelated process and measurement noises, respectively. These functions can also have additional optional input arguments that are denoted by u_s and u_m in the equations. For example, the additional arguments could be time step k or the inputs u to the nonlinear system. There can be multiple such arguments.

Note that the noise terms in both equations are additive. That is, $x(k+1)$ is linearly related to the process noise $w(k)$, and $y(k)$ is linearly related to the measurement noise $v(k)$. For additive noise terms, you do not need to specify the noise terms in the state transition and measurement functions. The software adds the terms to the output of the functions.

- **Nonadditive Noise Terms** — The software also supports more complex state transition and measurement functions where the state $x[k]$ and measurement $y[k]$ are nonlinear functions of the process noise and measurement noise, respectively. When the noise terms are nonadditive, the state transition and measurements equation have the following form:

$$x[k + 1] = f(x[k], w[k], u_s[k])$$

$$y[k] = h(x[k], v[k], u_m[k])$$

Version History

Introduced in R2017a

Numerical Changes

Behavior changed in R2020b

Starting in R2020b, numerical improvements in the Extended Kalman Filter algorithm might produce results that are different from the results you obtained in previous versions.

Extended Capabilities

C/C++ Code Generation

Generate C and C++ code using Simulink® Coder™.

The state transition, measurement, and Jacobian functions that you specify must use only the MATLAB commands and Simulink blocks that support code generation. For a list of blocks that support code generation, see “Simulink Built-In Blocks That Support Code Generation” (Simulink Coder). For a list of commands that support code generation, see “Functions and Objects Supported for C/C++ Code Generation” (MATLAB Coder).

Generated code uses an algorithm that is different from the algorithm that the Extended Kalman Filter block itself uses. You might see some numerical differences in the results obtained using the two methods.

See Also

Blocks

Kalman Filter | Unscented Kalman Filter | Particle Filter

Functions

`extendedKalmanFilter` | `unscentedKalmanFilter` | `kalman` | `kalmd` | `particleFilter`

Topics

“Extended and Unscented Kalman Filter Algorithms for Online State Estimation”

“Validate Online State Estimation in Simulink”

“Troubleshoot Online State Estimation”

External Websites

Understanding Kalman Filters: Nonlinear State Estimators — MATLAB Video Series

LTI System

Use linear time invariant system model object in Simulink

Library: Control System Toolbox

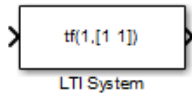

Description

The LTI System block imports linear system model objects into the Simulink environment. You specify the LTI model to import in the **LTI system variable** parameter. You can import any type of proper linear time-invariant dynamic system model. If the imported system is a state-space (SS) model, you can specify initial state values in the **Initial states** parameter.

Ports

Input

Port_1(In1) — Input signal

scalar | vector

For a single-input LTI system, the input signal is a scalar. For multiple-input systems, combine the system inputs into a vector signal, using blocks such as:

- Mux
- Vector Concatenate
- Bus Creator

Output

Port_1(Out1) — Output signal

scalar | vector

For a single-output LTI system, the output signal is a scalar. For multiple-output systems, the output signal is a vector. To split system outputs into scalar signals, use blocks such as:

- Demux
- Bus Selector

Parameters

LTI system variable — Linear system

dynamic system model

Specify the linear system for the block as a MATLAB expression or a variable in the MATLAB workspace, the model workspace, or a data dictionary. The model can be SISO or MIMO.

Most linear time-invariant dynamic system models are supported, except:

- Frequency-response data models, such as `frd` and `genfrd` models.
- Nonlinear identified models, such as `idnlarx`.
- Models with unmodeled dynamics, such as `udyn`.

The specified model must be proper (see `isproper`).

The model can be either continuous time or discrete time. When the LTI system block is in a Simulink model with synchronous state control (see the State Control block), you must specify a discrete-time model.

Simulink converts the model to its state-space equivalent prior to initializing the simulation.

Initial states (state-space only) – Initial state values for state-space model

[] (default) | vector | scalar

If the linear system is in state-space form, specify the initial state values as a vector with as many entries as the system has states. If you specify a scalar value, the block applies that value to each state in the system. The default value, [], initializes all states to zero.

The concept of initial state is not well-defined for linear systems that are not in state-space form, such as transfer functions or zero-pole-gain models. For such models, the initial state depends on the choice of state coordinates used by the realization algorithm. As a result, the block ignores this parameter for such models.

Version History

Introduced before R2006a

Extended Capabilities

C/C++ Code Generation

Generate C and C++ code using Simulink® Coder™.

See Also

LPV System

Topics

“Import LTI Model Objects into Simulink”

LPV System

Simulate Linear Parameter-Varying (LPV) systems

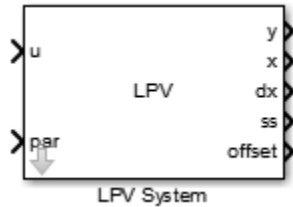

Description

Represent and simulate Linear Parameter-Varying (LPV) systems in Simulink. The block also supports code generation.

A linear parameter-varying (LPV) system is a linear state-space model whose dynamics vary as a function of certain time-varying parameters called scheduling parameters. In MATLAB, an LPV model is represented in a state-space form using coefficients that are parameter dependent.

Mathematically, an LPV system is represented as:

$$\begin{aligned} dx(t) &= A(p)x(t) + B(p)u(t) \\ y(t) &= C(p)x(t) + D(p)u(t) \\ x(0) &= x_0 \end{aligned} \tag{3-1}$$

where

- $u(t)$ are the inputs
- $y(t)$ the outputs
- $x(t)$ are the model states with initial value x_0
- $dx(t)$ is the state derivative vector \dot{x} for continuous-time systems and the state update vector $x(t + \Delta T)$ for discrete-time systems. ΔT is the sample time.
- $A(p)$, $B(p)$, $C(p)$ and $D(p)$ are the state-space matrices parameterized by the scheduling parameter vector p .
- The parameters $p = p(t)$ are measurable functions of the inputs and the states of the model. They can be a scalar quantity or a vector of several parameters. The set of scheduling parameters define the *scheduling space* over which the LPV model is defined.

The block implements a grid-based representation of the LPV system. You pick a grid of values for the scheduling parameters. At each value $p = p^*$, you specify the corresponding linear system as a state-space (ss or idss) model object. You use the generated array of state-space models to configure the LPV System block.

The block accepts an array of state-space models with operating point information. The information on the scheduling variables is extracted from the `SamplingGrid` property of the LTI array. The scheduling variables define the grid of the LPV models. They are scalar-valued quantities that can be functions of time, inputs and states, or constants. They are used to pick the local dynamics in the

operating space. The software interpolates the values of these variables. The block uses this array with data interpolation and extrapolation techniques for simulation.

The LPV system representation can be extended to allow offsets in dx , x , u and y variables. This form is known as affine form of the LPV model. Mathematically, the following represents an LPV system:

$$\begin{aligned} dx(t) &= A(p)x(t) + B(p)u(t) + (\overline{dx}(p) - A(p)\overline{x}(p) - B(p)\overline{u}(p)) \\ y(t) &= C(p)x(t) + D(p)u(t) + (\overline{y}(p) - C(p)\overline{x}(p) - D(p)\overline{u}(p)) \\ x(0) &= x_0 \end{aligned} \tag{3-2}$$

$\overline{dx}(p)$, $\overline{x}(p)$, $\overline{u}(p)$, $\overline{y}(p)$ are the offsets in the values of $dx(t)$, $x(t)$, $u(t)$ and $y(t)$ at a given parameter value $p = p(t)$.

To obtain such representations of the linear system array, linearize a Simulink model over a batch of operating points (see “Batch Linearization” (Simulink Control Design).) The offsets correspond to the operating points at which you linearized the model.

You can obtain the offsets by returning additional linearization information when calling functions such as `linearize` or `getIOTransfer`. You can then extract the offsets using `getOffsetsForLPV`. For an example, see “LPV Approximation of Boost Converter Model” (Simulink Control Design).

The following limitations apply to the LPV System block:

- Internal delays cannot be extrapolated to be less than their minimum value in the state-space model array.
- When using an irregular grid of linear models to define the LPV system, only the nearest neighbor interpolation scheme is used. This may reduce the accuracy of simulation results. It is recommended to work with regular grids. To learn more about regular and irregular grids, see “Regular vs. Irregular Grids”.

Data Type Support

Single and double data. You must convert any other data type for input signals or model properties to these data types.

Parameters

The LPV System Block Parameter dialog box contains five tabs for specifying the system data, scheduling algorithm and output ports. The following table summarizes the block parameters.

Task	Parameters
Specify an array of state-space models and initial states	In LPV Model tab: <ul style="list-style-type: none"> • State-space array on page 3-52 • Initial state on page 3-53

Task	Parameters
Specify operating point offsets	In LPV Model tab: <ul style="list-style-type: none"> • Input offset on page 3-53 • Output offset on page 3-53 • State offset on page 3-53
Specify offsets in state derivative or update variable	In the LPV Model tab: <ul style="list-style-type: none"> • State derivative/update offset on page 3-54
Specify which model matrices are fixed and their nominal values to override entries in model data. In some situations, you may want to replace a parameter-dependent matrix such as $A(p)$ with a fixed value A^* for simulation. For example, A^* may represent an average value over the scheduling range.	In the Fixed Entries tab: <ul style="list-style-type: none"> • Nominal Model on page 3-54 • Fixed Coefficient Indices on page 3-54
Specify options for interpolation and extrapolation	In the Scheduling tab: <ul style="list-style-type: none"> • Interpolation method on page 3-55 • Extrapolation method on page 3-55 • Index search method on page 3-56 • Begin index search using previous index result on page 3-56
Specify additional outputs for the block	In the Outputs tab: <ul style="list-style-type: none"> • Output states on page 3-56 • Output state derivatives (continuous-time) or updates (discrete-time) on page 3-56 • Output interpolated state-space data on page 3-56 • Output interpolated offsets on page 3-56
Specify code generation settings	In the Code Generation tab: <ul style="list-style-type: none"> • Block data type (discrete-time case only) on page 3-56 • Initial buffer size for delays on page 3-57 • Use fixed buffer size on page 3-57

State-space array

An array of state-space (`ss` or `idss`) models. All the models in the array must use the same definition of states. Use the `SamplingGrid` property of the state-space object to specify scheduling parameters for the model. See the `ss` or `idss` model reference page for more information on the `SamplingGrid` property.

When the block is in a model with synchronous state control (see the State Control block), you must specify an array of discrete-time models.

Initial state

Initial conditions to use with the local model to start the simulation, specified one of the following:

- 0 (**Default**)
- Double vector of length equal to the number of model states

Input offset

Offsets in input $u(t)$, specified as one of the following:

- 0 (**Default**) — Use when there are no input offsets ($\bar{u}(p) = 0 \quad \forall p$).
- Double vector of length equal to the number of inputs — Use when input offset is the same across the scheduling space.
- Double array of size $[nu + 1 \text{ sysArraySize}]$ — Use when offsets are present and they vary across the scheduling space. Here, nu = number of inputs, $sysArraySize$ = array size of state-space array. Use `size` to determine the array size.

You can obtain offsets during linearization and convert them to the format supported by the LPV System block. For more information, see “Approximate Nonlinear Behavior Using Array of LTI Systems” (Simulink Control Design) and `getOffsetsForLPV`.

Output offset

Offsets in output $y(t)$, specified as one of the following:

- 0 (**Default**) — Use when there are no output offsets ($\bar{y}(p) = 0 \quad \forall p$).
- Double vector of length equal to the number of outputs. Use when output offsets are the same across the scheduling space.
- Double array of size $[ny + 1 \text{ sysArraySize}]$. Use when offsets are present and they vary across the scheduling space. Here, ny = number of outputs, $sysArraySize$ = array size of state-space array. Use `size` to determine the array size.

You can obtain offsets during linearization and convert them to the format supported by the LPV System block. For more information, see “Approximate Nonlinear Behavior Using Array of LTI Systems” (Simulink Control Design) and `getOffsetsForLPV`.

State offset

Offsets in states $x(t)$, specified as one of the following:

- 0 (**Default**) — Use when there are no state offsets ($\bar{x}(p) = 0 \quad \forall p$).
- Double vector of length equal to the number of states. Use when the state offsets are the same across the scheduling space.
- Double array of size $[nx + 1 \text{ sysArraySize}]$, where nx = number of states, $sysArraySize$ = array size of state-space array. Use when offsets are present and they vary across the scheduling space. Here, nx = number of states, $sysArraySize$ = array size of state-space array. Use `size` to determine the array size.

You can obtain offsets during linearization and convert them to the format supported by the LPV System block. For more information, see “Approximate Nonlinear Behavior Using Array of LTI Systems” (Simulink Control Design) and `getOffsetsForLPV`.

State derivative/update offset

Offsets in state derivative or update variable $dx(t)$, specified as one of the following:

- If you obtained the linear system array by linearization under equilibrium conditions, select the **Assume equilibrium operating conditions** option. This option corresponds to an offset of $\overline{dx}(p) = 0$ for a continuous-time system and $\overline{dx}(p) = \bar{x}(p)$ for a discrete-time system. This option is selected by default.
- If the linear system contains at least one system that you obtained under non-equilibrium conditions, clear the **Assume equilibrium operating conditions** option. Specify one of the following in the **Offset value** field:
 - If the dx offset values are the same across the scheduling space, specify as a double vector of length equal to the number of states.
 - If the dx offsets are present and they vary across the scheduling space, specify as a double array of size $[nx \times 1 \text{ sysArraySize}]$, where nx = number of states, and sysArraySize = array size of state-space array.

You can obtain offsets during linearization and convert them to the format supported by the LPV System block. For more information, see “Approximate Nonlinear Behavior Using Array of LTI Systems” (Simulink Control Design) and `getOffsetsForLPV`.

Nominal Model

State-space model that provides the values of the fixed coefficients, specified as one of the following:

- Use the first model in state-space array (**Default:**) — The first model in the state-space array is used to represent the LPV model. In the following example, the state-space array is specified by object `sys` and the fixed coefficients are taken from model `sys(:, :, 1)`.

```
% Specify a 4-by-5 array of state-space models.
sys = rss(4,2,3,4,5);
a = 1:4;
b = 10:10:50;
[av,bv] = ndgrid(a,b);
% Use "alpha" and "beta" variables as scheduling parameters.
sys.SamplingGrid = struct('alpha',av,'beta',bv);
```

Fixed coefficients are taken from the model `sysFixed = sys(:, :, 1)`, which corresponds to `[alpha=1, beta=10]`. If the (2,1) entry of A matrix is forced to be fixed, its value used during the simulation is `sysFixed.A(2,1)`.

- Custom value — Specify a different state-space model for fixed entries. Specify a variable for the fixed model in the **State space model** field. The fixed model must use the same state basis as the state-space array in the LPV model.

Fixed Coefficient Indices

Specify which coefficients of the state-space matrices and delay vectors are fixed.

Specify one of the following:

- Scalar Boolean (`true` or `false`), if all entries of a matrix are to be treated the same way.

The default value is `false` for the state-space matrices and delay vectors, which means that they are treated as free.

- Logical matrix of a size compatible with the size of the corresponding matrix:

State-space matrix	Size of fixed entry matrix
A matrix	n_x -by- n_x
B matrix	n_x -by- n_u
C matrix	n_y -by- n_x
D matrix	n_y -by- n_u
Input delay	n_u -by-1
Output delay	n_y -by-1
Internal delay	n_i -by-1

where, n_u = number of inputs, n_y = number of outputs, n_x = number of states, n_i = length of internal delay vector.

- Numerical indices to specify the location of fixed entries. See `sub2ind` reference page for more information on how to generate numerical indices corresponding to a given subscript (i, j) for an element of a matrix.

Interpolation method

Interpolation method. Defines how the state-space data must be computed for scheduling parameter values that are located away from their grid locations.

Specify one of the following options:

- **Flat** — Choose the state-space data at the grid point closest, but not larger than, the current point. The *current point* is the value of the scheduling parameters at current time.
- **Nearest** — Choose the state-space data at the closest grid point in the scheduling space.
- **Linear** — Obtain state-space data by linear interpolation of the nearest 2d neighbors in the scheduling space, where d = number of scheduling parameters.

The default interpolation scheme is **Linear** for regular grids of scheduling parameter values. For irregular grids, the **Nearest** interpolation scheme is always used regardless of the choice made. to learn more about regular and irregular grids, see “Regular vs. Irregular Grids”.

The **Linear** method provides the highest accuracy but takes longer to compute. The **Flat** and **Nearest** methods are good for models that have mode-switching dynamics.

Extrapolation method

Extrapolation method. Defines how to compute the state-space data for scheduling parameter values that fall outside the range over which the state-space array has been provided (as specified in the `SamplingGrid` property).

Specify one of the following options:

- **Clip (Default:)** — Disables extrapolation and returns the data corresponding to the last available scheduling grid point that is closest to the current point.

- **Linear** — Fits a line between the first or last pair of values for each scheduling parameter, depending upon whether the current value is less than the first or greater than the last grid point value, respectively. This method returns the point on that line corresponding to the current value. Linear extrapolation requires that the interpolation scheme be linear too.

Index search method

The location of the current scheduling parameter values in the scheduling space is determined by a prelookup algorithm. Select **Linear search** or **Binary search**. Each search method has speed advantages in different situations. For more information on this parameter, see the Prelookup (Simulink) block reference page.

Begin index search using previous index result

Select this check box when you want the block to start its search using the index found at the previous time step. For more information on this parameter, see the Prelookup (Simulink) block reference page.

Output states

Add **x** port to the block to output state values. This option is selected by default.

Output state derivatives (continuous-time) or updates (discrete-time)

Add **dx** port to the block to output state derivative values or update the values. This option is selected by default.

Output interpolated state-space data

Add **ss** port to the block to output state-space data as a structure. This option is selected by default.

The fields of the generated structure are:

- State-space matrices **A**, **B**, **C**, **D**.
- Delays **InputDelay**, **OutputDelay**, and **InternalDelay**. The **InternalDelay** field is available only when the model has internal delay.

Output interpolated offsets

Add **offset** port to the block to output LPV model offsets $(\bar{u}(p), \bar{y}(p), \bar{x}(p), \overline{dx}(p))$.

The fields of the structure are:

- **InputOffset**, **OutputOffset**, **StateOffset**, and **StateDerivativeOffset** in continuous-time.
- **InputOffset**, **OutputOffset**, **StateOffset**, and **StateUpdateOffset** in discrete-time.

Block data type (discrete-time case only)

Supported data type. Use this option only for discrete-time state-space models. Specify **double** or **single**.

Initial buffer size for delays

Initial memory allocation for the number of input points to store for models that contain delays. If the number of input points exceeds the initial buffer size, the block allocates additional memory. The default size is 1024.

When you run the model in Accelerator mode or build the model, make sure the initial buffer size is large enough to handle maximum anticipated delay in the model.

Use fixed buffer size

Specify whether to use a fixed buffer size to save delayed input and output data from previous time steps. Use this option for continuous-time LPV systems that contain input or output delays. If the buffer is full, new data replaces data already in the buffer. The software uses linear extrapolation to estimate output values that are not in the buffer.

Examples

Configure the Scheduling Parameter Input Port

Consider a 2-input, 3-output, 4-state LPV model. Use input $u(2)$ and state $x(1)$ as scheduling parameters. Configure the Simulink model as shown in the following figure.

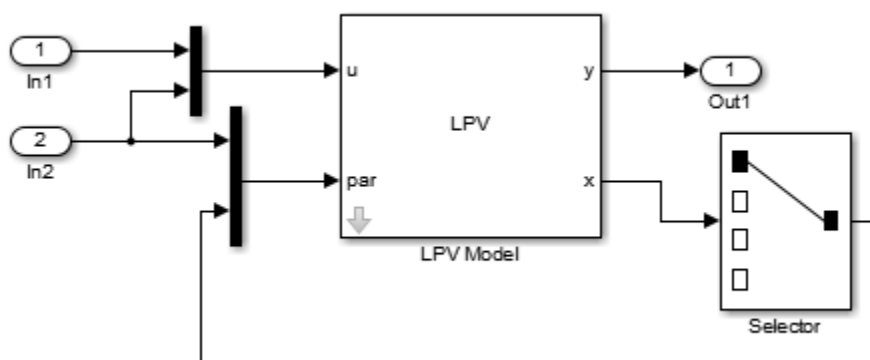

Simulate a Linear Parameter-Varying System

Consider a linear mass-spring-damper system whose mass changes as a function of an external load command. The governing equation is:

$$m(u)\ddot{y} + c\dot{y} + k(y)y = F(t)$$

where $m(u)$ is the mass dependent upon the external command u , c is the damping ratio, k is the stiffness of the spring and $F(t)$ is the forcing input. $y(t)$ is position of the mass at a given time t . For a fixed value of u , the system is linear and expressed as:

$$A = \begin{bmatrix} 0 & 1 \\ -\frac{k}{m} & -\frac{c}{m} \end{bmatrix}, \quad B = \begin{bmatrix} 0 \\ \frac{1}{m} \end{bmatrix}, \quad C = [1 \ 0]$$

$$\dot{x} = Ax + Bu, \quad y = Cx$$

where $x = \begin{bmatrix} y \\ \dot{y} \end{bmatrix}$ is the state vector and m is the value of the mass for a given value of u .

In this example, you want to study the model behavior over a range of input values from 1 to 10 Volts. For each value of u , measure the mass and compute the linear representation of the system. Suppose, mass is related to the input by the relationship: $m(u) = 10u + 0.1u^2$. For values of u ranging from 1:10 results in the following array of linear systems.

```
% Specify damping coefficient.
c = 5;
% Specify stiffness.
k = 300;
% Specify load command.
u = 1:10;
% Specify mass.
m = 10*u + 0.1*u.^2;
% Compute linear system at a given mass value.
for i = 1:length(u)
    A = [0 1; -k/m(i), -c/m(i)];
    B = [0; 1/m(i)];
    C = [1 0];
    sys(:,:,i) = ss(A,B,C,0);
end
```

The variable u is the scheduling input. Add this information to the model.

```
sys.SamplingGrid = struct('LoadCommand',u);
```

Configure the LPV System block:

- Type `sys` in the **State-space array** field.
- Connect the input port `par` to a one-dimensional source signal that generates the values of the load command. If the source provides values between 1 and 10, interpolation is used to compute the linear model at a given time instance. Otherwise, extrapolation is used.

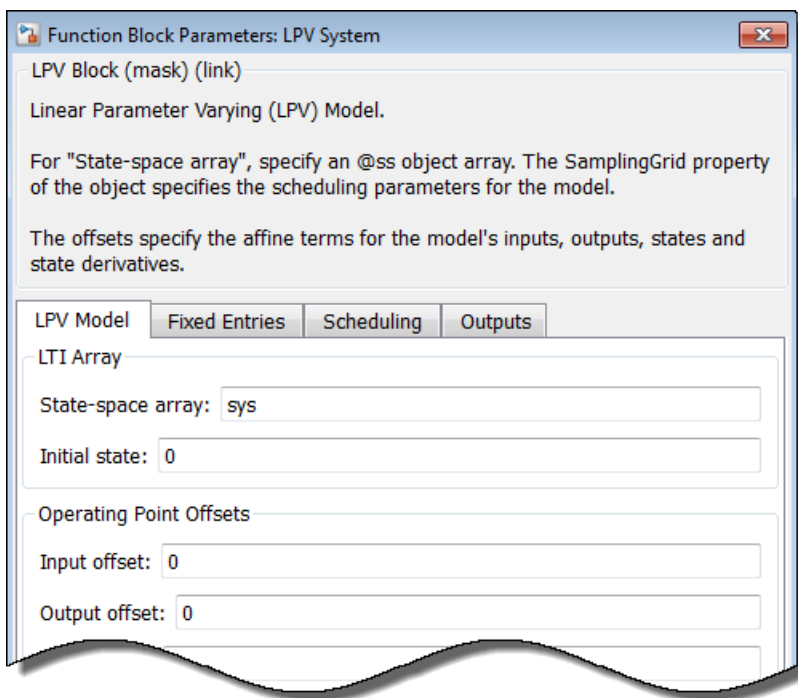

Ports

Port Name	Port Type (In/ Out)	Description
u	In	Input signal $u(t)$ in “Equation 3-2” described previously. In multi-input case, this port accepts a signal of the dimension of the input.
par	In	Provides the signals for variables defining the scheduling space (“sampling grid” variables). The scheduling variables can be functions of time, inputs and states, or constants. The required dependence can be achieved by preparing a scheduling signal using clock input (for time), input signal (u), and the outputs signals (x , dx/dt , y) of the LPV block, as required.
y	Out	Model output
x	Out	Values of the model states
xdot	Out	Values of the state derivatives. The state derivatives are sometimes used to define the scheduling parameters.
ss	Out	Local state-space model at the major simulation time steps
offset	Out	LPV model offsets

Version History

Introduced in R2014b

Extended Capabilities

C/C++ Code Generation

Generate C and C++ code using Simulink® Coder™.

See Also

getOffsetsForLPV

Topics

“Linear Parameter-Varying Models”

“Using LTI Arrays for Simulating Multi-Mode Dynamics”

“Approximate Nonlinear Behavior Using Array of LTI Systems” (Simulink Control Design)

“LPV Approximation of Boost Converter Model” (Simulink Control Design)

Particle Filter

Estimate states of discrete-time nonlinear system using particle filter

Library: Control System Toolbox / State Estimation
System Identification Toolbox / Estimators

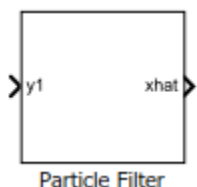

Description

The Particle Filter block estimates the states of a discrete-time nonlinear system using the discrete-time particle filter algorithm.

Consider a plant with states x , input u , output m , process noise w , and measurement y . Assume that you can represent the plant as a nonlinear system.

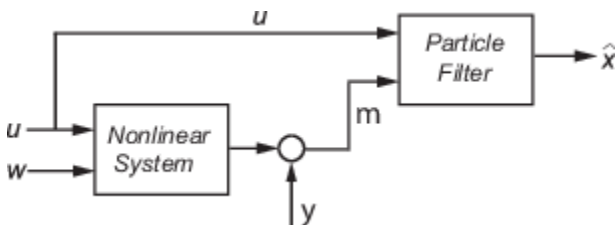

The algorithm computes the state estimates \hat{x} of the nonlinear system using the state transition and measurement likelihood functions you specify.

You create the nonlinear state transition function and measurement likelihood functions for the system and specify these functions in the block. The block supports state estimation of a system with multiple sensors that are operating at different sampling rates. You can specify up to five measurement likelihood functions, each corresponding to a sensor in the system.

Ports

Input

y1, y2, y3, y4, y5 — Measured system outputs
vector

Measured system outputs corresponding to each measurement likelihood function that you specify in the block. The number of ports equals the number of measurement likelihood functions in your system. You can specify up to five measurement likelihood functions. For example, if your system has two sensors, you specify two measurement likelihood functions in the block. The first port **y1** is available by default. Click **Add Measurement**, to generate port **y2** corresponding to the second measurement likelihood function.

Specify the ports as N -dimensional vectors, where N is the number of quantities measured by the corresponding sensor. For example, if your system has one sensor that measures the position and

velocity of an object, then there is only one port **y1**. The port is specified as a two-dimensional vector with values corresponding to position and velocity.

Dependencies

The first port **y1** is available by default. Ports **y2** to **y5** are generated when you click **Add Measurement**.

StateTransitionFcnInputs — Optional input argument to state transition function

scalar | vector | matrix

Optional input argument to the state transition function **f** other than the state **x**.

If you create **f** using a MATLAB function (.m file), the software generates the port **StateTransitionFcnInputs** when you enter the name of your function, and click **Apply**.

If your state transition function has more than one additional input, use a Simulink Function block to specify the function. When you use a Simulink Function block, you provide the additional inputs directly to the Simulink Function block using Inport blocks. No input ports are generated for the additional inputs in the Particle Filter block.

Dependencies

This port is generated only if both of the following conditions are satisfied:

- You specify **f** in **Function** using a MATLAB function, and **f** is on the MATLAB path.
- **f** requires only one additional input argument apart from particles.

MeasurementLikelihoodFcn1Inputs, . . . , MeasurementLikelihoodFcn5Inputs — Optional input argument to each measurement likelihood function

scalar | vector | matrix

Optional inputs to the measurement likelihood functions other than the state **x** and measurement **y**.

MeasurementLikelihoodFcn1Inputs corresponds to the first measurement likelihood function that you specify, and so on.

If you specify two measurement inputs using MATLAB functions (.m files) in **Function**, the software generates ports **MeasurementLikelihoodFcn1Inputs** and **MeasurementLikelihoodFcn2Inputs** when you click **Apply**. You can specify the inputs to these ports as scalars, vectors, or matrices.

If your measurement likelihood functions have more than one additional input, use Simulink Function blocks to specify the functions. When you use a Simulink Function block, you provide the additional inputs directly to the Simulink Function block using Inport blocks. No input ports are generated for the additional inputs in the Particle Filter block.

Dependencies

A port corresponding to a measurement likelihood function **h** is generated only if both of the following conditions are satisfied:

- You specify measurement input **h** in **Function** using a MATLAB function, and **h** is on the MATLAB path.
- **h** requires only one additional input argument apart from particles and measurement.

Enable1, Enable2, Enable3, Enable4, Enable5 — Enable correction of estimated states when measured data is available

scalar

Enable correction of estimated states when measured data is available.

For example, consider that measured output data is not available at all time points at the port **y1** that corresponds to the first measurement likelihood function. Then, use a signal value other than 0 at the **Enable1** port to enable the correction of estimated states when measured data is available. Specify the port value as 0 when measured data is not available. Similarly, if measured output data is not available at all time points at the port **yi** for the i^{th} measurement likelihood function, specify the corresponding port **Enablei** as a value other than 0.

Dependencies

If you select **Add Enable port** for a measurement likelihood function, a port corresponding to that measurement likelihood function is generated. The port appears when you click **Apply**.

Output

xhat — Estimated states

vector

Estimated states, returned as a vector of size N_s , where N_s is the number of states of the system. To access the individual states, use the Selector block.

When the **Use the current measurements to improve state estimates** parameter is selected, the block outputs the corrected state estimate $\hat{x}[k|k]$ at time step k , estimated using measured outputs until time k . If you clear this parameter, the block returns the predicted state estimate $\hat{x}[k|k-1]$ for time k , estimated using measured output until a previous time $k-1$. Clear this parameter if your filter is in a feedback loop and there is an algebraic loop in your Simulink model.

P — State estimation error covariance

matrix

State estimation error covariance, returned as an N_s -by- N_s matrix, where N_s is the number of states of the system. To access the individual covariances, use the Selector block.

You can output the error covariance only if you select **Output state estimation error covariance** in the **Block outputs, Multirate** tab, and click **Apply**.

Dependencies

This parameter is available if in the **Block outputs, Multirate** tab, the **State estimation method** parameter is set to 'Mean'.

Particles — Particle values used for state estimation

array

Particle values used for state estimation, returned as an N_s -by- N_p or N_p -by- N_s array. N_s is the number of states of the system, and N_p is the number of particles.

- If the **StateOrientation** parameter is specified as 'column', then **Particles** is returned as an N_s -by- N_p array.
- If the **StateOrientation** parameter is specified as 'row', then **Particles** is returned as an N_p -by- N_s array.

Dependencies

This port is generated if you select **Output all particles** in the **Block outputs, Multirate** tab, and click **Apply**.

Weights — Particle weights used for state estimation

vector

Particle weights used for state estimation, returned as a 1-by- N_p or N_p -by-1 vector, where N_p is the number of particles used for state estimation.

- If the **StateOrientation** parameter is specified as 'column', then **Weights** is returned as a 1-by- N_p vector, where each weight is associated with the particle in the same column in the **Particles** array.
- If the **StateOrientation** parameter is specified as 'row', then **Weights** is returned as a N_p -by-1 vector, where each weight is associated with the particle in the same row in the **Particles** array.

Dependencies

This port is generated if you select **Output weights** in the **Block outputs, Multirate** tab, and click **Apply**.

Parameters**System Model Tab****State Transition****Function — State transition function name**

'vdpParticleFilterStateFcn' (default) | function name

The particle filter state transition function calculates the particles at time step $k+1$, given particles at time step k per the dynamics of your system and process noise. This function has the syntax:

```
particlesNext = f(particles, param1, param2, ...)
```

where, *particles* and *particlesNext* have dimensions N_s -by- N_p if **State Orientation** is specified as 'column', or N_p -by- N_s if **State Orientation** is specified as 'row'. Also, *param_i* represents optional input arguments you may specify. For more information on optional input arguments, see "StateTransitionFcnInputs" on page 3-0 .

You create the state transition function and specify the function name in **Function**. For example, if `vdpParticleFilterStateFcn.m` is the state transition function that you created and saved, specify **Function** as 'vdpParticleFilterStateFcn'.

You can create **Function** using a Simulink Function block or as a MATLAB function (.m file).

Programmatic Use

Block Parameter: StateTransitionFcn

Type: character vector, string

Default: 'vdpParticleFilterStateFcn'

Initialization

Number of Particles — Number of particles used in the filter

1000 (default) | positive scalar integer

Number of particles used in the filter, specified as a positive scalar integer. Each particle represents a state hypothesis in the system. A higher number of particles increases the state estimation accuracy, but also increases the computational effort required to run the filter.

Programmatic Use

Block Parameter: NumberOfParticles

Type: positive scalar integer

Default: 1000

Distribution — Initial distribution of particles

'Gaussian' (default) | 'Uniform' | 'Custom'

Initial distribution of particles, specified as 'Gaussian', 'Uniform', or 'Custom'.

If you choose 'Gaussian', the initial set of particles or state hypotheses are distributed per the multivariate Gaussian distribution, where you specify the **Mean** and **Covariance**. The initial weight of all particles is assumed to be equal.

If you choose 'Uniform', the initial set of particles are distributed per the uniform distribution, where you specify the upper and lower **State bounds**. The initial weight of all particles is assumed to be equal.

'Custom' allows you to specify your own set of initial particles and their weights. You can use arbitrary probability distributions for **Particles** and **Weights** to initialize the filter.

Programmatic Use

Block Parameter: InitialDistribution

Type: character vector

Values: 'Gaussian', 'Uniform', 'Custom'

Default: 'Gaussian'

Mean — Initial mean value of particles

[0;0] (default) | vector

Initial mean value of particles, specified as a vector. The number of states to be estimated defines the length of the vector.

Dependencies

This parameter is available if in the **System model** tab, the **Distribution** parameter is set to Gaussian.

Programmatic Use

Block Parameter: InitialMean

Type: array

Default: [0,0]

Covariance — Initial covariance of particles

1 (default) | scalar | vector | matrix

Initial covariance of particles, specified as a scalar, vector, or matrix.

If **Covariance** is specified as:

- A scalar, then it must be positive. The covariance is assumed to be a $[N_s N_s]$ matrix with this scalar on the diagonals. Here, N_s is the number of states.
- A vector, then each element must be positive. The covariance is assumed to be a $[N_s N_s]$ matrix with the elements of the vector on the diagonals.
- A matrix, then it must be positive semidefinite.

Dependencies

This parameter is available if in the **System model** tab, the **Distribution** parameter is set to Gaussian.

Programmatic Use

Block Parameter: InitialCovariance

Type: scalar, vector, or matrix

Default: 1

Circular Variables — Circular variables used for state estimation

0 (default) | scalar | vector

Circular variables used for state estimation, specified as a scalar, or N_s -element vector, where N_s is the number of states.

If **Circular Variables** is specified as a scalar, the software extends it to a vector where each element is equal to this scalar. Circular (or angular) distributions use a probability density function with a range of $[-\pi \pi]$. Use circular variables if some of the states in your system represent angular quantities like the orientation of an object.

Programmatic Use

Block Parameter: CircularVariables

Type: scalar, vector

Default: 0

State Orientation — Orientation of input system states

'column' (default) | 'row'

Orientation of system states, specified as 'column' or 'row'.

If **State Orientation** is specified as:

- 'column', then the first input argument to the state transition and measurement likelihood function is $[N_s N_p]$. In this case, i^{th} column of this matrix is the i^{th} particle (state hypothesis). Also, the states estimates **xhat** is output as a $[N_s 1]$ vector. Here, N_s is the number of states, and N_p is the number of particles.
- 'row', then the first input argument to the state transition and measurement likelihood function is $[N_p N_s]$, and each row of this matrix contains a particle. Also, the states estimates **xhat** is output as a $[1 N_s]$ vector.

Programmatic Use

Block Parameter: StateOrientation

Type: character vector

Values: 'column', 'row'

Default: 'column'

State bounds — Initial bounds on system states

[-3 3;-3 3] (default) | array

Initial bounds on system states, specified as an N_s -by-2 array, where N_s is the number of states.

The i^{th} row lists the lower and upper bound of the uniform distribution for the initial distribution of particles of the i^{th} state.

Dependencies

This parameter is available if in the **System model** tab, the **Distribution** parameter is set to Uniform.

Programmatic Use**Block Parameter:** InitialStateBounds**Type:** array**Default:** [-3 3;-3 3]**Particles — Custom particle distribution for state estimation**

[] (default) | array

Custom particle distribution for state estimation, specified as an N_s -by- N_p or N_p -by- N_s array. N_s is the number of states of the system, and N_p is the number of particles.

- If the StateOrientation parameter is specified as 'column', then **Particles** is an N_s -by- N_p array.
- If the StateOrientation parameter is specified as 'row', then **Particles** is an N_p -by- N_s array.

Dependencies

This parameter is available if in the **System model** tab, the **Distribution** parameter is set to Custom.

Programmatic Use**Block Parameter:** InitialParticles**Type:** array**Default:** []**Weights — Custom particle weight values for state estimation**

[] (default) | positive vector

Custom particle weight values for state estimation, specified as a 1-by- N_p or N_p -by-1 positive vector, where N_p is the number of particles used for state estimation.

- If the StateOrientation parameter is specified as 'column', then **Weights** is a 1-by- N_p vector. Each weight in the vector is associated with the particle in the same column in the **Particles** array.
- If the StateOrientation parameter is specified as 'row', then **Weights** is a N_p -by-1 vector. Each weight in the vector is associated with the particle in the same row in the **Particles** array.

Dependencies

This parameter is available if in the **System model** tab, the **Distribution** parameter is set to Custom.

Programmatic Use**Block Parameter:** InitialWeights**Type:** positive vector**Default:** []**Measurement****Function — Measurement likelihood function name**

'vdpMeasurementLikelihoodFcn' (default) | function name

The measurement likelihood function calculates the likelihood of particles (state hypotheses) using the sensor measurements. For each state hypothesis (particle), the function first calculates an Nm -element measurement hypothesis vector. Then the likelihood of each measurement hypothesis is calculated based on the sensor measurement and the measurement noise probability distribution. This function has the syntax:

```
likelihood = h(particles, measurement, param1, param2, ...)
```

where, *likelihood* is an Np -element vector, where Np is the number of particles. *particles* have dimensions Ns -by- Np if **State Orientation** is specified as 'column', or Np -by- Ns if **State Orientation** is specified as 'row'. *measurement* is an Nm -element vector where, Nm is the number of measurements your sensor provides. *param_i* represents optional input arguments you may specify. For more information on optional input arguments, see "MeasurementLikelihoodFcn1Inputs,...,MeasurementLikelihoodFcn5Inputs" on page 3-0 .

You create the measurement likelihood function and specify the function name in **Function**. For example, if vdpMeasurementLikelihoodFcn.m is the measurement likelihood function that you created and saved, specify **Function** as 'vdpMeasurementLikelihoodFcn'.

You can create **Function** using a Simulink Function block or as a MATLAB function (.m file).

- You can use a MATLAB function only if *h* has zero or one additional input argument *param_i* other than **Particles** and **Measurement**.

The software generates an additional input port **MeasurementLikelihoodFcn*i*Inputs** to specify this argument for the i^{th} measurement likelihood function, and click **Apply**.

- If you are using a Simulink Function block, specify *x* and *y* using Argument Inport blocks and the additional inputs *param_i* using Inport blocks in the Simulink Function block. You do not provide *param_i* to the Particle Filter block.

If you have multiple sensors in your system, you can specify multiple measurement likelihood functions. You can specify up to five measurement likelihood functions using the **Add Measurement** button. To remove measurement likelihood functions, use **Remove Measurement**.

Programmatic Use**Block Parameter:** MeasurementLikelihoodFcn1, MeasurementLikelihoodFcn2, MeasurementLikelihoodFcn3, MeasurementLikelihoodFcn4, MeasurementLikelihoodFcn5**Type:** character vector, string**Default:** 'vdpMeasurementLikelihoodFcn'**Add Enable Port — Enable correction of estimated states only when measured data is available**

off (default) | on

Suppose that measured output data is not available at all time points at the port **y1** that corresponds to the first measurement likelihood function. To generate an input port **Enable1**, select **Add Enable**

port. Use a signal at this port to enable the correction of estimated states only when measured data is available. Similarly, if measured output data is not available at all time points at the port y_i for the i^{th} measurement likelihood function, select the corresponding **Add Enable port**.

Programmatic Use

Block Parameter: HasMeasurementEnablePort1, HasMeasurementEnablePort2, HasMeasurementEnablePort3, HasMeasurementEnablePort4, HasMeasurementEnablePort5

Type: character vector

Values: 'off', 'on'

Default: 'off'

Resampling

Resampling method — Method used for particle resampling

'Multinomial' (default) | 'Systemic' | 'Stratified'

Method used for particle resampling, specified as one of the following:

- 'Multinomial' — Multinomial resampling, also called simplified random sampling, generates N random numbers independently from the uniform distribution in the open interval $(0, 1)$ and uses them to select particles proportional to their weight.
- 'Stratified' — Stratified resampling divides the whole population of particles into subsets called strata. It pre-partitions the $(0, 1)$ interval into N disjoint sub-intervals of size $1/N$. The random numbers are drawn independently in each of these sub-intervals and the sample indices chosen in the strata.
- 'Systemic' — Systemic resampling is similar to stratified resampling as it also makes use of strata. One distinction is that it only draws one random number from the open interval $(0, 1/N)$ and the remaining sample points are calculated deterministically at a fixed $1/N$ step size.

Programmatic Use

Block Parameter: ResamplingMethod

Type: character vector

Values: 'Multinomial', 'Systemic', 'Stratified'

Default: 'Multinomial'

Trigger method — Method to determine when resampling occurs

'Ratio' (default) | 'Interval'

Method to determine when resampling occurs, specified as either 'Ratio' or 'Interval'. The 'Ratio' value triggers resampling based on the ratio of effective total particles. The 'Interval' value triggers resampling at regular time steps of the particle filter operation.

Programmatic Use

Block Parameter: TriggerMethod

Type: character vector

Values: 'Ratio', 'Interval'

Default: 'Ratio'

Minimum effective particle ratio — Minimum desired ratio of the effective number of particles to the total number of particles

0.5 (default) | positive scalar

Minimum desired ratio of the effective number of particles to the total number of particles, specified as a positive scalar. The effective number of particles is a measure of how well the current set of

particles approximates the posterior distribution. A lower effective particle ratio implies that a lower number of particles are contributing to the estimation and resampling is required.

If the ratio of the effective number of particles to the total number of particles falls below the minimum effective particle ratio, a resampling step is triggered.

Specify minimum effective particle ratio as any value from 0 through 1.

Dependencies

This parameter is available if in the **System model** tab, the **Trigger method** parameter is set to **Ratio**.

Programmatic Use

Block Parameter: MinEffectiveParticleRatio

Type: scalar

Values: Range [0, 1]

Default: 0.5

Sampling Interval — Fixed interval between resampling

1 (default) | positive scalar integer

Fixed interval between resampling, specified as a positive scalar integer. The sampling interval determines during which correction steps the resampling is executed. For example, a value of two means the resampling is executed every second correction step. A value of `inf` means that resampling is never executed.

Dependencies

This parameter is available if in the **System model** tab, the **Trigger method** parameter is set to **Interval**.

Programmatic Use

Block Parameter: SamplingInterval

Type: positive scalar integer

Default: 1

Random Number Generator Options

Randomness — Whether the random numbers are repeatable

'Repeatable' (default) | 'Not repeatable'

Whether the random numbers are repeatable, specified as either 'Repeatable' or 'Not repeatable'. If you want to be able to produce the same result more than once, set **Randomness** to 'Repeatable', and specify the same random number generator seed value in **Seed**.

Programmatic Use

Block Parameter: Randomness

Type: character vector

Values: 'Repeatable', 'Not repeatable'

Default: 'Repeatable'

Seed — Seed value for repeatable random numbers

0 (default) | scalar

Seed value for repeatable random numbers, specified as a scalar.

Dependencies

This parameter is available if in the **System model** tab, the **Randomness** parameter is set to 'Repeatable'.

Programmatic Use

Block Parameter: Seed

Type: scalar

Default: 0

Settings**Data type — Data type for block parameters**

double (default) | single

Use this parameter to specify the data type for all block parameters.

Programmatic Use

Block Parameter: DataType

Type: character vector

Values: 'single', 'double'

Default: 'double'

Sample time — Block sample time

1 (default) | positive scalar

Block sample time, specified as a positive scalar.

Use the **Sample time** parameter if your state transition and all measurement likelihood functions have the same sample time. Otherwise, select the **Enable multirate operation** option in the **Multirate** tab, and specify sample times in the same tab.

Dependencies

This parameter is available if in the **Block output, Multirate** tab, the **Enable multirate operation** parameter is off.

Programmatic Use

Block Parameter: SampleTime

Type: character vector, string

Default: '1'

Block Outputs, Multirate Tab**Outputs****State Estimation Method — Method used for extracting a state estimate from particles**

'Mean' (default) | 'MaxWeight' | 'None'

Method used for extracting a state estimate from particles, specified as one of the following:

- 'Mean' — The Particle Filter block outputs the weighted mean of the particles, depending on the parameters **Weights** and **Particles**, as the state estimate.
- 'Maxweight' — The Particle Filter block outputs the particle with the highest weight as the state estimate.
- 'None' — Use this option to implement a custom state estimation method by accessing all particles using the **Output all particles** parameter from the **Block outputs, Multirate** tab.

Programmatic Use**Block Parameter:** StateEstimationMethod**Type:** character vector, string**Values:** 'Mean', 'MaxWeight', 'None'**Default:** 'Mean'**Output all particles — Output all particles**

'off' (default) | 'on'

If you select this parameter, an output port for particles used in the estimation, **Particles** is generated in the block.

- If the StateOrientation parameter is specified as 'column', then the particles are output as an N_s -by- N_p array. N_s is the number of states of the system, and N_p is the number of particles.
- If the StateOrientation parameter is specified as 'row', then the particles are output as an N_p -by- N_s array.

Programmatic Use**Block Parameter:** OutputParticles**Type:** character vector**Values:** 'off', 'on'**Default:** 'off'**Output weights — Output particle weights**

'off' (default) | 'on'

If you select this parameter, an output port for particle weights used in the estimation, **Weights** is generated in the block.

- If the StateOrientation parameter is specified as 'column', then the particle weights are output as a 1-by- N_p vector. Here, where each weight is associated with the particle in the same column in the Particles array. N_p is the number of particles used for state estimation.
- If the StateOrientation parameter is specified as 'row', then the particle weights are output as a N_p -by-1 vector.

Programmatic Use**Block Parameter:** OutputWeights**Type:** character vector**Values:** 'off', 'on'**Default:** 'off'**Output state estimation error covariance — Output state estimation error covariance**

'off' (default) | 'on'

If you select this parameter, a state estimation error covariance output port, **P** is generated in the block.

Dependencies

This parameter is available if in the **Block outputs, Multirate** tab, the **State estimation method** parameter is set to 'Mean'.

Programmatic Use**Block Parameter:** OutputStateCovariance**Type:** character vector

Values: 'off', 'on'
Default: 'off'

Use the current measurements to improve state estimates — Option to use current measurements for state estimation

'on' (default) | 'off'

When this parameter is selected, the block outputs the corrected state estimate $\hat{x}[k|k]$ at time step k , estimated using measured outputs until time k . If you clear this parameter, the block returns the predicted state estimate $\hat{x}[k|k-1]$ for time k , estimated using measured output until a previous time $k-1$. Clear this parameter if your filter is in a feedback loop and there is an algebraic loop in your Simulink model.

Programmatic Use

Block Parameter: UseCurrentEstimator

Type: character vector

Values: 'on', 'off'

Default: 'on'

Multirate

Enable multirate operation — Enable specification of different sample times for state transition and measurement likelihood functions

'off' (default) | 'on'

Select this parameter if the sample times of the state transition or any of the measurement likelihood functions differ from the rest. You specify the sample times in the **Multirate** tab, in **Sample time**.

Programmatic Use

Block Parameter: EnableMultirate

Type: character vector

Values: 'off', 'on'

Default: 'off'

Sample times — State transition and measurement likelihood function sample times

positive scalar

If the sample times for state transition and measurement likelihood functions are different, specify **Sample time**. Specify the sample times for the measurement functions as positive integer multiples of the state transition sample time. The sample times you specify correspond to the following input ports:

- Ports corresponding to state transition function — Additional input to state transition function **StateTransitionFcnInputs**. The sample times of these ports must always equal the state transition function sample time, but can differ from the sample time of the measurement likelihood functions.
- Ports corresponding to i^{th} measurement likelihood function — Measured output y_i , additional input to measurement likelihood function **MeasurementLikelihoodFcn i Inputs**, enable signal at port **Enable i** . The sample times of these ports for the same measurement likelihood function must always be the same, but can differ from the sample time for the state transition function and other measurement likelihood functions.

Dependencies

This parameter is available if in the **Block outputs, Multirate** tab, the **Enable multirate operation** parameter is on.

Programmatic Use

Block Parameter: StateTransitionFcnSampleTime, MeasurementLikelihoodFcn1SampleTime1, MeasurementLikelihoodFcn1SampleTime2, MeasurementLikelihoodFcn1SampleTime3, MeasurementLikelihoodFcn1SampleTime4, MeasurementLikelihoodFcn1SampleTime5

Type: character vector, string

Default: '1'

Version History

Introduced in R2018a

References

- [1] T. Li, M. Bolic, P.M. Djuric, "Resampling Methods for Particle Filtering: Classification, implementation, and strategies," *IEEE Signal Processing Magazine*, vol. 32, no. 3, pp. 70-86, May 2015.

Extended Capabilities

C/C++ Code Generation

Generate C and C++ code using Simulink® Coder™.

The state transition and measurement likelihood functions that you specify must use only the MATLAB commands and Simulink blocks that support code generation. For a list of blocks that support code generation, see "Simulink Built-In Blocks That Support Code Generation" (Simulink Coder). For a list of commands that support code generation, see "Functions and Objects Supported for C/C++ Code Generation" (MATLAB Coder).

See Also

Blocks

Kalman Filter | Unscented Kalman Filter | Extended Kalman Filter

Functions

particleFilter | extendedKalmanFilter | unscentedKalmanFilter | kalman | kalmd

Topics

"Parameter and State Estimation in Simulink Using Particle Filter Block"

"Validate Online State Estimation in Simulink"

"Troubleshoot Online State Estimation"

"Estimate States of Nonlinear System with Multiple, Multirate Sensors"

External Websites

Understanding Kalman Filters: Nonlinear State Estimators — MATLAB Video Series

Sparse Second Order

Represent sparse second-order models in Simulink

Library: Control System Toolbox

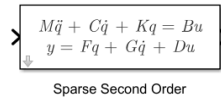

Description

The Sparse Second Order block lets you represent second-order sparse state-space models, in Simulink. Such sparse models arise from finite element analysis (FEA) and are useful in fields like structural analysis, fluid flow, heat transfer and electromagnetics. The resultant matrices from this type of modeling are quite large with a sparse pattern. In continuous time, a second-order sparse mass-spring-damper state-space model is represented in the following form:

$$\begin{aligned} M \ddot{q}(t) + C \dot{q}(t) + K q(t) &= B u(t) \\ y(t) &= F q(t) + G \dot{q}(t) + D u(t) \end{aligned}$$

Here, the full state vector is given by $[q, \dot{q}]$, where q and \dot{q} are the displacement and velocity vectors. u and y represent the inputs and outputs, respectively. M , C , and K represent the mass, damping and stiffness matrices, respectively. B is the input matrix, while F and G are the output matrices resulting from the two components of the state vector. D is the input-to-output matrix.

Ports

Input

Input 1 — Input signal

scalar | vector

Real-valued input vector of type `double` whose size is equal the number of columns in the **B** and **D** matrices.

Data Types: `double`

Output

Output 1 — Output vector

scalar | vector

Real-valued output vector of type `double` whose size is equal to the number of rows in the **F**, **G** and **D** matrices.

Data Types: `double`

Parameters

M (mass) — Mass matrix

1 (default) | scalar | Nq-by-Nq sparse matrix

Mass matrix, specified as an N_q -by- N_q sparse matrix where, N_q is the number of nodes.

Programmatic Use

Block Parameter: M

Type: scalar, square sparse matrix

Default: 1

C (damping) — Damping matrix

0 (default) | scalar | N_q -by- N_q sparse matrix

Damping matrix, specified as an N_q -by- N_q sparse matrix where, N_q is the number of nodes.

Programmatic Use

Block Parameter: C

Type: scalar, square sparse matrix

Default: 0

K (stiffness) — Stiffness matrix

1 (default) | scalar | N_q -by- N_q sparse matrix

Stiffness matrix, specified as an N_q -by- N_q sparse matrix where, N_q is the number of nodes.

Programmatic Use

Block Parameter: K

Type: scalar, square sparse matrix

Default: 1

B — Input-to-state matrix

1 (default) | scalar | N_q -by- N_u sparse matrix

Input-to-state matrix, specified as an N_q -by- N_u sparse matrix where, N_q is the number of nodes and N_u is the number of inputs.

Programmatic Use

Block Parameter: B

Type: scalar, sparse matrix

Default: 1

F — Displacement-to-output matrix

1 (default) | scalar | N_y -by- N_q sparse matrix

Displacement-to-output matrix, specified as an N_y -by- N_q sparse matrix where, N_q is the number of nodes and N_y is the number of outputs.

Programmatic Use

Block Parameter: F

Type: scalar, sparse matrix

Default: 1

G — Velocity-to-output matrix

0 (default) | scalar | N_y -by- N_q sparse matrix

Velocity-to-output matrix, specified as an N_y -by- N_q sparse matrix where, N_q is the number of nodes and N_y is the number of outputs.

Programmatic Use**Block Parameter:** G**Type:** scalar, sparse matrix**Default:** 0**D — Input-to-output matrix**

0 (default) | scalar | Ny-by-Nu sparse matrix

Input-to-output matrix, specified as an Ny-by-Nu sparse matrix where, Ny is the number of outputs and Nu is the number of inputs.

Programmatic Use**Block Parameter:** D**Type:** scalar, sparse matrix**Default:** 0**Initial position $q(0)$ — Initial values for displacement vector**

0 (default) | scalar | vector of doubles

Initial values for displacement vector q , specified as a vector of doubles. q and \dot{q} are the displacement and velocity vectors that make up the state vector.

Programmatic Use**Block Parameter:** $q0$ **Type:** scalar, vector of doubles**Default:** 0**Initial velocity $q'(0)$ — Initial values for velocity vector**

0 (default) | scalar | vector of doubles

Initial values for velocity vector \dot{q} , specified as a vector of doubles. q and \dot{q} are the displacement and velocity vectors that make up the state vector.

Programmatic Use**Block Parameter:** $dq0$ **Type:** scalar, vector of doubles**Default:** 0

Note For linearization with Simulink Control Design, the linearized model is a mechss model object when the Sparse Second Order block is present in your Simulink model.

For more information, see “Sparse Model Basics”.

For an example, see “Linearize Simulink Model to a Sparse Second-Order Model Object”.

Version History

Introduced in R2020b

Extended Capabilities

C/C++ Code Generation

Generate C and C++ code using Simulink® Coder™.

Not recommended for production code.

See Also

mechss

Topics

“Sparse Model Basics”

Unscented Kalman Filter

Estimate states of discrete-time nonlinear system using unscented Kalman filter

Library: Control System Toolbox / State Estimation
System Identification Toolbox / Estimators

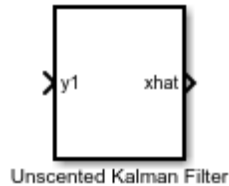

Description

The Unscented Kalman Filter block estimates the states of a discrete-time nonlinear system using the discrete-time unscented Kalman filter algorithm.

Consider a plant with states x , input u , output y , process noise w , and measurement noise v . Assume that you can represent the plant as a nonlinear system.

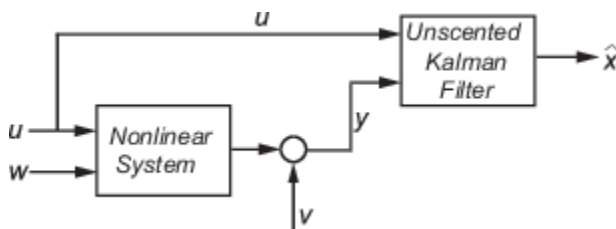

Using the state transition and measurement functions of the system and the unscented Kalman filter algorithm, the block produces state estimates \hat{x} for the current time step. For information about the algorithm, see “Extended and Unscented Kalman Filter Algorithms for Online State Estimation”.

You create the nonlinear state transition function and measurement functions for the system and specify these functions in the block. The block supports state estimation of a system with multiple sensors that are operating at different sampling rates. You can specify up to five measurement functions, each corresponding to a sensor in the system. For more information, see “State Transition and Measurement Functions” on page 3-91.

Ports

Input

y_1, y_2, y_3, y_4, y_5 – Measured system outputs
vector

Measured system outputs corresponding to each measurement function that you specify in the block. The number of ports equals the number of measurement functions in your system. You can specify up to five measurement functions. For example, if your system has two sensors, you specify two measurement functions in the block. The first port **y_1** is available by default. When you click **Apply**, the software generates port **y_2** corresponding to the second measurement function.

Specify the ports as N -dimensional vectors, where N is the number of quantities measured by the corresponding sensor. For example, if your system has one sensor that measures the position and velocity of an object, then there is only one port **y1**. The port is specified as a 2-dimensional vector with values corresponding to position and velocity.

Dependencies

The first port **y1** is available by default. Ports **y2** to **y5** are generated when you click **Add Measurement**, and click **Apply**.

Data Types: `single` | `double`

StateTransitionFcnInputs — Additional optional input argument to state transition function

scalar | vector | matrix

Additional optional input argument to the state transition function f other than the state x and process noise w . For information about state transition functions see, “State Transition and Measurement Functions” on page 3-91.

Suppose that your system has nonadditive process noise, and the state transition function f has the following form:

$$x(k+1) = f(x(k), w(k), \text{StateTransitionFcnInputs}).$$

Here k is the time step, and `StateTransitionFcnInputs` is an additional input argument other than x and w .

If you create f using a MATLAB function (`.m` file), the software generates the port **StateTransitionFcnInputs** when you click **Apply**. You can specify the inputs to this port as a scalar, vector, or matrix.

If your state transition function has more than one additional input, use a Simulink Function block to specify the function. When you use a Simulink Function block, you provide the additional inputs directly to the Simulink Function block using Inport blocks. No input ports are generated for the additional inputs in the Unscented Kalman Filter block.

Dependencies

This port is generated only if both of the following conditions are satisfied:

- You specify f in **Function** using a MATLAB function, and f is on the MATLAB path.
- f requires only one additional input argument apart from x and w .

Data Types: `single` | `double`

MeasurementFcn1Inputs, MeasurementFcn2Inputs, MeasurementFcn3Inputs, MeasurementFcn4Inputs, MeasurementFcn5Inputs — Additional optional input argument to each measurement function

scalar | vector | matrix

Additional optional inputs to the measurement functions other than the state x and measurement noise v . For information about measurement functions see, “State Transition and Measurement Functions” on page 3-91.

MeasurementFcn1Inputs corresponds to the first measurement function that you specify, and so on. For example, suppose that your system has three sensors and nonadditive measurement noise, and the three measurement functions h_1 , h_2 , and h_3 have the following form:

$$y_1[k] = h_1(x[k], v[k], \text{MeasurementFcn1Inputs})$$

$$y_2[k] = h_2(x[k], v[k], \text{MeasurementFcn2Inputs})$$

$$y_3[k] = h_3(x[k], v[k])$$

Here k is the time step, and **MeasurementFcn1Inputs** and **MeasurementFcn2Inputs** are the additional input arguments to h_1 and h_2 .

If you specify h_1 , h_2 , and h_3 using MATLAB functions (.m files) in **Function**, the software generates ports **MeasurementFcn1Inputs** and **MeasurementFcn2Inputs** when you click **Apply**. You can specify the inputs to these ports as scalars, vectors, or matrices.

If your measurement functions have more than one additional input, use Simulink Function blocks to specify the functions. When you use a Simulink Function block, you provide the additional inputs directly to the Simulink Function block using Inport blocks. No input ports are generated for the additional inputs in the Unscented Kalman Filter block.

Dependencies

A port corresponding to a measurement function h is generated only if both of the following conditions are satisfied:

- You specify h in **Function** using a MATLAB function, and h is on the MATLAB path.
- h requires only one additional input argument apart from x and v .

Data Types: `single` | `double`

Q — Time-varying process noise covariance

`scalar` | `vector` | `matrix`

Time-varying process noise covariance, specified as a scalar, vector, or matrix depending on the value of the **Process noise** parameter:

- **Process noise** is **Additive** — Specify the covariance as a scalar, an N_s -element vector, or an N_s -by- N_s matrix, where N_s is the number of states of the system. Specify a scalar if there is no cross-correlation between process noise terms, and all the terms have the same variance. Specify a vector of length N_s , if there is no cross-correlation between process noise terms, but all the terms have different variances.
- **Process noise** is **Nonadditive** — Specify the covariance as a W -by- W matrix, where W is the number of process noise terms in the state transition function.

Dependencies

This port is generated if you specify the process noise covariance as **Time-Varying**. The port appears when you click **Apply**.

Data Types: `single` | `double`

R1, R2, R3, R4, R5 — Time-varying measurement noise covariance

`matrix`

Time-varying measurement noise covariances for up to five measurement functions of the system, specified as matrices. The sizes of the matrices depend on the value of the **Measurement noise** parameter for the corresponding measurement function:

- **Measurement noise** is **Additive** — Specify the covariance as an N -by- N matrix, where N is the number of measurements of the system.
- **Measurement noise** is **Nonadditive** — Specify the covariance as a V -by- V matrix, where V is the number of measurement noise terms in the corresponding measurement function.

Dependencies

A port is generated if you specify the measurement noise covariance as **Time-Varying** for the corresponding measurement function. The port appears when you click **Apply**.

Data Types: `single` | `double`

Enable1, Enable2, Enable3, Enable4, Enable5 — Enable correction of estimated states when measured data is available

scalar

Suppose that measured output data is not available at all time points at the port **y1** that corresponds to the first measurement function. Use a signal value other than 0 at the **Enable1** port to enable the correction of estimated states when measured data is available. Specify the port value as 0 when measured data is not available. Similarly, if measured output data is not available at all time points at the port **yi** for the i^{th} measurement function, specify the corresponding port **Enable*i*** as a value other than 0.

Dependencies

A port corresponding to a measurement function is generated if you select **Add Enable port** for that measurement function. The port appears when you click **Apply**.

Data Types: `single` | `double` | `Boolean`

Output

xhat — Estimated states

vector

Estimated states, returned as a vector of size N_s , where N_s is the number of states of the system. To access the individual states, use the Selector block.

When the **Use the current measurements to improve state estimates** parameter is selected, the block outputs the corrected state estimate $\hat{x}[k|k]$ at time step k , estimated using measured outputs until time k . If you clear this parameter, the block returns the predicted state estimate $\hat{x}[k|k-1]$ for time k , estimated using measured output until a previous time $k-1$. Clear this parameter if your filter is in a feedback loop and there is an algebraic loop in your Simulink model.

Data Types: `single` | `double`

P — State estimation error covariance

matrix

State estimation error covariance, returned as an N_s -by- N_s matrix, where N_s is the number of states of the system. To access the individual covariances, use the Selector block.

Dependencies

This port is generated if you select **Output state estimation error covariance** in the **System Model** tab, and click **Apply**.

Data Types: `single` | `double`

Parameters

System Model Tab

State Transition

Function — State transition function name

`myStateTransitionFcn` (default) | function name

The state transition function calculates the N_s -element state vector of the system at time step $k+1$, given the state vector at time step k . N_s is the number of states of the nonlinear system. You create the state transition function and specify the function name in **Function**. For example, if `vdpStateFcn.m` is the state transition function that you created and saved, specify **Function** as `vdpStateFcn`.

The inputs to the function you create depend on whether you specify the process noise as additive or nonadditive in **Process noise**.

- **Process noise** is **Additive** — The state transition function f specifies how the states evolve as a function of state values at previous time step:

$$x(k+1) = f(x(k), Us1(k), \dots, Usn(k)),$$

where $x(k)$ is the estimated state at time k , and $Us1, \dots, Usn$ are any additional input arguments required by your state transition function, such as system inputs or the sample time. To see an example of a state transition function with additive process noise, type `edit vdpStateFcn` at the command line.

- **Process noise** is **Nonadditive** — The state transition function also specifies how the states evolve as a function of the process noise w :

$$x(k+1) = f(x(k), w(k), Us1(k), \dots, Usn(k)).$$

For more information, see “State Transition and Measurement Functions” on page 3-91.

You can create f using a Simulink Function block or as a MATLAB function (`.m` file).

- You can use a MATLAB function only if f has one additional input argument $Us1$ other than x and w .

$$x(k+1) = f(x(k), w(k), Us1(k))$$

The software generates an additional input port **StateTransitionFcnInputs** to specify this argument.

- If you are using a Simulink Function block, specify x and w using Argument Inport blocks and the additional inputs $Us1, \dots, Usn$ using Inport blocks in the Simulink Function block. You do not provide $Us1, \dots, Usn$ to the Unscented Kalman Filter block.

Programmatic Use**Block Parameter:** StateTransitionFcn**Type:** character vector, string**Default:** 'myStateTransitionFcn'**Process noise — Process noise characteristics**

Additive (default) | Nonadditive

Process noise characteristics, specified as one of the following values:

- **Additive** — Process noise w is additive, and the state transition function f that you specify in **Function** has the following form:

$$x(k+1) = f(x(k), Us1(k), \dots, Usn(k)),$$

where $x(k)$ is the estimated state at time k , and $Us1, \dots, Usn$ are any additional input arguments required by your state transition function.

- **Nonadditive** — Process noise is nonadditive, and the state transition function specifies how the states evolve as a function of the state *and* process noise at the previous time step:

$$x(k+1) = f(x(k), w(k), Us1(k), \dots, Usn(k)).$$

Programmatic Use**Block Parameter:** HasAdditiveProcessNoise**Type:** character vector**Values:** 'Additive', 'Nonadditive'**Default:** 'Additive'**Covariance — Time-invariant process noise covariance**

1 (default) | scalar | vector | matrix

Time-invariant process noise covariance, specified as a scalar, vector, or matrix depending on the value of the **Process noise** parameter:

- **Process noise** is **Additive** — Specify the covariance as a scalar, an N_s -element vector, or an N_s -by- N_s matrix, where N_s is the number of states of the system. Specify a scalar if there is no cross-correlation between process noise terms and all the terms have the same variance. Specify a vector of length N_s , if there is no cross-correlation between process noise terms but all the terms have different variances.
- **Process noise** is **Nonadditive** — Specify the covariance as a W -by- W matrix, where W is the number of process noise terms.

If the process noise covariance is time-varying, select **Time-varying**. The block generates input port **Q** to specify the time-varying covariance.

Dependencies

This parameter is enabled if you do not specify the process noise as **Time-Varying**.

Programmatic Use**Block Parameter:** ProcessNoise**Type:** character vector, string**Default:** '1'**Time-varying — Time-varying process noise covariance**

'off' (default) | 'on'

If you select this parameter, the block includes an additional input port **Q** to specify the time-varying process noise covariance.

Programmatic Use

Block Parameter: HasTimeVaryingProcessNoise

Type: character vector

Values: 'off', 'on'

Default: 'off'

Initialization

Initial state — Initial state estimate

0 (default) | vector

Initial state estimate value, specified as an N_s -element vector, where N_s is the number of states in the system. Specify the initial state values based on your knowledge of the system.

Programmatic Use

Block Parameter: InitialState

Type: character vector, string

Default: '0'

Initial covariance — State estimation error covariance

1 (default) | scalar | vector | matrix

State estimation error covariance, specified as a scalar, an N_s -element vector, or an N_s -by- N_s matrix, where N_s is the number of states of the system. If you specify a scalar or vector, the software creates an N_s -by- N_s diagonal matrix with the scalar or vector elements on the diagonal.

Specify a high value for the covariance when you do not have confidence in the initial state values that you specify in **Initial state**.

Programmatic Use

Block Parameter: InitialStateCovariance

Type: character vector, string

Default: '1'

Unscented Transformation Parameters

Alpha — Spread of sigma points

1e-3 (default) | scalar value between 0 and 1

The unscented Kalman filter algorithm treats the state of the system as a random variable with a mean state value and variance. To compute the state and its statistical properties at the next time step, the algorithm first generates a set of state values distributed around the mean value by using the unscented transformation. These generated state values are called sigma points. The algorithm uses each of the sigma points as an input to the state transition and measurement functions to get a new set of transformed state points and measurements. The transformed points are used to compute the state and state estimation error covariance value at the next time step.

The spread of the sigma points around the mean state value is controlled by two parameters **Alpha** and **Kappa**. A third parameter, **Beta**, impacts the weights of the transformed points during state and measurement covariance calculations:

- **Alpha** — Determines the spread of the sigma points around the mean state value. Specify as a scalar value between 0 and 1 ($0 < \mathbf{Alpha} \leq 1$). It is usually a small positive value. The spread of

sigma points is proportional to **Alpha**. Smaller values correspond to sigma points closer to the mean state.

- **Kappa** — A second scaling parameter that is typically set to 0. Smaller values correspond to sigma points closer to the mean state. The spread is proportional to the square-root of Kappa.
- **Beta** — Incorporates prior knowledge of the distribution of the state. For Gaussian distributions, **Beta** = 2 is optimal.

If you know the distribution of state and state covariance, you can adjust these parameters to capture the transformation of higher-order moments of the distribution. The algorithm can track only a single peak in the probability distribution of the state. If there are multiple peaks in the state distribution of your system, you can adjust these parameters so that the sigma points stay around a single peak. For example, choose a small **Alpha** to generate sigma points close to the mean state value.

For more information, see “Unscented Kalman Filter Algorithm”.

Programmatic Use

Block Parameter: Alpha

Type: character vector, string

Default: '1e-3'

Beta — Characterization of state distribution

2 (default) | scalar value greater than or equal to 0

Characterization of the state distribution that is used to adjust weights of transformed sigma points, specified as a scalar value greater than or equal to 0. For Gaussian distributions, **Beta** = 2 is the optimal choice.

For more information, see the description for **Alpha**.

Programmatic Use

Block Parameter: Beta

Type: character vector, string

Default: '2'

Kappa — Spread of sigma points

0 (default) | scalar value between 0 and 3

Spread of sigma points around mean state value, specified as a scalar value between 0 and 3 ($0 \leq \mathbf{Kappa} \leq 3$). **Kappa** is typically specified as 0. Smaller values correspond to sigma points closer to the mean state. The spread is proportional to the square root of **Kappa**. For more information, see the description for **Alpha**.

Programmatic Use

Block Parameter: Kappa

Type: character vector, string

Default: '0'

Measurement

Function — Measurement function name

myMeasurementFcn (default) | function name

The measurement function calculates the N -element output measurement vector of the nonlinear system at time step k , given the state vector at time step k . You create the measurement function and

specify the function name in **Function**. For example, if `vdpMeasurementFcn.m` is the measurement function that you created and saved, specify **Function** as `vdpMeasurementFcn`.

The inputs to the function you create depend on whether you specify the measurement noise as additive or nonadditive in **Measurement noise**.

- **Measurement noise** is **Additive** — The measurement function h specifies how the measurements evolve as a function of state Values:

$$y(k) = h(x(k), Um1(k), \dots, Umn(k)),$$

where $y(k)$ and $x(k)$ are the estimated output and estimated state at time k , and $Um1, \dots, Umn$ are any optional input arguments required by your measurement function. For example, if you are using a sensor for tracking an object, an additional input could be the sensor position.

To see an example of a measurement function with additive process noise, type `edit vdpMeasurementFcn` at the command line.

- **Measurement noise** is **Nonadditive**— The measurement function also specifies how the output measurement evolves as a function of the measurement noise v :

$$y(k) = h(x(k), v(k), Um1(k), \dots, Umn(k)).$$

To see an example of a measurement function with nonadditive process noise, type `edit vdpMeasurementNonAdditiveNoiseFcn`.

For more information, see “State Transition and Measurement Functions” on page 3-91.

You can create h using a Simulink Function block or as a MATLAB function (.m file).

- You can use a MATLAB function only if h has one additional input argument $Um1$ other than x and v .

$$y[k] = h(x[k], v[k], Um1(k))$$

The software generates an additional input port **MeasurementFcnInput** to specify this argument.

- If you are using a Simulink Function block, specify x and v using Argument Inport blocks and the additional inputs $Um1, \dots, Umn$ using Inport blocks in the Simulink Function block. You do not provide $Um1, \dots, Umn$ to the Unscented Kalman Filter block.

If you have multiple sensors in your system, you can specify multiple measurement functions. You can specify up to five measurement functions using the **Add Measurement** button. To remove measurement functions, use **Remove Measurement**.

Programmatic Use

Block Parameter: MeasurementFcn1, MeasurementFcn2, MeasurementFcn3, MeasurementFcn4, MeasurementFcn5

Type: character vector, string

Default: 'myMeasurementFcn'

Measurement noise — Measurement noise characteristics

Additive (default) | Nonadditive

Measurement noise characteristics, specified as one of the following values:

- **Additive** — Measurement noise v is additive, and the measurement function h that you specify in **Function** has the following form:

$$y(k) = h(x(k), U_{m1}(k), \dots, U_{mn}(k)),$$

where $y(k)$ and $x(k)$ are the estimated output and estimated state at time k , and U_{m1}, \dots, U_{mn} are any optional input arguments required by your measurement function.

- **Nonadditive** — Measurement noise is nonadditive, and the measurement function specifies how the output measurement evolves as a function of the state *and* measurement noise:

$$y(k) = h(x(k), v(k), U_{m1}(k), \dots, U_{mn}(k)).$$

Programmatic Use

Block Parameter: HasAdditiveMeasurementNoise1, HasAdditiveMeasurementNoise2, HasAdditiveMeasurementNoise3, HasAdditiveMeasurementNoise4, HasAdditiveMeasurementNoise5

Type: character vector

Values: 'Additive', 'Nonadditive'

Default: 'Additive'

Has measurement wrapping — Enable measurement wrapping

off (default) | on

Select this parameter to enable measurement wrapping to estimate states when you have circular measurements that are independent of your model states. If you select this parameter, then the measurement function you specify must include the following two outputs:

- 1 The measurement, specified as a N -element output measurement vector of the nonlinear system at time step k , given the state vector at time step k . N is the number of measurements of the system.
- 2 The measurement wrapping bounds, specified as an N -by-2 matrix where, the first column provides the minimum measurement bound and the second column provides the maximum measurement bound.

Enabling the **Has measurement wrapping** check box wraps the measurement residuals in a defined bound, which helps to prevent the filter from divergence due to incorrect measurement residual values. For an example, see “State Estimation with Wrapped Measurements Using Extended Kalman Filter”.

Programmatic Use

Block Parameter: HasMeasurementWrapping1, HasMeasurementWrapping2, HasMeasurementWrapping3, HasMeasurementWrapping4, HasMeasurementWrapping5

Type: character vector

Values: 'off', 'on'

Default: 'off'

Covariance — Time-invariant measurement noise covariance

1 (default) | matrix

Time-invariant measurement noise covariance, specified as a matrix. The size of the matrix depends on the value of the **Measurement noise** parameter:

- **Measurement noise** is Additive — Specify the covariance as an N -by- N matrix, where N is the number of measurements of the system.

- **Measurement noise** is Nonadditive — Specify the covariance as a V -by- V matrix, where V is the number of measurement noise terms.

If the measurement noise covariance is time-varying, select **Time-varying**. The block generates input port **R i** to specify the time-varying covariance for the i^{th} measurement function.

Dependencies

This parameter is enabled if you do not specify the process noise as **Time-Varying**.

Programmatic Use

Block Parameter: MeasurementNoise1, MeasurementNoise2, MeasurementNoise3, MeasurementNoise4, MeasurementNoise5

Type: character vector, string

Default: '1'

Time-varying — Time-varying measurement noise covariance

off (default) | on

If you select this parameter for the measurement noise covariance of the first measurement function, the block includes an additional input port **R1**. You specify the time-varying measurement noise covariance in **R1**. Similarly, if you select **Time-varying** for the i^{th} measurement function, the block includes an additional input port **R i** to specify the time-varying measurement noise covariance for that function.

Programmatic Use

Block Parameter: HasTimeVaryingMeasurementNoise1, HasTimeVaryingMeasurementNoise2, HasTimeVaryingMeasurementNoise3, HasTimeVaryingMeasurementNoise4, HasTimeVaryingMeasurementNoise5

Type: character vector

Values: 'off', 'on'

Default: 'off'

Add Enable Port — Enable correction of estimated states only when measured data is available

off (default) | on

Suppose that measured output data is not available at all time points at the port **y1** that corresponds to the first measurement function. Select **Add Enable port** to generate an input port **Enable1**. Use a signal at this port to enable the correction of estimated states only when measured data is available. Similarly, if measured output data is not available at all time points at the port **y i** for the i^{th} measurement function, select the corresponding **Add Enable port**.

Programmatic Use

Block Parameter: HasMeasurementEnablePort1, HasMeasurementEnablePort2, HasMeasurementEnablePort3, HasMeasurementEnablePort4, HasMeasurementEnablePort5

Type: character vector

Values: 'off', 'on'

Default: 'off'

Settings

Use the current measurements to improve state estimates — Choose between corrected or predicted state estimate

on (default) | off

When this parameter is selected, the block outputs the corrected state estimate $\hat{x}[k|k]$ at time step k , estimated using measured outputs until time k . If you clear this parameter, the block returns the predicted state estimate $\hat{x}[k|k-1]$ for time k , estimated using measured output until a previous time $k-1$. Clear this parameter if your filter is in a feedback loop and there is an algebraic loop in your Simulink model.

Programmatic Use

Block Parameter: UseCurrentEstimator

Type: character vector

Values: 'off', 'on'

Default: 'on'

Output state estimation error covariance – Output state estimation error covariance

off (default) | on

If you select this parameter, a state estimation error covariance output port **P** is generated in the block.

Programmatic Use

Block Parameter: OutputStateCovariance

Type: character vector

Values: 'off', 'on'

Default: 'off'

Data type – Data type for block parameters

double (default) | single

Use this parameter to specify the data type for all block parameters.

Programmatic Use

Block Parameter: DataType

Type: character vector

Values: 'single', 'double'

Default: 'double'

Sample time – Block sample time

1 (default) | positive scalar

Block sample time, specified as a positive scalar. If the sample times of your state transition and measurement functions are different, select **Enable multirate operation** in the **Multirate** tab, and specify the sample times in the **Multirate** tab instead.

Dependencies

This parameter is available if in the **Multirate** tab, the **Enable multirate operation** parameter is off.

Programmatic Use

Block Parameter: SampleTime

Type: character vector, string

Default: '1'

Multirate Tab

Enable multirate operation — Enable specification of different sample times for state transition and measurement functions

off (default) | on

Select this parameter if the sample times of the state transition and measurement functions are different. You specify the sample times in the **Multirate** tab, in **Sample time**.

Programmatic Use

Block Parameter: EnableMultirate

Type: character vector

Values: 'off', 'on'

Default: 'off'

Sample times — State transition and measurement function sample times

positive scalar

If the sample times for state transition and measurement functions are different, specify **Sample time**. Specify the sample times for the measurement functions as positive integer multiples of the state transition sample time. The sample times you specify correspond to the following input ports:

- Ports corresponding to state transition function — Additional input to state transition function **StateTransitionFcnInputs** and time-varying process noise covariance **Q**. The sample times of these ports must always equal the state transition function sample time, but can differ from the sample time of the measurement functions.
- Ports corresponding to i^{th} measurement function — Measured output **y i** , additional input to measurement function **MeasurementFcn i Inputs**, enable signal at port **Enable i** , and time-varying measurement noise covariance **R i** . The sample times of these ports for the same measurement function must always be the same, but can differ from the sample time for the state transition function and other measurement functions.

Dependencies

This parameter is available if in the **Multirate** tab, the **Enable multirate operation** parameter is on.

Programmatic Use

Block Parameter: StateTransitionFcnSampleTime, MeasurementFcn1SampleTime1, MeasurementFcn1SampleTime2, MeasurementFcn1SampleTime3, MeasurementFcn1SampleTime4, MeasurementFcn1SampleTime5

Type: character vector, string

Default: '1'

More About

State Transition and Measurement Functions

The algorithm computes the state estimates \hat{x} of the nonlinear system using state transition and measurement functions specified by you. You can specify up to five measurement functions, each corresponding to a sensor in the system. The software lets you specify the noise in these functions as additive or nonadditive.

- **Additive Noise Terms** — The state transition and measurements equations have the following form:

$$x[k + 1] = f(x[k], u_s[k]) + w[k]$$

$$y[k] = h(x[k], u_m[k]) + v[k]$$

Here f is a nonlinear state transition function that describes the evolution of states x from one time step to the next. The nonlinear measurement function h relates x to the measurements y at time step k . w and v are the zero-mean, uncorrelated process and measurement noises, respectively. These functions can also have additional optional input arguments that are denoted by u_s and u_m in the equations. For example, the additional arguments could be time step k or the inputs u to the nonlinear system. There can be multiple such arguments.

Note that the noise terms in both equations are additive. That is, $x(k+1)$ is linearly related to the process noise $w(k)$, and $y(k)$ is linearly related to the measurement noise $v(k)$. For additive noise terms, you do not need to specify the noise terms in the state transition and measurement functions. The software adds the terms to the output of the functions.

- **Nonadditive Noise Terms** — The software also supports more complex state transition and measurement functions where the state $x[k]$ and measurement $y[k]$ are nonlinear functions of the process noise and measurement noise, respectively. When the noise terms are nonadditive, the state transition and measurements equation have the following form:

$$x[k + 1] = f(x[k], w[k], u_s[k])$$

$$y[k] = h(x[k], v[k], u_m[k])$$

Version History

Introduced in R2017a

Numerical Changes

Behavior changed in R2020b

Starting in R2020b, numerical improvements in the Unscented Kalman Filter algorithm might produce results that are different from the results you obtained in previous versions.

Extended Capabilities

C/C++ Code Generation

Generate C and C++ code using Simulink® Coder™.

The state transition and measurement functions that you specify must use only the MATLAB commands and Simulink blocks that support code generation. For a list of blocks that support code generation, see “Simulink Built-In Blocks That Support Code Generation” (Simulink Coder). For a list of commands that support code generation, see “Functions and Objects Supported for C/C++ Code Generation” (MATLAB Coder).

Generated code uses an algorithm that is different from the algorithm that the Unscented Kalman Filter block itself uses. You might see some numerical differences in the results obtained using the two methods.

See Also

Blocks

Kalman Filter | Extended Kalman Filter | Particle Filter

Functions

`extendedKalmanFilter` | `unscentedKalmanFilter` | `kalman` | `kalmd` | `particleFilter`

Topics

“Extended and Unscented Kalman Filter Algorithms for Online State Estimation”

“Validate Online State Estimation in Simulink”

“Troubleshoot Online State Estimation”

External Websites

Understanding Kalman Filters: Nonlinear State Estimators — MATLAB Video Series

Varying Lowpass Filter

Butterworth filter with varying coefficients

Library: Control System Toolbox / Linear Parameter Varying

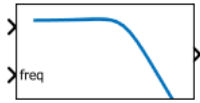

Varying Lowpass Filter

Description

The block implements an analog N^{th} -order Butterworth filter with unit DC gain and varying cutoff frequency.

Use this block and the other blocks in the Linear Parameter Varying library to implement common control elements with variable parameters or coefficients. For more information, see “Model Gain-Scheduled Control Systems in Simulink”.

Ports

Input

u — Filter input

scalar

Lowpass filter input signal.

freq — Cutoff frequency

scalar

Filter cutoff frequency, specified in rad/s.

Output

y — Filter output

scalar

Lowpass filter output signal.

Parameters

Filter order — Lowpass filter order

1 (default) | positive integer

Lowpass filter order, specified as a positive integer.

Version History

Introduced in R2017b

Extended Capabilities

C/C++ Code Generation

Generate C and C++ code using Simulink® Coder™.

See Also

Discrete Varying Lowpass

Topics

“Model Gain-Scheduled Control Systems in Simulink”

Varying Notch Filter

Notch filter with varying coefficients

Library: Control System Toolbox / Linear Parameter Varying

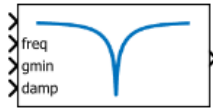

Varying Notch Filter

Description

The block implements a continuous-time notch filter with varying coefficients. The instantaneous transfer function of the filter is given by:

$$N(s) = \frac{s^2 + 2 * gmin * damp * freq * s + freq^2}{s^2 + 2 * damp * freq * s + freq^2},$$

where $gmin$, $damp$, and $freq$ are the values supplied at the corresponding input ports. These parameters control the notch depth and frequency as shown in the following illustration. The damping ratio $damp$ controls the notch width Δ ; larger $damp$ means larger Δ .

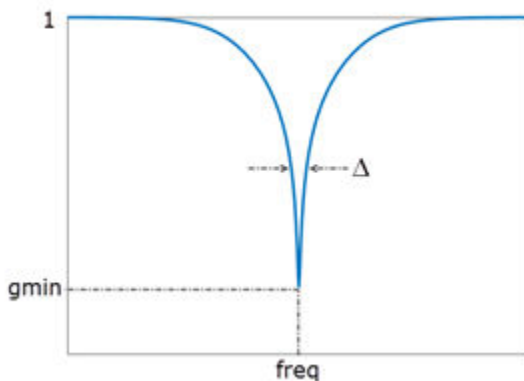

Use this block and the other blocks in the Linear Parameter Varying library to implement common control elements with variable parameters or coefficients. For more information, see “Model Gain-Scheduled Control Systems in Simulink”.

Ports

Input

u — Filter input

scalar

Notch filter input signal

freq — Notch frequency

scalar

Value of the notch frequency, specified in rad/s.

gmin — Gain at notch frequency

scalar

Value of the gain at notch frequency, in absolute units. This value controls the notch depth. The notch filter has unit gain at low and high frequency. The gain is lowest at the notch frequency, the value at the **freq** port.

damp — Damping ratio of the filter poles

scalar

Value of the damping ratio, specified as a positive scalar value. The damping ratio controls the notch width; the closer to 0, the steeper the notch.

Output**y — Filter output**

scalar

Notch filter output signal.

Version History

Introduced in R2017b

Extended Capabilities

C/C++ Code Generation

Generate C and C++ code using Simulink® Coder™.

See Also

Discrete Varying Notch

Topics

“Model Gain-Scheduled Control Systems in Simulink”

Varying Observer Form

Observer-form state-space model with varying matrix values

Library: Control System Toolbox / Linear Parameter Varying

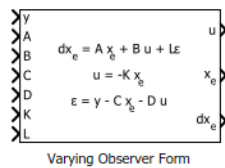

Description

Use this block to implement a continuous-time varying state-space model in observer form. The system matrices A , B , C , and D describe the plant dynamics, and the matrices K and L specify the state-feedback and state-observer gains, respectively. Feed the instantaneous values of these matrices to the corresponding input ports. The observer form is given by:

$$\begin{aligned} dx_e &= Ax_e + Bu + L\varepsilon \\ u &= -Kx_e \\ \varepsilon &= y - Cx_e - Du, \end{aligned}$$

where u is the plant input, y is the plant output, x_e is the estimated state, and ε is the innovation, the difference between the predicted and measured plant output. The observer form works well for gain scheduling of state-space controllers. In particular, the state x_e tracks the plant state, and all controllers are expressed with the same state coordinates.

Use this block and the other blocks in the Linear Parameter Varying library to implement common control elements with variable parameters or coefficients. For more information, see “Model Gain-Scheduled Control Systems in Simulink”.

Ports

Input

y — Measurement signal

scalar | vector

Measured plant output signal.

A — Plant state matrix

matrix

Plant state matrix of dimensions N_x -by- N_x , where N_x is the number of plant states.

B — Plant input matrix

matrix

Plant input matrix of dimensions N_x -by- N_u , where N_u is the number of plant inputs.

C — Plant output matrix

matrix

Plant output matrix N_y -by- N_x , where N_y is the number of plant outputs.

D — Plant feedforward matrix

matrix

Plant feedforward matrix of dimensions N_y -by- N_u .

K — State-feedback matrix

matrix

State-feedback matrix of dimensions N_u -by- N_x .

L — State-observer matrix

matrix

State-observer matrix of dimensions N_x -by- N_y .

Output

u — Control signal

scalar | vector

Control signal (plant input).

\mathbf{x}_e — Estimated plant state vector

vector

Vector of estimated plant states.

Dependencies

To enable this port, select the **Output states** parameter.

\mathbf{dx}_e — Estimated state derivatives

vector

Derivatives of the corresponding estimated states in \mathbf{x}_e .

Dependencies

To enable this port, select the **Output state updates** parameter.

Parameters

Initial conditions — System initial conditions

0 (default) | scalar | vector

Initial state values, specified as a scalar or a vector whose length is the number of plant states.

State names (e.g., 'position') — Plant state names

' ' (default) | character vector | cell array

To identify plant states, specify state names as a:

- character vector, for a one-state plant.

- Cell array of character vectors, for a multistate plant.

Output states — Provide state output

on (default) | off

Select to enable the estimated states output port, \mathbf{x}_e .

Output state derivatives — Provide state derivatives

on (default) | off

Select to enable the estimated state derivatives output port, \mathbf{dx}_e .

Version History

Introduced in R2017b

Extended Capabilities

C/C++ Code Generation

Generate C and C++ code using Simulink® Coder™.

See Also

Discrete Varying Observer Form | Varying State Space

Topics

“Model Gain-Scheduled Control Systems in Simulink”

Varying State Space

State-space model with varying matrix values

Library: Control System Toolbox / Linear Parameter Varying

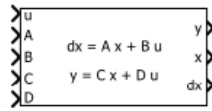

Varying State Space

Description

Use this block to implement a continuous-time state-space model with varying matrices. Feed the instantaneous values of the state matrix A , input matrix B , output matrix C , and feedforward matrix D to the corresponding input ports. The system response is given by:

$$\begin{aligned} dx &= Ax + Bu \\ y &= Cx + Du, \end{aligned}$$

where u is the system input, y is the system output, and x and dx are the state vector and state derivatives, respectively.

Use this block and the other blocks in the Linear Parameter Varying library to implement common control elements with variable parameters or coefficients. For more information, see “Model Gain-Scheduled Control Systems in Simulink”.

Ports

Input

u — System input

scalar | vector

System input signal.

A — State matrix

matrix

State matrix of dimensions N_x -by- N_x , where N_x is the number of system states.

B — Input matrix

matrix

Input matrix of dimensions N_x -by- N_u , where N_u is the number of system inputs.

C — Output matrix

matrix

Output matrix N_y -by- N_x , where N_y is the number of system outputs.

D — Feedforward matrix

matrix

Feedforward matrix of dimensions N_y -by- N_u .

Output

y — System output

scalar | vector

System output signal.

x — Current state vector

vector

Current state values.

Dependencies

To enable this port, select the **Output states** parameter.

dx — State derivatives

vector

Current derivatives of the corresponding states in **x**.

Dependencies

To enable this port, select the **Output state derivatives** parameter.

Parameters

Initial conditions — System initial conditions

0 (default) | scalar | vector

Initial state values, specified as a scalar or a vector whose length is the number of system states.

State names — System state names

' ' (default) | character vector | cell array

To identify system states, specify state names as a:

- character vector, for a one-state plant.
- Cell array of character vectors, for a multistate plant.

Output states — Provide state output

on (default) | off

Select to enable the state values output port, **x**.

Output state derivatives — Provide state derivatives

on (default) | off

Select to enable the state derivatives output port, **dx**.

Version History

Introduced in R2017b

Extended Capabilities

C/C++ Code Generation

Generate C and C++ code using Simulink® Coder™.

See Also

Discrete Varying State Space

Topics

“Model Gain-Scheduled Control Systems in Simulink”

Varying Transfer Function

Transfer function with varying coefficients

Library: Control System Toolbox / Linear Parameter Varying

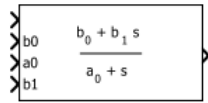

Varying Transfer Function

Description

This block implements a continuous-time transfer function with varying coefficients. The instantaneous transfer function is given by:

$$H(s) = \frac{b_0 + b_1s + \dots b_Ns^N}{a_0 + a_1s + \dots a_{N-1}s^{N-1} + s^N}$$

where N is number of poles, specified with the **Transfer function order** parameter. Feed the values of the coefficients a_0, a_1, \dots, a_{N-1} and b_0, b_1, \dots, b_N to the corresponding block input ports.

Use this block and the other blocks in the Linear Parameter Varying library to implement common control elements with variable parameters or coefficients. For more information, see “Model Gain-Scheduled Control Systems in Simulink”.

Ports

Input

u — Transfer function input

scalar

Transfer function input signal.

b0, b1, ... — Numerator coefficients

scalar

Transfer function numerator coefficients. The number of coefficient ports is determined by the **Transfer function order** parameter.

a0, a1, ... — Denominator coefficients

scalar

Transfer function denominator coefficients. The number of coefficient ports is determined by the **Transfer function order** parameter. The coefficient on the highest-order term is fixed to 1.

Output

y — Transfer function output

scalar

Transfer function output signal.

Parameters

Transfer function order — Number of poles

1 (default) | positive integer

Transfer function (number of poles), specified as a positive integer. This parameter determines the number of coefficient input ports on the block.

Version History

Introduced in R2017b

Extended Capabilities

C/C++ Code Generation

Generate C and C++ code using Simulink® Coder™.

See Also

Discrete Varying Transfer Function

Topics

“Model Gain-Scheduled Control Systems in Simulink”

